

UCHC-9 Rev. 05/07

Previous Rev. 01/07

**UNIVERSITY OF CONNECTICUT HEALTH CENTER**  
**FACILITY CONTRACTS & LEASES**  
**263 Farmington Avenue, MC4039**  
**Farmington, CT 06032**

<b>Bid Number</b> <b>4-0015</b>
<b>Bid Due Date:</b> <b>January 30, 2009</b>

**Jennifer K. Kelley**  
*Senior Purchasing Officer*

**860-679-1988**  
*Telephone Number*

**Bid: 4-0015**

**Addendum Number: 4**

**Title: CT Scanner Replacement**

**For: The University of Connecticut Health Center**

**Bidders Note:**

**Due to the possibility of inclement weather tomorrow, January 28, 2009, the Due Date for this bid is hereby extended to Friday, January 30, 2009 at 2:30 PM.**

All other terms & conditions remain unchanged

End of Addendum

This Addendum must be *Signed & Returned* with your bid.

\_\_\_\_\_

Authorized Signature of Bidder

\_\_\_\_\_

Company Name

Approved \_\_\_\_\_

**Jennifer K. Kelley**  
**Purchasing Services Officer**  
 (Original signature on file in Facility Contract & Leases)

Dated Issued: January 27, 2009

UNIVERSITY OF CONNECTICUT HEALTH CENTER  
FACILITY CONTRACTS & LEASES  
263 Farmington Avenue, MC4039  
Farmington, CT 06032

Bid Number <b>4-0015</b>
Bid Due Date: <b>January 28, 2009</b>

Jennifer K. Kelley  
Senior Purchasing Officer

860-679-1988  
Telephone Number

**Bid: 4-0015**  
**Addendum Number: 3**

**Title: CT Scanner Replacement**  
**For: The University of Connecticut Health Center**

**Bidders Note:**

**Please incorporate the following information into your bid specification package.**

Description: Mechanical Drawings:

1. On drawing M-2, MECHANICAL SCHEDULES & DETAILS, dated December 12, 2008, **AIR HANDLING UNIT SCHEDULE** the correct Model No. for AC-2 is **BU 060E**.
2. On drawing M-2, MECHANICAL SCHEDULES & DETAILS, dated December 12, 2008, **AIR COOLED CONDENSING UNIT SCHEDULE** the correct Model No. for CU-2 is **PF 067A**

Q: Addendum 1 SKM-04 shows reusing one inch chilled water supply and return from new CT Scan equipment to CH-1. Addendum 1 SKM-03 calls for new one inch supply and return to the new process chiller. Are we reusing the existing line?

**A: The existing 1" lines from the indoor unit in the floor are to be reused. New flexible connectors are to be installed at each end.**

Q: Please confirm who is supplying AC-2 and CU-2.

**A: These units are by the Contractor.**

**Due date remains January 28, 2009 at 2:30 PM.**

All other terms & conditions remain unchanged

End of Addendum

This Addendum must be <i>Signed &amp; Returned</i> with your bid.	
_____	_____
Authorized Signature of Bidder	Company Name

Approved \_\_\_\_\_  
Jennifer K. Kelley  
Purchasing Services Officer  
(Original signature on file in Facility Contract & Leases)

UNIVERSITY OF CONNECTICUT HEALTH CENTER  
FACILITY CONTRACTS & LEASES  
263 Farmington Avenue, MC4039  
Farmington, CT 06032

Bid Number <b>4-0015</b>
Bid Due Date: <b>January 28, 2009</b>

Jennifer K. Kelley  
Senior Purchasing Officer

860-679-1988  
Telephone Number

**Bid: 4-0015**

**Addendum Number: 2**

**Title: CT Scanner Replacement**

**For: The University of Connecticut Health Center**

**Bidders Note:**

Please incorporate the information found on the following pages into your bid specification package.

Due date remains January 28, 2009 at 2:30 PM.

All other terms & conditions remain unchanged

End of Addendum

This Addendum must be *Signed & Returned* with your bid.

\_\_\_\_\_  
Authorized Signature of Bidder

\_\_\_\_\_  
Company Name

Approved \_\_\_\_\_  
Jennifer K. Kelley  
Purchasing Services Officer  
(Original signature on file in Facility Contract & Leases)

Dated Issued: January 16, 2009

**UCONN HEALTH CENTER  
REPLACEMENT CT SCANNER  
PROJECT NUMBER 08-050  
FARMINGTON, CONNECTICUT**

The following changes to the Drawings and Project Manual shall become a part of the Drawings, Bidding Requirements, and Contract Documents; superseding previously issued Drawings, Bidding Requirements and Contract Documents, to the extent modified by this Addendum No. 2.

**REVISED MEP DRAWINGS**

Revise various plumbing, fire protection, mechanical, and electrical Drawings as indicated on attached Addendum No. 2 prepared by Consulting Engineering Services, Inc.

**CHANGES TO PROJECT MANUAL**

**NEW SPECIFICATION SECTIONS**

The following new specification sections unless otherwise indicated, attached to this Addendum, are hereby made part of the Contract Documents.

<u>Section No.</u>	<u>Title</u>
01030 –	Alternates

**REVISED SPECIFICATION SECTIONS**

The following revised specification sections unless otherwise indicated, attached to this Addendum, are hereby made part of the Contract Documents.

<u>Section No.</u>	<u>Title</u>
Attachment A –	Table of Contents
--- –	Bid Form

**END OF ADDENDUM NO. 2**



## Addendum

Addendum Number: 2  
Addendum Date: January 16, 2008  
Written To: Vikas Nagardeoleker - Fletcher-Thompson Inc.  
Project Name: UCHC Replacement CT Scanner  
UCHC Project No.: 08-050  
CES Project Number: 28145.00  
Written By: Loren Grabinsky

The work shall be carried out in accordance with the following supplemental instructions and in accordance with the Contract Documents.

Description:

Electrical Drawings:

1. **PROVIDE** Panel 'CT' per the attached panel schedule and per Specification Section 16050.

End of Addendum No. 2

Attachments: Panel 'CT' Schedule

P:\28145.00\CA\Addendum\Addendum#2.doc

<b>PANEL:</b>			<b>CT-1</b>	<b>MAIN:</b>	100A MCB			<b>NOTES:</b>				
<b>LOCATION:</b>			Reading LM078	<b>V &amp; PH:</b>	480Y/277V, 3PH, 4W							
<b>MOUNTING:</b>			Recessed	<b>A.I.C.</b>	Per Specifications							
<b>BREAKER</b>			<b>PHASE LOAD - KVA</b>					<b>BREAKER</b>				
NO.	A	P	DESCRIPTION	LOAD KVA	A	B	C	LOAD KVA	DESCRIPTION	A	P	NO.
1	/	/		1.20	12.10			10.90		/	/	2
3	20	3	AC-2	1.20		12.10		10.90	CU-2	50	3	4
5	/	/		1.20			12.10	10.90		/	/	6
7	20	1	Spare		0.00				Spare	20	1	8
9	20	1	Spare			0.00			Spare	20	1	10
11	20	1	Spare				0.00		Spare	20	1	12
13	20	1	Spare		0.00				Spare	20	1	14
15	20	1	Spare			0.00			Spare	20	1	16
17	20	1	Spare				0.00		Spare	20	1	18
19	20	1	Spare		0.00				Spare	20	1	20
21	20	1	Space			0.00			Space	20	1	22
23	20	1	Space				0.00		Space	20	1	24
<b>TOTAL LOAD PER PHASE:</b>					12.10	12.10	12.10					
<b>TOTAL LOAD ON PANEL:</b>					36.30		KVA					

## **SECTION 01030 ALTERNATES**

### **PART 1 - GENERAL**

#### 1.01 RELATED DOCUMENTS

- A. Drawings and general provisions of Contract, including General and Supplementary Conditions and other Division-1 Specification Sections, apply to this Section.

#### 1.02 SUMMARY

- A. This Section specifies administrative and procedural requirements for Alternates.
- B. Definition: An Alternate is an amount proposed by Bidders and stated on the Bid Form for certain construction activities defined in the Bidding Requirements that may be added to or deducted from Base Bid amount if the Owner decides to accept a corresponding change in either the amount of construction to be completed, or in the products, materials, equipment, systems or installation methods described in Contract Documents.
- C. Coordination: Coordinate related Work and modify or adjust adjacent Work as necessary to ensure that Work affected by each accepted Alternate is complete and fully integrated into the project.
- D. Notification: Immediately following the award of the Contract, prepare and distribute to each party involved, notification of the status of each Alternate. Indicate whether Alternates have been accepted, rejected or deferred for consideration at a later date. Include a complete description of negotiated modifications to Alternates.
- E. Schedule: A "Schedule of Alternates" is included at the end of this Section. Specification Sections referenced in the Schedule contain requirements for materials and methods necessary to achieve the Work described under each Alternate.

Include as part of each Alternate, miscellaneous devices, accessory objects and similar items incidental to or required for a complete installation whether or not mentioned as part of the Alternate.

### **PART 2 - PRODUCTS (Not Applicable)**

### **PART 3 - EXECUTION**

#### 3.01 SCHEDULE OF ALTERNATES

- A. This Section specifies administrative and procedural requirements for Alternates.
- B. ADD Alternate No. 1 – Provide cost associated with all work related to fit-up of Equipment Room LM 079B, including but not limited to the following:
  - 1. Demolition of ceilings, including ceiling pads and grid.
  - 2. Relocation of light fixtures, sprinkler heads, HVAC diffusers, smoke detectors, speakers, etc.
  - 3. Demolition of electrical equipment including duplex receptacles, wiring, etc.
  - 4. Installation of new sheetrock walls, door frame, doors, hardware.
  - 5. Installation of new ceiling including ceiling tile and grid.

6. Installation of new UPS equipment including rigging, interconnection conduit and wiring per Siemens drawings, EPO switch, new AC-2 and CU-2, new Panel 'CT', including all mechanical piping and supports, core drilling, ceiling work for installation of new piping and electrical wiring, conduit and wiring, fire-stopping, access doors, junction boxes, etc.
7. Testing and balancing.

END OF SECTION



ATTACHMENT - A

UNIVERSITY OF CONNECTICUT  
HEALTH CENTER  
REPLACEMENT CT SCANNER

**TABLE OF CONTENTS**

I. **PROJECT MANUAL**

**Division 0 - General Conditions**

Table of Contents	4
List of Drawings	2
Instructions to Bidders AIA A 701	6
Contractor's Qualification Statement AIA A-305	4
Bid Form	8
Bid Bond	2
UCONN Performance Bond	1
UCONN Payment Bond	1
Standard Form of Agreement Between Owner and Contractor, AIA A-101	14
General Conditions, AIA A-201	106
Application for Payment, AIA G-702/703	4
List of Subcontractors, UCHC FORM 550.13A	2
Background Information Sheet	1

**Division 1 - General Requirements**

01015	General Project Requirements	10
01018	Special Project Procedures	4
01020	Construction Area Environmental Control - Class 3, 4	6
<u>01030</u>	<u>Alternates</u>	<u>2</u>
01045	Cutting and Patching	4
01300	Submittals	6
01631	Product Substitutions	4
01700	Project Closeout	4

01710	Project Cleaning	4
01740	Warranties and Bonds	2

**Division 2 - Site Work**

02070	Selective Demolition	8
-------	----------------------	---

**Division 3 - Concrete**

Not Used

**Division 4 - Masonry**

Not Used

**Division 5 - Metals**

Not Used

**Division 6 - Wood and Plastics**

06100	Rough Carpentry	6
06200	Finish Carpentry	4
06400	Architectural Millwork	10

**Division 7 - Thermal and Moisture Protection**

07720	<u>Roof Accessories</u>	4
07841	Through-Penetration Firestop System	10
07920	Joint Sealants	4

**Division 8 - Doors and Windows**

08111	Steel Frames	4
08210	Wood Doors	6
08710	Finish Hardware	8

**Division 9 - Finishes**

09110	Non-Load-Bearing Wall Framing	4
09250	Gypsum Board	6
09510	Acoustical Ceilings	4
09653	Resilient Wall Base and Accessories	6
09900	Paints and Coatings	12

**Division 10 - Specialties**

Not Used

**Division 11 - Equipment**

Not Used

**Division 12 - Furnishings**

Not Used

**Division 13 - Special Construction**

Not Used

**Division 14 - Conveying Systems**

Not Used

**Division 15 - Mechanical**

15010	General Conditions for Mechanical Trades	--
15050	Basic Mechanical Materials and Design Parameters	--
15260	Mechanical Insulation	--
15300	Fire Protection Systems	--
15400	Plumbing Systems	--
15410	Plumbing Piping	--
15420	Valves	--
15421	Backflow Prevention Devices	--
15453	Plumbing Pumps	--
15500	HVAC Systems	--
15530	Refrigerant Piping	--
15680	Chillers and Accessories	--
15751	Packaged Heat Transfer Equipment	--
15850	Air Handling	--
15890	Ductwork and Ductwork Accessories	--
15970	Control Systems Equipment	--
15990	Testing, Adjusting, and Balancing	--
15995	Air Flow Testing	--

**Division 16 - Electrical**

16010	General Conditions for Electrical Trades	--
16050	Basic Electrical Materials and Methods	--
16504	Occupancy Sensors	--
16510	Interior Lighting	--
16615	Emergency Lighting	--
16725	Fire Alarm System	--
16740	Telecommunications Outlets	--

END OF TABLE OF CONTENTS

THIS PAGE INTENTIONALLY LEFT BLANK

**PROJECT NAME:** REPLACEMENT CT SCANNER

**PROJECT NUMBER:** 08-050

**PROPOSAL OF:**  
BIDDER'S NAME

BIDDER'S ADDRESS

**DATE:** \_\_\_\_\_

1. In accordance with Connecticut General Statutes Sections 10a-109a through 10a-109y and pursuant to, and in compliance with your Invitation to Bid, the Notice and Instructions to Bidders, the Form of Contract, including the conditions thereto, the form of required bond, I (we) propose to furnish the labor and/or materials installed as required for the project named and numbered on the BID FORM of this proposal to the extent of the Proposal submitted herein, furnishing all necessary equipment, machinery, tools, labor and other means of construction, and all materials specified in the manner and at the time prescribed strictly in accordance with the provisions of the Contract including specifications and/or drawings together with all addenda issued and received prior to the scheduled closing time for the receipt of the bids, and in conformity with requirements of the University of Connecticut and any laws or departmental regulations of the State of Connecticut or of the United States which may affect the same, for and in consideration of the price(s) stated on the said BID FORM, hereof.
  
2. The Lump Sum Base Bid by me (us) on the BID FORM includes all work indicated on the drawings and/or described in the specifications, except:
  - A. Work covered by Alternates as may be listed on the BID FORM.
  - B. Contingent work covered by Unit Prices as may be listed on the BID FORM.
  - C. Work covered by Options as may be listed on the BID FORM.
  
3. This proposal is submitted subject to and in compliance with the foregoing and following conditions and/or information.
  - A. AWARD: All proposals shall be subject to the provisions and requirements of the Bid Documents and for purpose of award, consideration shall be given only to proposals submitted by qualified and responsible bidders.
  - B. COMMENCEMENT AND COMPLETION OF WORK: Contractor shall commence and complete the work in accordance with the requirements of the Contract Documents.

C. If the Contractor fails to complete the work within the time required by the Contract Documents, the University shall have the right to assess liquidated damages as provided in Paragraph 9.11 of the General Conditions.

D. AVAILABILITY OF FUNDS:

The funding for this project is contingent upon the continued availability of funds. Funds will be released based on project phases.

E. CONTRACTORS INSURANCE REQUIRED:

1. The limits of liability and coverages shall be those set forth in Article 11 of the General Conditions.

F. STATEMENT OF BIDDERS' QUALIFICATIONS AND INTENTION OF OBJECTIVE CRITERIA:

1. Each Project estimated to be \$500,000 and greater, Bidders shall be required to complete and submit qualification forms to obtain "Pre-qualified Status" prior to submission of Bids. Contractors not obtaining "Pre-qualified Status" shall not be allowed to submit a Bid on said projects.

2. For Projects estimated to be less than \$500,000 the Bidder shall complete and submit with this BID FORM the Contractor's Qualification Statement (AIA Form A-305) in support of its Qualifications to perform the Work of this project, and to demonstrate its compliance with the University's Objective Criteria regarding Qualifications.

G. FEDERAL & STATE WAGE DETERMINATIONS AND PRICING CONSIDERATION:

1 Each contractor who is awarded a contract on or after October 1, 2002 shall be subject to provisions of the Connecticut General Statutes, Section 31-53 as amended by Public Act 02-69, "An Act Concerning Annual Adjustments to Prevailing Wages".

2 In determining bid price, consideration should be given to Section 31-53 of the General Statutes of Connecticut as amended by Public Act 02-69, "An Act Concerning Annual Adjustments to Prevailing Wages". Such prevailing wage adjustment will not be considered a basis for an annual contract adjustment.

3 The State of Connecticut Labor Department Wage Schedule where required, shall be provided with these documents, typically as part of the University of Connecticut Health Center Purchasing Department issued documents, or will be incorporated in the Contract Documents as an Addendum. At the time of bidding, the bidder agrees to accept the current prevailing wage scale, as well as any annual adjustment to the prevailing wage scale, as provided by the Connecticut Department of Labor. Wage Rates will be posted each July 1st on

the Department of Labor website: [www.ctdol.state.ct.us](http://www.ctdol.state.ct.us). Such prevailing wage adjustment will not be considered a basis for an annual contract amendment.

4. I (We), the undersigned, hereby declare that I am (we are) the only person(s) interested in the proposal and that it is without any connection with any other person making any bid for the same work. No person acting for, or employed by, the State of Connecticut is directly interested in this proposal, or in any contract which may be made under it, or in expected profits to arise there from. This proposal is made without directly or indirectly influencing or attempting to influence any other person or corporation to bid or refrain from bidding or to influence the amount of the bid of any other person or corporation. This proposal is made in good faith without collusion or connection with any other person bidding for the same work and this proposal is made with distinct reference and relation to the plans and specifications prepared for this Contract. I (We) further declare that in regard to the conditions affecting the work to be done and the labor and materials needed, this proposal is based solely on my (our) investigation and research and not in reliance upon any representations of any employee, officer or agent of the State.
5. Each class of work set forth in a separate Section of the Specifications and designated as a subtrade in Item 2A of the proposal pages shall be the matter of a subcontract made in accordance with the procedures set forth in the Bid and Contract Documents.
6. The undersigned agrees that, if selected as General Contractor, he shall, within five (5) days, Saturdays, Sundays and legal holidays excluded, after presentation thereof by the University of Connecticut, execute a contract in accordance with the terms of this general bid.
7. The undersigned agrees and warrants that he has made good faith efforts to employ minority business enterprises as subcontractors and suppliers of materials under such contract and shall provide the Commission on Human Rights and Opportunities with such information as is requested by the Commission concerning his employment practices and procedures as they relate to the provisions of the Connecticut General Statutes governing contract requirements.
8. The undersigned agrees that if notice of acceptance of Bid is delivered to him within 120 calendar days from the date of bid opening, he will promptly execute a contract for the above stated compensation.

**BID FORM CONTINUED ON NEXT PAGE**

The undersigned proposes to furnish all labor and material required for:

**Project Name: Replacement CT Scanner  
Project Number: 08-050**

in accordance with the accompanying Drawings and Specifications prepared by

**Fletcher – Thompson, Inc.**

for the Contract Price specified below subject to additions and deductions according to the terms of the Contract Documents dated December 12, 2008.

**A. ADDENDA:**

This bid includes Addenda numbered: \_\_\_\_\_ Dated \_\_\_\_\_  
\_\_\_\_\_ Dated \_\_\_\_\_  
\_\_\_\_\_ Dated \_\_\_\_\_  
\_\_\_\_\_ Dated \_\_\_\_\_

**B. ALLOWANCES: not used**

OR

If used prepare schedule

**C. PROPOSED BASE CONTRACT PRICE:**

\_\_\_\_\_ \$ \_\_\_\_\_  
Written Figures

**D. SCHEDULE OF ALTERNATES:**

The undersigned Bidder further proposes and agrees that should the following Alternates be accepted and included in the Contract, the amount of the Lump Sum Bid, as heretofore stated, shall be adjusted by the amount of said Alternates. All materials and workmanship shall be in strict accordance with the Drawings and Specifications and shall be in-place prices.

**ADD Alternate No. 1:**

For the provision of all labor, materials, and equipment required for work related to fit-up of Equipment Room LM 079B, including but not limited to the following: 1. Demolition of ceilings, including ceiling pads and grid. 2. Relocation of light fixtures, sprinkler heads, HVAC diffusers, smoke detectors, speakers, etc. 3. Demolition of electrical equipment including duplex receptacles, wiring, etc. 4. Installation of new sheetrock walls, door frame, doors, hardware. 5. Installation of new ceiling including ceiling tile and grid. 6. Installation of new UPS equipment including rigging, interconnection conduit and wiring per Siemens drawings, EPO switch, new AC-2 and CU-2, new Panel 'CT', including all mechanical piping and supports, core drilling, ceiling work for installation of new piping



and electrical wiring, conduit and wiring, fire-stopping, access doors, junction boxes, etc.  
7. Testing and balancing.

as detailed in the Drawings and Specifications **ADD** to the Base Bid a lump sum of:

\_\_\_\_\_ Dollars (\$) \_\_\_\_\_  
(Written) (Figures)

**E. SCHEDULE OF UNIT PRICES: not used**

OR

If used prepare schedule, see example below

The cost of material and labor to patch miscellaneous holes in rated partitions. Proposed patch work shall match the existing construction where the hole(s) are located.

**Unit Price No. 1:**

\_\_\_\_\_ / SF Masonry

\_\_\_\_\_ / SF Gypsum

**F. SCHEDULE OF OPTIONS: not used**

OR

If used prepare schedule

**G. SUBDIVISION OF CONTRACT PRICE:**

The subdivision of the proposed Contract Price is as follows:

**ITEM 1A** Subcontractors and prices for the following trades must be listed (if such prices exceed \$25,000.00). However, the general bidder may list himself together with his price if he customarily performs any of the trades specified. If the general contractor requires a performance and/or labor & material payment bond then the general contractor must indicate below which of the subcontractors are subject to this requirement. The amount (%) shall not exceed the subcontractor's price listed below.

DESCRIPTION	NAME OF SUBCONTRACTOR	DOLLAR AMOUNT	LABOR & MATERIAL BOND	PERFORMANCE BOND
MASONRY				
ELECTRICAL				
MECHANICAL WITHOUT HVAC				
HVAC				

The undersigned agrees that each of the subcontractors listed on this BID FORM will be used for the work indicated at the amount stated, unless a substitution is permitted by the University of Connecticut Health Center. Such permission shall only be granted for “good cause” as defined by Connecticut General Statute Section 4B-95(C).

**ITEM 1B SCHEDULE OF VALUES:**

The undersigned agrees that the Schedule of Values submitted with this Bid is a true representation of the distribution of the costs of this project and **equals the Proposed Base Contract Price shown above**. The Schedule of Values is an integral part of this proposal. Please indicate N/A for those divisions of work not applicable.

**SCHEDULE OF VALUES**

Division 1, General Requirements	_____
Division 2, Site Construction	_____
Division 3, Concrete	_____
Division 4, Masonry	_____
Division 5, Metals	_____
Division 6, Wood & Plastic	_____
Division 7, Thermal and Moisture Protection	_____
Division 8, Doors & Windows	_____
Division 9, Finishes	_____
Division 10, Specialties	_____
Division 11, Equipment	_____
Division 12, Furnishings	_____
Division 13, Special Construction	_____
Division 14, Conveying Systems	_____
Division 15, Mechanical	_____
Division 16, Electrical	_____

**TOTAL OF PROPOSED BASE CONTRACT PRICE** \_\_\_\_\_

H. CONTRACTORS CERTIFICATION

We certify that we are familiar with the contents of the Contract Documents for this project and that we have examined the site and accept the conditions under which the work will be done.

NOTE: All proposals must be signed by a duly authorized representative of the firm. NO FACSIMILE SIGNATURE PERMITTED.

If this proposal is being submitted by a Joint Venture, each Joint Venture shall sign the Proposal, and each Joint Venture agrees to be bound by the terms and conditions thereof.

Signed the \_\_\_\_\_ day of \_\_\_\_\_ 20\_\_\_\_.

Project Number: \_\_\_\_\_

(TO BE FILLED IN AND SIGNED BY THE BIDDER)

Firm Name: \_\_\_\_\_

Street: \_\_\_\_\_

City/State/Zip Code: \_\_\_\_\_

Telephone: \_\_\_\_\_

Fax Number: \_\_\_\_\_

Duly Authorized Signature: \_\_\_\_\_

Name / Title \_\_\_\_\_

(TO BE FILLED IN AND SIGNED BY JOINT VENTURE IF APPLICABLE)

Firm Name: \_\_\_\_\_

Street: \_\_\_\_\_

City/State/Zip Code: \_\_\_\_\_

Telephone: \_\_\_\_\_

Fax Number: \_\_\_\_\_

Duly Authorized Signature: \_\_\_\_\_

Name / Title \_\_\_\_\_

Duly Authorized Signature: \_\_\_\_\_

Name / Title \_\_\_\_\_

END OF SECTION

THIS PAGE INTENTIONALLY LEFT BLANK

UNIVERSITY OF CONNECTICUT HEALTH CENTER  
FACILITY CONTRACTS & LEASES  
263 Farmington Avenue, MC4039  
Farmington, CT 06032

<b>Bid Number</b> <b>4-0015</b>
<b>Bid Due Date:</b> <b>January 28, 2009</b>

Jennifer K. Kelley  
Senior Purchasing Officer

860-679-1988  
Telephone Number

**Bid: 4-0015**

**Addendum Number: 1**

**Title: CT Scanner Replacement**

**For: The University of Connecticut Health Center**

**Bidders Note:**

Please incorporate the information found on the following pages into your bid specification package.

Due date has been extended to January 28, 2009 at 2:30 PM.

All other terms & conditions remain unchanged

End of Addendum

This Addendum must be *Signed & Returned* with your bid.

\_\_\_\_\_

Authorized Signature of Bidder

\_\_\_\_\_

Company Name

Approved \_\_\_\_\_  
Jennifer K. Kelley  
Purchasing Services Officer  
(Original signature on file in Facility Contract & Leases)

Dated Issued: January 15, 2009

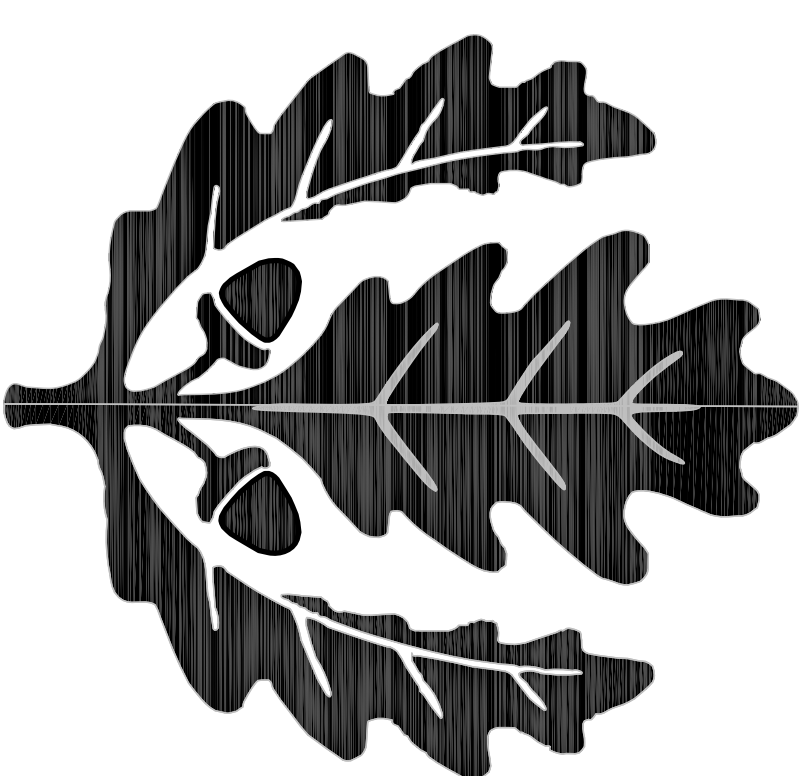

# University of Connecticut Health Center

## REPLACEMENT CT SCANNER UCHC PROJECT NO. 08-050

263 FARMINGTON AVENUE  
FARMINGTON, CONNECTICUT

ADDENDUM 1

PREPARED BY:

 **FLETCHER THOMPSON**

ARCHITECTURE / ENGINEERING / INTERIOR DESIGN

THREE CORPORATE DRIVE / SHELTON, CT 06484-6344 / 203-225-6500 / FAX: 203-225-6800  
750 MAIN STREET / HARTFORD, CT 06103-2703 / 860-249-0888 / FAX 860-246-7206  
27 SCHOOLHOUSE ROAD / SOMERSET, NJ 08873-1212 / 732-907-6800 / FAX 732-907-6801  
345 SEVENTH AVENUE / SUITE 15N / NEW YORK, NY 10001 / 212-695-4767 / FAX 212-697-4767  
6645 WILLOW PARK DRIVE / SUITE 200 / NAPLES, FL 34109 / 239-667-1220 / FAX 239-667-1221

MEP ENGINEERS:

CONSULTING ENGINEERING SERVICES  
8111 MIDDLE STREET  
MIDDLETOWN CONNECTICUT 06457

JANUARY 13, 2004  
FT PROJECT NO. H080280

**UCONN HEALTH CENTER  
REPLACEMENT CT SCANNER  
PROJECT NUMBER 08-050  
FARMINGTON, CONNECTICUT**

The following changes to the Drawings and Project Manual shall become a part of the Drawings, Bidding Requirements, and Contract Documents; superseding previously issued Drawings, Bidding Requirements and Contract Documents, to the extent modified by this Addendum No. 1.

**NEW DRAWINGS**

The following drawings, dated January 13, 2009, unless otherwise indicated, attached to this Addendum, are hereby made part of the Contract Documents.

Dwg No.

Title

G100 – EGRESS, FIRE SAFETY AND RATING PLAN  
A001 – OVERALL SCOPE PLAN AND NOTES  
A010 – DEMOLITION FLOOR PLAN AND DEMOLITION REFLECTED CEILING  
A110 – PARTIAL PLAN WITH ROOF FRAMING AND ROOF DETAILS

**REVISED DRAWINGS**

The following drawings, dated January 13, 2009, unless otherwise indicated, attached to this Addendum, are hereby made part of the Contract Documents.

Dwg No.

Title

----- – COVER SHEET  
G001 – GENERAL INFORMATION  
A100 – NEW PLAN AND NEW REFLECTED CEILING PLAN  
A101 – INTERIOR ELEVATIONS AND SECTIONS

**REVISED MEP DRAWINGS**

Revise various plumbing, fire protection, mechanical, and electrical Drawings as indicated on attached Addendum No. 1 prepared by Consulting Engineering Services, Inc.

**CHANGES TO PROJECT MANUAL**

**NEW SPECIFICATION SECTIONS**

The following new specification sections, dated January 13, 2009, unless otherwise indicated, attached to this Addendum, are hereby made part of the Contract Documents.

Section No.                      Title

07720 – Roof Accessories

**REVISED SPECIFICATION SECTIONS**

The following revised specification sections, dated January 13, 2009, unless otherwise indicated, attached to this Addendum, are hereby made part of the Contract Documents.

Section No.                      Title

Attachment A - Table of Contents

01020 – Construction Area Environmental Control Class III/IV

06400 – Architectural Millwork

08210 – Wood Doors

09510 – Acoustical Ceilings

**END OF ADDENDUM NO. 1**





## Addendum

Addendum Number: 1  
Addendum Date: January 14, 2008  
Written To: Vikas Nagardeoleker - Fletcher-Thompson Inc.  
Project Name: UCHC Replacement CT Scanner  
UCHC Project No.: 08-050  
CES Project Number: 28145.00  
Written By: Loren Grabinsky

The work shall be carried out in accordance with the following supplemental instructions and in accordance with the Contract Documents.

### Description:

#### Plumbing and Fire Protection Drawings:

1. On drawing PFP-1, SCANNER ROOM PLUMBING AND FIRE PROTECTION PLAN, dated December 12, 2008, **REVISE** the drawing as indicated in the attached sketch SKPFP-01.

#### Mechanical Drawings:

1. For routing of mechanical piping, see the attached drawing SKM-01.
2. On drawing MD-1, SCANNER ROOM MECHANICAL DEMOLITION PLAN, dated December 12, 2008, **REVISE** the drawing as indicated in the attached sketch SKM-02.
3. On drawing M-1, SCANNER ROOM MECHANICAL PLAN, dated December 12, 2008, **REVISE** the drawing as indicated in the attached sketch SKM-01, SKM-03 & SKM-04.
4. On drawing M-2, MECHANICAL SCHEDULES & DETAILS, dated December 12, 2008, **REVISE** the drawing as indicated in the attached sketch SKM-05.

#### Electrical Drawings:

1. For routing of electrical wiring, see the attached drawing SKE-01.

2. On drawing ED-1, SCANNER ROOM ELECTRICAL DEMOLITION PLAN, dated December 12, 2008, **REVISE** the drawing per the attached sketch SKE-01.
3. On drawing EP-1, SCANNER ROOM ELECTRICAL POWER PLAN, dated December 12, 2008, **REVISE** the drawing per the attached sketch SKE-02. SKE-03, SKE-04, SKE-05 & SKE-06
4. On drawing EL-1.02, SCANNER ROOM ELECTRICAL LIGHTING PLAN, dated December 12, 2008, **REVISE** the drawing per the attached sketch SKE-07.

End of Addendum No. 1

Attachments: Sketches: SKPFP-01, SKM-01, SKM-02, SKM-03, SKM-04, SKE-01, SKE-02, SKE-03, SKE-04, SKE-05, SKE-06 & SKE-07

P:\28145.00\CA\Addendum\Addendum#1.doc

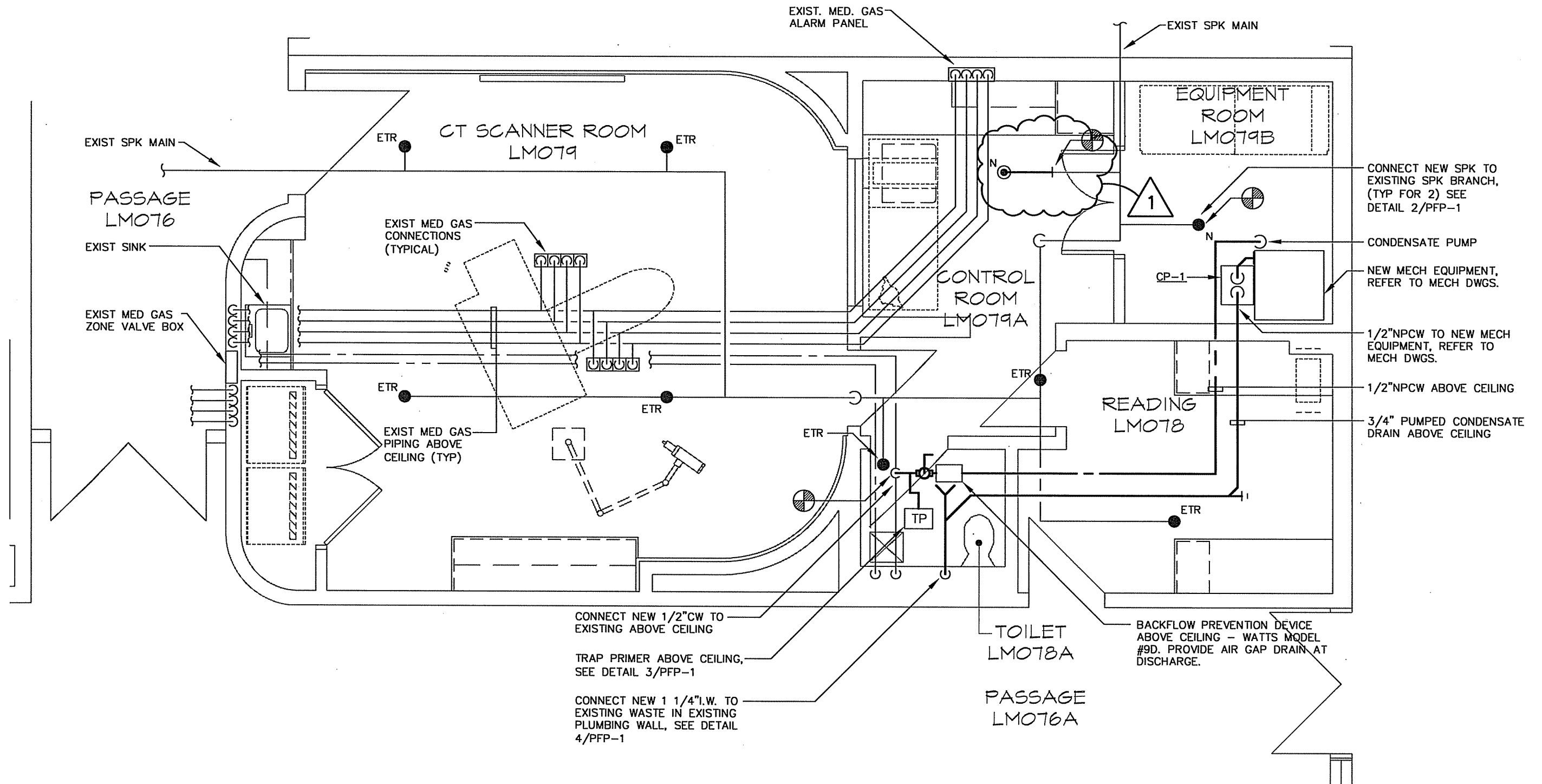

**1 SCANNER ROOM PLUMBING & FIRE PROTECTION PLAN**  
 SCALE: 1/4"=1'-0"

**FLETCHER THOMPSON**  
 ARCHITECTURE / ENGINEERING / INTERIOR DESIGN  
 THREE CORPORATE DRIVE  
 SHELTON, CT 06484-6244

PROJECT TITLE: **UCHU REPLACEMENT CT SCANNER** DATE: JANUARY 13, 2009  
 DWG. TITLE: **SCANNER RM. PLUMB. & F.P. PLAN** PROJECT NO.: H080380  
 DRAWN BY: JAG SCALE: AS NOTED DWG. NO.: ADD #1 SKFP-01

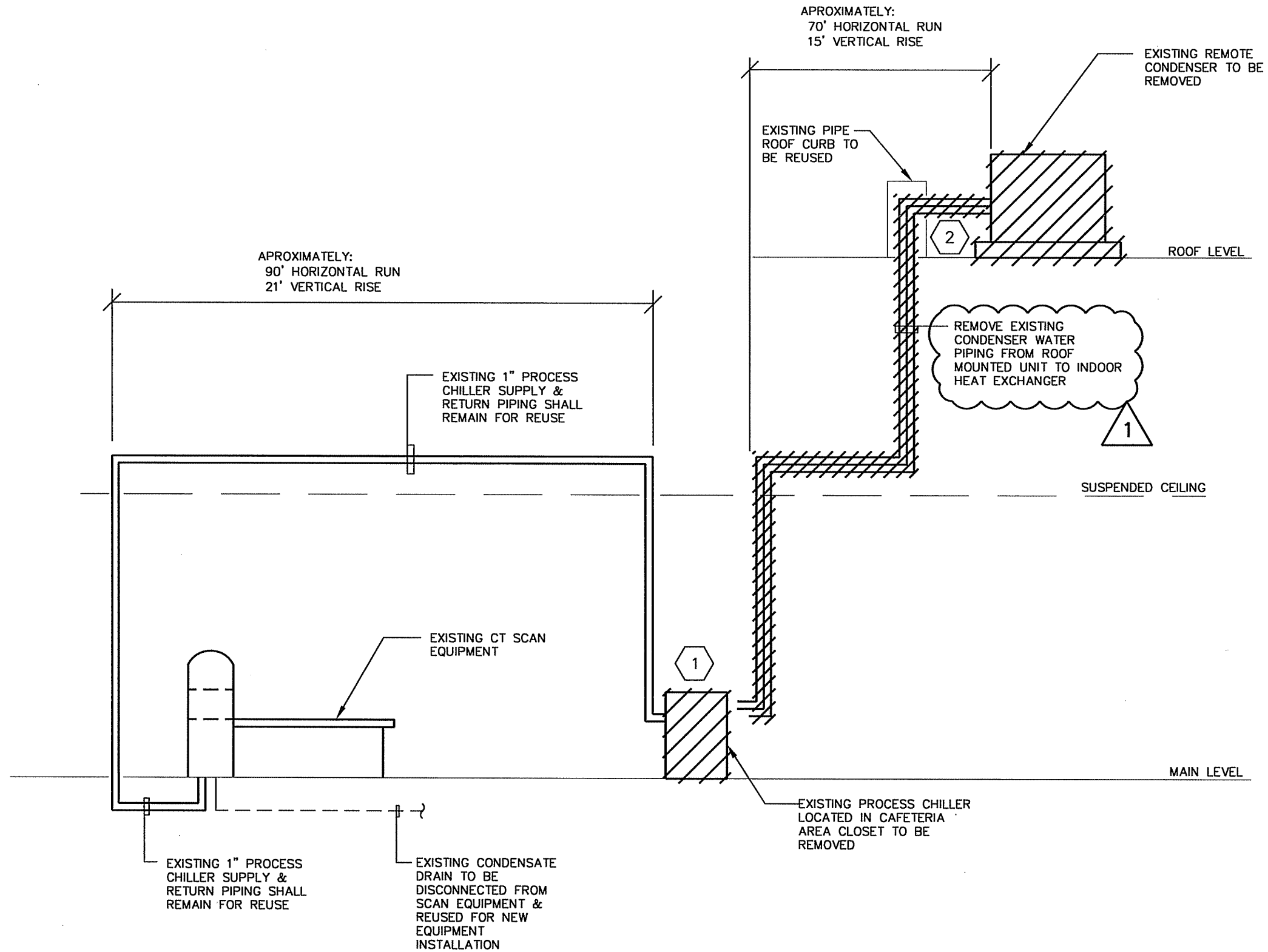

**2 EXISTING CHILLED WATER SYSTEM FLOW DIAGRAM**  
SCALE: N.T.S.

**FLETCHER THOMPSON**  
ARCHITECTURE / ENGINEERING / INTERIOR DESIGN  
THREE CORPORATE DRIVE  
SHELTON, CT 06484-6244

PROJECT TITLE: <b>UCHU REPLACEMENT CT SCANNER</b>	DATE: JANUARY 13, 2009
DWG. TITLE: <b>SCANNER RM. MECH. DEMO. PLAN</b>	PROJECT NO.: H080380
DRAWN BY: AC	SCALE: AS NOTED
	DWG. NO.: ADDEN #1 SKM-02

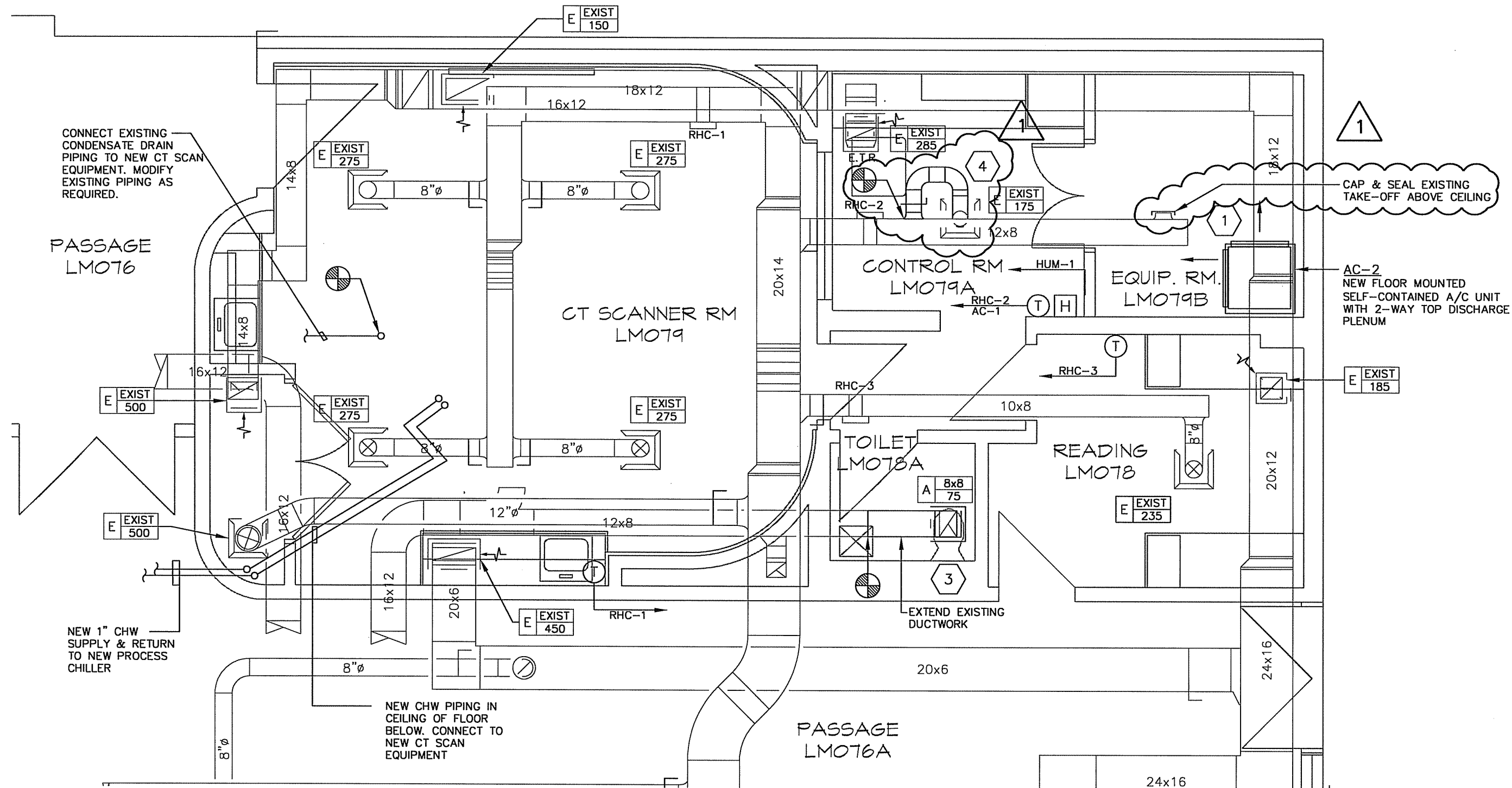

**1 SCANNER ROOM MECHANICAL PLAN**  
 SCALE: 1/4"=1'-0"

**FLETCHER THOMPSON**  
 ARCHITECTURE / ENGINEERING / INTERIOR DESIGN  
 THREE CORPORATE DRIVE  
 SHELTON, CT 06484-6244

PROJECT TITLE: <b>UCHU REPLACEMENT CT SCANNER</b>	DATE: JANUARY 13, 2009
DWG. TITLE: <b>SCANNER RM. MECHANICAL PLAN</b>	PROJECT NO.: H080380
DRAWN BY: AC	SCALE: AS NOTED
	DWG. NO.: ADDEN #1 SKM-03

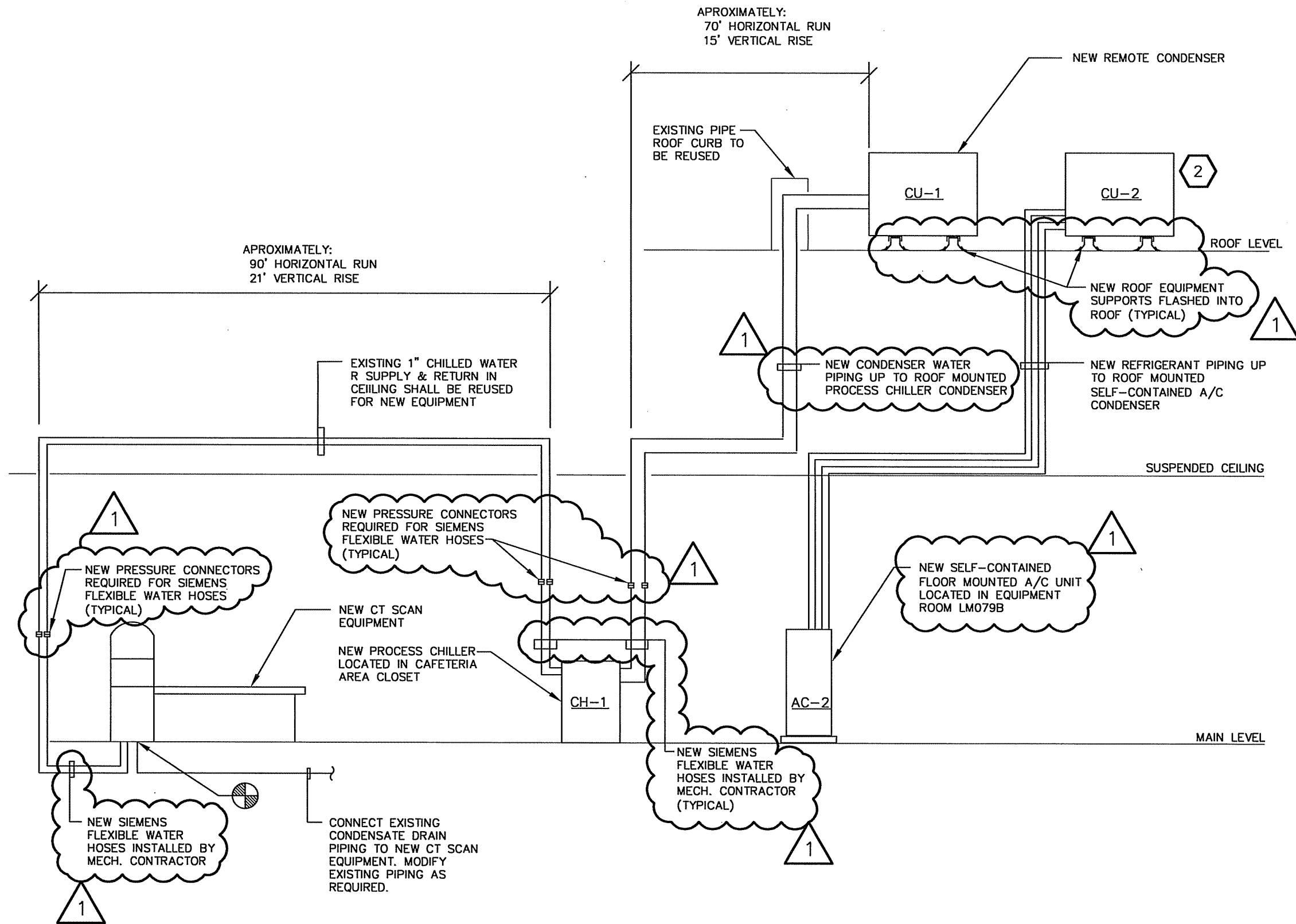

**2 NEW CHILLED WATER SYSTEM FLOW DIAGRAM**  
SCALE: N.T.S.

**FLETCHER THOMPSON**  
ARCHITECTURE/ENGINEERING/INTERIOR DESIGN  
THREE CORPORATE DRIVE  
SHELTON, CT 06484-6244

PROJECT TITLE: <b>UCHU REPLACEMENT CT SCANNER</b>	DATE: JANUARY 13, 2009
DWG. TITLE: <b>SCANNER RM. MECHANICAL PLAN</b>	PROJECT NO.: H080380
DRAWN BY: AC	SCALE: AS NOTED
	DWG. NO.: ADDEN #1 SKM-04

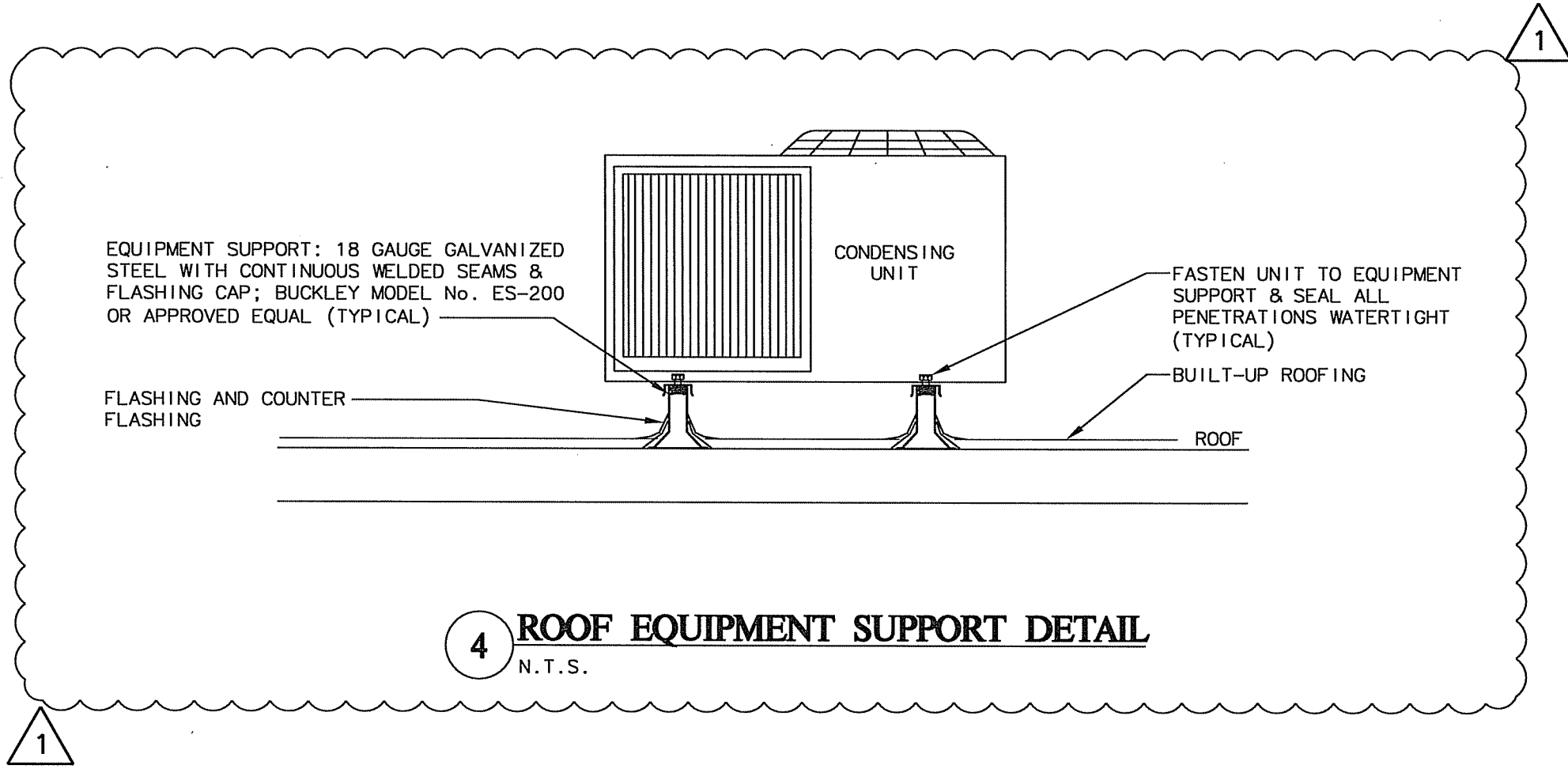

**4** ROOF EQUIPMENT SUPPORT DETAIL  
N.T.S.





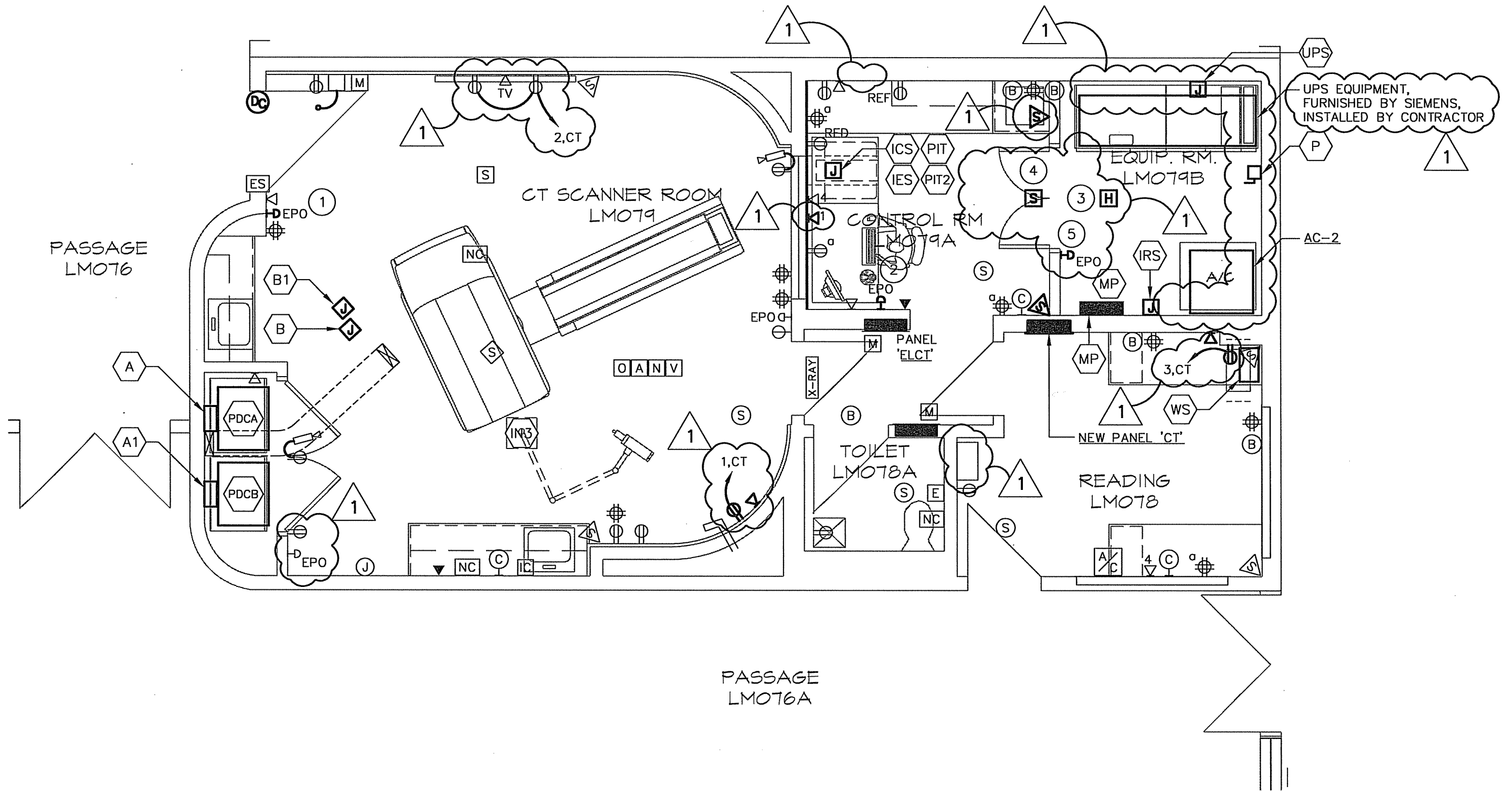

**1 SCANNER ROOM ELECTRICAL POWER PLAN**  
 SCALE: 1/4"=1'-0"

**FLETCHER THOMPSON**  
 ARCHITECTURE / ENGINEERING / INTERIOR DESIGN  
 THREE CORPORATE DRIVE  
 SHELTON, CT 06484-6244

PROJECT TITLE: <b>UCHU REPLACEMENT CT SCANNER</b>	DATE: JANUARY 13, 2009
DWG. TITLE: <b>SCANNER RM. ELECT. POWER PLAN</b>	PROJECT NO.: H080380
DRAWN BY: LMG	SCALE: AS NOTED
	DWG. NO.: ADDEN #1 SKE-03

**NOTE:**

CONTRACTOR SHALL INCLUDE ALL WORK ASSOCIATED WITH CONDUIT, BOXES, WIRING, CORE DRILLING, ETC AS INDICATED ON/IN THE DRAWING PROVIDED & PRODUCED BY SIEMENS, PROJECT NUMBER 0800962. REFER TO THESE DRAWINGS FOR (WS), (MP), ETC.































1

**ELECTRICAL NEW WORK NOTES**

- ① RELOCATE EXISTING EPO SWITCH AND CONNECT TO NEW SIEMENS EQUIPMENT. SEE SEIMENS DRAWINGS FOR ADDITIONAL INFORMATION.
- ② EXISTING EPO SWITCH TO REMAIN IN LOCATION INDICATED. CONNECT TO NEW SIEMENS EQUIPMENT. SEE SIEMENS DRAWINGS FOR ADDITIONAL INFORMATION.
- ③ PROVIDE NEW CEILING MOUNTED HEAT DETECTOR CONNECTED TO BUILDING FIRE ALARM SYSTEM.
- ④ RELOCATED SMOKE DETECTOR. SEE DEMO PLANS.
- ⑤ NEW EPO SWITCH CONNECTED TO NEW SIEMENS EQUIPMENT. SEE SIEMENS DRAWINGS FOR ADDITIONAL INFORMATION.

1

## ELECTRICAL SYMBOL LIST

SYMBOL	DESCRIPTION	SYMBOL	DESCRIPTION
	CEILING MOUNTED PUBLIC ADDRESS SYSTEM SPEAKER		FIRE ALARM SYSTEM CEILING MOUNTED SMOKE DETECTOR
	PUBLIC ADDRESS SYSTEM WALL MOUNTED SPEAKER, WP-INDICATES WEATHERPROOF		CEILING MOUNTED HEAT DETECTOR - TEMPERATURE RATING AS INDICATED ON DRAWINGS, 165°F FIXED.
	WALL MOUNTED CLOCK, WG-INDICATES WIRE GUARD		MAGNETIC DOOR HOLD OPEN DEVICE
	DATA OUTLET, TWO GANG BACKBOX WITH (2) 3/4" CONDUIT AND BUSHING STUBBED INTO ACCESSIBLE CEILING SPACE. PROVIDE EMPTY CONDUIT WITH NYLON PULL STRING. WIRING BY OWNER.		FLUSH MOUNTED PANELBOARD
	SINGLE POLE TOGGLE SWITCH		SURFACE MOUNTED PANELBOARD
	THREE WAY TOGGLE SWITCH		DUPLEX RECEPTACLE, NUMBER INDICATES MOUNTING HEIGHT ABOVE FINISH FLOOR
	WALL MOUNTED OCCUPANCY SENSOR		DUPLEX RECEPTACLE WITH GROUND FAULT CIRCUIT INTERRUPTION
	WALL MOUNTED DIMMER SWITCH		DUPLEX RECEPTACLE, MOUNT ABOVE COUNTER HEIGHT
	WALL MOUNTED VOLUME SWITCH		DOUBLE DUPLEX RECEPTACLE
	CEILING MOUNTED OCCUPANCY SENSOR		SIMPLE RECEPTACLE
	SECURITY INTERCOM STATION		JUNCTION BOX - SQUARE
	EMERGENCY CALL-FOR-AID TOGGLE SWITCH		JUNCTION BOX - ROUND
	NURSE CALL-FOR-AID		DISCONNECT
	RECESSED FLUORESCENT LIGHTING FIXTURE		JUNCTION BOX WITH BLANK COVER PLATE
	SECURITY CAMERA		TV CABLE OUTLET - 2 GANG BACKBOX WITH 3/4" CONDUIT WITH PLASTIC BUSHINGS AT EACH END & NYLON PULLSTRING STUBBED INTO ACCESSIBLE CEILING SPACE. WIRING BY OWNER.

1

1

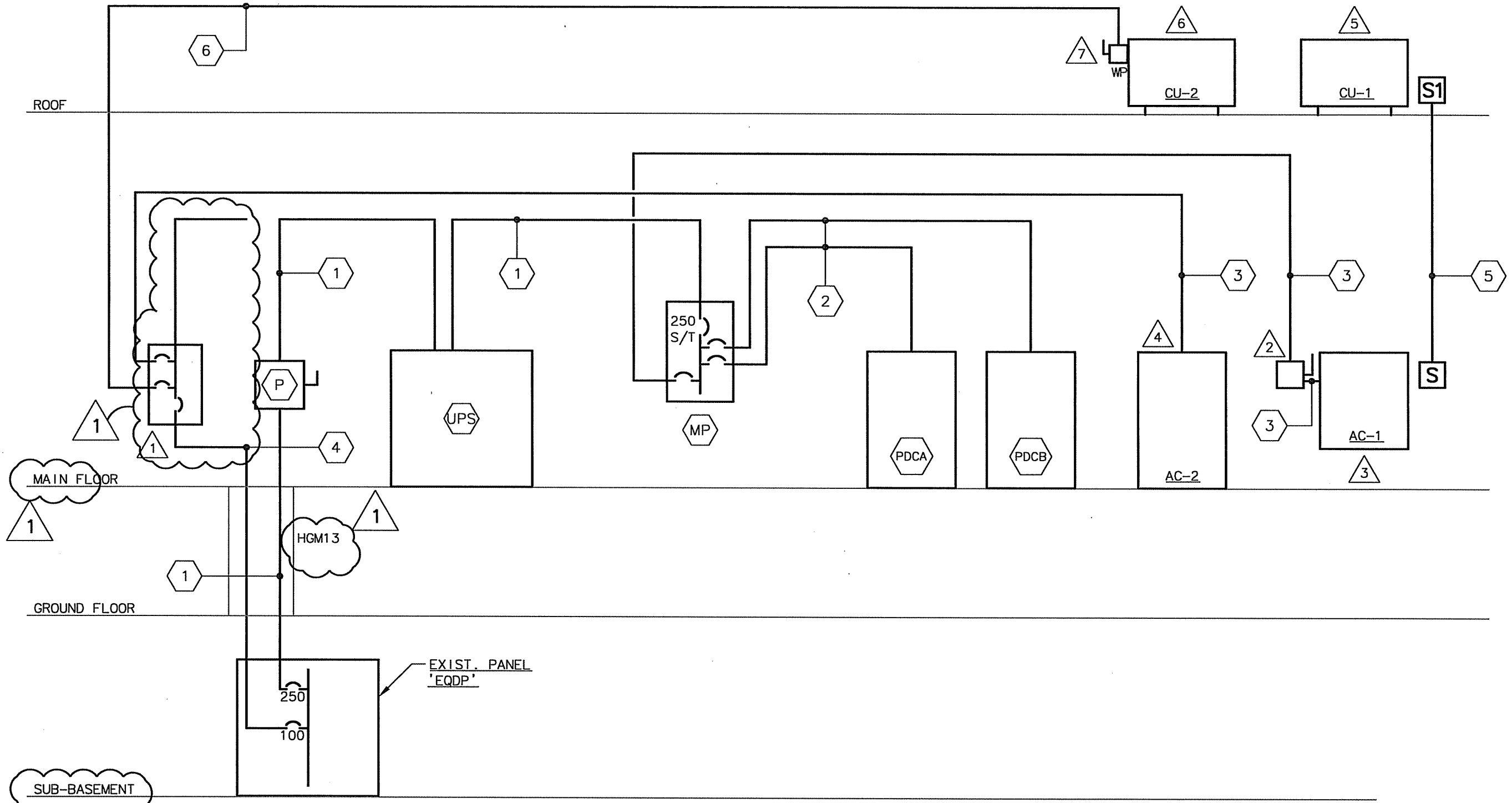

**2 POWER RISER DIAGRAM**  
SCALE: N.T.S.

**FLETCHER THOMPSON**  
ARCHITECTURE / ENGINEERING / INTERIOR DESIGN  
THREE CORPORATE DRIVE  
SHELTON, CT 06484-6244

PROJECT TITLE: <b>UCHU REPLACEMENT CT SCANNER</b>	DATE: JANUARY 13, 2009
DWG. TITLE: <b>SCANNER RM. ELECT. POWER PLAN</b>	PROJECT NO.: H080380
DRAWN BY: LMG	SCALE: AS NOTED
	DWG. NO.: ADDEN #1 SKE-06

## GENERAL LIGHTING NOTES

1. ALL CIRCUITS SHALL BE 2#12, #12G., 3/4"C., TO NEW 20A-1P CIRCUIT BREAKER IN PANEL INDICATED UNLESS NOTED OTHERWISE.
2. ALL 120VAC BRANCH CIRCUITS EXCEEDING 150' IN LENGTH SHALL BE INCREASED TO 2#10, #10G., 3/4"C. UNLESS NOTED OTHERWISE.
3. EMERGENCY LIGHTING AND EXIT SIGNS SHALL BE WIRED TO LINE SIDE OF LOCAL LIGHTING BRANCH CIRCUIT, AHEAD OF ALL SWITCHING DEVICES.
4. REFER TO ARCHITECTS REFLECTED CEILING PLAN FOR EXACT LOCATIONS OF CEILING MOUNTED DEVICES.
5. REFER TO DRAWING EP-1 FOR SYMBOL LIST.

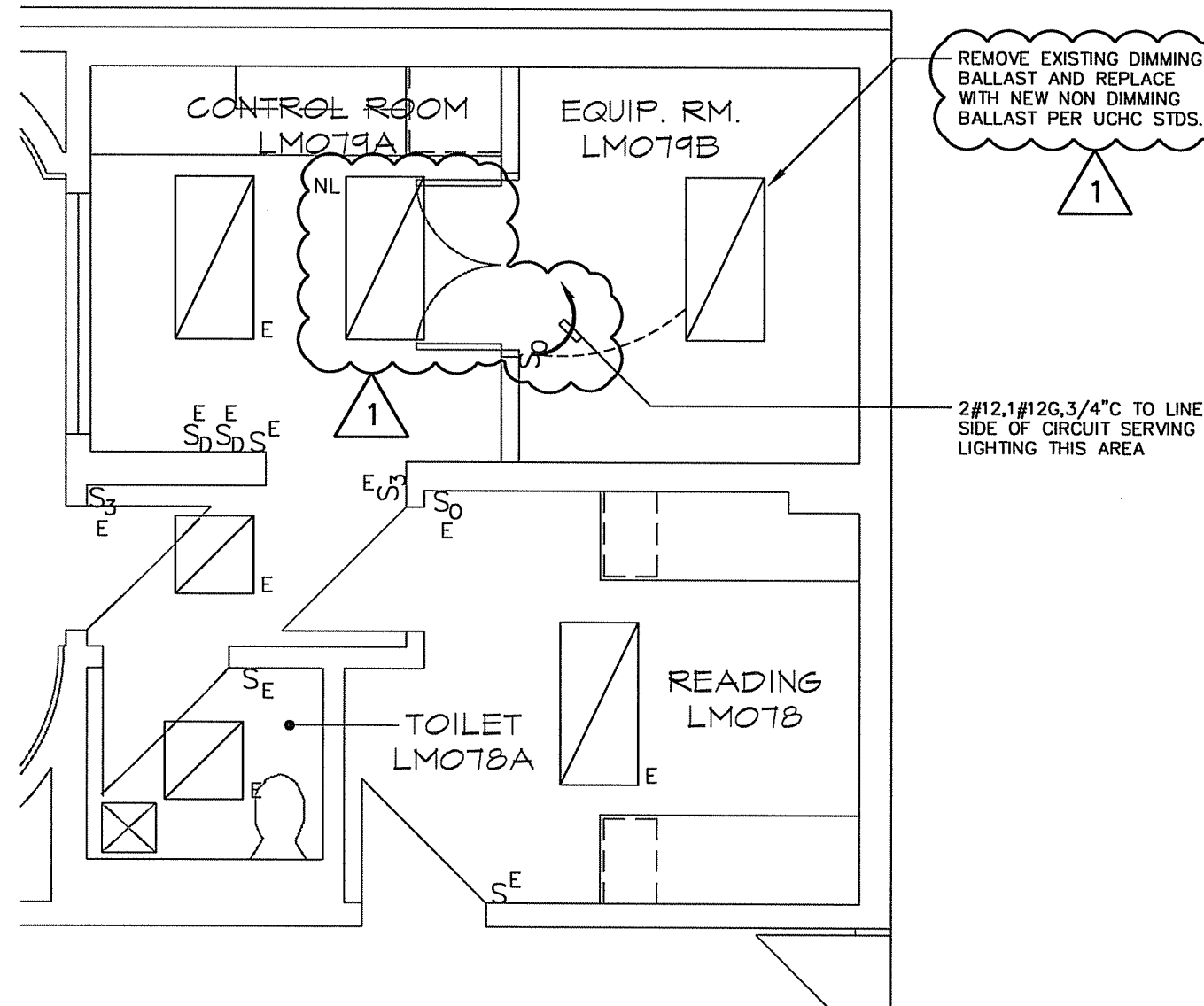

**1 SCANNER ROOM ELECTRICAL LIGHTING PLAN**  
SCALE: 1/4"=1'-0"

ATTACHMENT - A

**UNIVERSITY OF CONNECTICUT  
HEALTH CENTER  
REPLACEMENT CT SCANNER**

**TABLE OF CONTENTS**

**I. PROJECT MANUAL**

**Division 0 - General Conditions**

Table of Contents	4
List of Drawings	2
Instructions to Bidders AIA A 701	6
Contractor's Qualification Statement AIA A-305	4
Bid Form	8
Bid Bond	2
UCONN Performance Bond	1
UCONN Payment Bond	1
Standard Form of Agreement Between Owner and Contractor, AIA A-101	14
General Conditions, AIA A-201	106
Application for Payment, AIA G-702/703	4
List of Subcontractors, UCHC FORM 550.13A	2
Background Information Sheet	1

**Division 1 - General Requirements**

01015	General Project Requirements	10
01018	Special Project Procedures	4
01020	Construction Area Environmental Control - Class 3, 4	6
01045	Cutting and Patching	4
01300	Submittals	6
01631	Product Substitutions	4
01700	Project Closeout	4
01710	Project Cleaning	4

01740	Warranties and Bonds	2
-------	----------------------	---

**Division 2 - Site Work**

02070	Selective Demolition	8
-------	----------------------	---

**Division 3 - Concrete**

Not Used

**Division 4 - Masonry**

Not Used

**Division 5 - Metals**

Not Used

**Division 6 - Wood and Plastics**

06100	Rough Carpentry	6
06200	Finish Carpentry	4
06400	Architectural Millwork	10

**Division 7 - Thermal and Moisture Protection**

07720	Roof Accessories	4
07841	Through-Penetration Firestop System	10
07920	Joint Sealants	4

**Division 8 - Doors and Windows**

08111	Steel Frames	4
08210	Wood Doors	6
08710	Finish Hardware	8

**Division 9 - Finishes**

09110	Non-Load-Bearing Wall Framing	4
09250	Gypsum Board	6
09510	Acoustical Ceilings	4
09653	Resilient Wall Base and Accessories	6
09900	Paints and Coatings	12

**Division 10 - Specialties**

Not Used

**Division 11 - Equipment**

Not Used

**Division 12 - Furnishings**

Not Used

**Division 13 - Special Construction**

Not Used

**Division 14 - Conveying Systems**

Not Used

**Division 15 - Mechanical**

15010	General Conditions for Mechanical Trades	--
15050	Basic Mechanical Materials and Design Parameters	--
15260	Mechanical Insulation	--
15300	Fire Protection Systems	--
15400	Plumbing Systems	--
15410	Plumbing Piping	--
15420	Valves	--
15421	Backflow Prevention Devices	--
15453	Plumbing Pumps	--
15500	HVAC Systems	--
15530	Refrigerant Piping	--
15680	Chillers and Accessories	--
15751	Packaged Heat Transfer Equipment	--
15850	Air Handling	--
15890	Ductwork and Ductwork Accessories	--
15970	Control Systems Equipment	--
15990	Testing, Adjusting, and Balancing	--
15995	Air Flow Testing	--

**Division 16 - Electrical**

16010	General Conditions for Electrical Trades	--
16050	Basic Electrical Materials and Methods	--
16504	Occupancy Sensors	--
16510	Interior Lighting	--
16615	Emergency Lighting	--
16725	Fire Alarm System	--
16740	Telecommunications Outlets	--

END OF TABLE OF CONTENTS



THIS PAGE INTENTIONALLY LEFT BLANK

**SECTION 01020  
CONSTRUCTION AREA ENVIRONMENTAL CONTROL  
CLASS III/IV**

**PART 1 - GENERAL**

1.01 SUMMARY

- A. The Contractor will be required to work in areas occupied by or adjacent to areas occupied by employees of the University of Connecticut Health Center. All work must be planned and done in a manner so that the continued Health Center operations is not compromised and shall follow procedures set-forth herein to ensure that the environment for occupied areas is fully maintained.
- B. The Contractor(s) shall, be required to follow the guidelines below throughout the constructed period. These guidelines address:
  - The erection of construction barriers
  - Entrances and exits to work area
  - Maintaining a clean work environment
  - Providing negative air pressure within the construction area
  - Post construction procedures
  - Protection of occupied areas including controls on the transportation of materials and debris
  - Training of contractor personnel
  - Daily Compliance Survey
- C. All precautionary measures shall be reviewed and accepted by the UCHC Agent(s) prior to the start of any work.
- D. Material Safety Data Sheets on materials used will be provided in hard copy to the UCHC Agent in advance of brining the materials into the UCHC.

1.02 RELATED DOCUMENTS

- A. Drawings and general provisions of Contract, including General and Supplementary Conditions and other Division-1 Specification Sections, apply to this Section.
- B. The Contractor shall coordinate the specific requirements of the following specification sections:
  - Section 01015 - GENERAL PROJECT REQUIREMENTS
  - Section 01018 - SPECIAL PROJECT PROCEDURES

**PART 2 -REQUIREMENTS**

2.01 CONSTRUCTION AND ENVIRONMENTAL CONTROL BARRIERS

- A. Construction and Environmental Control Barriers shall be erected to effectively seal off the construction area for all work phases from that of the areas remaining to be occupied by the owner. Locations of such barriers shall be as indicated on the project documents. Types of barriers to be erected may vary depending on location of the barrier and anticipated duration of time the barrier is to remain in place. Refer to Phasing and Environmental Control Plan for barrier descriptions and locations.

For work occurring outside of the project area, the Contractor shall erect environmental barriers as required to maintain the environment of the adjacent spaces. Refer to Items C and D below. Work occurring in such

areas shall have HEPA filtered negative air pressure from the surrounding area. The HEPA air filter shall be allowed to vent into the adjacent occupied space.

Prior to the start of the work, the Contractor shall present a plan for the erection of such barriers to the UCHC Agent. No work shall commence until the UCHC Agent accepts said plan.

- B. Project site must be completely contained by impervious barriers constructed and located in accordance with UCHC Fire Department requirements.
- C. Construction and Environmental Barriers used to define the project limits, located adjacent to corridors shall be erected of assemblies consisting of temporary sheet rock or plywood walls with metal studs.
- D. Construction and Environmental barriers used to encapsulate and control air borne contaminants shall be constructed of metal studs sheathed with firerated polyethylene. The use of zip poles for isolated activities for temporary support of polyethylene shall be acceptable.

Seams in Environmental Barriers shall be sealed with duct tape. All edge intersections with existing floor, wall and ceiling materials shall be sealed with duct tape.

Openings used for construction area access shall have overlap protection with not less than 24" of polyethylene overlap.

- E. Determination of type of barrier used will be based on type, location and length of anticipated project activity.
- F. All penetrations that would allow air circulation to a non-construction area shall be sealed.
- G. Impervious barriers will extend from the floor, beyond the false ceiling, to the underside of the floor above. Where plaster ceilings exists the barrier may terminate tight to the underside of the finished surface.
- H. Existing doors not used for entrances shall be sealed tight with duct tape applied over the frames and doors.

#### 2.02 ENTRANCES AND EXITS TO THE WORK AREA:

- A. Entrances and Exits to and from the work site for workman and the delivery of materials shall be limited to shown on the drawings.
- B. Entrances and exits to work site shall be pre-determined before start of project and shall be constructed of gasketed hollow metal door and frame units with self closing latching hardware as approved by the UCHC Agent.
- C. Separation Walls shall have negative pressure visual indicator devices installed (in construction barriers) at each construction area entrance / exit location.

#### 2.03 MAINTAINING A CLEAN WORK ENVIRONMENT

- A. Tack mats shall be placed outside the construction area door. Tack mats shall be changed as necessary to maintain clean environment.
- B. Dust tracked outside the barrier must be immediately cleaned, either by use of a HEPA-filtered vacuum and/or damp mopping

#### 2.04 NEGATIVE AIR PRESSURE

- A. After construction of the barriers and entrance to the work and approval by the UCHC Agent, the contractor will disconnect and/or cap supply air flow to construction area as directed by the UCHC Agent. Disconnect system at location where new supply ductwork will begin.
- B. Disconnect exhaust airflow ductwork to construction area at location where new exhaust ductwork will begin. Cap all exhaust air ducts except those (normally one) that will be used for exhaust air during construction. All exhaust ducts used during construction shall be filtered through a contractor installed 30% filter. Dirty air shall not be allowed to enter the exhaust system.
- C. Install portable HEPA air filtering system in construction area sized to provide a minimum of 15 air changes per hour. Aim exhaust air from HEPA filter system toward the main existing (30% filtered) exhaust duct, (approximately 6 inches away), do not connect directly to exhaust duct system. The HEPA filter system shall operate 24 hours a day, 7 days a week for the duration of the project.  
  
The portable HEPA air-filtering system shall be certified yearly and shall have the name of the certification company and the date certified attached to the unit.
- D. Negative pressure visual indicator devices shall be installed (in construction barriers) at construction area entrance location.
- F. Construction shall not begin until the above actions have been completed and the UCHC Agent authorizes the start of the work.

#### 2.05 POST CONSTRUCTION PROCEDURES

- A. When construction is completed the entire construction area shall be completely cleaned before the final supply ducts and exhausts duct are connected. This cleaning will be of all surfaces (new, existing, barriers, ceilings, walls, etc) and will be done by wet wiping and/or HEPA vacuuming until no visible dust exists (based on a survey by the UCHC Agent). At such time, an approval will be given by the UCHC Agent and then the Construction Barriers and then the HEPA filtering system can be removed.
- B. Remove barrier material carefully to minimize spreading of dirt, debris, and dust.
- C. Vacuum work area with HEPA filtered vacuums.
- D. Wet mop area with disinfectant. Sweeping of area shall be prohibited.
- E. Wet wipe all surfaces (walls, counters, doors, frames, projected edges) with disinfectant.
- F. Remove isolation of HVAC system in areas where work is being performed.

#### 2.06 PROTECTION OF OCCUPIED AREAS AND TRANSPORT OF MATERIALS

- A. Entrance and exit to work site shall be as approved by the UCHC Agent and will be routed away from patient flow as much as possible.  
  
Prior to leaving the construction area, all personnel shall remove any and all loose debris, dust, etc.
- B. Dumping of debris will only be at the location(s) authorized by the UCHC Agent.
- C. Removal of daily construction debris and staging of the area with new construction materials shall be by a predetermined and pre-approved route and shall be performed during off hours only.

- D. Transporting the debris from work site shall be done in clean and tightly covered carts to prevent airborne dust release, spills, etc.
- E. Fine debris likely to become easily airborne (e.g. floor sweepings ,dust from vacuum, etc) shall be placed in a suitable plastic bag which is then twisted and closed prior to placement in the transport cart.
- F. The shoes and clothing of workers and materials (e.g., carts) leaving the work area will be cleaned (e.g., HEPA vacuum), as necessary, so that dust release outside the area is prevented.
- G. The contractor shall carefully consider at the start of the project the need to protect by individual barriers items remaining in the work area in order to minimize the amount and time needed for cleaning such objects prior to seeking authorization from the UCHC Agent to remove barriers.

2.07 TRAINING

- A. Key supervisory personnel of the contractor and subcontractors will be trained on the importance of contamination control and the critical nature of the area(s) they will be working in by UCHC personnel prior to the start of work.
- B. These supervisory personnel will be responsible for training other site personnel on these matters and helping to enforce procedures.
- C. The Department of Epidemiology and Environmental Health and Safety Office will provide training assistance and/or training materials.

2.08 DAILY COMPLIANCE SURVEY

- A. The contractor shall ensure adherence to all policies and procedures for dust and debris prevention and containment throughout the construction period.
- B. The Contractor shall be required to compile and submit to the UCHC Agent(s), Daily Compliance Survey for the purposes of monitoring procedures required for the control of airborne contaminants.
- C. Throughout the period of construction the Contractor shall work with the UCHC Agent(s) to ensure that each item indicated is being addressed properly and that should problems occur that the proper corrective measures are implemented to the satisfaction of the UCHC Agent(s).
- D. Refer to form attached to the end of this section entitled:

**Daily Compliance Survey  
Control of Airborne Contaminants and Procedures for  
Environmental Control**

END OF SECTION

**DAILY COMPLIANCE SURVEY  
CONTROL OF AIRBORNE CONTAMINANTS AND PROCEDURES FOR  
ENVIRONMENTAL CONTROL**

Project Title: \_\_\_\_\_ Date: \_\_\_\_\_  
 Project No: \_\_\_\_\_ Time: \_\_\_\_\_  
 Location: \_\_\_\_\_  
 General Contractor: \_\_\_\_\_

	YES	NO	CORRECTED
<b>1. Training: Contractor/Subcontractor Personnel</b>	_____	_____	_____
• Trained on contamination control	_____	_____	_____
• Trained on entry/exit requirements	_____	_____	_____
• Trained on transport of materials_	_____	_____	_____
Comments: _____			

<b>2. Physical Containment for Work Area</b>			
• Barricades sealed, no penetrations	_____	_____	_____
• Walk off mats in place, clean	_____	_____	_____
• Entrance/Exit through double doors	_____	_____	_____
• Other entrance areas locked/sealed	_____	_____	_____
• Signs posted cautioning about spread of dust	_____	_____	_____
• Adjacent ceiling areas intact	_____	_____	_____
• Adjacent floors are clean, no dust tracked	_____	_____	_____
Comments: _____			

<b>3. Negative Air Pressure Containment</b>			
• HEPA unit on/exhaust air connected correctly	_____	_____	_____
• Negative pressure at barricade entrance (smoke check)	_____	_____	_____
• Negative pressure indicator working	_____	_____	_____
• All windows and doors closed behind barricade	_____	_____	_____
• Negative air discharge hoses intact	_____	_____	_____
Comments: _____			

<b>4. Jobsite</b>			
• Material routes, dumpster location as authorized	_____	_____	_____
• Project area clean, debris removed daily	_____	_____	_____
• Debris removed in suitable containers	_____	_____	_____
• Debris removed at time specified	_____	_____	_____
• Workers removing dust from shoes, clothing, material prior to exit	_____	_____	_____
Comments: _____			

**5. Occupied Areas**

- Work authorized and scheduled \_\_\_\_\_
- Anticipated utilities impact coordinated in advance with UCHC Agent \_\_\_\_\_
- Construction barricade in place, properly sealed \_\_\_\_\_
- Surrounding area clean \_\_\_\_\_
- Special vibration/noise control activities coordinated in advance with UCHC agent \_\_\_\_\_

Comments: \_\_\_\_\_  
\_\_\_\_\_

**6. UCHC Agent Authorizations**

- Barrier/Negative air approval prior to construction work \_\_\_\_\_
- Post construction work authorization to remove barriers/negative air machine \_\_\_\_\_
- Daily update with UCHC O.R. contact person \_\_\_\_\_

cc: Environmental Control Officer  
Dept of Epidemiology  
UCHC Agent

\_\_\_\_\_  
General Contractor

**PART 1 - GENERAL****1.1 RELATED DOCUMENTS**

- A. Drawings and general provisions of the Contract, including General and Supplementary Conditions and Division 1 specification sections, apply to this section.

**1.2 SECTION INCLUDES**

- A. Plastic-laminate cabinets.
- B. Plastic-laminate countertops.

**1.3 RELATED SECTIONS**

- A. Section 06100 - Rough Carpentry: Exposed framing, wood furring, blocking, shims, and hanging strips required for installing woodwork and concealed within other construction before woodwork installation.

**1.4 REFERENCES**

- A. American Hardboard Association (AHA):
  - 1. AHA A135.4, Basic Hardboard.
- B. American National Standards Institute (ANSI):
  - 1. ANSI A208.1, Particleboard.
  - 2. ANSI A208.2, Medium Density Fiberboard (MDF).
- C. ASTM International (ASTM):
  - 1. ASTM D523, Test Method for Specular Gloss.
  - 2. ASTM D5456, Specification for Evaluation of Structural Composite Lumber Products.
  - 3. ASTM E84, Test Method for Surface-Burning Characteristics of Building Materials.
- D. Builders Hardware Manufacturers Association (BHMA):
  - 1. BHMA A156.9, Cabinet Hardware.
  - 2. BHMA A156.11, Cabinet Locks.
  - 3. BHMA A156.18, Materials and Finishes.
- E. Laminating Materials Association (LMA):
  - 1. LMA EDG-1, Voluntary Product Standard and Typical Physical Properties of Edgebanding Materials.
  - 2. LMA SAT-1, Voluntary Product Standard and Typical Physical Properties of Saturated Paper Overlays.



- F. National Electrical Manufacturers Association (NEMA):
  - 1. NEMA LD3, High Pressure Decorative Laminates.
  - 2. DOC PS 1, U.S. Product Standard for Construction and Industrial Plywood.

## 1.5 DEFINITIONS

- A. Interior architectural woodwork includes wood furring, blocking, shims, and hanging strips for installing woodwork items unless concealed within other construction before woodwork installation.

## 1.6 SUBMITTALS

- A. Submit under provisions of Section 01300.
- B. Product Data: For panel products, high-pressure decorative laminate, adhesive for bonding plastic laminate, cabinet hardware and accessories, and finishing materials and processes.
- C. Shop Drawings: Show location of each item, dimensioned plans and elevations, large-scale details, attachment devices, and other components.
  - 1. Show locations and sizes of furring, blocking, and hanging strips, including concealed blocking and reinforcement specified in other sections.
  - 2. Show locations and sizes of cutouts and holes for plumbing fixtures, faucets, soap dispensers and other items installed in architectural woodwork.
- D. Samples for Verification:
  - 1. Plastic laminates, 8 by 10 inches, for each type, color, pattern, and surface finish, with 1 sample applied to core material.
  - 2. Corner pieces as follows:
    - a. Cabinet-front frame joints between stiles and rails, as well as exposed end pieces, 18 inches high by 18 inches wide by 6 inches deep.
  - 3. Exposed cabinet hardware and accessories, one (1) unit for each type and finish.
- E. Environmental Submittals:
  - 1. Composite wood manufacturer's product data for each composite wood product used indicating that the bonding agent contains no urea formaldehyde.
  - 2. Adhesive manufacturer's product data for each adhesive used indicating that the adhesive contains no urea formaldehyde.
- F. Woodwork Quality Standard Compliance Certificates: AWI Quality Certification Program certificates.
- G. Qualification Data: For installer.

## 1.7 QUALITY ASSURANCE

- A. Fabricator Qualifications: Shop that employs skilled workers who custom-fabricate products similar to those required for this project and whose products have a record of successful in-service performance.
- B. Installer Qualifications: Fabricator of products.
- C. Source Limitations: Engage a qualified woodworking firm to assume undivided responsibility for production of architectural woodwork with sequence-matched wood veneers
- D. Fire-Test-Response Characteristics: Where fire-retardant materials or products are indicated, provide materials and products with specified fire-test-response characteristics as determined by testing identical products per test method indicated by UL, ITS, or another testing and inspecting agency acceptable to authorities having jurisdiction. Identify with appropriate markings of applicable testing and inspecting agency in the form of separable paper label or, where required by authorities having jurisdiction, imprint on surfaces of materials that will be concealed from view after installation.
- E. Mockups: Build mockups to verify selections made under sample submittals and to demonstrate aesthetic effects and set quality standards for materials and execution.
  - 1. Approved mockups may become part of the completed Work if undisturbed at time of Substantial Completion.

## 1.8 DELIVERY, STORAGE AND HANDLING

- A. Do not deliver woodwork until painting and similar operations that could damage woodwork have been completed in installation areas. If woodwork must be stored in other than installation areas, store only in areas where environmental conditions comply with requirements specified in "Project Conditions" article.

## 1.9 PROJECT CONDITIONS

- A. Field Measurements: Where woodwork is indicated to fit to other construction, verify dimensions of other construction by field measurements before fabrication and indicate measurements on shop drawings. Coordinate fabrication schedule with construction progress to avoid delaying the Work.
  - 1. Locate concealed framing, blocking, and reinforcements that support woodwork by field measurements before being enclosed and indicate measurements on shop drawings.

## 1.10 COORDINATION

- A. Coordinate sizes and locations of framing, blocking, reinforcements, and other related units of Work specified in other sections to ensure that architectural woodwork can be supported and installed as indicated.

## PART 2 - PRODUCTS

### 2.1 MATERIALS

- A. General: Provide materials that comply with requirements of AWI's quality standard for each type of woodwork and quality grade specified, unless otherwise indicated.
- B. Wood Products: Comply with the following:
  - 1. Plywood: Laminated core plywood, thickness as indicated with hardwood veneer. Band exposed edges with hardwood to match plywood veneer.
  - 2. Softwood Plywood: DOC PS 1, Medium Density Overlay.
- C. Thermoset Decorative Panels: Particleboard or medium-density fiberboard finished with thermally fused, melamine-impregnated decorative paper complying with LMA SAT-1.
  - 1. Provide PVC or polyester edge banding complying with LMA EDG-1 on components with exposed or semi-exposed edges.
- D. Particle Board:
  - 1. All particleboard shall be Grade M-3 Industrial, according to the American National Standard (ANSI) for Mat-Formed Wood Particleboard, ANSI-A208.1-1993 and shall meet or exceed the following:
    - a. Density 47 lbs/cu.ft.
    - b. Moisture Content 6%
    - c. Modules of Rupture 2400 psi
    - d. Modules of Elasticity 450,000 psi
    - e. Internal Bond 80 psi
    - f. Hardness 900 pounds
    - g. Linear Expansion 0.30%
    - h. Thickness Tolerance +/- 0.005"
    - i. Face Screw Holding 325 pounds
    - j. Edge Screw Holding 275 pounds
- E. High-Pressure Decorative Laminate: NEMA LD 3, grades as indicated or, if not indicated, as required by woodwork quality standard.
  - 1. Available Manufacturers: Subject to compliance with requirements, manufacturers offering high-pressure decorative laminates that may be incorporated into the Work include, but are not limited to, the following:
    - a. Formica Corporation.
    - b. Nevamar Company, LLC; Decorative Products Div.
    - c. Pionite Decorative Surfaces
    - d. Wilsonart International; Div. of Premark International, Inc.

### 2.2 CABINET HARDWARE AND ACCESSORIES

- A. General: Provide cabinet hardware and accessory materials associated with architectural cabinets.

- B. Butt Hinges: Hinges shall be semi-concealed, self closing, 270 degree swing European 3 Knuckle style by Mepla with six way adjustment. Hinge knuckle must be inset flush with the outside of door edge for a full overlay door style. Hinges not inset or which have an exposed knuckle over 1" in length "SHALL NOT BE ACCEPTABLE". Hinge shall permit door to swing 270 degrees without binding. Doors under 36" high shall have two hinges; 36"-72" high shall have three hinges; over 72" high shall have four hinges.
- C. Wire Pulls: Back mounted, solid metal Amerock #BP978-26D, 3-1/2" Long.
- D. Cabinet Locks: All cabinets and at every door and drawer: Sugatsune or equal. Two keys at each lock, each room keyed alike.
- E. Catches: KV 916
- F. Drawer Slides: BHMA A156.9, B0509. KV 1429 and 8500 (file drawers)
- G. Track and Guides for Sliding Panels: BHMA A156.9
- H. Roller Catches: Ives 336B.
- I. Hardware Finishes: Comply with BHMA 1301 for finishes indicated by BHMA Code Numbers or if not otherwise indicated, provide finishes complying with requirements indicated below:
  - 1. For exposed hardware comply with requirements indicated for finish and base indicated by BHMA Code Number below:
    - a. 630 (Satin stainless steel).
  - 2. For concealed hardware provide manufacturer's standard finish which complies with product class requirements of ANSI/BHMA A156.9.
- J. Adjustable Shelf Standards and Related Supports: Provide standards and supports of type indicated which comply with ANSI/BHMA A156.9.
  - 1. Vertical Slotted Type: Vertical slots spaced 2" on center, 7/8" wide x 11/16" high x length indicated, zinc plated steel. KV 87ANO Extra Heavy Duty Standards.
  - 2. Shelf Brackets: Size required to support shelving widths indicated, zinc-plated steel. KV187LL ANO Extra Heavy Duty Brackets.
- K. Grommets for Cable Passage through Countertops: 2-1/4-inch OD, black molded-plastic grommets and matching plastic caps with slot for wire passage.
  - 1. Product: Subject to compliance with requirements, provide "EDP" series" by Doug Mockett & Company, Inc.

## 2.3 INSTALLATION MATERIALS

- A. Furring, Blocking, Shims, and Hanging Strips: Softwood or hardwood lumber, kiln dried to less than 15 percent moisture content.
- B. Anchors: Select material, type, size, and finish required for each substrate for secure anchorage. Provide nonferrous-metal or hot-dip galvanized anchors and inserts on

inside face of exterior walls and elsewhere as required for corrosion resistance. Provide toothed-steel or lead expansion sleeves for drilled-in-place anchors.

- C. Adhesives, General: Do not use adhesives that contain urea formaldehyde.
- D. Adhesive for Bonding Plastic Laminate: Unpigmented contact cement.

## 2.4 FABRICATION, GENERAL

- A. Wood Moisture Content for Interior Woodwork: Comply with requirements of referenced quality standard for wood moisture content in relation to ambient relative humidity during fabrication and in installation areas.
- B. Sand fire-retardant-treated wood lightly to remove raised grain on exposed surfaces before fabrication.
- C. Fabricate woodwork to dimensions, profiles, and details indicated. Ease edges to radius indicated for the following:
  - 1. Ease edges to a 1/16" radius, for corners of cabinets and edges of solid wood (lumber) members less than 1" in nominal thickness, 1/8" radius for edges of rails and similar members over 1" in nominal thickness..
- D. Complete fabrication, including assembly, finishing, and hardware application, to maximum extent possible before shipment to project site. Disassemble components only as necessary for shipment and installation. Where necessary for fitting at site, provide ample allowance for scribing, trimming, and fitting.
- E. Shop cut openings, to maximum extent possible, to receive hardware, appliances, plumbing fixtures, electrical work, and similar items. Locate openings accurately and use templates or roughing-in diagrams to produce accurately sized and shaped openings. Sand edges of cutouts to remove splinters and burrs
  - 1. Seal edges of openings in countertops with a coat of varnish.
  - 2. Seal edges of openings in exterior applications with a water-resistant coating.

## 2.5 PLASTIC LAMINATE CABINETS

- A. Grade: Premium.
- B. AWI Type of Cabinet Construction: Flush overlay.
- C. Laminate Cladding for Exposed Surfaces: High-pressure decorative laminate complying with the following requirements:
  - 1. Horizontal Surfaces Other Than Tops: Grade HGS.
  - 2. Postformed Surfaces: Grade HGP.
  - 3. Vertical Surfaces: Grade VGS.
  - 4. Edges: PVC edge banding, 3mm thick, matching laminate in color, pattern, and finish.
- D. Materials for Semi-exposed Surfaces:

1. Surfaces Other Than Drawer Bodies: Thermoset decorative panels.
    - a. Edges of Plastic-Laminate Shelves: PVC edge banding, 0.12-inch thick, matching laminate in color, pattern, and finish.
    - b. For semi-exposed backs of panels with exposed plastic-laminate surfaces, provide surface of high-pressure decorative laminate, Grade VGS.
  2. Drawer Sides and Backs: Solid-hardwood lumber.
  3. Drawer Bottoms: Hardwood plywood
- E. Concealed Backs of Panels with Exposed Plastic Laminate Surfaces: High-pressure decorative laminate, Grade BKL.
1. Colors, Patterns, and Finishes: Match existing.
  2. Grade: Custom.
- F. High-Pressure Decorative Laminate Grade: HGS.
1. Colors, Patterns, and Finishes: Match existing.
- G. PVC Edges: Exposed countertop edging shall be 3mm PVC. The PVC shall be applied utilizing hot melt adhesive and radiused by automatic trimmers. Hand tool applying and trimming of PVC shall not be allowed.
- H. Core Material: Particleboard or medium-density fiberboard.
- I. Core Material at Sinks: Medium-density fiberboard made with exterior glue.
- J. Backer Sheet: Provide plastic-laminate backer sheet, Grade BKL, on underside of countertop substrate.
- K. Paper Backing: Provide paper backing on underside of countertop substrate.

## 2.6 SHOP FINISHING

- A. Grade: Provide finishes of same grades as items to be finished.
- B. General: Finish interior architectural woodwork at fabrication shop as specified in this section. Defer only final touchup, cleaning, and polishing until after installation.
- C. General: Shop finish transparent-finished interior architectural woodwork at fabrication shop as specified in this section.
- D. Shop Priming: Shop apply the prime coat including backpriming, if any, for transparent-finished items specified to be field finished.
- E. Preparations for Finishing: Comply with referenced quality standard for sanding, filling countersunk fasteners, sealing concealed surfaces, and similar preparations for finishing architectural woodwork, as applicable to each unit of work.
  1. Backpriming: Apply one (1) coat of sealer or primer, compatible with finish coats, to concealed surfaces of woodwork. Apply two (2) coats to surfaces installed in contact with concrete or masonry and to end-grain surfaces. Apply two (2) coats

to back of paneling and to end-grain surfaces. Concealed surfaces of plastic-laminate-clad woodwork do not require backpriming when surfaced with plastic laminate, backing paper, or thermoset decorative panels.

## PART 3 - EXECUTION

### 3.1 PREPARATION

- A. Before installation, condition woodwork to average prevailing humidity conditions in installation areas.
- B. Deliver concrete inserts and similar anchoring devices to be built into substrates well in advance of time substrates are to be built.
- C. Before installing architectural woodwork, examine shop-fabricated work for completion and complete work as required, including removal of packing and backpriming.

### 3.2 INSTALLATION

- A. Scribe and cut woodwork to fit adjoining work, refinish cut surfaces, and repair damaged finish at cuts.
- B. Anchor woodwork to anchors or blocking built in or directly attached to substrates. Secure to grounds, stripping and blocking with countersunk concealed fasteners and blind nailing as required for complete installation. Use fine finishing nails for exposed fastening, countersunk and filled flush with woodwork and matching final finish if transparent finish is indicated.
- C. Cabinets: Install without distortion so doors and drawers fit openings properly and are accurately aligned. Adjust hardware to center doors and drawers in openings and to provide unencumbered operation. Complete installation of hardware and accessory items as indicated.
  - 1. Install cabinets with no more than 1/8 inch in 96-inch sag, bow, or other variation from a straight line.
  - 2. Maintain veneer sequence matching of cabinets with transparent finish.
- D. Countertops: Anchor securely by screwing through corner blocks of base cabinets or other supports into underside of countertop.
  - 1. Align adjacent solid-surfacing-material countertops and form seams to comply with manufacturer's written recommendations using adhesive in color to match countertop. Carefully dress joints smooth, remove surface scratches, and clean entire surface.
  - 2. Install countertops with no more than 1/8 inch in 96-inch sag, bow, or other variation from a straight line.
  - 3. Secure backsplashes to tops with concealed metal brackets at 16 inches oc.
- E. Touch up finishing work specified in this section after installation of woodwork. Fill nail holes with matching filler where exposed.

### 3.3 ADJUSTING AND CLEANING

- A. Repair damaged and defective woodwork, where possible, to eliminate functional and visual defects; replace woodwork where not possible to repair. Adjust joinery for uniform appearance.
- B. Clean, lubricate, and adjust hardware.
- C. Clean woodwork on exposed and semiexposed surfaces. Touch up shop-applied finishes to restore damaged or soiled areas.

END OF SECTION



THIS PAGE INTENTIONALLY LEFT BLANK

## ROOF ACCESSORIES

## SECTION 07720

### PART 1 - GENERAL

#### 1.1 RELATED DOCUMENTS

- A. Drawings and general provisions of the Contract, including General and Supplementary Conditions and Division 1 specification sections, apply to this section.

#### 1.2 SECTION INCLUDES

- A. Equipment supports.

#### 1.3 PERFORMANCE REQUIREMENTS

- A. General Performance: Roof accessories shall withstand exposure to weather and resist thermally induced movement without failure, rattling, leaking, or fastener disengagement due to defective manufacture, fabrication, installation, or other defects in construction.

#### 1.4 SUBMITTALS

- A. Submit under provisions of Section 01300.
- B. Product Data: For each type of roof accessory indicated. Include construction details, material descriptions, dimensions of individual components and profiles, and finishes.

#### 1.5 COORDINATION

- A. Coordinate layout and installation of roof accessories with roofing membrane and base flashing and interfacing and adjoining construction to provide a leakproof, weathertight, secure, and noncorrosive installation.
- B. Coordinate dimensions with rough-in information or shop drawings of equipment to be supported.

### PART 2 - PRODUCTS

#### 2.1 METAL MATERIALS

- A. Zinc-Coated (Galvanized) Steel Sheet: ASTM A653, G90 coating designation and mill phosphatized for field painting where indicated.
  - 1. Mill-Phosphatized Finish: Manufacturer's standard for field painting.

## 2.2 MISCELLANEOUS MATERIALS

- A. General: Provide materials and types of fasteners, protective coatings, sealants, and other miscellaneous items required by manufacturer for a complete installation.
- B. Wood Nailers: Softwood lumber, pressure treated with waterborne preservatives for aboveground use, acceptable to authorities having jurisdiction, containing no arsenic or chromium, and complying with AWWA C2; not less than 1-1/2 inches thick.
- C. Underlayment:
  - 1. Felt: ASTM D226, Type II (No. 30), asphalt-saturated organic felt, non-perforated.
  - 2. Polyethylene Sheet: 6-mil thick polyethylene sheet complying with ASTM D4397.
- D. Fasteners: Roof accessory manufacturer's recommended fasteners suitable for application and metals being fastened. Match finish of exposed fasteners with finish of material being fastened. Provide non-removable fastener heads to exterior exposed fasteners. Furnish the following unless otherwise indicated:
  - 1. Fasteners for Zinc-Coated or Aluminum-Zinc Alloy-Coated Steel: Series 300 stainless steel or hot-dip zinc-coated steel according to ASTM A153 or ASTM F2329.
- E. Asphalt Roofing Cement: ASTM D4586, asbestos free, of consistency required for application.

## 2.3 EQUIPMENT SUPPORTS

- A. Equipment Supports: Internally reinforced metal equipment supports capable of supporting superimposed live and dead loads, including equipment loads and other construction indicated on Drawings; with welded or mechanically fastened and sealed corner joints, and integrally formed deck-mounting flange at perimeter bottom.
  - 1. Basis-of-Design Product: Subject to compliance with requirements, provide The Pate Company "Equipment Support es-5" or comparable product by one (1) of the following:
    - a. Curbs Plus, Inc.
    - b. LM Curbs.
    - c. Roof Products, Inc.
- B. Size: Coordinate dimensions with roughing-in information or shop drawings of equipment to be supported.
- C. Material: Zinc-coated (galvanized) thick.
  - 1. Finish: Mill phosphatized.
- D. Construction:
  - 1. Factory-installed continuous wood nailers 5-1/2 inches wide at tops of equipment supports.
  - 2. Metal Counterflashing: Manufacturer's standard, removable, fabricated of same metal and finish as equipment support.

3. On ribbed or fluted metal roofs, form deck-mounting flange at perimeter bottom to conform to roof profile.
4. Fabricate equipment supports to minimum height of 15 inches unless otherwise indicated.

## 2.4 GENERAL FINISH REQUIREMENTS

- A. Comply with NAAMM's "Metal Finishes Manual for Architectural and Metal Products" for recommendations for applying and designating finishes.
- B. Appearance of Finished Work: Noticeable variations in same piece are not acceptable. Variations in appearance of adjoining components are acceptable if they are within the range of approved samples and are assembled or installed to minimize contrast.

## PART 3 - EXECUTION

### 3.1 EXAMINATION

- A. Examine substrates, areas, and conditions, with installer present, to verify actual locations, dimensions, and other conditions affecting performance of the Work.
- B. Verify that substrate is sound, dry, smooth, clean, sloped for drainage, and securely anchored.
- C. Proceed with installation only after unsatisfactory conditions have been corrected.

### 3.2 INSTALLATION

- A. General: Install roof accessories according to manufacturer's written instructions.
  1. Install roof accessories level, plumb, true to line and elevation, and without warping, jogs in alignment, excessive oil canning, buckling, or tool marks.
  2. Anchor roof accessories securely in place so they are capable of resisting indicated loads.
  3. Use fasteners, separators, sealants, and other miscellaneous items as required to complete installation of roof accessories and fit them to substrates.
  4. Install roof accessories to resist exposure to weather without failing, rattling, leaking, or loosening of fasteners and seals.
- B. Metal Protection: Protect metals against galvanic action by separating dissimilar metals from contact with each other or with corrosive substrates by painting contact surfaces with bituminous coating or by other permanent separation as recommended by manufacturer.
  1. Underlayment: Where installing roof accessories directly on cementitious or wood substrates, install a course of felt underlayment and cover with a slip sheet, or install a course of polyethylene sheet.
  2. Bed flanges in thick coat of asphalt roofing cement where required by manufacturers of roof accessories for waterproof performance.

- C. Equipment Support Installation: Install equipment supports so top surfaces are level with each other.

### 3.3 REPAIR AND CLEANING

- A. Galvanized Surfaces: Clean field welds, bolted connections, and abraded areas and repair galvanizing according to ASTM A780.
- B. Touch up factory-primed surfaces with compatible primer ready for field painting according to Division 9 painting sections.
- C. Clean exposed surfaces according to manufacturer's written instructions.
- D. Replace roof accessories that have been damaged or that cannot be successfully repaired by finish touchup or similar minor repair procedures.

END OF SECTION

**PART 1 - GENERAL****1.1 DESCRIPTION**

- A. General: Provide wood doors and related work in accordance with the Contract Documents. All doors shall be installed in hollow metal frames.

**1.2 SECTION INCLUDES**

- A. Unrated solid particleboard core doors.
- B. Solid particleboard core doors with 20 minute fire rating.
- C. Factory finishing for wood veneer doors.

**1.3 RELATED SECTIONS**

- A. Section 06200 - Finish Carpentry.
- B. Section 08111 - Steel Frames.
- C. Section 08710 - Finish Hardware.
- D. Section 09900 - Paints and Coatings: Field finishing of wood doors.

**1.4 SUBMITTALS**

- A. Submit under provisions of Section 01300.
- B. Schedule of Doors: Show size, type, and details of construction and other pertinent data. Coordinate schedule with:
  - 1) Steel frame schedule and use frame numbers as set up by Section 08111.
  - 2) Hardware in Section 08710.
- C. Samples of Door Face:
  - 1) Wood Veneer: Provide face veneer samples representative of the range of color and grain of doors to be finished to the job. Veneer shall be within that range of color and grain as reviewed by the Architect and shall be stained if necessary to obtain desired color.
  - 2) Selected Sample: Submit sample of veneer chosen approximately 8-1/2 x 11 inches for final review before fabrication.
- D. Manufacturer's Literature: Include specifications, installation instructions and recommended methods of handling, finishing and maintenance to comply with these specifications and with warranty required.

## 1.5 QUALITY ASSURANCE

- A. Codes: Comply with State of Connecticut Building Code and listed standards.
- B. Standards:
  - 1) American National Standards Institute (ANSI).
  - 2) ASTM International (ASTM):
    - a) ASTM E90-97 - Method for Laboratory Measurement of Airborne - Sound Transmission Loss of Building Partition (for doors).
  - 3) Architectural Woodwork Institute (AWI): Architectural Woodwork Quality Standards Eight Edition, 2003 for architectural flush doors Section 01300 and Section 01500 factory finishing.
  - 4) Window and Door Manufacturers Association (WDMA):
    - a) Industry standard for flush doors WDMA I.S. 1-A-97.
  - 5) Underwriters Laboratories, Inc. (UL): Fire rated wood door standards.

## 1.6 DELIVERY, STORAGE AND HANDLING

- A. Deliver doors in manufacturer's fully identified containers coordinated with the frame and hardware schedule.
- B. Protect finishes from damage during the construction period with plastic wrap or other suitable device allowing the wood surface to breathe until acceptance. Store doors indoors away from high humidity sources.
- C. Comply with WDMA Storage and Handling requirements in Appendix.

## 1.7 WARRANTY

- A. Solid Core Doors: Submit manufacturer's life of original installation warranty for solid core wood doors. Include the removal, refinishing, re-glazing and re-hanging of the door. Warranty shall not cover doors vandalized, abused or used in a location or for a use not recommended if identified at the time of shop drawing submission.

## PART 2 - PRODUCTS

### 2.1 GENERAL FLUSH DOOR REQUIREMENTS

- A. Thickness of doors shall be 1-3/4 inch.
- B. Premium grade architectural doors shall have stiles and rails bonded by the hot press process to the core and sanded prior to the assembly of face veneers.
- C. Stile edges shall be of the same species as face veneer bonded to core 1-1/8 inch minimum after trim.

D. Doors shall be completely factory machined for hardware and lights.

## 2.2 UNRATED AND 20 MINUTE-RATED DOORS FOR OPAQUE FINISH

A. For general use as scheduled where fire ratings are not required.

1) Grade: Premium.

B. Manufacturer: Solid core particleboard door manufacturers shall be equal to:

- 1) Marshfield Doors - Timblend Core DPC-1 with additional wood blocking at large hardware cutouts.
- 2) Algoma Hardwoods Inc. - Novador (Super Novador at locations of large hardware cutouts).

C. Materials:

- 1) Faces: Any closed-grain hardwood of mill option.
- 2) Exposed Vertical Edges: Any closed-grain hardwood; minimum 1/4-inch thick.
- 3) Construction: Five (5) plies. Stiles and rails are bonded to core, then entire unit abrasive planed before veneering.
- 4) Cross-Bands: Kiln-dried hardwood 1/16-inch thick, extending full width of door, with grain at right angles to long dimension of doors.
- 5) Adhesive: Fully waterproof, Type I adhesive (hot press lamination).
- 6) Top and Bottom Rails: Minimum 1-3/8 inch hardwood or Structural Composite Lumber.
- 7) Core: Mat formed wood particleboard with density of 28-32 lbs per cu ft. Core shall comply with ANSI A208.1 Type 1-LD-2.
  - a) Where more than 40 percent of the door is cut out for lites or louvers use Structural Composite Lumber cores.

## 2.3 SOLID PARTICLEBOARD CORE DOORS WITH 20 MINUTE FIRE RATING

A. For general use at corridor as scheduled where 20 minute fire rating is required.

B. Manufacturer: Solid core particleboard door manufacturers shall be equal to:

- 1) Algoma Hardwoods Inc. - Novador (Super Novador at locations of large hardware cutouts).
- 2) Eggers Industries; Architectural Door Division.
- 3) Marshfield Doors - Timblend Core DPC-1 and additional wood blocking at large hardware cutouts.

C. Materials:

- 1) Wood Face Veneer shall be 1/32-inch minimum thickness before sanding for 5 ply, as per Article 2.1.
  - a) Premium Grade Plain Sliced Cherry.



- 2) Cross-Bands (for hardwood and high gloss plastic laminate only): Kiln-dried hardwood 1/16-inch thick, extending full width of door with grain at right angles to long dimension of doors.
- 3) Adhesive: Fully waterproof, Type I adhesive (hot press lamination).
- 4) Side Edges: Stiles shall be minimum 1-3/8 inch double laminate of hardwood with outer laminate to match the face veneer. Pairs shall have treated hardwood edges and transom bottom 1/2-inch thick minimum on stave.
- 5) Hinge Style Protection: Where scheduled at high traffic room doors provide high impact brown PVC flush edge protection with serrated legs and adhesive equal to Algoma Type 1F.
- 6) Top and Bottom Rails: These shall be minimum 1-3/8" hardwood with clear sealer.
- 7) Core: Shall be mat formed wood particleboard with density of 28-32 lbs per cu ft. Core shall comply with ANSI A208.1.

#### 2.4 FACTORY FINISHING FOR WOOD VENEER DOORS

- A. For use on natural finish wood doors scheduled to match hospital standard Cherry finish.
- B. Manufacturer: Factory finishes shall be equal to the following modified to AWI standards listed:
  - 1) Weyerhaeuser - Tigacled II.
  - 2) Algoma Hardwoods Inc. - 4 coat Univar.
- C. Materials:
  - 1) Transparent finish shall match adjacent architectural woodwork finish specified in Section 09900. Areas trimmed or marred in the field shall be refinished with the same factory supplied materials.
  - 2) Conform to AWI factory finishing standards meeting the requirements of System #3:
    - a) Transparent catalyzed conversion varnish finish.
    - b) Premium grade.
    - c) Dull rubbed sheen (16° - 24°).
    - d) Closed grain effect.
    - e) No effect on flame spread.
- D. Assembly: AWI Finish System #3 consists of:
  - 1) Wash coat.
  - 2) Stain (if needed).
  - 3) Filler. (Note: Filler and stain may be one application.)
  - 4) Sealer.
  - 5) Sanding (220 grit steared paper).

- 6) Top coat - 2 coats. (Note: To obtain a premium finish using Gardall it will be necessary to apply one coat of Gardall gloss coating followed by sanding followed by a final coat of Gardall Satin.)

E. Manufacturer shall be equal to Sherwin Williams:

- 1) Stain - S64 Series Wiping Stain.
- 2) Washcoat - T67F3 Vinyl Sealer 24 percent (Reduced 1:6).
- 3) Vinyl Sealer - T67F3 Vinyl Sealer 24 percent.
- 4) Filler - D70T1 Natural Filler.
- 5) Topcoat(s) - F63V1 Polane Clear Catalyzed with V66V29.

## 2.5 SHOP PRIMING

- A. Doors for Opaque Finish: Shop prime doors with one (1) coat of wood primer specified in Section 09900. Seal all four (4) edges, edges of cutouts, and mortises with primer.

## 2.6 FABRICATION

- A. Fabricate doors in sizes indicated for project site fitting.
- B. Factory fit doors to suit frame-opening sizes indicated, with the following uniform clearances and bevels, unless otherwise indicated:
  - 1) Comply with clearance requirements of referenced quality standard for fitting.
- C. Factory machine doors for hardware that is not surface applied. Locate hardware to comply with DHI-WDHS-3. Comply with final hardware schedules, door frame shop drawings, DHI A115-W series standards, and hardware templates.
  - 1) Coordinate measurements of hardware mortises in metal frames to verify dimensions and alignment before factory machining.

## PART 3 - EXECUTION

### 3.1 PREPARATION

- A. Coordination: Coordinate handling of wood doors with Section 08111 and Section 08710 so that wood doors are machined for hardware and fitted for the opening in the shop. The Installer has the option of doing this work in his own shop or having the door manufacturer provided the doors premachined and prefitted.
- B. Shop Fitting: Machine doors for hardware requiring cutting and rabbeting of doors. Factory prefit doors and undercut in accordance with the reviewed shop drawings.
  - 1) Edges: Bevel vertical edges 1/8-inch in two (2) inches.
  - 2) Clearances: Clearances for doors, except fire doors, shall be 1/8-inch at jambs and heads, 1/8-inch at meeting stiles of pairs of doors and 1/4-inch at bottom. Clearances for fire doors shall be as required by code.

3) Astragal:

- a) Provide astragal for double doors to match face veneer of doors (where doors are not rabbeted).

### 3.2 INSTALLATION

- A. Drawings and Schedules: Install wood doors in designations shown on the drawings, and fit with finish hardware in accordance with the drawings, reviewed hardware schedule and as specified.
- B. Hardware Installation: Hardware shall be installed by skilled mechanics, in the sinkages, cutouts and routes provided in doors and frames, and other locations for a complete installation. Give special attention to installation of overhead door holders, for proper operation. Securely adhere armor plates, to doors where indicated. Do not cut or plane hinge stile. Return door panel to manufacturer for size adjustments.
- C. Door Installation: When hanging wood doors, do not force hinge leaves against routed edges. Wood screws shall be uniformly set to have full shank sheet metal threads and to be set into drilled pilots holes. Doors shall be plumb and in perfect operating condition.
- D. Adjustments: At completion of the job, examine, test oil, ease and otherwise adjust hardware for perfect and silent operation. The material shall be carefully handled and be free of scratches, dents, discolorations, tool marks, or other defacement at completion. Keep knobs and handles covered until completion of the painting work.
- E. Touch Up: Doors shall have trimmed areas sealed and finished to match factory finishing. Finished doors shall have scratches, dents, and blemishes repaired.

### 3.3 PROTECTION

- A. Protect wood doors from damage during the construction period until acceptance.

END OF SECTION

**PART 1 - GENERAL****1.1 RELATED DOCUMENTS**

- A. Drawings and general provisions of the Contract, including General and Supplementary Conditions and Division 1 Specification Sections, apply to this Section.

**1.2 SECTION INCLUDES**

- A. Acoustical panel lay-in ceiling assemblies as shown and scheduled.

**1.3 RELATED SECTIONS**

- A. Section 09250 – Gypsum Board: Suspended gypsum drywall ceiling assemblies.

**1.4 SUBMITTALS**

- A. Submit under provisions of Section 01300.
- B. Product Data: For all material included in the work.
- C. Product Certification Form: For ceiling panels and suspension systems.

**1.5 SEISMIC RESTRAINT**

- A. Provide seismic restraint for suspended ceilings, in accordance with the requirements of International Building Code (IBC)/2006 and ASTM E580, Standard Practice for Application of Ceiling Suspension Systems for Acoustical Tile and Lay-in Panels in Areas Requiring Seismic Restraint, and as indicated on the Drawings.

**1.6 QUALITY ASSURANCE**

- A. Provide acoustical ceilings that are identical to those tested for the following fire-performance characteristics, per ASTM test method indicated below, by UL or other testing and inspecting organizations acceptable to authorities having jurisdiction. Identifying acoustical ceiling components with appropriate markings of applicable testing and inspecting organization.
  - 1) Surface Burning Characteristics: as follows, tested per ASTM E84 and complying with ASTM E1264 for Class A products:
  - 2) Flame Spread: 25 or less.
  - 3) Smoke Developed: 50 or less.
- B. Manufacturer: Specializing in the manufacture of acoustical ceiling systems with five (5) years minimum experience.
- C. Installer: Specializing in the installation of acoustical ceiling systems with three (3) years minimum experience.

## 1.7 DELIVERY, STORAGE AND HANDLING

- A. Deliver acoustical ceiling units to project site in original, unopened packages and store them in a fully enclosed space where they will be protected against damage from moisture, direct sunlight, surface contamination, and other causes.
- B. Before installing acoustical ceiling units, permit them to reach room temperature and a stabilized moisture content.
- C. Handle acoustical ceiling units carefully to avoid chipping edges or damaging units in any way.
- D. Do not install interior acoustical ceilings until space is enclosed and weatherproof, wet-work in space is completed and nominally dry, work above ceilings is complete, and ambient conditions of temperature and humidity will be continuously maintained at values near those indicated for final occupancy.

## 1.8 PROJECT CONDITIONS

- A. Maintain uniform temperature of minimum 60 degrees F, and humidity of 20 to 40 percent prior to, during, and after installation.

## 1.9 ADDITIONAL MATERIALS

- A. At completion of work, deliver an extra two (2) percent acoustical ceiling material of each type installed, in addition to all unused material ordered for project, to Owner for use in making future repairs.

## PART 2 - PRODUCTS

### 2.1 MANUFACTURERS

- A. In other Part 2 articles where titles below introduce products, the following requirements apply for product selection:
  - 1) Basis-of-Design Manufacturer/Product: The design for each acoustical ceiling material type is based on the products of Armstrong World Industries. Subject to compliance with requirements, provide either the name manufacturer and product or a manufacturer and product deemed comparable by the Architect.

### 2.2 ACOUSTICAL CEILING PANELS

- A. Acoustical Ceiling Tile Type ACT-1: Match existing.
- B. Acoustical Ceiling Tile Type ACT-2: Match existing.

### 2.3 EXPOSED GRID SUSPENSION SYSTEM FOR ACOUSTICAL TILE

- A. Exposed Grid System Type ACT-1, ACT-2: Match existing.
  - 1) Main and Cross Tees: Hot dipped galvanized steel with bottom flange wrapped in enameled steel. Tees and hangers designed to support all loads, including fixtures. Deflection of tees not to exceed 1/360 span.

- 2) Special Trim Details: Wall moldings, radiused wall moldings, corner caps and other accessory items required. Wall moldings and corner caps shall have hemmed edges.
  - 3) Hold Down Clips: Extruded polyvinyl chloride clip.
  - 4) Attachment Devices: Size for five (5) times design load indicated in ASTM C635, Table I, Direct Hung, unless indicated otherwise. Comply with seismic design requirements.
    - a) Anchors in Concrete: Anchors of type and material indicated below, with holes or loops for attaching hangers of type indicated and with capability to sustain, without failure, a load equal to five (5) times that imposed by ceiling construction, as determined by testing per ASTM E488 or ASTM E1512 as applicable, conducted by a qualified testing and inspecting agency.
      1. Type: Post-installed expansion anchors.
      2. Corrosion Protection: Components fabricated from nickel-copper-alloy rods complying with ASTM B164 for UNS No. N04400 alloy.
  - 5) Finish: Lightly textured white polyvinyl chloride; match color of acoustical ceiling tile.
- B. Wire Hangers, Braces, and Ties: Provide wires complying with the following requirements:
- 1) Nickel-Copper-Alloy Wire: ASTM B164, nickel-copper-alloy UNS No. N04400.
  - 2) Size: Select wire diameter so its stress at three (3) times hanger design load (ASTM C635, Table 1, "Direct Hung") will be less than yield stress of wire, but provide not less than 12-gage wire.

## PART 3 - EXECUTION

### 3.1 EXAMINATION

- A. Examine substrates and structural framing to which ceiling system attaches or abuts, with Installer present, for compliance with requirements specified in this and other sections that affect installation and anchorage of ceiling system. Do not proceed with installation until unsatisfactory conditions have been corrected.

### 3.2 INSTALLATION

- A. Install work in accordance with "Ceiling Systems Handbook" published by the Ceilings and Interior Systems Construction Association (CISCA) and ASTM E580.
- B. Install ceilings with finished surfaces at heights indicated. Provide fastenings, inserts, anchors, clamps, and all other devices needed for complete installations.
- C. Install ceiling acoustical materials without soiling or damaging. Make any required cuts neatly and so that the cut piece fits accurately into the support grillage. Field cut rabbets at border and other small units of rabbeted edge board ceilings to match rabbets of field units. Paint field cut exposed edges of rabbeted edge ceiling board to match faces.
- D. Furnish and erect all additional channels and other materials required for support of lighting fixtures and other items occurring in ceilings; set to the exact requirements of these items. Coordinate this work with that of other trades whose work penetrates or attaches to acoustically treated surfaces.

- 1) Install units in patterns shown with all edges in true alignment. Scribe units to neatly fit abutting surfaces.
- E. Furnish and install color-coded identifying buttons on acoustic panels at locations of concealed valves, dampers, and switches.
- F. Make acoustical ceiling grid true, straight, plumb and level before proceeding with the acoustical ceiling panel installation. Provide additional wires as required to properly position grid. Double wires at support of light fixtures and heating and ventilating units.
- G. Install corner caps at all ceiling suspension system and bullnose block intersections in accordance with manufacturers recommended practices. Color: Match ceiling suspension system.
- H. Coordinate installation with locations of light fixtures.
- I. Install all integral ceiling diffusers. Refer to HVAC Drawings.
- J. Expansion/contraction provisions: in accordance with manufacturer's recommendations.

### 3.3 ADJUSTING AND CLEANING

- A. Replace damaged and broken panels.
- B. Clean exposed surfaces of acoustical ceilings, including trim, edge moldings, and suspension members. Comply with manufacturer's instructions for cleaning and touch-up of minor finish damage. Remove and replace work that cannot be successfully cleaned and repaired to permanently eliminate evidence of damage.

END OF SECTION

# SCOPE CLARIFICATION

## NOTES:

- 1 SERIBS IS RESPONSIBLE FOR DELIVERY OF CT GANTRY, CT TABLE, PEGS WORK STATION AND EQUIPMENT THIS WILL OCCUR THREE (3) WEEKS BEFORE THE START OF THE PROJECT. THE CT GANTRY, CT TABLE, CONSOLE, PEGS CABINET AND TOWER WILL BE DELIVERED TO THE SITE AND WILL BE BOULDED TO THE CT GANTRY, CT TABLE, PEGS, PEGS CABINET AND HEAT EXCHANGER. CONTRACTOR IS TO SECURE THE LIBERT UNIT.
- 2 SERIBS WILL INSTALL AND REMOVE OLD CT GANTRY, TABLE POWER DISTRIBUTION CABINET, ASSOCIATED CONTROL EQUIPMENT AND SUPPORTS. ALL OLD EQUIPMENT SHOULD BE REMOVED BEFORE THE NEW EQUIPMENT ARRIVES.
- 3 CONTRACTOR TO PATCH HOLES LEFT BY OLD CT MACHINE PRIOR NEW CT SCAN INSTALLATION. CONTRACTOR AND OWNER TO COORDINATE WITH SERIBS TO SCHEDULE EQUIPMENT REMOVAL. PROVIDE 3-4 WEEKS NOTICE EQUIPMENT ARRIVES.
- 4 CONTRACTOR TO REMOVE OLD NECTOR, MODIFY AND PREPARE STRUCTURE TO RECEIVE NEW SERIBS MED RAD NECTOR. CONTRACTOR TO BRIDGE REQUIRED CONDUIT BACK TO CONTROL ROOM IS IN PLACE. REFER TO MEP AND SERIBS DRAWINGS.
- 5 SERIBS INSTALL TEAM WILL PAIR AN EXIST' EXEILING PAD IN THE AREA BELOW THE CT SCANNER GANTRY AND TABLE FOOTPRINT. MATERIALS REQUIRED TO BOULD DOWN GANTRY, TABLE, PEGS AND PEGS WILL BE APPLIED AND COMPLETED BY SERIBS (PER SERIBS DRAWINGS).
- 6 SERIBS WILL PROVIDE NEW HEAT EXCHANGER CABINET (INDOOR UNIT) AND ROOF MOUNTED CONDENSER (OUTDOOR UNIT) THREE WEEKS PRIOR TO THE START OF THE PROJECT. SERIBS WILL PROVIDE THE HEAT EXCHANGER CABINET (INDOOR UNIT) WILL BE BOULDED TO STRUCTURE BY SERIBS.
- 7 CONTRACTOR TO RECEIVE STORE AND INSTALL NEW UPS AND UPS BATTERIES. CONTRACTOR IS TO COORDINATE DELIVERY WITH SERIBS AND OWNER. BRIDGE TO OBTAIN AND INSTALL HARDWARE TRHEET (3) WEEKS PRIOR TO DELIVERY OF CT EQUIPMENT TO BE PROVIDED BY SERIBS.
- 8 CT SCAN CONTROL ROOM REQUIRES A DATA ROOM (BY CONTRACTOR) UNDER CONTROL DESK, BOX AND CONTROL). SERIBS JPMCC CENTER TO COORDINATE WITH ICOMN IT DEPARTMENT FOR VPN TUNNEL OPTION WITH IP ADDRESSES ESTABLISHED BY ICOMN IT DEPARTMENT.
- 9 CONTRACTOR TO BRIDGE EXISTING X-RAY TUNNEL ALONG WITH POWER VOLTAGE AND SWITCHING ARE IN ACCORDANCE TO SERIBS DRAWING SPECIFICATIONS.
- 10 POWER TESTING IS NOT REQUIRED PER SERIBS DIRECTIVE JANUARY 04, 2004
- 11 CONTRACTOR WILL RECEIVE STORE AND INSTALL NEW MED RAD STEEL ANT DIAL, HEAD CEILING MOUNTED NECTOR. COORDINATE DELIVERY WITH SERIBS AND OWNER.
- 12 WHERE THE TERMS 'CUSTOMER/OWNER/CONTRACTOR' ARE USED IN SERIBS DRAWINGS TO INDICATE REQUIRED WORK, THIS SHALL BE CONDUCTED BY CONTRACTOR.

NOTE - CONTRACTOR WILL COORDINATE ALL DELIVERIES OF MATERIALS WITH OWNERS REPRESENTATIVE. CONTRACTOR MAY NOT DISTURB HOSPITAL FUNCTIONS. ASSUME PORTIONS OF THIS EFFORT WILL OCCUR IN PREMIUM TIME/OFF PEAK HOURS.

APPROXIMATE LOCATION OF EXISTING CT SCAN ROOFTOP CONDENSING UNIT. CONTRACTOR TO REMOVE UNIT AND ASSOCIATED WOOD CRIBBING. INSTALL NEW ROOFTOP CONDENSING UNIT TO SUPPORT NEW CT SCANNER (HEAT EXCHANGER) IN SAME LOCATION.

AREA H  
JOHN DEMPSEY  
HOSPITAL (JDH)

CONTRACTOR TO COORDINATE WORK RELATED TO PROJECT. REFER TO ARCHITECTURAL, MEP AND SERIBS DRAWINGS FOR WORK RELATED AT MAIN FLOOR LEVEL, ROOF, GROUND BASEMENT AND SUB-BASEMENT.

BUILDING  
MRI

OUTLINE OF CT SCAN ABOVE. CONTRACTOR TO COORDINATE PROJECT RELATED WORK WITH OWNER ABOVE. CEILING WORK WILL BE REQUIRED. ROOMS H001-H004 HAVE AGI CEILING AND ROOMS LG073 AND LG074 HAVE HARD CEILING. CAREFULLY RESTORE DISTURBED CONDUIT REQUIRED WORK AND RESTORE DISTURBED CEILING TO ORIGINAL CONDITION.

## 2 PARTIAL GROUND FLOOR PLAN

SCALE: 1/8" = 1'-0"

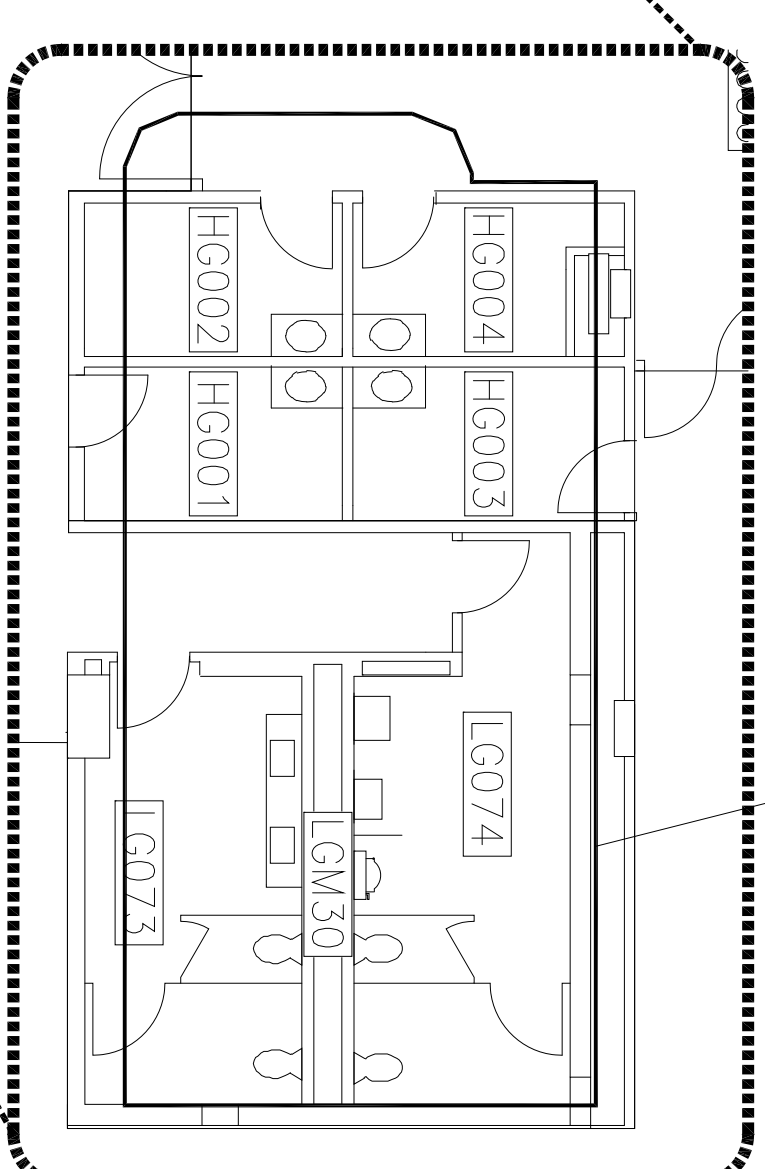

AREA F  
HOSPITAL SUPPORT  
BUILDING (HSB)

AREA WHERE NEW ROOF TOP CONDENSOR SUPPORTING LIBERT UNIT IS TO BE PLACED. REFER TO MEP DRAWINGS FOR LOCATION.

POSSIBLE "AT GRADE" LOCATION FOR RIGGING OF MECHANICAL EQUIPMENT TO AND FROM ROOFTOP. CONTRACTOR IS TO CONFIRM AND MAKE COORDINATION FOR FINAL RIGGING SOLUTION.

CONTRACTOR TO MINIMIZE DISTURBANCE TO ALL EXISTING CEILING AND SYSTEMS WHILE EXECUTING WORK AND CONSTRUCTION OF PROJECT SYSTEMS. REMOVE, RE-USE AND RE-INSTALL ALL SYSTEM MATERIALS, REPLACE DAMAGED MATERIALS IN KIND TO MATCH EXISTING.

CONTRACTOR TO COORDINATE AND PERFORM REQUIRED WORK TO CONNECT PROJECT COMPONENTS IN THIS AREA AT THE ROOF AND THE CT SUITE EQUIPMENT CLOSETS AND OTHER REQUIRED AREAS. COORDINATE ALL SCHEDULING WITH OWNER. CONTRACTOR TO ANTICIPATE PERFORMING WORK ON PREMIUM TIME/OFF-PEAK HOURS. PROVIDE/PERFORM WORK PER UCHC REGULATIONS AND CONTAINMENT REQUIREMENTS.

CONTRACTOR COORDINATION REQUIRED BELOW ON GROUND FLOOR WITH OWNER IN ORDER TO MINIMIZE DISRUPTION TO HOSPITAL FUNCTIONS. ANTICIPATE PERFORMING WORK ON PREMIUM TIME. PROVIDE/PERFORM WORK PER UCHC REGULATIONS AND CONTAINMENT REQUIREMENTS. VERIFY CONDITIONS - NOTE AT FLOOR BELOW THERE ARE OFFICES AND TOILET ROOMS WITH COMBINATION OF SUSPENDED AND HARD CEILING.

## 1 OVERALL SCOPE PLAN

SCALE: 1/8" = 1'-0"

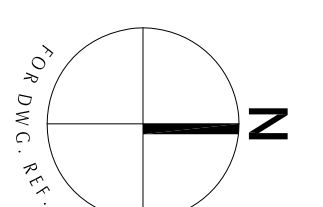
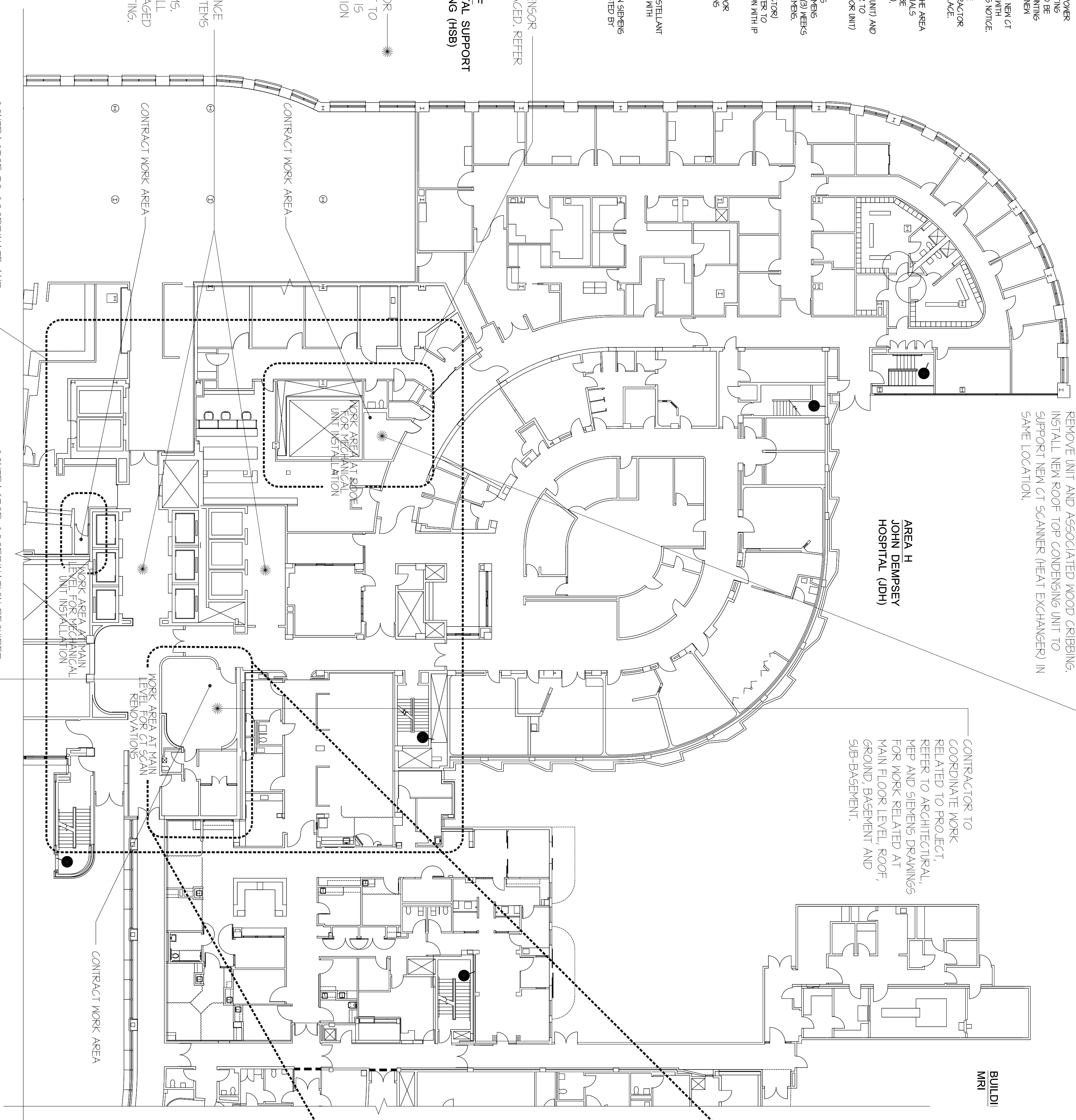

This drawing and details only, as an instrument of service, is the property of Fletcher Thompson and may be used for this specific project and shall not be reproduced or transmitted in any form or by any means, electronic, mechanical, photocopying, recording, or by any information storage and retrieval system, without the prior written consent of Fletcher Thompson.

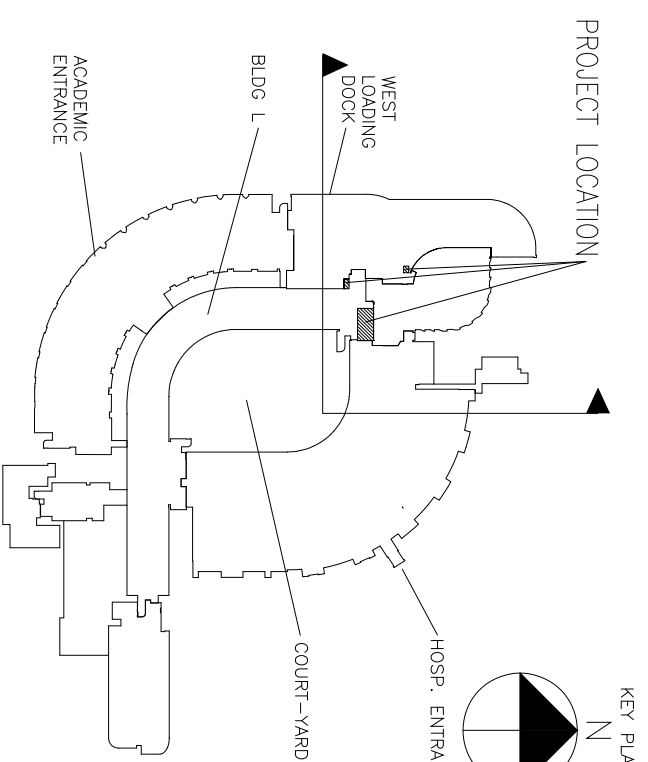

PROFESSIONAL SEAL

PROJECT MANAGER: VN  
ARCHITECT/DESIGNER: HH  
ENGINEER/DESIGNER: HH  
DRAWN BY: HHH

FLETCHER THOMPSON  
ARCHITECTURE / ENGINEERING / INTERIOR DESIGN

SHELTON, CONNECTICUT  
203-225-6500  
HARTFORD, CONNECTICUT  
860-249-0888  
SOMERSET, NEW JERSEY  
732-907-6800  
NEW YORK, NEW YORK  
212-695-4767  
NAPLES, FLORIDA  
239-687-1220

UConn Health Center  
Replacement  
CT Scanner

263 Farmington Avenue  
Farmington, CT  
UCHC Project no. 08-050

OVERALL SCOPE PLAN  
AND NOTES

PROJECT TITLE: UCHC Project no. 08-050

DATE: December 12, 2008

SCALE: 1/8" = 1'-0"

PROJECT NO.: H080380

DRAWING NO.: A001









This drawing and details are the intellectual property of Fletcher Thompson and may be used for this specific project and shall not be copied, reproduced or otherwise used without written consent of Fletcher Thompson.

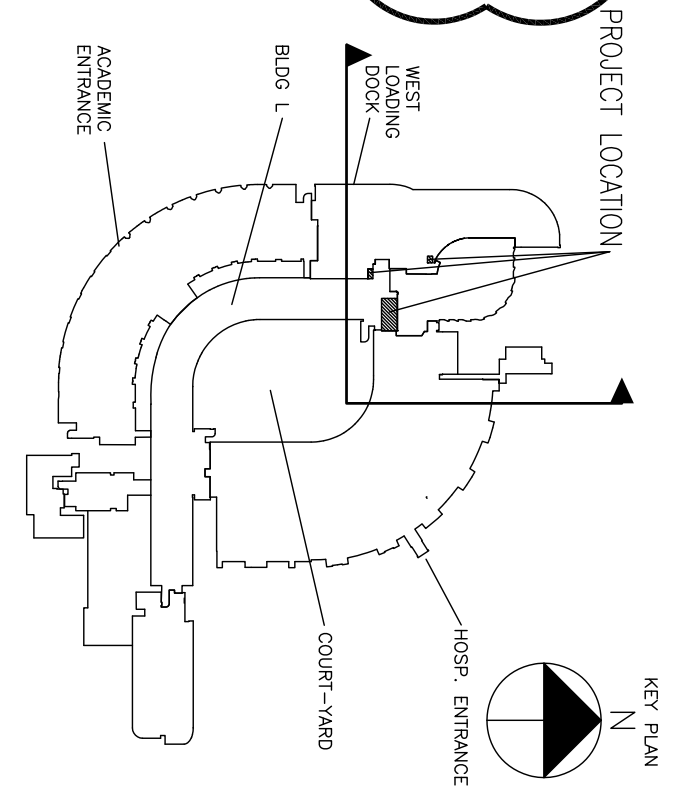

PROFESSIONAL SEAL

PROJECT MANAGER: VN  
 ARCHITECT/DESIGNER: HH  
 ENGINEER/DESIGNER: HH  
 DRAWN BY: HPH



ARCHITECTURE/ENGINEERING/INTERIOR DESIGN  
**FLETCHER THOMPSON**  
 SHELLTON, CONNECTICUT  
 203-223-6500  
 HARTFORD, CONNECTICUT  
 860-249-0888  
 SOMERSET, NEW JERSEY  
 732-907-6800  
 NEW YORK, NEW YORK  
 212-693-4767  
 NAPLES, FLORIDA  
 239-687-1220

**UConn Health Center  
 Replacement  
 CT Scanner**

263 Farmington Avenue  
 Farmington, CT  
 UCHC Project no. 08-050

DRAWING TITLE  
**INTERIOR ELEVATIONS  
 AND SECTIONS**

NO. 1  
 DATE: 01-13-04  
 REVISION: APPENDIX NO. 1  
 BY: \_\_\_\_\_

DATE: December 12, 2008

PROJECT NO.: H080380  
 DRAWING NO.: A101

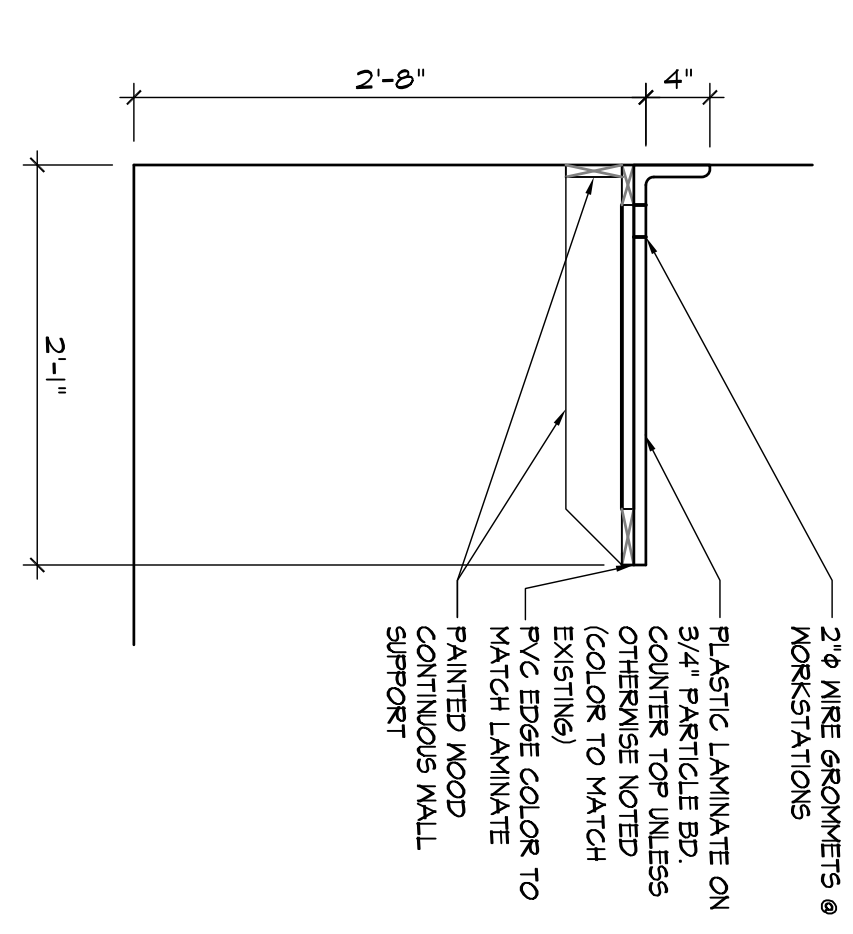
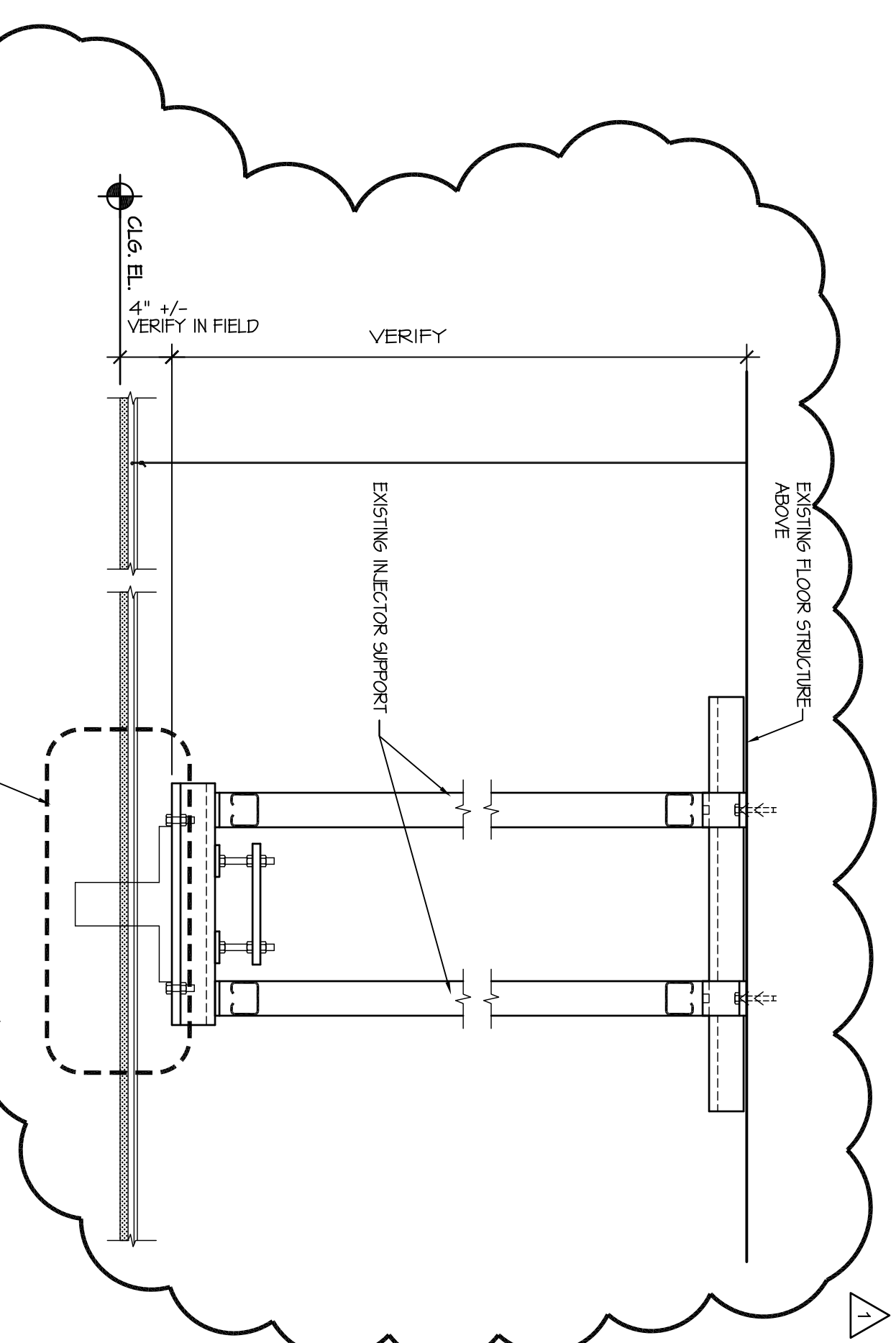
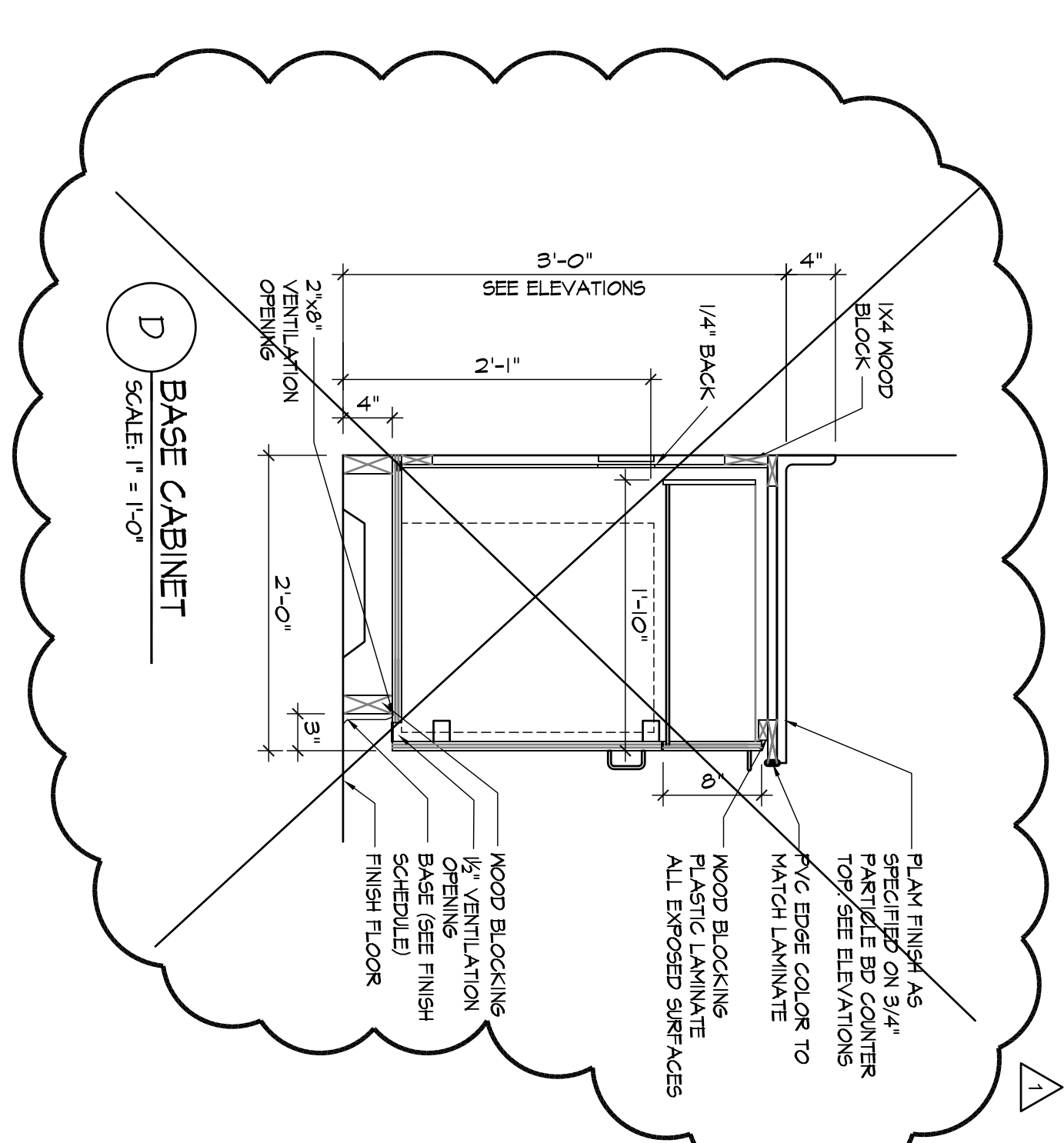

DOOR SCHEDULE				
DOOR NUMBER	FRAME SIZE	DOOR MATERIAL	DOOR FRAME	NOTES
02	4'-0"x7'0"	WD	HM	EACH LEAF 2'-0" WIDE
10	6'-0"x7'0"	WD	HM	EACH LEAF 3'-0" WIDE
				HW SET 01

HW SET: 01 (EQUIPMENT ROOM PAIR)

QTY.	ITEM	M/DL #	FIN.	MFR.
6 EA	HINGE	58B1 NRP	652	IVE
2 EA	MANUAL FLUSH BOLT	FB448	626	IVE
1 EA	CLASSROOM LOCK	10 - 10G37 PL	626	SAR
1 SET	ASTRAGAL	137NA	AL	NGP
2 EA	OVERHEAD STOP	450S	652	GLY
1 SET	SEALS	134NA	AL	NGP
2 EA	DOOR BOTTOM	422N	AL	NGP

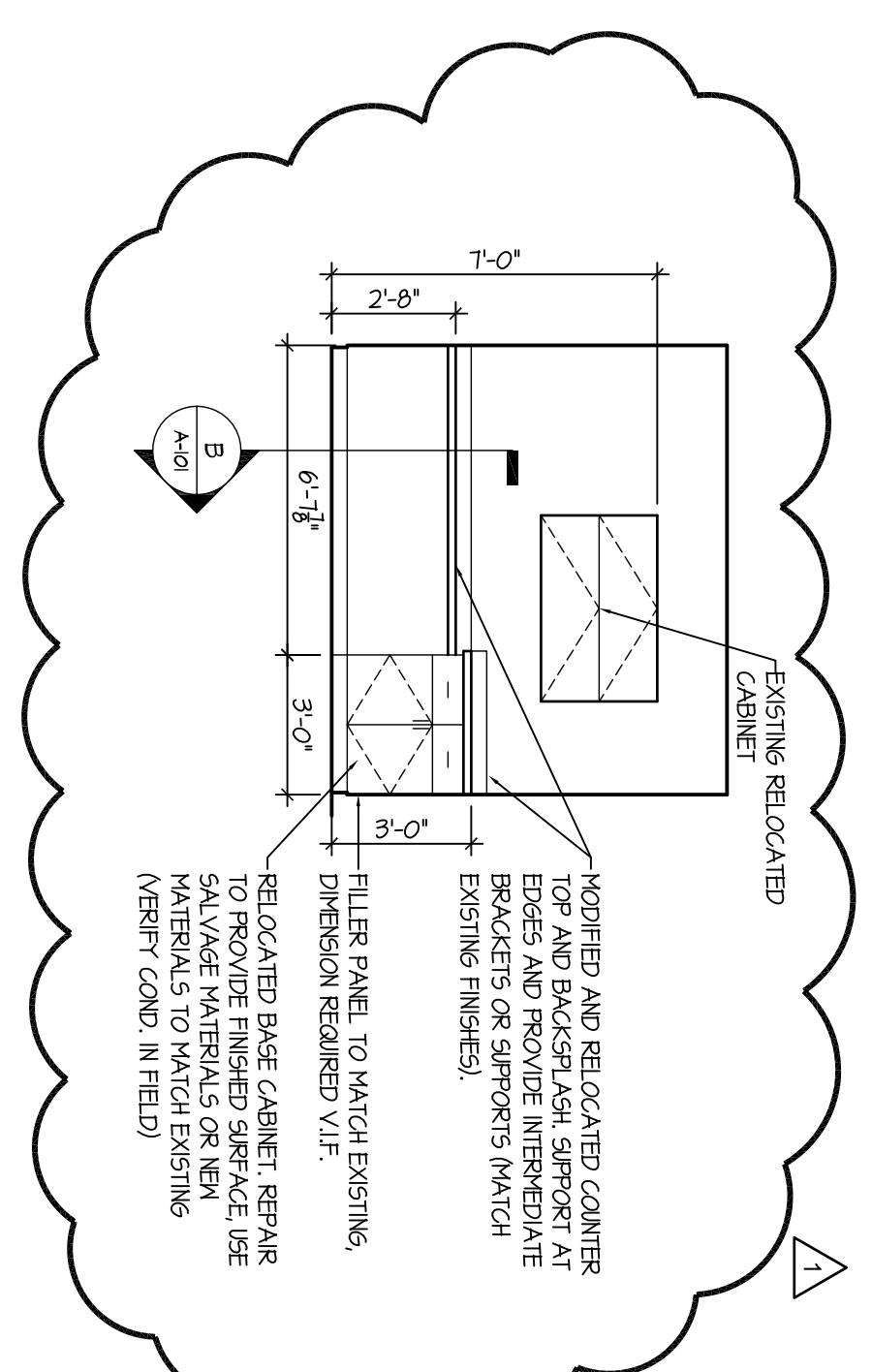
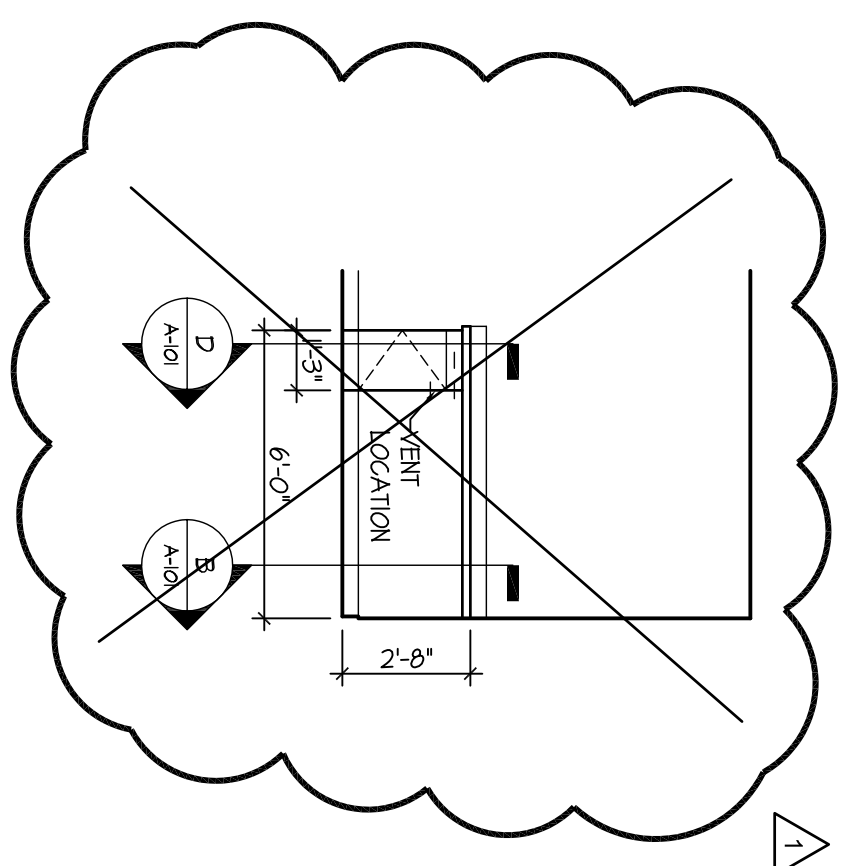

3 HARDWARE SET #1

2 INTERIOR ELEVATION READING ROOM

1 INTERIOR ELEVATION CONTROL ROOM

This drawing and details only, as an instrument of service, is the property of Fletcher Thompson and may be used for this specific project and shall not be reproduced, stored in a retrieval system, or transmitted in any form or by any means, without the consent of Fletcher Thompson.

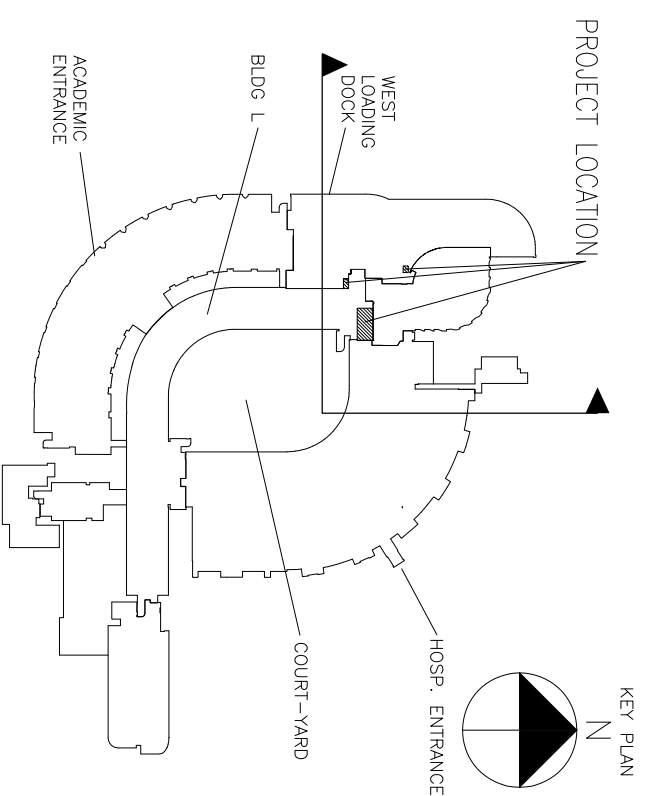

PROFESSIONAL SEAL	
PROJECT MANAGER	VN
ARCHITECT/DESIGNER	HH
ENGINEER/DESIGNER	HHH
DRAWN BY	HHH

**FLETCHER THOMPSON**  
ARCHITECTURE/ENGINEERING/INTERIOR DESIGN

SHELTON, CONNECTICUT  
203-223-6500  
HARTFORD, CONNECTICUT  
860-249-0888  
SOMERSET, NEW JERSEY  
732-907-6800  
NEW YORK, NEW YORK  
212-695-1767  
NAPLES, FLORIDA  
239-687-1220

**UConn Health Center  
Replacement  
CT Scanner**

263 Farmington Avenue  
Farmington, CT  
UCHC Project no. 08-050

**PARTIAL ROOF  
FRAMING PLAN  
AND DETAILS**

DRAWING TITLE  
PROJECT NO. H080380  
DATE December 12, 2008  
SCALE  
DRAWING NO. A110

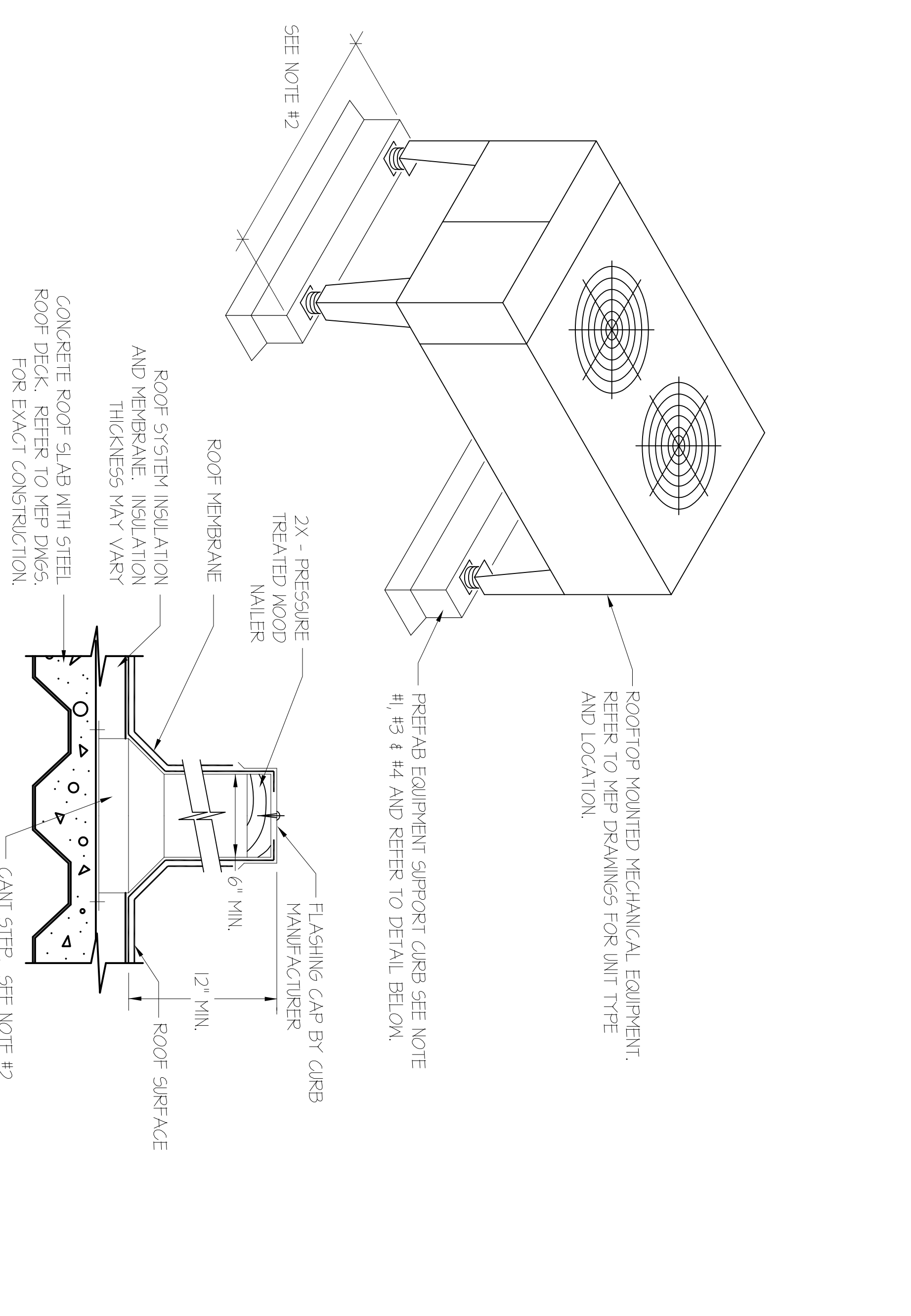
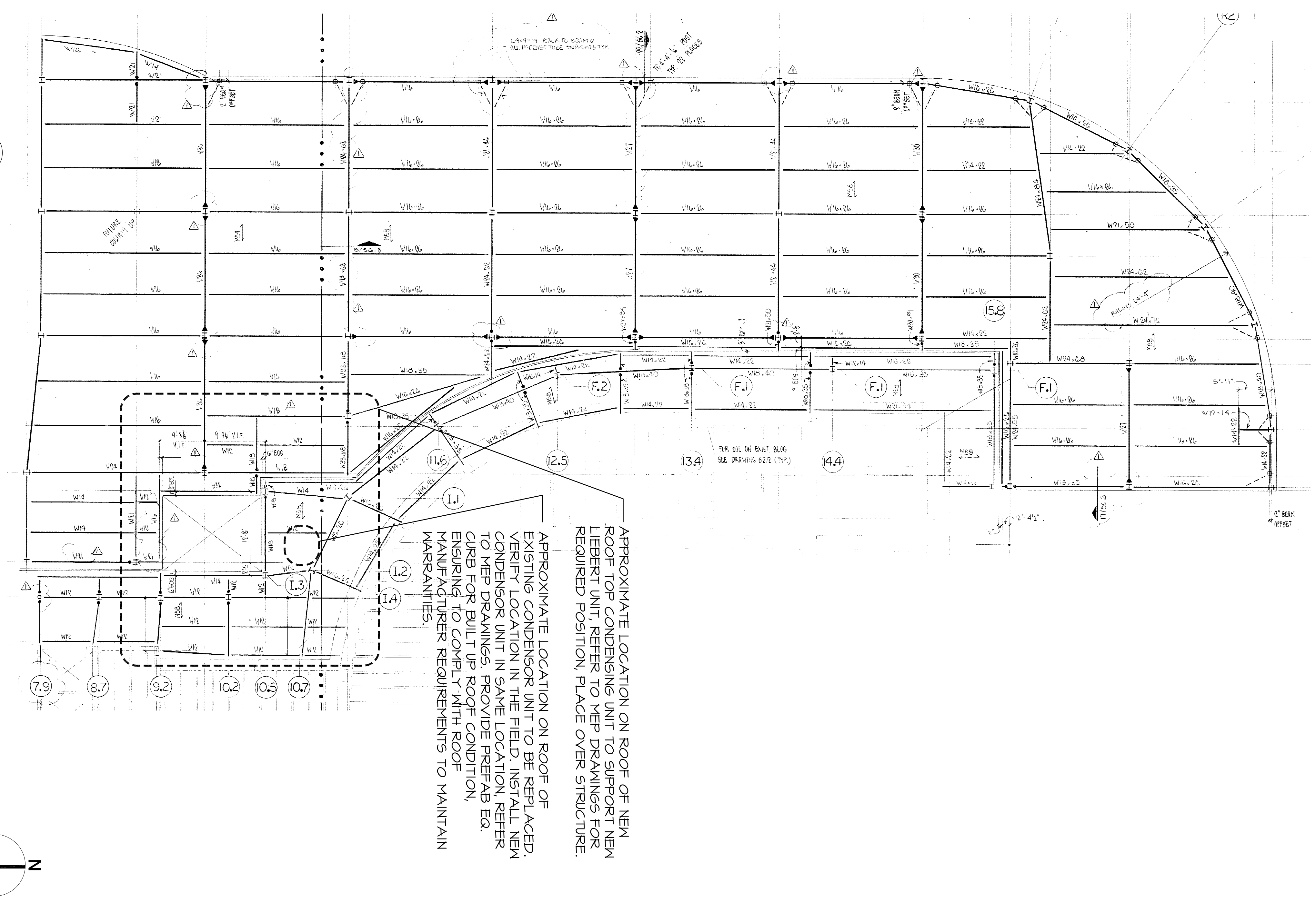

- NOTES:
1. REFER TO MECHANICAL EQUIPMENT MANUFACTURERS INSTALLATION INSTRUCTIONS FOR EXACT LOCATION OF MOUNTING DIMENSIONS FOR CURB INSTALLATION.
  2. MECHANICAL CONTRACTOR SHALL COORDINATE EXACT REQUIREMENTS FOR LENGTH AND WIDTH IN STRICT ACCORDANCE WITH EQUIPMENT MANUFACTURER. THE CANT STEP HEIGHT SHALL BE COORDINATED WITH ARCH. DWGS. AND MANUFACTURER.
  3. EQUIPMENT RAILS SHALL BE PRE-FABRICATED WITH BUILT-IN CANT. MONOLITHIC CONSTRUCTION WITH INTEGRAL BASE PLATE AND CONTINUOUS MITERED AND WELDED CORNER SEAMS. WITH FACTORY INSTALLED STEEL COUNTER FLASHING CAP WITH INTEGRAL DRIP EDGE. ALL CORNERS MITERED AND WELDED AND SCREWS FOR ATTACHMENT. EQUIPMENT RAILS OVER 3 FEET LONG SHALL INCORPORATE 1/4 GAUGE INTERNAL GUSSET REINFORCING. SECURELY FASTEN TO ROOF DECK AND INSTALL IN STRICT ACCORDANCE WITH MANUFACTURERS INSTALLATION INSTRUCTIONS.
  4. MECHANICAL CONTRACTOR SHALL PROVIDE SEISMIC RESTRAINTS AS REQUIRED IN STRICT ACCORDANCE WITH THE APPLICABLE BUILDING CODES AND THE CONTRACT DOCUMENTS.

**3 ROOF MOUNTED MECHANICAL SUPPORT**  
NOT TO SCALE

PATCH AND REPAIR ROOFING TO INSTALL NEW EQUIPMENT AND ALL PENETRATIONS TO MAINTAIN ROOF WARRANTY. ALSO ENSURE TO PLACE NEW ROOF TOP EQUIPMENT & CURB OVER ROOF STRUCTURE.

**2 PITCH POCKET DETAIL**  
SCALE: 1 1/2" = 1'-0"

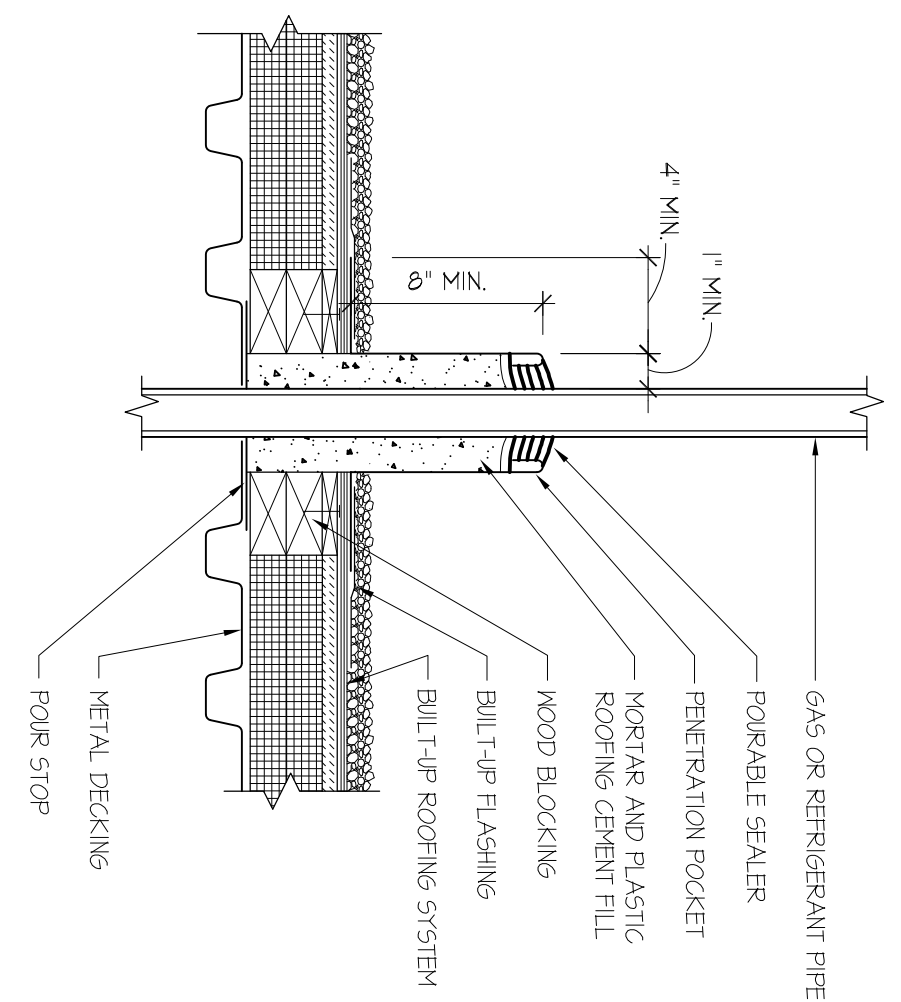

PATCH AND REPAIR ROOFING TO INSTALL NEW EQUIPMENT AND ALL PENETRATIONS TO MAINTAIN ROOF WARRANTY. ALSO ENSURE TO PLACE NEW ROOF TOP EQUIPMENT & CURB OVER ROOF STRUCTURE.

**1 PARTIAL ROOF FRAMING PLAN**  
NOT TO SCALE

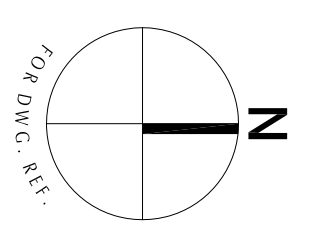



This drawing and details on it, as an instrument of service, is the property of Fletcher Thompson and may be used for this specific project and shall not be used for any other project without the written consent of Fletcher Thompson.

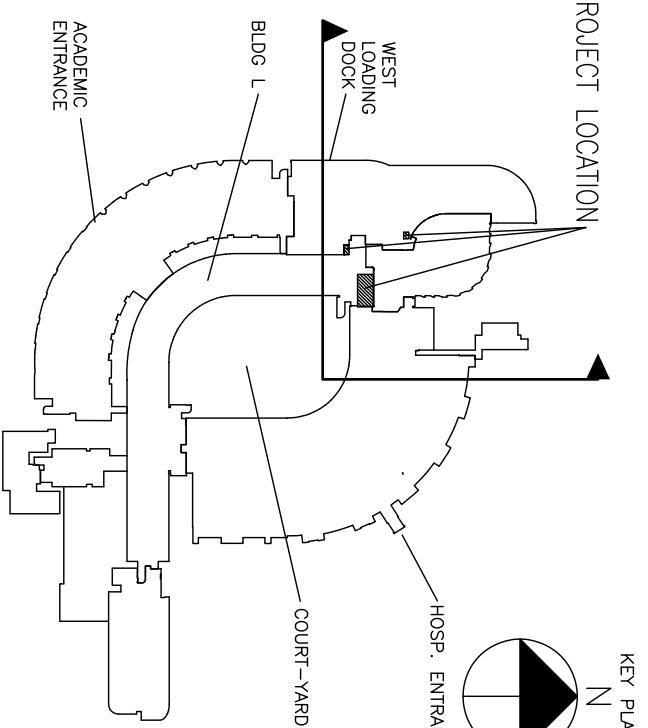

PROFESSIONAL SEAL

PROJECT MANAGER: VN  
 ARCHITECT/DESIGNER: HH  
 ENGINEER/DESIGNER: HH  
 DRAWING BY: HH

**FLETCHER THOMPSON**  
 ARCHITECTURE / ENGINEERING / INTERIOR DESIGN

PROJECT TITLE: UConn Health Center Replacement CT Scanner  
 DRAWING TITLE: 263 Farmington Avenue Farmington, CT UCHC Project no. 08-050

**GENERAL INFORMATION**

NO.	DATE	REVISION	BY
1	01-13-04	APPENDIX NO. 1	
DATE	December 12, 2008		
SCALE			
PROJECT NO.	H080380		
DRAWING NO.	G001		

**PROJECT NARRATIVE**

REMOVE AN EXISTING CT SCANNER EQUIPMENT WITH A NEW SCANNER. SOURCE: 64 SLICE CT SCANNER WITHIN THE EXISTING UCONN HEALTH CENTER BUILDING AND CT SCAN SITE - 1A.01.01. REMOVE THE EXISTING CT SCANNER EQUIPMENT AND PREPARE SPACE FOR RECENT OF NEW EQUIPMENT. THIS PROJECT WILL INCLUDE THE INSTALLATION OF A NEWER CT SCANNER EQUIPMENT. THE EXISTING CT SCANNER EQUIPMENT IS TO BE REMOVED AND THE SPACE IS TO BE REUSED AS REQUIRED. INSTALLED AND OPERATIONAL THREE - FIVE YEARS BEFORE REOCCUPANCY. CONDUCT WORK RELATED TO MAKING THE RENOVATION OF CT SCAN SITE OPERATIONAL.

2. INSTALL AND COMPLETE ALL WORK RELATED TO MAKE THE RENOVATION OF CT SCANNER AND OF SITE OPERATIONAL.

3. NOTE - ALL RENOVATION, CONSTRUCTION RELATED SERVICES / UTILITIES AND FINISHES SHALL COMPLY WITH APPLICABLE CODES AND UCONN HEALTH CENTER STANDARDS. FULL LEGAL NOTICE WILL BE PROVIDED TO ALL AFFECTED PARTIES. ALL WORK SHALL BE MAINTAINED AND COORDINATED WITH THE EXISTING HOSPITAL STAFF.

**GENERAL NOTES**

- TOP OF SLAB ELEVATION = 0'-0"
- EXISTING CONTRACTOR IS RESPONSIBLE FOR THROUGHOUT REPAIRING ALL OF THE CONSTRUCTION DOCUMENTS TO CORRESPOND TO THIS WORK WITH OTHER TRADE CONTRACTORS.
- ALL CONTRACTORS SHALL FIELD VERIFY ALL DIMENSIONS AND NOTIFY THE ARCHITECT OF ANY DISCREPANCIES FOUND.
- THE LOCATION OF ALL TRAVELWAYS, STORAGE STRUCTURES, LAY DOWN AREAS, AND OTHER FEATURES SHALL BE APPROVED BY THE OWNER AND FIELD VERIFIED.
- SEAL NEW OPENINGS AROUND PIPE, CONDENS DUCTS, ETC. WITH AN APPROVED GROMMET. ALL NEW OPENINGS SHALL BE MADE IN ACCORDANCE WITH WALL SECTION PARTITION NOTES, SCHEDULE, AND CODE COMPLIANCE REQUIREMENTS.
- REFER TO PLUMBING, MECHANICAL, HVAC, FIRE PROTECTION AND ELECTRICAL DRAWINGS AND SPECIFICATIONS FOR LOCATIONS OF ALL CUES OR PUPS UNDER EQUIPMENT. COORDINATE LOCATIONS AND SIZES WITH APPROVED EQUIPMENT.
- BLOCKING REQUIREMENTS IN PERMANENT CONSTRUCTION FOR ALL NOT IN CONTRACT (N/C) EQUIPMENT SHALL BE PROVIDED BY THE CONTRACTOR.
- CONTRACTOR SHALL COORDINATE SCHEDULE OF ALL REQUIRED WORK WITH OTHER TRADES AND GENERAL CONTRACTOR. ALL WORK SHALL BE COMPLETED BY THE END OF THE PROJECT.
- CONTRACTOR SHALL COORDINATE CONTAINMENT AND PROCEEDURES OF ALL REQUIRED WORK WITH OTHER TRADES AND GENERAL CONTRACTOR.
- ANY PENETRATIONS THROUGH EXISTING WALLS OR NEW CONSTRUCTION SHALL BE FIELD VERIFIED TO BE IN ACCORDANCE WITH THE EXISTING WALL SECTION PARTITION NOTES, SCHEDULE, AND CODE COMPLIANCE REQUIREMENTS. OBTAIN ADDITIONAL FACILITY CODE REQUIREMENTS FROM THE OWNER.
- NEW WALL FLOOR, CEILING OR SHIRT WALL CONSTRUCTION SHALL MEET THE FIRE RATINGS LISTED IN THE CODE DATA ON 6001 AND 6002. REFER TO SHEET 6000 FOR RATED WALL LOCATIONS.
- GENERAL CONTRACTOR TO PATCH AND/OR REPAIR EXISTING FINISHES AND SYSTEMS DAMAGED BY DEMOLITION WORK, INCLUDING DEMOLITION BY OWNER PRIOR TO CONSTRUCTION TO MATCH EXISTING ADJACENT LITE WORK.
- AT ALL OPENINGS THROUGH WALLS FOR NEW DOORS AND WINDOWS PROVIDE NEW LIMITED OR EXCESSIVE. PROVIDE NEW LIMITED OR EXCESSIVE. PROVIDE NEW LIMITED OR EXCESSIVE.
- REFER TO ENGINEERING DRAWINGS FOR EQUIPMENT AND FINISHES TO BE REMOVED AND FOR OTHER REQUIRED OPENINGS FOR INSTALLATION OF NEW EQUIPMENT.
- NOTE - ALL EXISTING CORNER GUARDS ARE TO REMAIN. GENERAL CONTRACTOR IS TO CLEAN ALL EXISTING CORNER GUARDS.
- WALLWORK CORNER TOPS WHERE CORNERS ARE TO BE LOCATED TO HAVE A 2-1/2" DIAMETER GROMMET LOCATED IN THE BACK CENTER OF THE CORNER TOP AT EACH CORNER.
- CONTRACTOR TO INCLUDE IN REMOVAL, STORAGE AND REINSTALLATION OF EXISTING CEILING TILES WHEN NECESSARY AS NEW MATERIALS ARE INSTALLED IN PROJECT AREA ABOVE CEILING. CONTRACTOR WILL BE RESPONSIBLE FOR THE PROTECTION OF EXISTING CEILING TILES. CEILING TILES IN AS REQUIRED TO ACCOMMODATE FINISHES, BALLS PENETRATIONS, ETC.
- THANK IS TO REMOVE MORE AND GENERAL FINISHES AND EQUIPMENT WITHIN CT SITE TO ALLOW FOR PROJECT WORK. CONTRACTOR IS TO COORDINATE WITH OWNER TO EXERCISE SMOOTH REMOVAL OF DEBS AND FINISHES.
- EACH TRADE CONTRACTOR IS RESPONSIBLE FOR REVIEWING ALL OF THE CONSTRUCTION DOCUMENTS IN ORDER TO COORDINATE HIS WORK WITH THE OTHER TRADE CONTRACTORS.
- THE PLUMBING MECHANICAL, HVAC, SPRINKLER AND ELECTRICAL CONTRACTORS SHALL SEAL NEW OPENINGS AROUND PIPE, CONDITS, DUCTS, ETC. WITH FIRE STOPPING / SMOKE RESISTANT NON-COMBUSTIBLE MATERIALS. REFER TO CODE INT. AND RATINGS AT 6001 AND 6002.
- ACCESS PANELS WHICH ARE REQUIRED BY THE PLUMBING MECHANICAL, HVAC, SPRINKLER AND ELECTRICAL CONTRACTORS WHICH ARE NOT SHOWN ON THESE DRAWINGS SHALL BE PROVIDED BY THE RESPECTIVE CONTRACTOR FOR INSTALLATION AS REQUIRED BY GENERAL CONTRACTOR.
- NEW WALLS SHALL EXTEND TO THE UNDERSIDE OF DECK OR CONSTRUCTION ABOVE AND SEAL ALL PENETRATIONS TO PREVENT THE PASSAGE OF SMOKE.
- BRICK NEW GYM WALLBOARD PARTITIONS AS REQUIRED BY GENERAL CONTRACTOR AND PROVIDE METAL EDGE TRIM AND CORNER GUARDS AT EXPOSED CORNERS AND EDGES OF 6"RP BOARD.
- THE GENERAL CONTRACTOR SHALL SCHEMATE ALL WORK SO AS TO KEEP ALL STAIRWAYS, CORRIDORS AND OTHER EXIT COMPONENTS FREE OF OBSTRUCTION. STAIRWAYS, STAIRS, STAIRWAYS, ETC. COORDINATE WITH THE ARCHITECT FOR BLDG. OPERATIONS ONE WEEK IN ADVANCE WITH THE ARCHITECT'S PERMIT.
- THE GENERAL CONTRACTOR IS TO PATCH AND REPAIR AREAS DAMAGED BY DEMOLITION AS REQUIRED TO ACCEPT NEW FINISHES. THERE NO NEW CONDITIONS TO BE INSTALLED PERMIT TO MATCH EXISTING CONDITIONS OR BETTER.
- GENERAL CONTRACTOR TO VERIFY PERIODS OF THE WORK WILL OCCUR AHEAD OF THE PROJECT LEADING TO CEILING, ROOF, CORRIDORS, GROUND LEVEL, BASEMENT AND SUB BASEMENT BELOW CT SITE.
- GENERAL CONTRACTOR TO BE RESPONSIBLE FOR THE PROTECTION OF THE SPREAD OF DEBRIS AND CONTAMINANTS THROUGHOUT THE DURATION OF THE PROJECT AND TO PROTECT AREAS THAT CONTINUE TO SERVICE TENANTS AND USERS ADJACENT TO CONSTRUCTION.

**SYMBOLS**

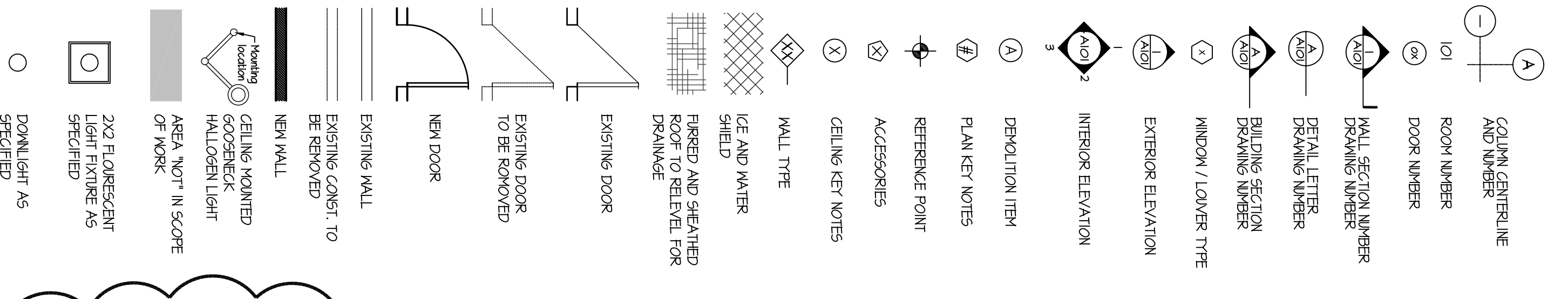

**ABBREVIATIONS**

49	CODE # CALL BRITON	N, N4	NORTH
10A	WALLBOARD CONSTRUCTION	N4	NORTH
10B	WALLBOARD CONSTRUCTION	N4	NORTH
10C	WALLBOARD CONSTRUCTION	N4	NORTH
10D	WALLBOARD CONSTRUCTION	N4	NORTH
10E	WALLBOARD CONSTRUCTION	N4	NORTH
10F	WALLBOARD CONSTRUCTION	N4	NORTH
10G	WALLBOARD CONSTRUCTION	N4	NORTH
10H	WALLBOARD CONSTRUCTION	N4	NORTH
10I	WALLBOARD CONSTRUCTION	N4	NORTH
10J	WALLBOARD CONSTRUCTION	N4	NORTH
10K	WALLBOARD CONSTRUCTION	N4	NORTH
10L	WALLBOARD CONSTRUCTION	N4	NORTH
10M	WALLBOARD CONSTRUCTION	N4	NORTH
10N	WALLBOARD CONSTRUCTION	N4	NORTH
10O	WALLBOARD CONSTRUCTION	N4	NORTH
10P	WALLBOARD CONSTRUCTION	N4	NORTH
10Q	WALLBOARD CONSTRUCTION	N4	NORTH
10R	WALLBOARD CONSTRUCTION	N4	NORTH
10S	WALLBOARD CONSTRUCTION	N4	NORTH
10T	WALLBOARD CONSTRUCTION	N4	NORTH
10U	WALLBOARD CONSTRUCTION	N4	NORTH
10V	WALLBOARD CONSTRUCTION	N4	NORTH
10W	WALLBOARD CONSTRUCTION	N4	NORTH
10X	WALLBOARD CONSTRUCTION	N4	NORTH
10Y	WALLBOARD CONSTRUCTION	N4	NORTH
10Z	WALLBOARD CONSTRUCTION	N4	NORTH
11A	WALLBOARD CONSTRUCTION	N4	NORTH
11B	WALLBOARD CONSTRUCTION	N4	NORTH
11C	WALLBOARD CONSTRUCTION	N4	NORTH
11D	WALLBOARD CONSTRUCTION	N4	NORTH
11E	WALLBOARD CONSTRUCTION	N4	NORTH
11F	WALLBOARD CONSTRUCTION	N4	NORTH
11G	WALLBOARD CONSTRUCTION	N4	NORTH
11H	WALLBOARD CONSTRUCTION	N4	NORTH
11I	WALLBOARD CONSTRUCTION	N4	NORTH
11J	WALLBOARD CONSTRUCTION	N4	NORTH
11K	WALLBOARD CONSTRUCTION	N4	NORTH
11L	WALLBOARD CONSTRUCTION	N4	NORTH
11M	WALLBOARD CONSTRUCTION	N4	NORTH
11N	WALLBOARD CONSTRUCTION	N4	NORTH
11O	WALLBOARD CONSTRUCTION	N4	NORTH
11P	WALLBOARD CONSTRUCTION	N4	NORTH
11Q	WALLBOARD CONSTRUCTION	N4	NORTH
11R	WALLBOARD CONSTRUCTION	N4	NORTH
11S	WALLBOARD CONSTRUCTION	N4	NORTH
11T	WALLBOARD CONSTRUCTION	N4	NORTH
11U	WALLBOARD CONSTRUCTION	N4	NORTH
11V	WALLBOARD CONSTRUCTION	N4	NORTH
11W	WALLBOARD CONSTRUCTION	N4	NORTH
11X	WALLBOARD CONSTRUCTION	N4	NORTH
11Y	WALLBOARD CONSTRUCTION	N4	NORTH
11Z	WALLBOARD CONSTRUCTION	N4	NORTH
12A	WALLBOARD CONSTRUCTION	N4	NORTH
12B	WALLBOARD CONSTRUCTION	N4	NORTH
12C	WALLBOARD CONSTRUCTION	N4	NORTH
12D	WALLBOARD CONSTRUCTION	N4	NORTH
12E	WALLBOARD CONSTRUCTION	N4	NORTH
12F	WALLBOARD CONSTRUCTION	N4	NORTH
12G	WALLBOARD CONSTRUCTION	N4	NORTH
12H	WALLBOARD CONSTRUCTION	N4	NORTH
12I	WALLBOARD CONSTRUCTION	N4	NORTH
12J	WALLBOARD CONSTRUCTION	N4	NORTH
12K	WALLBOARD CONSTRUCTION	N4	NORTH
12L	WALLBOARD CONSTRUCTION	N4	NORTH
12M	WALLBOARD CONSTRUCTION	N4	NORTH
12N	WALLBOARD CONSTRUCTION	N4	NORTH
12O	WALLBOARD CONSTRUCTION	N4	NORTH
12P	WALLBOARD CONSTRUCTION	N4	NORTH
12Q	WALLBOARD CONSTRUCTION	N4	NORTH
12R	WALLBOARD CONSTRUCTION	N4	NORTH
12S	WALLBOARD CONSTRUCTION	N4	NORTH
12T	WALLBOARD CONSTRUCTION	N4	NORTH
12U	WALLBOARD CONSTRUCTION	N4	NORTH
12V	WALLBOARD CONSTRUCTION	N4	NORTH
12W	WALLBOARD CONSTRUCTION	N4	NORTH
12X	WALLBOARD CONSTRUCTION	N4	NORTH
12Y	WALLBOARD CONSTRUCTION	N4	NORTH
12Z	WALLBOARD CONSTRUCTION	N4	NORTH
13A	WALLBOARD CONSTRUCTION	N4	NORTH
13B	WALLBOARD CONSTRUCTION	N4	NORTH
13C	WALLBOARD CONSTRUCTION	N4	NORTH
13D	WALLBOARD CONSTRUCTION	N4	NORTH
13E	WALLBOARD CONSTRUCTION	N4	NORTH
13F	WALLBOARD CONSTRUCTION	N4	NORTH
13G	WALLBOARD CONSTRUCTION	N4	NORTH
13H	WALLBOARD CONSTRUCTION	N4	NORTH
13I	WALLBOARD CONSTRUCTION	N4	NORTH
13J	WALLBOARD CONSTRUCTION	N4	NORTH
13K	WALLBOARD CONSTRUCTION	N4	NORTH
13L	WALLBOARD CONSTRUCTION	N4	NORTH
13M	WALLBOARD CONSTRUCTION	N4	NORTH
13N	WALLBOARD CONSTRUCTION	N4	NORTH
13O	WALLBOARD CONSTRUCTION	N4	NORTH
13P	WALLBOARD CONSTRUCTION	N4	NORTH
13Q	WALLBOARD CONSTRUCTION	N4	NORTH
13R	WALLBOARD CONSTRUCTION	N4	NORTH
13S	WALLBOARD CONSTRUCTION	N4	NORTH
13T	WALLBOARD CONSTRUCTION	N4	NORTH
13U	WALLBOARD CONSTRUCTION	N4	NORTH
13V	WALLBOARD CONSTRUCTION	N4	NORTH
13W	WALLBOARD CONSTRUCTION	N4	NORTH
13X	WALLBOARD CONSTRUCTION	N4	NORTH
13Y	WALLBOARD CONSTRUCTION	N4	NORTH
13Z	WALLBOARD CONSTRUCTION	N4	NORTH
14A	WALLBOARD CONSTRUCTION	N4	NORTH
14B	WALLBOARD CONSTRUCTION	N4	NORTH
14C	WALLBOARD CONSTRUCTION	N4	NORTH
14D	WALLBOARD CONSTRUCTION	N4	NORTH
14E	WALLBOARD CONSTRUCTION	N4	NORTH
14F	WALLBOARD CONSTRUCTION	N4	NORTH
14G	WALLBOARD CONSTRUCTION	N4	NORTH
14H	WALLBOARD CONSTRUCTION	N4	NORTH
14I	WALLBOARD CONSTRUCTION	N4	NORTH
14J	WALLBOARD CONSTRUCTION	N4	NORTH
14K	WALLBOARD CONSTRUCTION	N4	NORTH
14L	WALLBOARD CONSTRUCTION	N4	NORTH
14M	WALLBOARD CONSTRUCTION	N4	NORTH
14N	WALLBOARD CONSTRUCTION	N4	NORTH
14O	WALLBOARD CONSTRUCTION	N4	NORTH
14P	WALLBOARD CONSTRUCTION	N4	NORTH
14Q	WALLBOARD CONSTRUCTION	N4	NORTH
14R	WALLBOARD CONSTRUCTION	N4	NORTH
14S	WALLBOARD CONSTRUCTION	N4	NORTH
14T	WALLBOARD CONSTRUCTION	N4	NORTH
14U	WALLBOARD CONSTRUCTION	N4	NORTH
14V	WALLBOARD CONSTRUCTION	N4	NORTH
14W	WALLBOARD CONSTRUCTION	N4	NORTH
14X	WALLBOARD CONSTRUCTION	N4	NORTH
14Y	WALLBOARD CONSTRUCTION	N4	NORTH
14Z	WALLBOARD CONSTRUCTION	N4	NORTH
15A	WALLBOARD CONSTRUCTION	N4	NORTH
15B	WALLBOARD CONSTRUCTION	N4	NORTH
15C	WALLBOARD CONSTRUCTION	N4	NORTH
15D	WALLBOARD CONSTRUCTION	N4	NORTH
15E	WALLBOARD CONSTRUCTION	N4	NORTH
15F	WALLBOARD CONSTRUCTION	N4	NORTH
15G	WALLBOARD CONSTRUCTION	N4	NORTH
15H	WALLBOARD CONSTRUCTION	N4	NORTH
15I	WALLBOARD CONSTRUCTION	N4	NORTH
15J	WALLBOARD CONSTRUCTION	N4	NORTH
15K	WALLBOARD CONSTRUCTION	N4	NORTH
15L	WALLBOARD CONSTRUCTION	N4	NORTH
15M	WALLBOARD CONSTRUCTION	N4	NORTH
15N	WALLBOARD CONSTRUCTION	N4	NORTH
15O	WALLBOARD CONSTRUCTION	N4	NORTH
15P	WALLBOARD CONSTRUCTION	N4	NORTH
15Q	WALLBOARD CONSTRUCTION	N4	NORTH
15R	WALLBOARD CONSTRUCTION	N4	NORTH
15S	WALLBOARD CONSTRUCTION	N4	NORTH
15T	WALLBOARD CONSTRUCTION	N4	NORTH
15U	WALLBOARD CONSTRUCTION	N4	NORTH
15V	WALLBOARD CONSTRUCTION	N4	NORTH
15W	WALLBOARD CONSTRUCTION	N4	NORTH
15X	WALLBOARD CONSTRUCTION	N4	NORTH
15Y	WALLBOARD CONSTRUCTION	N4	NORTH
15Z	WALLBOARD CONSTRUCTION	N4	NORTH
16A	WALLBOARD CONSTRUCTION	N4	NORTH
16B	WALLBOARD CONSTRUCTION	N4	NORTH
16C	WALLBOARD CONSTRUCTION	N4	NORTH
16D	WALLBOARD CONSTRUCTION	N4	NORTH
16E	WALLBOARD CONSTRUCTION	N4	NORTH
16F	WALLBOARD CONSTRUCTION	N4	NORTH
16G	WALLBOARD CONSTRUCTION	N4	NORTH
16H	WALLBOARD CONSTRUCTION	N4	NORTH
16I	WALLBOARD CONSTRUCTION	N4	NORTH
16J	WALLBOARD CONSTRUCTION	N4	NORTH
16K	WALLBOARD CONSTRUCTION	N4	NORTH
16L	WALLBOARD CONSTRUCTION	N4	NORTH
16M	WALLBOARD CONSTRUCTION	N4	NORTH
16N	WALLBOARD CONSTRUCTION	N4	NORTH
16O	WALLBOARD CONSTRUCTION	N4	NORTH
16P	WALLBOARD CONSTRUCTION	N4	NORTH
16Q	WALLBOARD CONSTRUCTION	N4	NORTH
16R	WALLBOARD CONSTRUCTION	N4	NORTH
16S	WALLBOARD CONSTRUCTION	N4	NORTH
16T	WALLBOARD CONSTRUCTION	N4	NORTH
16U	WALLBOARD CONSTRUCTION	N4	NORTH
16V	WALLBOARD CONSTRUCTION	N4	NORTH
16W	WALLBOARD CONSTRUCTION	N4	NORTH
16X	WALLBOARD CONSTRUCTION	N4	NORTH
16Y	WALLBOARD CONSTRUCTION	N4	NORTH
16Z	WALLBOARD CONSTRUCTION	N4	NORTH
17A	WALLBOARD CONSTRUCTION	N4	NORTH
17B	WALLBOARD CONSTRUCTION	N4	NORTH
17C	WALLBOARD CONSTRUCTION	N4	NORTH
17D	WALLBOARD CONSTRUCTION	N4	NORTH
17E	WALLBOARD CONSTRUCTION	N4	NORTH
17F	WALLBOARD CONSTRUCTION	N4	NORTH
17G	WALLBOARD CONSTRUCTION	N4	NORTH
17H	WALLBOARD CONSTRUCTION	N4	NORTH
17I	WALLBOARD CONSTRUCTION	N4	NORTH
17J	WALLBOARD CONSTRUCTION	N4	NORTH
17K	WALLBOARD CONSTRUCTION	N4	NORTH
17L	WALLBOARD CONSTRUCTION	N4	NORTH
17M	WALLBOARD CONSTRUCTION	N4	NORTH
17N	WALLBOARD CONSTRUCTION	N4	NORTH
17O	WALLBOARD CONSTRUCTION	N4	NORTH
17P	WALLBOARD CONSTRUCTION	N4	NORTH
17Q	WALLBOARD CONSTRUCTION	N4	NORTH
17R	WALLBOARD CONSTRUCTION	N4	NORTH
17S	WALLBOARD CONSTRUCTION	N4	NORTH
17T	WALLBOARD CONSTRUCTION	N4	NORTH
17U	WALLBOARD CONSTRUCTION	N4	NORTH
17V	WALLBOARD CONSTRUCTION	N4	NORTH
17W	WALLBOARD CONSTRUCTION	N4	NORTH
17X	WALLBOARD CONSTRUCTION	N4	NORTH
17Y	WALLBOARD CONSTRUCTION	N4	NORTH
17Z	WALLBOARD CONSTRUCTION	N4	NORTH
18A	WALLBOARD CONSTRUCTION	N4	NORTH
18B	WALLBOARD CONSTRUCTION	N4	NORTH
18C	WALLBOARD CONSTRUCTION	N4	NORTH
18D	WALLBOARD CONSTRUCTION	N4	NORTH
18E	WALLBOARD CONSTRUCTION	N4	NORTH
18F	WALLBOARD CONSTRUCTION	N4	NORTH
18G	WALLBOARD CONSTRUCTION	N4	NORTH
18H	WALLBOARD CONSTRUCTION	N4	NORTH
18I	WALLBOARD CONSTRUCTION	N4	NORTH
18J	WALLBOARD CONSTRUCTION	N4	NORTH
18K	WALLBOARD CONSTRUCTION	N4	NORTH
18L	WALLBOARD CONSTRUCTION	N4	NORTH
18M	WALLBOARD CONSTRUCTION	N4	NORTH
18N	WALLBOARD CONSTRUCTION	N4	NORTH
18O	WALLBOARD CONSTRUCTION	N4	NORTH
18P	WALLBOARD CONSTRUCTION	N4	NORTH
18Q	WALLBOARD CONSTRUCTION	N4	NORTH
18R	WALLBOARD CONSTRUCTION	N4	NORTH
18S	WALLBOARD CONSTRUCTION	N4	NORTH
18T	WALLBOARD CONSTRUCTION	N4	NORTH
18U	WALLBOARD CONSTRUCTION	N4	NORTH
18V	WALLBOARD CONSTRUCTION	N4	NORTH
18W	WALLBOARD CONSTRUCTION	N4	NORTH
18X	WALLBOARD CONSTRUCTION	N4	NORTH
18Y	WALLBOARD CONSTRUCTION	N4	NORTH
18Z	WALLBOARD CONSTRUCTION	N4	NORTH
19A	WALLBOARD CONSTRUCTION	N4	NORTH
19B	WALLBOARD CONSTRUCTION	N4	NORTH

This drawing and details only, as an instrument of service, is the property of Fletcher Thompson and may be used only for this specific project and shall not be reproduced, stored in a retrieval system, or transmitted in any form or by any means, without the written consent of Fletcher Thompson.

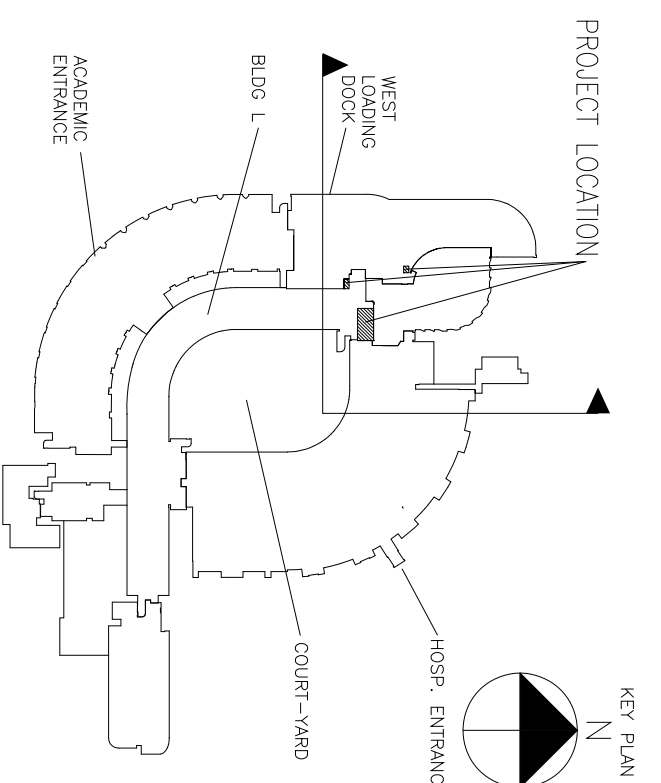

PROFESSIONAL SEAL

PROJECT MANAGER VN  
 ARCHITECT/DESIGNER HH  
 ENGINEER/DESIGNER HH  
 DRAWN BY HPH



**FLETCHER THOMPSON**  
 ARCHITECTURE / ENGINEERING / INTERIOR DESIGN

SHELTON, CONNECTICUT  
 203-223-6500  
 HARTFORD, CONNECTICUT  
 860-249-0888  
 SOMERSET, NEW JERSEY  
 732-907-6800  
 NEW YORK, NEW YORK  
 212-695-4767  
 NAPLES, FLORIDA  
 239-687-1220

**UConn Health Center  
 Replacement  
 CT Scanner**

263 Farmington Avenue  
 Farmington, CT  
 UCHC Project no. 08-050

**EGRESS FIRE  
 SAFETY AND RATING  
 PLAN**

PROJECT NO. H080380  
 DRAWING NO. **G100**

DATE December 12, 2008

SCALE  
 PROJECT NO. H080380  
 DRAWING NO. **G100**

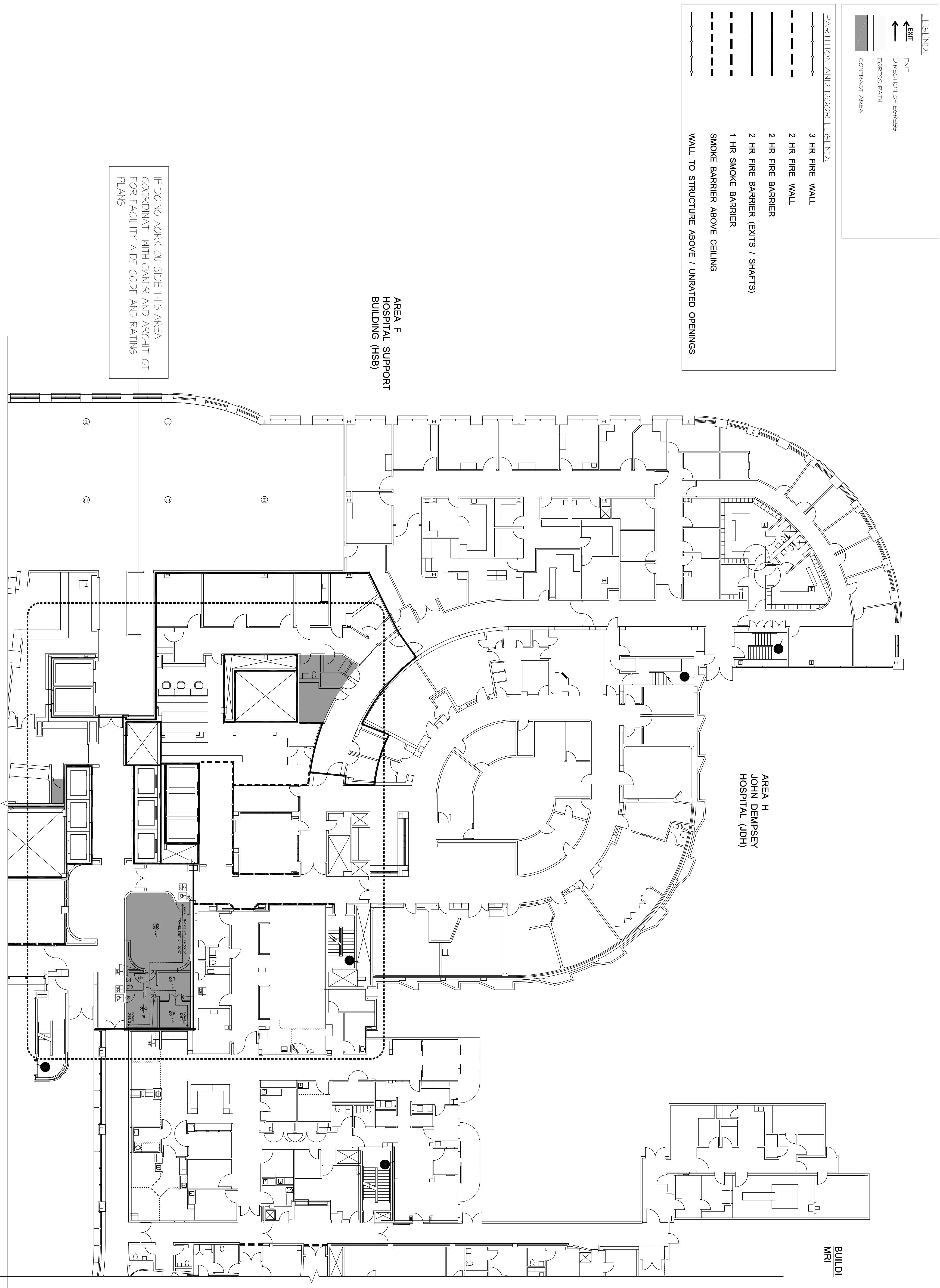

IF DOING WORK OUTSIDE THIS AREA  
 COORDINATE WITH OWNER AND ARCHITECT  
 FOR FACILITY WIDE CODE AND RATING  
 PLANS

AREA F  
 HOSPITAL SUPPORT  
 BUILDING (HSB)

AREA H  
 JOHN DEMPSEY  
 HOSPITAL (JDH)

BUILDING  
 MRI

**1 EGRESS FIRE SAFETY AND RATING PLAN**  
 SCALE: 1/8" = 1'-0"

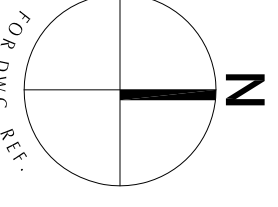

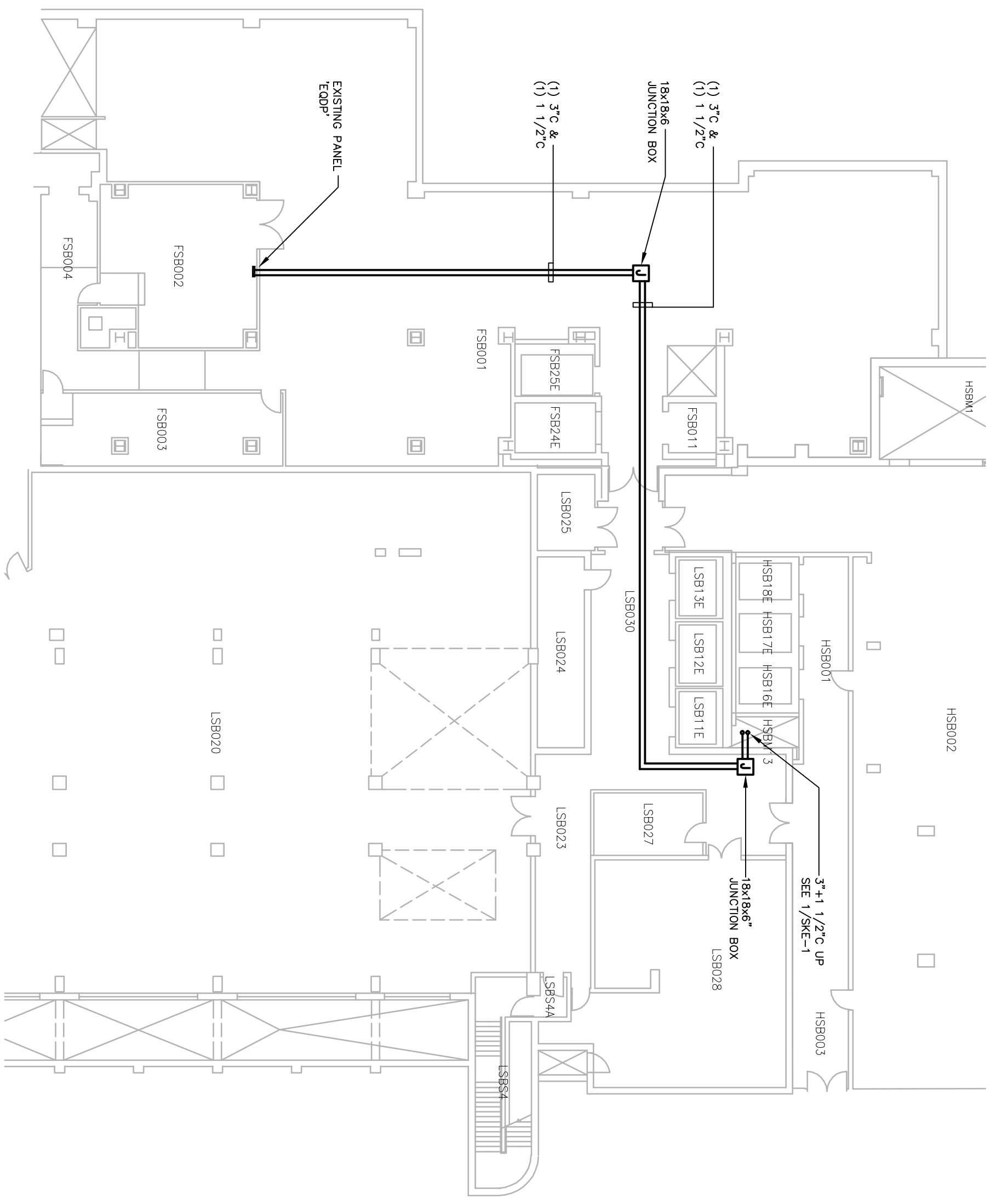

**2 SUB-BASEMENT LEVEL**  
SCALE: 1/16"=1'-0"

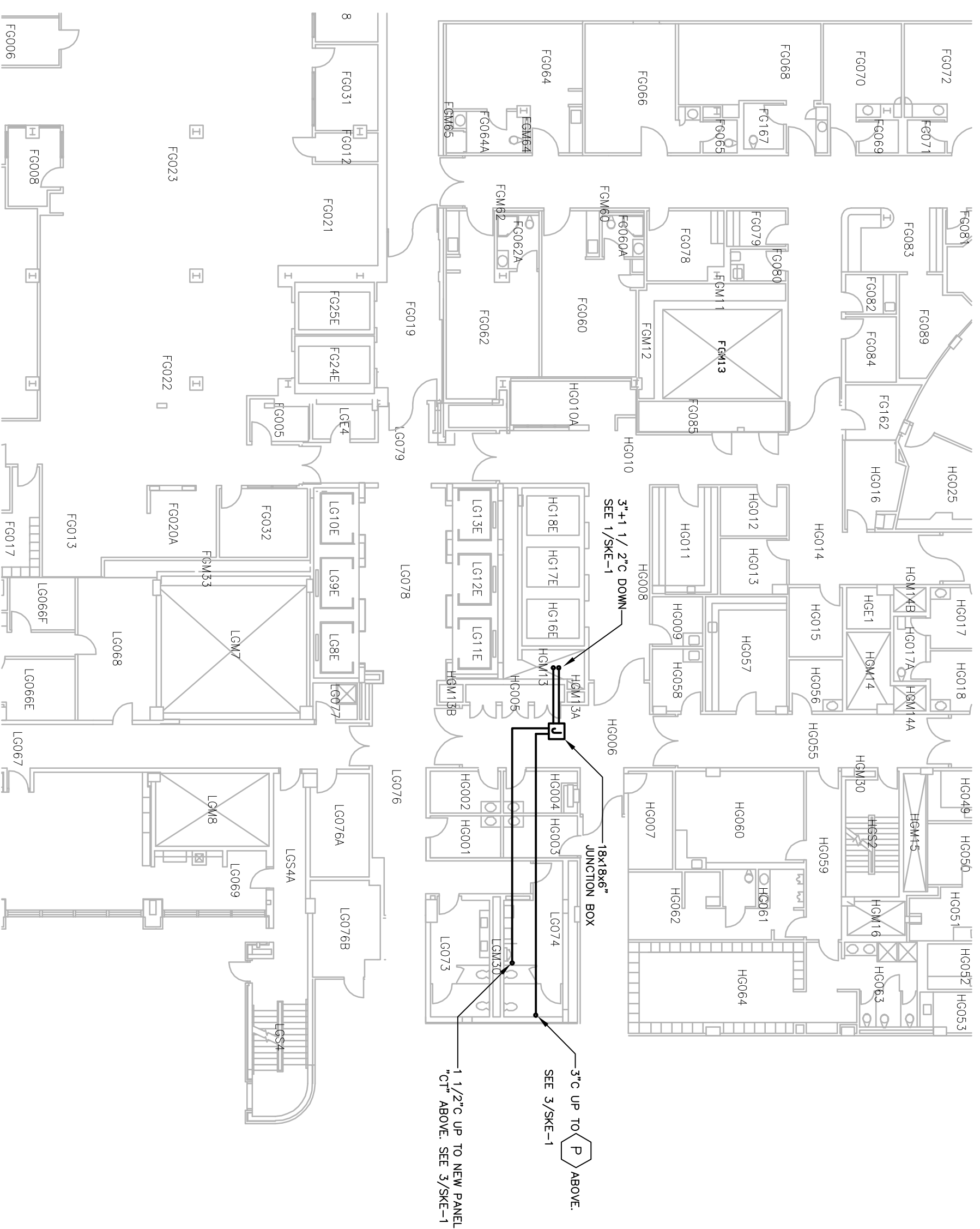

**1 GROUND LEVEL**  
SCALE: 1/16"=1'-0"

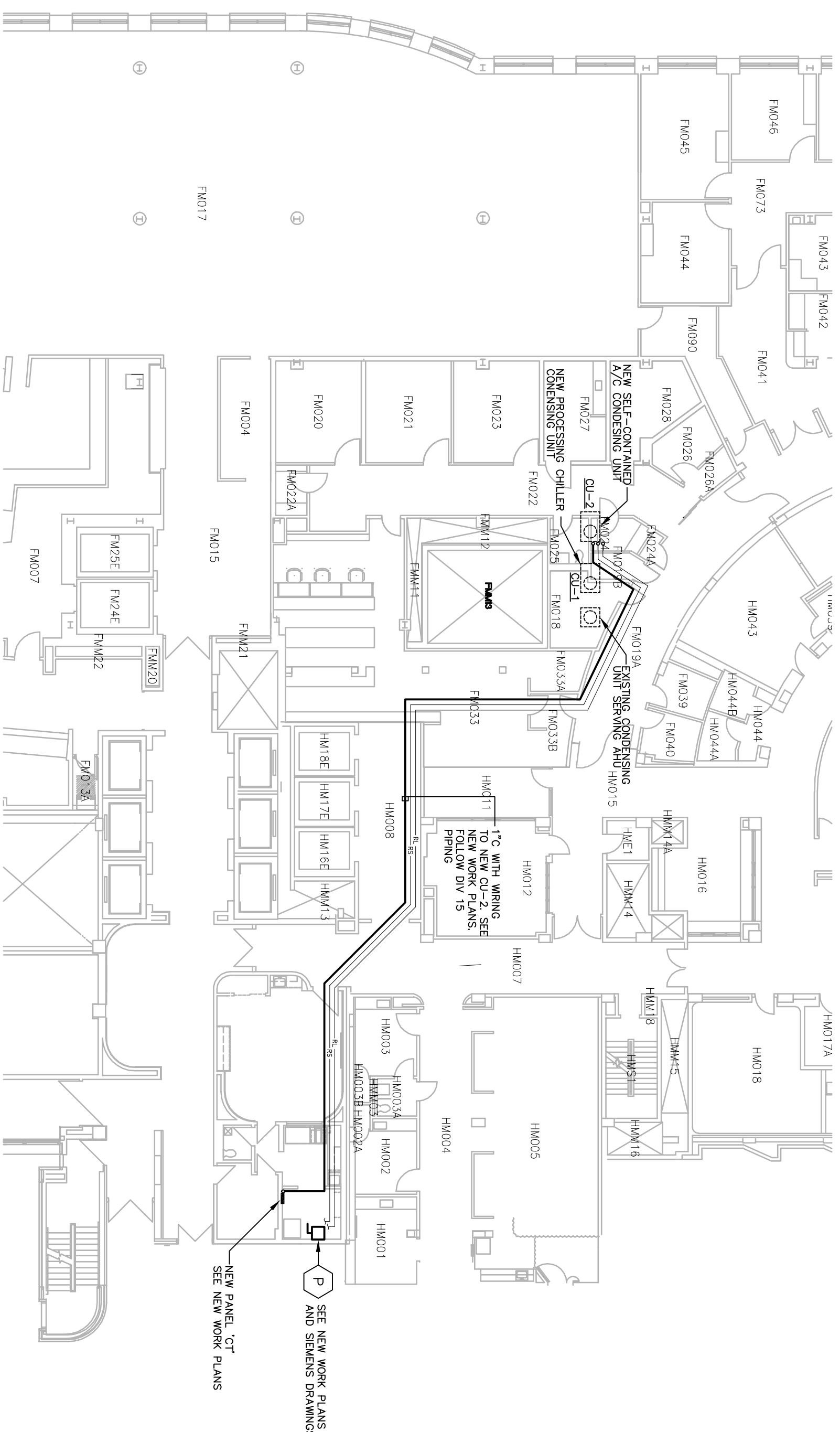

**3 MAIN LEVEL**  
SCALE: 1/16"=1'-0"

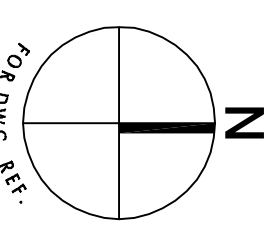

This drawing and details constitute an instrument of service. It is the property of Fletcher Thompson and may be used for this specific project and shall not be used for any other project without the written consent of Fletcher Thompson.

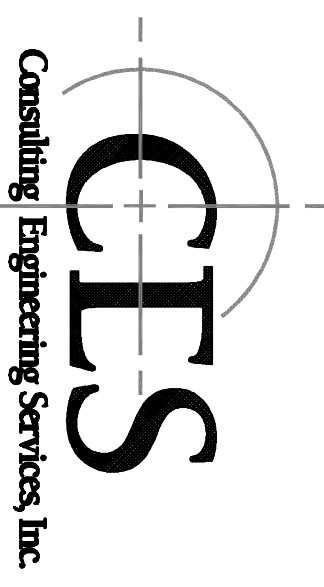

PROFESSIONAL SEAL

PROJECT MANAGER: V.N.  
ARCHITECT/DESIGNER: H.H.  
ENGINEER/DESIGNER: L.M.C.  
DRAWN BY: L.M.C./H.F.

**FLETCHER THOMPSON**  
ARCHITECTURE/ENGINEERING/INTERIOR DESIGN

SHELTON, CONNECTICUT  
203-225-6500  
HARTFORD, CONNECTICUT  
860-249-0888  
SOMERSET, NEW JERSEY  
732-907-6800  
NEW YORK, NEW YORK  
212-695-4767  
NAPLES, FLORIDA  
239-687-1220

**UConn Health Center**  
**Replacement**  
**CT Scanner**

263 Farmington Avenue  
Farmington, CT  
UChC Project no. 08-050

**SCANNER ROOM**  
**ELECTRICAL**  
**PART PLANS**

DATE: 01/13/09  
ADDENDUM #1

December 12, 2008

SCALE: 4" = 12'  
PROJECT NO: H080380

DRAWING NO: **SKE-01**







INVITATION TO BID

UHC-1 Rev. 5/07  
Previous Rev. 12/06

**Jennifer K. Kelley**  
*Purchasing Services Officer*

[jkk1011@adp.uchc.edu](mailto:jkk1011@adp.uchc.edu)  
*Email address*

**STATE OF CONNECTICUT**  
UNIVERSITY OF CONNECTICUT HEALTH CENTER  
FACILITY CONTRACTS & LEASES  
263 Farmington Avenue, MC4039  
Farmington, CT 06032  
860-679-8091



**Acknowledgment: Receipt of Bid Documents**  
**FAX to 860-284-5872**

Bid Number	Bid Due Date	Due Date Time
<b>4-0015</b>	<b>January 21, 2009</b>	<b>2:30 PM</b>
<b>Bid Title:</b>	<b>CT Scanner Replacement</b> This bid is restricted to State of CT Certified Small or Minority Owned Businesses.	

**This acknowledgement is crucial in maintaining vendor records for proposal follow-up procedures (i.e. addendum, questions regarding proposal).**

Please check one of the following boxes:  Submitting proposal  NOT submitting proposal

**Print or type the following information:**

Company name: \_\_\_\_\_

Address: \_\_\_\_\_

City or Town: \_\_\_\_\_

Phone: \_\_\_\_\_

Fax: \_\_\_\_\_

Received by: \_\_\_\_\_

email: \_\_\_\_\_

BIDDER'S CHECKLIST  
READ CAREFULLY

IT IS SUGGESTED THAT YOU REVIEW AND CHECK OFF EACH ACTION AS YOU COMPLETE IT.

- 1. **Complete and return** "Acknowledgement: Receipt of Bid Documents" (Form UCHC-1)
- 2. The Proposal (UCHC-3, UCHC-5) must be signed by a duly authorized representative of the company. Unsigned Proposals will automatically be rejected.
- 3. The Proposal Schedule (UCHC-4) must be included with your Proposal and contain the following:
  - a. VENDORS NAME MUST BE IN THE UPPER RIGHT CORNER OF ALL PROPOSAL SCHEDULE PAGES.
  - b. The Proposal prices you have offered have been reviewed and verified.
  - c. The price extensions and totals have been checked. (In case of discrepancy between unit prices and total prices, the unit price will govern the Proposal evaluation).
  - d. Any errors, alterations, corrections or erasures to unit prices, total prices, etc. must be initialed by the person who signs the proposal or his designee. Such changes made and not initialed mean automatic rejection of proposal.
  - e. The payment terms are Net 30 Days (You may offer cash discounts for prompt payment). Cash Discounts for Net Terms less than 30 days may be considered when evaluating Proposal pricing. Exception: State of CT Small Business Set-Aside bids payment terms shall be in accordance with CGS 4a-60j.
  - f. The delivery information block has been completed. Be specific: In most cases, "as ordered" or "as required" is not complete information.
- 4. Any technical or descriptive literature, drawing or Proposal samples that are required have been included with the Proposal.
- 5. Applicable Vendor Affidavits (see accompanying table) must be signed, notarized (where applicable), and returned with Proposal. Failure to do so may result in Proposal rejection.
- 6. If required the amount of Proposal surety has been checked and the surety has been included.
- 7. Form UCHC-5 (CHRO Compliance) must be completed entirely regardless of the number of employees (even if the company is family owned and/or operated) and must be submitted with each Proposal. Non-compliance may result in Proposal rejection.
- 8. Any addenda (UCHC-9, UCHC-10) to the bid have been signed and included.
- 9.. MAKE SURE TO INCLUDE THE ORIGINAL PROPOSAL SCHEDULE (UCHC-4) ALONG WITH ONE COPY (unless more copies are requested within the bid specifications).
- 10. The bid number on the pre-addressed mailing label or on your hand marked return envelope exactly matches the bid number inside the envelope.
- 11. The pre-addressed mailing label has been used on your Proposal envelope or the Proposal envelope has been addressed as follows:

<b>SEALED BID NO:</b>	<u>4-0015</u>
<b>NOT TO BE OPENED UNTIL:</b>	<u>January 21, 2009 at 2:30 PM</u>
<b>RETURN PROPOSAL TO:</b> <b>University of Connecticut Health Center</b> <b>263 Farmington Avenue MC 4039</b> <b>Farmington, CT 06030-4039</b>	

- 12. Hand-delivered Proposals are to be presented at **University of Connecticut Health Center, Department of Facility Contracts & Leases, 2<sup>nd</sup> Floor, 16 Munson Road, Farmington, CT 06032.**
- 13. The Proposal is to be mailed or hand-delivered in-time to be received no later than the designated opening date and time. Late Proposals are not accepted under any circumstances. Please allow enough time if mailing in your Proposal.

**THIS FORM IS NOT TO BE RETURNED WITH YOUR PROPOSAL**

INVITATION TO BID  
 UCHC-3 Rev. 8/07  
 Previous Rev. 5/07

# STATE OF CONNECTICUT

**Bid Number:**

**4-0015**

UNIVERSITY OF CONNECTICUT HEALTH CENTER

**Jennifer K. Kelley**

**DEPARTMENT OF FACILITY  
 CONTRACTS & LEASES**

*Purchasing Services Officer*

**263 Farmington Avenue, MC 4039**

**Farmington, CT 06032**

**Read & Complete**  
**Carefully**

**860-679-1988**

Telephone Number

Page 1 of 5

BID NO:	BID DUE DATE:	BID DUE TIME:	BID SURETY:	DATE ISSUED:
<b>4-0015</b>	<b>January 21, 2009</b>	<b>2:30 PM</b>	<b>See Proposal Schedule</b>	<b>December 23, 2008</b>

**DESCRIPTION:** **CT Scanner Replacement**  
**This bid is restricted to State of CT Certified Small or Minority Owned Businesses.**

**FOR:** **UConn Health Center**      **TERM OF CONTRACT:** **One time**

**Invitation to Bid:** Pursuant to the provisions of Section 10a-151b of the General Statutes of Connecticut as amended, sealed proposals will be received by the Department of Facility Contracts & Leases of the University of Connecticut Health Center, at the address above for furnishing the commodities and/or services.

**NOTE: Bidder means Individual/Sole Proprietor, Partnership or Corporation Name**

**IMPORTANT: ALL pages of this form, Sections 1 through 2 must be completed, signed and returned by the bidder as part of the bid package. Failure to submit all pages of this form may constitute grounds for rejection of your bid.**

### SECTION 1 of 2: *BIDDER INFORMATION*

COMPLETE BIDDER LEGAL BUSINESS NAME:	TAXPAYER ID # (TIN): <input type="checkbox"/> SSN <input type="checkbox"/> FEIN
WRITE/TYPE SSN/FEIN NUMBER ABOVE	

#### AFFIRMATION OF BIDDER

The above named bidder fully acknowledges and agrees with all the terms and conditions contained within the entire Invitation to Bid (Bid) document. Including but not limited to: Form UCHC-3 (HIPAA), the accompanying Bid proposal schedule, specifications, requirements and/or scope, and Bid Standard Terms and Conditions (Form UCHC-7). Further, if the above named bidder is awarded a contract for the goods and/or services contained within this Bid, the bidder's signature on Form UCHC-3 shall bind the bidder to all of the terms and conditions including but not limited to the aforementioned documents, including the bidder's formal response, which in total become the contract.

That should any part of this proposal be accepted in writing by Director of Purchasing within ninety (90) calendar days from the date of Bid opening, unless an earlier date for acceptance is specified by bidder in proposal schedule, said bidder will furnish and deliver the commodities and/or services to the state agency or agencies named, for which this proposal is made, in the quantities and at the prices bid, and in compliance with the provisions set forth in the terms and conditions of Forms UCHC-7, the proposal schedule and commodity specification Form UCHC-4. Should award of any part of this proposal be delayed beyond the period of ninety (90) days or an earlier date specified by bidder in proposal schedule, such award shall be conditioned upon bidder's acceptance.

Written signature of Person Authorized to sign on behalf of the above named Bidder: <b>SIGN HERE</b>	Date Executed
---	---------------

Type or Print Name of Authorized Person	Title of Authorized Person
---	----------------------------

Is your business <b>currently</b> a DAS <i>Certified</i> Small Business Enterprise?	<input type="checkbox"/> YES (Attach a copy of Certificate) <input type="checkbox"/> NO
---	---

If you are a <i>State Employee</i> , indicate your position, agency, and agency address:
--

INVITATION TO BID  
 UCHC-3 Rev. 8/07  
 Previous Rev. 5/07

# STATE OF CONNECTICUT

UNIVERSITY OF CONNECTICUT HEALTH CENTER  
 FACILITY CONTRACTS & LEASES

263 Farmington Avenue, MC 4039  
 Farmington, CT 06032

THIS FORM AND  
 REQUIRED PROPOSAL  
 SCHEDULE FORMS  
 MUST BE RETURNED

Jennifer K. Kelley  
 Purchasing Services Officer

860-679-1988  
 Telephone Number

**Read & Complete**  
**Carefully**  
**BID NO: 4-0015**

SECTION 1 of 2 –BIDDER INFORMATION (Continued)			
Bidder's Address		Remittance Address ( <input type="checkbox"/> Same as Bidder Address)	
No. and Street			
City, State , Zip Code			
Contact Person		Web Address	
Telephone Number		Cell Number	
Fax Number			
<b>Business entity:</b> <input type="checkbox"/> LLC <input type="checkbox"/> non-profit <input type="checkbox"/> partnership: <input type="checkbox"/> individual/sole proprietorship <input type="checkbox"/> CORPORATION    TYPE OF CORPORATION:    State Organized in:			
<b>Note:</b> If Individual/Sole Proprietor, Individual's Name (As Owner) Must Appear in the Legal Business Name Block above.			
<b>Business type:</b> A. sales of commodities    b. medical services    c. attorney fees    d. rental of property (real estate & equipment) E. other (describe in detail)			
Under this TIN, what is the primary type of business you provide the state? (enter letter from above)			
Under this TIN, what other types of business might you provide the state? (enter letter from above)			

<b>For Purchase Order Distribution:</b> 1) Check only one box below 2) Input e-mail address or Fax # (if checked)		
<input type="checkbox"/> E-mail	<input type="checkbox"/> Fax	<input type="checkbox"/> USPS Mail
Name:		
E-Mail Address:		
Telephone Number:		
<b>For Invitation to Bid (Bid) Distribution:</b> 1) Check only one box below 2) Input e-mail address or Fax # (if checked)		
<input type="checkbox"/> E-mail	<input type="checkbox"/> Fax	<input type="checkbox"/> USPS Mail

**Add further Business Address, E-mail & Contact Information below if required**

# STATE OF CONNECTICUT

## UNIVERSITY OF CONNECTICUT HEALTH CENTER FACILITY CONTRACTS & LEASES

THIS FORM AND  
REQUIRED PROPOSAL  
SCHEDULE FORMS  
MUST BE RETURNED

Jennifer K. Kelley

Purchasing Services Officer

263 Farmington Avenue, MC 4039

Farmington, CT 06032

**Read & Complete**

**Carefully**

860-679-1988

Telephone Number

Page 3 of 5

BID NO: 4-0015

### SECTION 2 of 2: PROPOSER DEBARMENT AND/OR SUSPENSION

The above signed bidder further affirms and declares that neither the bidder and/or any company official nor any subcontractor to the bidder and/or any company official has received any notices of debarment and/or suspension from contracting with the State of Connecticut. Should Facility Contracts & Leases determine that bidder has not completed Section 2 - Bidder Debarment and/or Suspension included as part of this document, and then such determination may be just cause for disqualification from the evaluation of this Bid.

YES  NO

The above signed bidder further affirms and declares that neither the bidder and/or any company official nor any subcontractor to the bidder and/or any company official has received any notices of debarment and/or suspension from contracting with other states within the United States.

YES  NO

#### **Certification Regarding Debarment, Suspension, Ineligibility and Voluntary Exclusion-Lower Tier Covered Transactions.**

This certification is required by the regulations implementing Executive Order 12549, Debarment and Suspension, 7 CFR part 3017, Section 3017.510, Participants' responsibilities. The regulations were published as Part IV of the January 30, 1989, Federal Register (pages 4722-4733).

#### Instructions for Certification

1. The prospective lower tier participant certifies, by submission of this proposal, that neither it nor its principals is presently debarred, suspended, proposed for debarment, declared ineligible, or voluntarily excluded from participation in this transaction by any Federal department or agency.
2. Where the prospective lower tier participant is unable to certify to any of the statements in this certification, such prospective participant shall attach an explanation to this proposal.
3. By submitting this form, the prospective lower tier participant is providing the certification set forth below in accordance with these instructions.
  - a. The certification in this clause is a material representation of fact upon which reliance was placed when this transaction was entered into. If it is later determined that the prospective lower tier participant knowingly rendered an erroneous certification, in addition to other remedies available to the Federal Government, the department or agency with which this transaction originated may pursue available remedies, including suspension and/or debarment.
  - b. The prospective lower tier participant shall provide immediate written notice to the person to which this proposal is submitted if at any time the prospective lower tier participant learns that its certification was erroneous when submitted or has become erroneous by reason of changed circumstances.
  - c. The terms "covered transaction," "debarred," "suspended," "ineligible," "lower tier covered transaction," "participant," "person," "primary covered transaction," "principal," "proposal," and "voluntarily excluded," as used in this clause, have the meanings set out in the Definitions and Coverage sections of rules implementing Executive Order 12549. You may contact the person to which this proposal is submitted for assistance in obtaining a copy of those regulations.
  - d. The prospective lower tier participant agrees by submitting this form that, should the proposed covered transaction be entered into, it shall not knowingly enter into any lower tier covered transaction with a person who is debarred, suspended, declared ineligible, or voluntarily excluded from participation in this covered transaction, unless authorized by the University of Connecticut Health Center.
  - e. The prospective lower tier participant further agrees by submitting this form that it will include this clause titled "Certification Regarding Debarment, Suspension, Ineligibility and Voluntary Exclusion - Lower Tier Covered Transaction," without modification, in all lower tier covered transactions and in all solicitations for lower tier covered transactions.
  - f. A participant in a covered transaction may rely upon a certification of a prospective participant in a lower tier covered transaction that is not debarred, suspended, ineligible, or voluntarily excluded from the covered transaction, unless it knows that the certification is erroneous. A participant may decide the method and frequency by which it determines the eligibility of its principals. Each participant may, but is not required to, check the Non-procurement List.
  - g. Nothing contained in the foregoing shall be construed to require establishment of a system of records in order to render in good faith the certification required by this clause. The knowledge and information of a participant is not required to exceed that which is normally possessed by a prudent person in the ordinary course of business dealings.

Except for transactions authorized under paragraph 3.(a) of these instructions, if a participant in a covered transaction knowingly enters into a lower tier covered transaction with a person who is suspended, debarred, ineligible, or voluntarily excluded from participation in this transaction, in addition to other remedies available to the Federal Government, the department or agency with which this transaction originated may pursue available remedies, including suspension and/or debarment

YES  NO

If the above signed bidder and/or any company official or any subcontractor to the bidder and/or any company official has received notices of debarment and/or suspension from contracting with the State of Connecticut, other states within the United States or Federal Government, said notices must be attached this document when submitted this proposal.

Number of notices attached:

# STATE OF CONNECTICUT

## UNIVERSITY OF CONNECTICUT HEALTH CENTER FACILITY CONTRACTS & LEASES

263 Farmington Avenue, MC 4039

Farmington, CT 06032

THIS FORM AND  
REQUIRED PROPOSAL  
SCHEDULE FORMS  
MUST BE RETURNED

Jennifer K. Kelley  
Purchasing Services Officer

860-679-1988

Telephone Number

Page 4 of 5

**Read & Complete**  
**Carefully**

**Bid No. 4-0015**

### UNIVERSITY OF CONNECTICUT HEALTH CENTER BUSINESS ASSOCIATE AGREEMENT

#### Health Insurance Portability and Accountability Act of 1996 ("HIPAA")

##### Contractors' Compliance Certification Regarding Confidentiality and Disclosure of Patient Healthcare Information

Contractor, its agents and employees (collectively, "Contractor") acknowledge that it may have access to confidential protected health information ("PHI"), including, but not limited to, patient identifying information. References to PHI include electronic protected health information ("ePHI").

Contractor agrees that it:

- (a) If the Contractor is a Business Associate under the requirements of the Health Insurance Portability and Accountability Act of 1996 ("HIPAA"), the Contractor must comply with all terms and conditions of this Section of the Contract. If the Contractor is not a Business Associate under HIPAA, this Section of the Contract does not apply to the Contractor for this Contract.
- (b) The Contractor is required to safeguard the use, publication and disclosure of information on all applicants for, and all clients who receive, services under the Contract in accordance "with all applicable federal and state law regarding confidentiality, which includes but is not limited to ("HIPAA"), more specifically with the Privacy and Security Rules at 45 C.F.R. Part 160 and Part 164, subparts A, C, and E; *and*
- (c) The State of Connecticut Department named on page 1 of this Contract (hereinafter "Department") is a "covered entity" as that term is defined in 45 C.F.R. § 160.103; *and*
- (d) The Contractor, on behalf of the Department, performs functions that involve the use or disclosure of "individually identifiable health information," as that term is defined in 45 C.F.R. § 160.103; *and*
- (e) The Contractor is a "business associate" of the Department, as that term is defined in 45 C.F.R. § 160.103; *and*
- (f) The Contractor and the Department agree to the following in order to secure compliance with the HIPAA, more specifically with the Privacy and Security Rules at 45 C.F.R. Part 160 and Part 164, subparts A, C, and E.
  - (g) Definitions
    - (1) "Business Associate" shall mean the Contractor.
    - (2) "Covered Entity" shall mean the Department of the State of Connecticut named on page 1 of this Contract.
    - (3) "Designated Record Set" shall have the same meaning as the term "designated record set" in 45 C.F.R. § 164.501.
    - (4) "Individual" shall have the same meaning as the term "individual" in 45 C.F.R. § 160.103 and shall include a person who qualifies as a personal representative as defined in 45 C.F.R. § 164.502(g).
    - (5) "Privacy Rule" shall mean the Standards for Privacy of Individually Identifiable Health Information at 45 C.F.R. part 160 and parts 164, subparts A and E.
    - (6) "Protected Health Information" or "PHI" shall have the same meaning as the term "protected health information" in 45 C.F.R. § 160.103, limited to information created or received by the Business Associate from or on behalf of the Covered Entity.
    - (7) "Required by Law" shall have the same meaning as the term "required by law" in 45 C.F.R. § 164.103.
    - (8) "Secretary" shall mean the Secretary of the Department of Health and Human Services or his designee.
    - (9) "More stringent" shall have the same meaning as the term "more stringent" in 45 C.F.R. § 160.202.
    - (10) "This Section of the Contract" refers to the HIPAA Provisions stated herein, in their entirety.
    - (11) "Security Incident" shall have the same meaning as the term "security incident" in 45 C.F.R. § 164.304.
    - (12) "Security Rule" shall mean the Security Standards for the Protection of Electronic Protected Health Information at 45 C.F.R. part 160 and parts 164, subpart A and C.
  - (h) Obligations and Activities of Business Associates.
    - (1) Business Associate agrees not to use or disclose PHI other than as permitted or required by this Section of the Contract or as Required by Law.
    - (2) Business Associate agrees to use appropriate safeguards to prevent use or disclosure of PHI other than as provided for in this Section of the Contract.
    - (3) Business Associate agrees to use administrative, physical and technical safeguards that reasonably and appropriately protect the confidentiality, integrity, and availability of electronic protected health information that it creates, receives, maintains, or transmits on behalf of the Covered Entity.
    - (4) Business Associate agrees to mitigate, to the extent practicable, any harmful effect that is known to the Business Associate of a use or disclosure of PHI by Business Associate in violation of this Section of the Contract.
    - (5) Business Associate agrees to report to Covered Entity any use or disclosure of PHI not provided for by this Section of the Contract or any security incident of which it becomes aware.
    - (6) Business Associate agrees to insure that any agent, including a subcontractor, to whom it provides PHI received from, or created or received by Business Associate, on behalf of the Covered Entity, agrees to the same restrictions and conditions that apply through this Section of the Contract to Business Associate with respect to such information.
    - (7) Business Associate agrees to provide access, at the request of the Covered Entity, and in the time and manner agreed to by the parties, to PHI in a Designated Record Set, to Covered Entity or, as directed by Covered Entity, to an Individual in order to meet the requirements under 45 C.F.R. § 164.524.
    - (8) Business Associate agrees to make any amendments to PHI in a Designated Record Set that the Covered Entity directs or agrees to pursuant to 45 C.F.R. § 164.526 at the request of the Covered Entity, and in the time and manner agreed to by the parties.
    - (9) Business Associate agrees to make internal practices, books, and records, including policies and procedures and PHI, relating to the use and disclosure of PHI received from, or created or received by, Business Associate on behalf of Covered Entity, available to Covered Entity or to the Secretary in a time and manner agreed to by the parties or designated by the Secretary, for purposes of the Secretary determining Covered Entity's compliance with the Privacy Rule.
    - (10) Business Associate agrees to document such disclosures of PHI and information related to such disclosures as would be required for Covered Entity to respond to a request by an Individual for an accounting of disclosures of PHI in accordance with 45 C.F.R. § 164.528.
    - (11) Business Associate agrees to provide to Covered Entity, in a time and manner agreed to by the parties, information collected in accordance with paragraph I of this Section of the Contract, to permit Covered Entity to respond to a request by an Individual for an accounting of disclosures of PHI in accordance with 45 C.F.R. § 164.528.
    - (12) Business Associate agrees to comply with any state law that is more stringent than the Privacy Rule.
  - (i) Permitted Uses and Disclosure by Business Associate.
    - (1) General Use and Disclosure Provisions Except as otherwise limited in this Section of the Contract, Business Associate may use or disclose PHI to perform functions, activities, or services for, or on behalf of, Covered Entity as specified in this Contract, provided that such use or disclosure would not violate the Privacy Rule if done by Covered Entity or the minimum necessary policies and procedures of the Covered Entity.
    - (2) Specific Use and Disclosure Provisions

# STATE OF CONNECTICUT

## UNIVERSITY OF CONNECTICUT HEALTH CENTER FACILITY CONTRACTS & LEASES

263 Farmington Avenue, MC 4039

Farmington, CT 06032

THIS FORM AND  
REQUIRED PROPOSAL  
SCHEDULE FORMS  
MUST BE RETURNED

Jennifer K. Kelley  
Purchasing Services Officer

860-679-1988

Telephone Number

Page 5 of 5

**Read & Complete**  
**Carefully**

**Bid No. 4-0015**

### UNIVERSITY OF CONNECTICUT HEALTH CENTER BUSINESS ASSOCIATE AGREEMENT

#### Health Insurance Portability and Accountability Act of 1996 (“HIPAA”)

##### Contractors’ Compliance Certification Regarding Confidentiality and Disclosure of Patient Healthcare Information

- (A) Except as otherwise limited in this Section of the Contract, Business Associate may use PHI for the proper management and administration of Business Associate or to carry out the legal responsibilities of Business Associate.
  - (B) Except as otherwise limited in this Section of the Contract, Business Associate may disclose PHI for the proper management and administration of Business Associate, provided that disclosures are Required by Law, or Business Associate obtains reasonable assurances from the person to whom the information is disclosed that it will remain confidential and used or further disclosed only as Required by Law or for the purpose for which it was disclosed to the person, and the person notifies Business Associate of any instances of which it is aware in which the confidentiality of the information has been breached.
  - (C) Except as otherwise limited in this Section of the Contract, Business Associate may use PHI to provide Data Aggregation services to Covered Entity as permitted by 45 C.F.R. § 164.504(e)(2)(i)(B).
- (j) Obligations of Covered Entity.
- (1) Covered Entity shall notify Business Associate of any limitations in its notice of privacy practices of Covered Entity, in accordance with 45 C.F.R. § 164.520, or to the extent that such limitation may affect Business Associate’s use or disclosure of PHI.
  - (2) Covered Entity shall notify Business Associate of any changes in, or revocation of, permission by Individual to use or disclose PHI, to the extent that such changes may affect Business Associate’s use or disclosure of PHI.
  - (3) Covered Entity shall notify Business Associate of any restriction to the use or disclosure of PHI that Covered Entity has agreed to in accordance with 45 C.F.R. § 164.522, to the extent that such restriction may affect Business Associate’s use or disclosure of PHI.
- (k) Permissible Requests by Covered Entity. Covered Entity shall not request Business Associate to use or disclose PHI in any manner that would not be permissible under the Privacy Rule if done by the Covered Entity, except that Business Associate may use and disclose PHI for data aggregation, and management and administrative activities of Business Associate, as permitted under this Section of the Contract.
- (l) Term and Termination.
- (1) Term. The Term of this Section of the Contract shall be effective as of the date the Contract is effective and shall terminate when all of the PHI provided by Covered Entity to Business Associate, or created or received by Business Associate on behalf of Covered Entity, is destroyed or returned to Covered Entity, or, if it is infeasible to return or destroy PHI, protections are extended to such information, in accordance with the termination provisions in this Section.
  - (2) Termination for Cause Upon Covered Entity’s knowledge of a material breach by Business Associate, Covered Entity shall either:
    - (A) Provide an opportunity for Business Associate to cure the breach or end the violation and terminate the Contract if Business Associate does not cure the breach or end the violation within the time specified by the Covered Entity; or
    - (B) Immediately terminate the Contract if Business Associate has breached a material term of this Section of the Contract and cure is not possible; or
    - (C) If neither termination nor cure is feasible, Covered Entity shall report the violation to the Secretary
  - (3) Effect of Termination
    - (A) Except as provided in (1)(2) above, upon termination of this Contract, for any reason, Business Associate shall return or destroy all PHI received from Covered Entity, or created or received by Business Associate on behalf of Covered Entity. This provision shall apply to PHI that is in the possession of subcontractors or agents of Business Associate. Business Associate shall retain no copies of the PHI.
    - (B) In the event that Business Associate determines that returning or destroying the PHI is infeasible, Business Associate shall provide to Covered Entity notification of the conditions that make return or destruction infeasible. Upon documentation by Business Associate that return of destruction of PHI is infeasible, Business Associate shall extend the protections of this Section of the Contract to such PHI and limit further uses and disclosures of PHI to those purposes that make return or destruction infeasible, for as long as Business Associate maintains such PHI. Infeasibility of the return or destruction of PHI includes, but is not limited to, requirements under state or federal law that the Business Associate maintains or preserves the PHI or copies thereof.
- (m) Miscellaneous Provisions.
- (1) Regulatory References. A reference in this Section of the Contract to a section in the Privacy Rule means the section as in effect or as amended.
  - (2) Amendment. The Parties agree to take such action as is necessary to amend this Section of the Contract from time to time as is necessary for Covered Entity to comply with requirements of the Privacy Rule and the Health Insurance Portability and Accountability Act of 1996, Pub. L. No. 104-191.
  - (3) Survival. The respective rights and obligations of Business Associate shall survive the termination of this Contract.
  - (4) Effect on Contract. Except as specifically required to implement the purposes of this Section of the Contract, all other terms of the Contract shall remain in force and effect.
  - (5) Construction. This Section of the Contract shall be construed as broadly as necessary to implement and comply with the Privacy Standard. Any ambiguity in this Section of the Contract shall be resolved in favor of a meaning that complies, and is consistent with, the Privacy Standard.
  - (6) Disclaimer. Covered Entity makes no warranty or representation that compliance with this Section of the Contract will be adequate or satisfactory for Business Associate’s own purposes. Covered Entity shall not be liable to Business Associate for any claim, loss or damage related to or arising from the unauthorized use or disclosure of PHI by Business Associate or any of its officers, directors, employees, Contractors or agents, or any third party to whom Business Associate has disclosed PHI pursuant to this Contract. Business Associate is solely responsible for all decisions made, and actions taken, by Business Associate regarding the safeguarding, use and disclosure of PHI within its possession, custody or control.
  - (7) Indemnification. The Business Associate shall indemnify and hold the Covered Entity harmless from and against all claims, liabilities, judgments, fines, assessments, penalties, awards, or other expenses, of any kind or nature whatsoever, including, without limitation, attorney’s fees, expert witness fees, and costs of investigation, litigation or dispute resolution, relating to or arising out of any violation by the Business Associate and its agents, including subcontractors, of any obligation of Business Associate and its agents, including subcontractors, under this Section of the Contract.

Contractor recognizes that PHI shall be and remain the property of UCHC and agrees that it acquires no title or rights to PHI, including any de-identified information, as a result of this Agreement. Contractor further recognizes and agrees that any breach of confidentiality or misuse of information found in and/or obtained from records may result in the termination of this Agreement and/or legal action, including reporting to the Secretary of Health and Human Services.

YES (Applicable)  NO (Non-Applicable)

**INVITATION TO BID**  
 UCHC-4 Rev. 5/07  
 Previous Rev. 12/04

**Jennifer K. Kelley**  
*Purchasing Services Officer*

**860-679-1988**  
*Telephone Number*

**STATE OF CONNECTICUT**

**UNIVERSITY OF CONNECTICUT HEALTH CENTER**

**FACILITY CONTRACTS & LEASES**  
 263 Farmington Avenue, MC 4039  
 Farmington, CT 06032

**Proposal Schedule**

Page 1 of 5

Payment terms are net 30 days after receipt of invoice.  
 Any deviation may result in proposal rejection.

Bid prices shall include all transportation charges FOB  
 University of Connecticut Health Center.

<b>Bid Number:</b>	4-0015
<b>Delivery:</b>	
<b>Terms:</b>	Cash Discount:
%	# Days
<b>Bidder Name:</b>	
<b>SSN or FEIN #:</b>	

Item no.	Description of commodity and/or services	Qty.	Unit	Unit Price	Total Price
----------	--	------	------	------------	-------------

<p><b>Project Title: CT Scanner Replacement</b>  <b>Project Number: 08-050</b></p>	<p align="center"><b>THIS BID IS RESTRICTED TO          STATE OF CT CERTIFIED          SMALL OR MINORITY          OWNED BUSINESSES.</b></p>
<p>Provide all labor, material and equipment required to renovate rooms LM079, LM079A, LM078 &amp; LM078A as defined in drawings G001, A100, A101, MD-1, M-1, M-2, PFPD-1, PFP-1, ED-1, EP-1, EL-1 dated 12-12-08 by Fletcher Thompson Architects and drawing sheets A-101, A-201, S-202, S-102, S-501, E-101, E-501, M-101, M-501 dated 11-21-08 issued by Siemens Medical Equipment and specifications dated 12-12-08 issued by Fletcher Thompson Architects, to replace the existing CT scanner. The supply and installation of the CT equipment is to be done by the equipment vendor. The scope of this project prepares these rooms to receive the equipment.</p>	
<p>This is a Prevailing Wage project. Prevailing Wage rates are attached following this proposal schedule.</p>	
<p><b><u>Mandatory prebid will be held at 1:00 PM on January 6, 2009 in the Onyiuke Dining Room (FM002) by the cafeteria at 263 Farmington Avenue, Farmington, CT 06032</u></b></p>	
<p>(Park in Shuttle Lot 3, take the shuttle to the Main Hospital Entrance, turn right at the back of the Lobby, and follow the corridor past the elevators to the cafeteria)</p>	
<p><b>Bidders should purchase drawings from Joseph Merritt &amp; Company, 650 Franklin Ave, Hartford, CT. Phone: 860-296-2500</b></p>	
<p><b><u>Bidders note:</u></b></p>	



**INVITATION TO BID**  
 UCHC-4 Rev. 5/07  
 Previous Rev. 12/04

**Jennifer K. Kelley**  
*Purchasing Services Officer*

**860-679-1988**  
*Telephone Number*

**STATE OF CONNECTICUT**

**UNIVERSITY OF CONNECTICUT HEALTH CENTER**

**FACILITY CONTRACTS & LEASES**  
 263 Farmington Avenue, MC 4039  
 Farmington, CT 06032

**Proposal Schedule**

Page 2 of 5

Payment terms are net 30 days after receipt of invoice.  
 Any deviation may result in proposal rejection.

Bid prices shall include all transportation charges FOB  
 University of Connecticut Health Center.

<b>Bid Number:</b>	
4-0015	
<b>Delivery:</b>	
<b>Terms:</b>	<b>Cash Discount:</b>
%	# Days
<b>Bidder Name:</b>	
<b>SSN or FEIN #:</b>	

Item no.	Description of commodity and/or services	Qty.	Unit	Unit Price	Total Price
	<p>1. In accordance with C.G.S §4a-100, all Bidders shall be prequalified by the DAS Contractor Prequalification Program before they can bid on a contract or perform work pursuant to a contract for the construction, reconstruction, alteration, remodeling, repair or demolition of any public building or any other public work by the state or a municipality, which is funded in whole or in part with state funds..</p> <p>2. As well as the standard submission requirements listed on the checklist at the start of the bid package, the following forms must also be completed and submitted with your bid. They are located in the specification book:</p> <ul style="list-style-type: none"> <li>• The Bid Form document which includes the pricing information, unit pricing, subdivision of contract price, schedule of values and contractors' certification.</li> <li>• The AIA Documents "Contractor's Qualification Statement" and Financials</li> </ul> <p>3. Any worker who will be on the campus in the performance of this work must adhere to the UCHC Background and Federal Sanctions Policy #2001-3. A copy of the background information form will be provided to the bidder awarded the contract and it must be completed and approved by Public Safety before any employee can start work on campus. <b><u>Effective July 1, 2008, the UCHC Public Safety Department shall institute a fee of \$75.00 for each background check completed.</u></b> The fee is payable in advance and shall accompany the submission of the Background Information Sheet</p> <p>All bidders must agree to carry sufficient worker's compensation and liability insurance in a company</p>				

**INVITATION TO BID**  
 UCHC-4 Rev. 5/07  
 Previous Rev. 12/04

**Jennifer K. Kelley**  
*Purchasing Services Officer*

**860-679-1988**  
*Telephone Number*

**STATE OF CONNECTICUT**

**UNIVERSITY OF CONNECTICUT HEALTH CENTER**

**FACILITY CONTRACTS & LEASES**  
 263 Farmington Avenue, MC 4039  
 Farmington, CT 06032

**Proposal Schedule**

Page 3 of 5

Payment terms are net 30 days after receipt of invoice.  
 Any deviation may result in proposal rejection.

Bid prices shall include all transportation charges FOB  
 University of Connecticut Health Center.

<b>Bid Number:</b>	
4-0015	
<b>Delivery:</b>	
<b>Terms:</b>	<b>Cash Discount:</b>
%	# Days
<b>Bidder Name:</b>	
<b>SSN or FEIN #:</b>	

Item no.	Description of commodity and/or services	Qty.	Unit	Unit Price	Total Price
	<p>licensed to do business in Connecticut and to furnish certificates of insurance should award be made to said bidder for the contract of this construction.</p> <p>All bidders must agree and warrant that in the performance of this contract, he/she will not discriminate or permit discrimination against any person or group of persons on the ground of race, color, religion, national origin, sex or physical disability, including, but not limited to, blindness, unless it is shown by such Contractor that such disability prevents performance of the work involved in any manner, prohibited by the laws of the United States or the State of Connecticut, and further agrees to provide the Commission on Human Rights and Opportunities (CHRO) with such information requested by the Commission concerning the employment practices and procedures of the Contractor as they relate to the provisions of this section.</p> <p>Enforcement of Affirmative Action plan requirements of Public Works contractors: The Commission on Human Rights and Opportunities (CHRO) will rigorously enforce the Regulations concerning Contract Compliance, 46a-68j-21 through 46a-68j-43, in particular, sections 26, 27 and 28, regarding affirmative action obligations of Public Works contractors. These sections require contractors who are successful bidders on Public Works contracts of \$50,000 or more to submit to, and have approved by CHRO, an affirmative action plan prior to the award of any such contract as required by CT General Statutes as amended by Section 8 of Public Act 99-75.</p>				

**INVITATION TO BID**  
 UCHC-4 Rev. 5/07  
 Previous Rev. 12/04

**Jennifer K. Kelley**  
*Purchasing Services Officer*

**860-679-1988**  
*Telephone Number*

**STATE OF CONNECTICUT**

**UNIVERSITY OF CONNECTICUT HEALTH CENTER**

**FACILITY CONTRACTS & LEASES**  
 263 Farmington Avenue, MC 4039  
 Farmington, CT 06032

**Proposal Schedule**

Page 4 of 5

Payment terms are net 30 days after receipt of invoice.  
 Any deviation may result in proposal rejection.

Bid prices shall include all transportation charges FOB  
 University of Connecticut Health Center.

**Bid Number:**  
 4-0015

**Delivery:**

<b>Terms:</b>	<b>Cash Discount:</b>
%	# Days

**Bidder Name:**

**SSN or FEIN #:**

Item no.	Description of commodity and/or services	Qty.	Unit	Unit Price	Total Price
	<p>Department of Administrative Services:            Pursuant to CT General Statute 4a-60g:            1) Twenty-five percent of the total contract value shall be contracted through State of Connecticut Certified Small Businesses. Note: If award winner is a State of Connecticut Certified Small Business, the contractor is exempt from this requirement (Item No. 2 applies).            2) Six and a quarter percent of the total contract value shall be contracted through State of Connecticut Certified Minority and Woman-Owned Business.</p> <p>If required, the wages paid on an hourly basis to any mechanic, laborer, or workman employed on the work herein contracted to be done and the amount of payment or contribution paid or payable on behalf of each such employee to any employee welfare fund shall be a rate equal to the rate customary or prevailing for the same work in the same trade or occupation in the town in which such public works project is being constructed. State of Connecticut Prevailing Wages apply when the cost of a renovation project equals or exceeds One Hundred Thousand Dollars and new construction equals or exceeds Four Hundred Thousand Dollars.</p> <p>Each contractor who is awarded a contract on or after October 15, 2002 shall be subject to provisions of the Connecticut General Statutes, Section 31-53 as amended by Public Act 02-69, "An Act Concerning Annual Adjustments to Prevailing Wages."            Wage rates will be posted each July 1<sup>st</sup> on the Department of Labor website: <a href="http://www.ctdol.state.ct.us">www.ctdol.state.ct.us</a>.            Such prevailing wage adjustments will not be considered a basis for an annual contract</p>				

**INVITATION TO BID**  
 UCHC-4 Rev. 5/07  
 Previous Rev. 12/04

**Jennifer K. Kelley**  
*Purchasing Services Officer*

**860-679-1988**  
*Telephone Number*

**STATE OF CONNECTICUT**

**UNIVERSITY OF CONNECTICUT HEALTH CENTER**

**FACILITY CONTRACTS & LEASES**  
 263 Farmington Avenue, MC 4039  
 Farmington, CT 06032

**Proposal Schedule**

Page 5 of 5

Payment terms are net 30 days after receipt of invoice.  
 Any deviation may result in proposal rejection.  
 Bid prices shall include all transportation charges FOB  
 University of Connecticut Health Center.

**Bid Number:**  
 4-0015

**Delivery:**

<b>Terms:</b>	<b>Cash Discount:</b>	
	%	# Days

**Bidder Name:**

**SSN or FEIN #:**

Item no.	Description of commodity and/or services	Qty.	Unit	Unit Price	Total Price
	<p>amendment.</p> <p>A 10% Bid Bond is required with the bid submittal.</p> <p>A 100% Performance Bond and a 100% Labor and Material Bond shall be furnished by the bidder awarded the contract, and shall be in an amount of 100% of the contract price. Bidder awarded the contract shall have ten (10) days After Receipt of Order to submit bonds to the Director of Purchasing.</p> <p>Upon request, the bidder shall submit information including but not limited to, company financial status; list of completed projects for the current year beginning in January, and two (2) previous years; references from each completed project including owner name and phone number; and all other informational requests. Failure to provide such information shall lead to rejection of bid.</p> <p>No changes to these specifications are to be acknowledged without the written authority of the Department of Facility Contracts &amp; Leases.</p> <p>Project Manager:            Abu Saleh, Campus Planning            Tel: 860-679-6510            Email: <a href="mailto:saleh@uchc.edu">saleh@uchc.edu</a></p> <p>Direct all question <u>via email</u> to:            Jennifer Kelley, Purchasing Officer            Tel: 860-679-1988            Email: <a href="mailto:jkk1011@adp.uchc.edu">jkk1011@adp.uchc.edu</a></p>				

Project: CT Scanner Replacement At Uconn Health Center

**Minimum Rates and Classifications  
for Building Construction**

**B** 11638

**Connecticut Department of Labor  
Wage and Workplace Standards Division**

By virtue of the authority vested in the Labor Commissioner under provisions of Section 31-53 of the General Statutes of Connecticut, as amended, the following are declared to be the prevailing rates and welfare payments and will apply only where the contract is advertised for bid within 20 days of the date on which the rates are established. Any contractor or subcontractor not obligated by agreement to pay to the welfare and pension fund shall pay this amount to each employee as part of his/her hourly wages.

**Project Number** 08-050

**Project Town** Farmington

Project: CT Scanner Replacement At Uconn Health Center

**CLASSIFICATION**

	<b>Hourly Rate</b>	<b>Benefits</b>
1a) Asbestos Worker/Insulator (Includes application of insulating materials, protective coverings, coatings, & finishes to all types of mechanical systems; application of firestopping material for wall openings & penetrations in walls, floors, ceilings.	34.21	19.81
1b) Asbestos/Toxic Waste Removal Laborers: Asbestos removal and encapsulation (except its removal from mechanical systems which are not to be scrapped), toxic waste removers, blasters.**See Laborers Group 7**		
1c) Hazardous Material Handler: Includes preparation, wetting, stripping, removal, scrapping, vacuuming, bagging and disposing of all insulation materials, whether they contain asbestos or not, from mechanical systems.	20.50	10.30
2) Boilermaker	32.73	8.72 + 33%
3a) Bricklayer, Cement Mason, Cement Finishers, Plasterers, Stone Masons	31.60	18.98 + a
3b) Tile Setter	30.78	16.98

**As of: Tuesday, December 23, 2008**

Project: CT Scanner Replacement At Uconn Health Center

3c) Terrazzo Workers, Marble Setters 30.91 19.12

3d) Tile, Marble & Terrazzo Finishers 24.90 14.78

-----LABORERS-----

4) Group 1: Laborers, carpenter tenders, wrecking laborers, fire  
watchers. 23.25 14.00

4a) Group 2: Mortar mixers, plaster tenders, power buggy  
operators, powdermen, fireproofers/mixer/nozzleman. 23.50 14.00

4b) Group 3: Jackhammer operators, mason tenders. 23.75 14.00

4c) \*\*Group 4: Pipelayers (Installation of water, storm drainage or  
sewage lines outside of the building line with P6, P7 license) [If using  
this classification call the Labor Department for clarification] 24.10 14.00

4d) Group 5: Air track operators, Sand blasters. 24.00 14.00

4e) Group 6: Nuclear toxic waste removers, blasters. 26.25 14.00

4f) Group 7: Asbestos removal and encapsulation (except it's  
removal from mechanical systems which are not to be scrapped). 24.25 14.00

***As of: Tuesday, December 23, 2008***

Project: CT Scanner Replacement At Uconn Health Center

4g) Group 8: Bottom men on open air caisson, cylindrical work and boring crew.	23.75	14.00
4h) Group 9: Top men on open air caisson, cylindrical work and boring crew.	23.25	14.00
5) Carpenter, Acoustical Tile Worker, Concrete Form-Wood Builder, Floor Covering (Including Drywall Hanging), Modular-Furniture Systems Installers, Lathers, Piledrivers, Resilient Floor Layers.	27.90	16.96
5a) Millwrights	28.65	16.96
6) Electrical Worker, Cable Splicer (electric) (Trade License required: E1,2 L-5,6 C-5,6 T-1,2 L-1,2 V-1,2,7,8,9)	34.40	18.57
7a) Elevator Mechanic (Trade License required: R-1,2,5,6)	41.34	16.285+a+b
8) Glazier (Trade License required: FG-1,2)	31.43	14.00 + a
9) Ironworker, Ornamental, Reinforcing, Structural, and Precast Concrete Erection	31.80	23.18 + a
----OPERATORS----		
Group 1: Crane handling or erecting structural steel or stone, hoisting engineer 2 drums or over, front end loader (7 cubic yards or over); work boat 26 ft. and over.	33.05	16.90 + a

**As of: Tuesday, December 23, 2008**

Project: CT Scanner Replacement At Uconn Health Center

Group 2: Cranes (100 ton rate capacity and over); Excavator over 2 cubic yards; Piledriver (\$3.00 premium when operator controls hammer)	32.73	16.90 + a
Group 3: Excavator; Cranes (under 100 ton rated capacity), Gradall; Master Mechanic; Hoisting Engineer (all types of equipment where a drum and cable are used to hoist or drag material regardless of motive power of operation), Rubber Tire Excavator (Drott-1085	31.99	16.90 + a
Group 4: Trenching Machines; Lighter Derrick; Concrete Finishing Machine; CMI Machine or Similar; Koehring Loader (Skooper)	31.60	16.90 + a
Group 5: Specialty Railroad Equipment; Asphalt Spreader; Asphalt Reclaiming Machine; Line Grinder; Concrete Pumps; Drills with Self Contained Power Units; Boring Machine; Post Hole Digger; Auger; Pounder; Well Digger; Milling Machine (over 24" Mandrell)	31.01	16.90 + a
Group 5 continued: Side Boom; Combination Hoe and Loader; Directional Driller.	31.01	16.90 + a
Group 6: Front End Loader (3 up to 7 cubic yards); Bulldozer (rough grade dozer).	30.70	16.90 + a
Group 7: Asphalt roller, concrete saws and cutters (ride on types), vermeer concrete cutter, Stump Grinder; Scraper; Snooper; Skidder; Milling Machine (24" and under Mandrell).	30.36	16.90 + a
Group 8: Mechanic, grease truck operator, hydroblaster; barrier mover; power stone spreader; welding; work boat under 26 ft.; transfer machine.	29.96	16.90 + a
Group 9: Front end loader (under 3 cubic yards), skid steer loader regardless of attachments, (Bobcat or Similar): forklift, power chipper; landscape equipment (including Hydroseeder).	29.53	16.90 + a
Group 10: Vibratory hammer; ice machine; diesel and air, hammer, etc.	27.49	16.90 + a

**As of: Tuesday, December 23, 2008**



Project: CT Scanner Replacement At Uconn Health Center

Group 11: Conveyor, earth roller, power pavement breaker (whiphammer), robot demolition equipment. 27.49 16.90 + a

Group 12: Wellpoint operator. 27.43 16.90 + a

Group 13: Compressor battery operator. 26.85 16.90 + a

Group 14: Elevator operator; tow motor operator (solid tire no rough terrain). 25.71 16.90 + a

Group 15: Generator Operator; Compressor Operator; Pump Operator; Welding Machine Operator; Heater Operator. 25.30 16.90 + a

Group 16: Maintenance engineer. 24.65 16.90 + a

Group 17: Portable asphalt plant operator; portable crusher plant operator; portable concrete plant operator. 28.96 16.90 + a

Group 18: Power safety boat; vacuum truck; zim mixer; sweeper; (Minimum for any job requiring a CDL license). 26.54 16.90 + a

-----PAINTERS (Including Drywall Finishing)-----

10a) Brush, Roller 27.87 14.00

**As of: Tuesday, December 23, 2008**

Project: CT Scanner Replacement At Uconn Health Center

10b) Taper	28.62	14.00
10c) Paperhanger	28.37	14.00
10d) Red Label	28.37	14.00
10e) Blast and Spray	30.87	14.00
10f) Tanks, Tower, Swingstage	29.87	14.00
11) Plumber P-1,2,6,7,8,9 J-1,2,3,4 SP-1,2)	(Trade License required: 35.37	19.71
12) Post Digger, Well Digger, Pile Testing Machine	25.25	9.05 + a
13) Roofer (composition)	30.30	13.61
14) Roofer (slate & tile)	30.80	13.61
15) Sheetmetal Worker (Trade License required for HVAC and Ductwork: SM-1,SM-2,SM-3,SM-4,SM-5,SM-6)	30.57	24.50

**As of: Tuesday, December 23, 2008**

Project: CT Scanner Replacement At Uconn Health Center

16) Pipefitter (Including HVAC work) (Trade License required: S-1,2,3,4,5,6,7,8 B-1,2,3,4 D-1,2,3,4, G-1, G-2, G-8 & G-9)	35.37	19.71
-----TRUCK DRIVERS-----		
17a) 2 Axle	26.18	12.47 + a
17b) 3 Axle, 2 Axle Ready Mix	26.28	12.47 + a
17c) 3 Axle Ready Mix	26.33	12.47 + a
17d) 4 Axle, Heavy Duty Trailer up to 40 tons	26.38	12.47 + a
17e) 4 Axle Ready Mix	26.43	12.47 + a
17f) Heavy Duty Trailer (40 Tons and Over)	26.63	12.47 + a
17g) Specialized Earth Moving Equipment (Other Than Conventional Type on-the-Road Trucks and Semi-Trailers, Including Euclids)	26.43	12.47 + a
18) Sprinkler Fitter (Trade License required: F-1,2,3,4)	38.35	15.65 + a

**As of: Tuesday, December 23, 2008**

Project: CT Scanner Replacement At Uconn Health Center

***Welders: Rate for craft to which welding is incidental.***

***\*Note: Hazardous waste removal work receives additional \$1.25 per hour for truck drivers.***

***\*\*Note: Hazardous waste premium \$3.00 per hour over classified rate***

**Crane with 150 ft. boom (including jib) - \$1.50 extra**  
**Crane with 200 ft. boom (including jib) - \$2.50 extra**  
**Crane with 250 ft. boom (including jib) - \$5.00 extra**  
**Crane with 300 ft. boom (including jib) - \$7.00 extra**  
**Crane with 400 ft. boom (including jib) - \$10.00 extra**

**All classifications that indicate a percentage of the fringe benefits must be calculated at the percentage rate times the "base hourly rate".**

**Apprentices duly registered under the Commissioner of Labor's regulations on "Work Training Standards for Apprenticeship and Training Programs" Section 31-51-d-1 to 12, are allowed to be paid the appropriate percentage of the prevailing journeymen hourly base and the full fringe benefit rate, providing the work site ratio shall not be less than one full-time journey person instructing and supervising the work of each apprentice in a specific trade.**

*The Prevailing wage rates applicable to this project are subject to annual adjustments each July 1st for the duration of the project.*

*Each contractor shall pay the annual adjusted prevailing wage rate that is in effect each July 1st, as posted by the Department of Labor.*

*It is the contractor's responsibility to obtain the annual adjusted prevailing wage rate increases directly from the Department of Labor's website.*

*The annual adjustments will be posted on the Department of Labor's Web page: [www.ct.gov/dol](http://www.ct.gov/dol)*

*The Department of Labor will continue to issue the initial prevailing wage rate schedule to the Contracting Agency for the project.*

*All subsequent annual adjustments will be posted on our Web Site for contractor access.*

**As of: Tuesday, December 23, 2008**

Project: CT Scanner Replacement At Uconn Health Center

*Effective October 1, 2005 - Public Act 05-50: any person performing the work of any mechanic, laborer, or worker shall be paid prevailing wage*

**All Person who perform work ON SITE must be paid prevailing wage for the appropriate mechanic, laborer, or worker classification.**

**All certified payrolls must list the hours worked and wages paid to All Persons who perform work ON SITE regardless of their ownership i.e.: (Owners, Corporate Officers, LLC Members, Independent Contractors, et. al)**

**Reporting and payment of wages is required regardless of any contractual relationship alleged to exist between the contractor and such person.**

**Please direct any questions which you may have pertaining to classification of work and payment of prevailing wages to the Wage and Workplace Standards Division, telephone (860)263-6790.**

***As of:* Tuesday, December 23, 2008**

CONNECTICUT DEPARTMENT OF LABOR  
WAGE AND WORKPLACE STANDARDS DIVISION

**CONTRACTORS WAGE CERTIFICATION FORM**

I, \_\_\_\_\_ of \_\_\_\_\_  
Officer, Owner, Authorized Rep. Company Name

do hereby certify that the \_\_\_\_\_  
Company Name

\_\_\_\_\_  
Street

\_\_\_\_\_  
City

and all of its subcontractors will pay all workers on the

\_\_\_\_\_  
Project Name and Number

\_\_\_\_\_  
Street and City

the wages as listed in the schedule of prevailing rates required for such project (a copy of which is attached hereto).

\_\_\_\_\_  
Signed

Subscribed and sworn to before me this \_\_\_\_\_ day of \_\_\_\_\_, 2004.

\_\_\_\_\_  
Notary Public

 Return to:

Connecticut Department of Labor  
Wage & Workplace Standards Division  
200 Folly Brook Blvd.  
Wethersfield, CT 06109

November 29, 2006

**Notice**  
**To All Mason Contractors and Interested Parties**  
**Regarding Construction Pursuant to Section 31-53 of the**  
**Connecticut General Statutes (Prevailing Wage)**

The Connecticut Labor Department Wage and Workplace Standards Division is empowered to enforce the prevailing wage rates on projects covered by the above referenced statute.

Over the past few years the Division has withheld enforcement of the rate in effect for workers who operate a forklift on a prevailing wage rate project due to a potential jurisdictional dispute.

The rate listed in the schedules and in our Occupational Bulletin (see enclosed) has been as follows:

**Forklift Operator:**

- **Laborers (Group 4) Mason Tenders** - operates forklift solely to assist a mason to a maximum height of nine feet only.
- **Power Equipment Operator (Group 9)** - operates forklift to assist any trade and to assist a mason to a height over nine feet.

The U.S. Labor Department conducted a survey of rates in Connecticut but it has not been published and the rate in effect remains as outlined in the above Occupational Bulletin.

*Since this is a classification matter and not one of jurisdiction, effective January 1, 2007 the Connecticut Labor Department will enforce the rate on each schedule in accordance with our statutory authority.*

Your cooperation in filing appropriate and accurate certified payrolls is appreciated.

# Informational Bulletin

## *Occupational Classifications*

The Connecticut Department of Labor has the responsibility to properly determine “job classification” on prevailing wage projects covered under C.G.S. Section 31-53.

√ **Note:** *This information is intended to provide a sample of some occupational classifications for guidance purposes only. It is not an all-inclusive list of each occupation’s duties. This list is being provided only to highlight some areas where a contractor may be unclear regarding the proper classification.*

Below are additional clarifications of specific job duties performed for certain classifications:

### **Asbestos Insulator:**

- Handle, install, apply, fabricate, distribute, prepare, alter, repair, or dismantle heat and frost insulation, including penetration and fire stopping work on all penetration fire stop systems.

### **Carpenter:**

- Assembly and installation of modular furniture/furniture systems.  
[New] a. Free-standing furniture is not covered. This includes: student chairs, study top desks, book box desks, computer furniture, dictionary stand, atlas stand, wood shelving, two- position information access station, file cabinets, storage cabinets, tables, etc.
- Applies fire stopping materials on fire resistive joint systems only.
- Installation of insulated material of all types whether blown, nailed or attached in other ways to walls, ceilings and floors of buildings.
- Installation of curtain/window walls only where attached to wood or metal studs.

### **Cleaning Laborer:**

- The clean up of any construction debris and the general cleaning, including sweeping, wash down, mopping, wiping of the construction facility, washing, polishing, dusting, etc., prior to the issuance of a certificate of occupancy falls under the *Labor classification*.

### **Delivery Personnel: (Revised)**

- If delivery of supplies/building materials is to one common point and stockpiled there, prevailing wages are not required. If the delivery personnel are involved in the distribution of the material to multiple locations within the construction site then they would have to be paid prevailing wages for the type of work performed: laborer, equipment operator, electrician, ironworker, plumber, etc.
- An example of this would be where delivery of drywall is made to a building and the delivery personnel distribute the drywall from one “stockpile” location to further sub-locations on each floor. Distribution of material around a construction site is the job of a laborer/tradesman and not a delivery personnel.



**Electrician:**

- Installation or maintenance of telecommunication, LAN wiring or computer equipment.  
Low voltage wiring.

**Fork Lift Operator:**

- Laborers Group 4) Mason Tenders - operates forklift solely to assist a mason to a maximum height of nine (9) feet only.  
Power Equipment Operator Group 9 - operates forklift to assist any trade, and to assist a mason to a height over nine (9) feet.

**Glaziers:**

- Installs light metal sash, head sills, and 2-story aluminum storefronts.  
Installation of aluminum window walls and curtain walls is the “joint” work of the Glaziers and Ironworkers classification which requires either a blended rate or equal composite workforce.

**Ironworkers:**

- Handling, sorting, and installation of reinforcing steel (rebar).
- Installation of aluminum window walls and curtain walls is the “joint” work of the Glaziers and Ironworkers classification which requires either a blended rate or equal composite workforce. Insulated metal and insulated composite panels are still installed by the Ironworker.
- Metal bridge rail (traffic), metal bridge handrail, and decorative security fence installation.

**Insulator:**

- Installing fire stopping systems/materials for “Penetration Firestop Systems”: transit to cables, electrical conduits, insulated pipes, sprinkler pipe penetrations, ductwork behind radiation, electrical cable trays, fire rated pipe penetrations, natural polypropylene, HVAC ducts, plumbing bare metal, telephone and communication wires, and boiler room ceilings. Past practice using the applicable licensed trades, Plumber, Sheet Metal, Sprinkler Fitter, and Electrician, is not inconsistent with the Insulator classification and would be permitted.

**Lead Paint Removal:**

- Painter Rate -
  - 1) Removal of lead paint from bridges.
  - 2) Removal of lead paint as preparation of any surface to be repainted.
  - 3) Where removal is on a *Demolition* project prior to reconstruction.
- Laborer Rate-
  - 1) Removal of lead paint from any surface *NOT* to be repainted.
  - 2) Where removal is on a *TOTAL* Demolition project only.

**Roofers:**

- Preparation of surface, tear-off and/or removal of any type of roofing, and/or clean-up of any areas where a roof is to be relaid.

**Sheet Metal Worker:**

- Fabrication, handling, assembling, erecting, altering, repairing, etc. of coated metal material panels and composite metal material panels when used on building exteriors and interiors as soffits, fascia, louvers, partitions, wall panel siding, canopies, cornice, column covers, awnings, beam covers, cladding, sun shades, lighting troughs, spires, ornamental roofing, metal ceilings, mansards, copings, ornamental and ventilation hoods, vertical and horizontal siding panels, trim, etc. The sheet metal classification also applies to the vast variety of coated metal material panels and composite metal material panels that have evolved over the years as an alternative to conventional ferrous and non-ferrous metals like steel, iron, tin, copper, brass, bronze, aluminum, etc. Insulated metal and insulated composite panels are still installed by the Iron Worker. Fabrication, handling, assembling, erecting, altering, repairing, etc. of architectural metal roof, standing seam roof, composite metal roof, metal and composite bathroom/toilet partitions, aluminum gutters, metal and composite lockers and shelving, kitchen equipment, and walk-in coolers

**Truck Drivers:**

- Truck Drivers delivering asphalt are covered under prevailing wage while on the site and directly involved in the paving operation.
- Material men and deliverymen are not covered under prevailing wage as long as they are not directly involved in the construction process. If, they unload the material, they would then be covered by prevailing wage for the classification they are performing work in: laborer, equipment operator, etc.
- Hauling material off site is not covered provided they are not dumping it at a location outlined above.
- Driving a truck on site and moving equipment or materials on site would be considered covered work, as this is part of the construction process.

Any questions regarding the proper classification should be directed to the Contract Compliance Unit, Wage and Workplace Standards Division, Connecticut Department of Labor, 200 Folly Brook Blvd, Wethersfield, CT 06109 at (860)263-6543.

# **Informational Bulletin**

## **THE 10-HOUR OSHA CONSTRUCTION SAFETY AND HEALTH COURSE**

(applicable to public building contracts entered into *on or after July 1, 2007*, where the total cost of all work to be performed is at least \$100,000)

- (1) This requirement was created by Public Act No. 06-175, which is codified in Section 31-53b of the Connecticut General Statutes (pertaining to the prevailing wage statutes);
- (2) The course is required for public building construction contracts (projects funded in whole or in part by the state or any political subdivision of the state) entered into on or after July 1, 2007;
- (3) It is required of private employees (not state or municipal employees) and apprentices who perform manual labor for a general contractor or subcontractor on a public building project where the total cost of all work to be performed is at least \$100,000;
- (4) The ten-hour construction course pertains to the ten-hour Outreach Course conducted in accordance with federal OSHA Training Institute standards, and, for telecommunications workers, a ten-hour training course conducted in accordance with federal OSHA standard, 29 CFR 1910.268;
- (5) The internet website for the federal OSHA Training Institute is [http://www.osha.gov/fso/ote/training/edcenters/fact\\_sheet.html](http://www.osha.gov/fso/ote/training/edcenters/fact_sheet.html);
- (6) The statutory language leaves it to the contractor and its employees to determine who pays for the cost of the ten-hour Outreach Course;
- (7) Within 30 days of receiving a contract award, a general contractor must furnish proof to the Labor Commissioner that all employees and apprentices performing manual labor on the project will have completed such a course;
- (8) Proof of completion may be demonstrated through either: (a) the presentation of a *bona fide* student course completion card issued by the federal OSHA Training Institute; *or* (2) the presentation of documentation provided to an employee by a trainer certified by the Institute pending the actual issuance of the completion card;
- (9) Any card with an issuance date more than 5 years prior to the commencement date of the construction project shall not constitute proof of compliance;

- (10) Each employer shall affix a copy of the construction safety course completion card to the certified payroll submitted to the contracting agency in accordance with Conn. Gen. Stat. § 31-53(f) on which such employee's name first appears;
- (11) Any employee found to be in non-compliance shall be subject to removal from the worksite if such employee does not provide satisfactory proof of course completion to the Labor Commissioner by the fifteenth day after the date the employee is determined to be in noncompliance;
- (12) Any such employee who is determined to be in noncompliance may continue to work on a public building construction project for a maximum of fourteen consecutive calendar days while bringing his or her status into compliance;
- (13) The Labor Commissioner may make complaint to the prosecuting authorities regarding any employer or agent of the employer, or officer or agent of the corporation who files a false certified payroll with respect to the status of an employee who is performing manual labor on a public building construction project;
- (14) The statute provides the minimum standards required for the completion of a safety course by manual laborers on public construction contracts; any contractor can exceed these minimum requirements; and
- (15) Regulations clarifying the statute are currently in the regulatory process, and shall be posted on the CTDOL website as soon as they are adopted in final form.
- (16) Any questions regarding this statute may be directed to the Wage and Workplace Standards Division of the Connecticut Labor Department via the internet website of <http://www.ctdol.state.ct.us/wgwkstnd/wgemenu.htm>; or by telephone at (860)263-6790.

**THE ABOVE INFORMATION IS PROVIDED EXCLUSIVELY AS AN EDUCATIONAL RESOURCE, AND IS NOT INTENDED AS A SUBSTITUTE FOR LEGAL INTERPRETATIONS WHICH MAY ULTIMATELY ARISE CONCERNING THE CONSTRUCTION OF THE STATUTE OR THE REGULATIONS.**

*CONNECTICUT DEPARTMENT OF LABOR*  
*FOOTNOTES*

Please Note: If the "Benefits" listed on the schedule for the following occupations includes a letter(s) (+ a or + a+b for instance), refer to the information below.

Benefits to be paid at the appropriate prevailing wage rate for the listed occupation.

If the "Benefits" section for the occupation lists only a dollar amount, disregard the information below.

**Bricklayers, Cement Masons, Cement Finishers, Plasters, Stone Masons  
(BUILDING CONSTRUCTION)**

- a. Paid Holiday: If an employee works on Christmas Eve until noon he shall be paid for 8 hours
- b. Fringe contributions for cement masons (performing flatwork only) will receive one and one-half times fringe contributions for hours worked over eight hours per day.

**Bricklayers, Cement Masons, Cement Finishers, Plasters, Stone Masons  
(HEAVY AND HIGHWAY CONSTRUCTION)**

- a. Paid Holiday: If an employee works on Christmas Eve until noon he shall be paid for 8 hours

**Carpenters, Diver Tenders, Dockbuilders, Piledrivers  
(HEAVY AND HIGHWAY CONSTRUCTION)**

- a. Paid Holidays: Memorial Day, Independence Day, Labor Day, provided the employee works 3 days during the week of the holiday and the working day before and after the holiday, if scheduled.

**Electricians**

Fairfield County: West of the Five Mile River in Norwalk

- a. \$2.00 per hour not to exceed \$14.00 per day.

**Elevator Constructors: Mechanics**

- a. Paid Holidays: New Year's Day, Memorial Day, Independence Day, Labor Day, Thanksgiving Day, Christmas Day, plus the Friday after Thanksgiving
- b. Vacation: Employer contributes 8% of basic hourly rate for 5 years or more of service or 6% of basic hourly rate for 6 months to 5 years of service as vacation pay credit.

**Glaziers**

- a. Paid Holidays: Labor Day and Christmas Day.

**Power Equipment Operators  
(HEAVY AND HIGHWAY CONSTRUCTION & BUILDING CONSTRUCTION)**

- a. Paid Holidays: New Year's Day, Good Friday, Memorial day, Independence Day, Labor Day, Thanksgiving Day and Christmas Day, provided the employee works 3 days during the week in which the holiday falls, if scheduled, and if scheduled, the working day before and the working day after the holiday.

**Ironworkers**

- a. Paid Holidays: Last four working hours on Christmas Eve and New Year's eve are paid holidays, provided the employee has been on the employer's payroll for the five consecutive days prior to Christmas Eve and New Year's Eve.

**Laborers (Tunnel Construction)**

- a. Paid Holidays: New Year's Day, Memorial Day, Independence Day, Labor Day, Thanksgiving Day and Christmas Day. No employee shall be eligible for holiday pay when he fails, without cause, to work the regular work day preceding the holiday or the regular work day following the holiday.

**Roofers**

- a. Paid Holidays: July 4th and Labor Day, provided the employee is employed 15 days prior to the holiday; and Christmas Day, provided the employee has worked in a shop on or after December 11th.

**Sprinkler Fitters**

- a. Paid Holidays: Memorial Day, July 4th, Labor Day, Thanksgiving Day and Christmas Day, provided the employee has been in the employment of a such contractor 20 working days prior to any such holiday.

**Truck Drivers**

**(HEAVY & HIGHWAY CONSTRUCTION & BUILDING CONSTRUCTION)**

- a. Paid Holidays: New Year's Day, Memorial Day, Independence Day, Labor Day, Thanksgiving Day, Christmas day, and Good Friday, provided the employee has at least 31 days service and works the last scheduled day before and the first scheduled day after the holiday.

**Sec. 31-53b. Construction safety and health course. Proof of completion required for employees on public building projects. Enforcement. Regulations.** (a) Each contract entered into on or after July 1, 2007, for the construction, remodeling, refinishing, refurbishing, rehabilitation, alteration or repair of any public building project by the state or any of its agents, or by an political subdivision of the state or any of its agents, where the total cost of all work to be performed by all contractors and subcontractors in connection with the contract is at least one hundred thousand dollars, shall contain a provision requiring that, not later than thirty days after the date such contract is awarded, each contractor furnish proof to the Labor Commissioner that all employees performing manual labor on or in such public building, pursuant to such contract, have completed a course of at least ten hours in duration in construction safety and health approved by the federal Occupational Safety and Health Administration or, in the case of telecommunications employees, have completed at least ten hours of training in accordance with 29 CFR 1910.268.

(b) Any employee required to complete a construction safety and health course required under subsection (a) of this section who has not completed the course shall be subject to removal from the worksite if the employee does not provide documentation of having completed such course by the fifteenth day after the date the employee is found to be in noncompliance. The Labor Commissioner or said commissioner's designee shall enforce this section.

(c) Not later than January 1, 2007, the Labor Commissioner shall adopt regulations, in accordance with the provisions of chapter 54, to implement the provisions of subsections (a) and (b) of this section. Such regulations shall require that the ten-hour construction safety and health courses required under subsection (a) of this section be conducted in accordance with federal Occupational Safety and Health Administration Training Institute standards, or in accordance with 29 CFR 1910.268, as appropriate. The Labor Commissioner shall accept as sufficient proof of compliance with the provisions of subsection (a) or (b) of this section a student course completion card issued by the federal Occupational Safety and Health Administration Training Institute, or such other proof of compliance said commissioner deems appropriate, dated no earlier than five years before the commencement date of such public works project.

(d) For the purposes of this section, "public building" means a structure, paid for in whole or in part with state funds, within a roof and within exterior walls or fire walls, designed for the housing, shelter, enclosure and support or employment of people, animals or property of any kind, including, but not limited to, sewage treatment plants and water treatment plants, "Public building" does not include site work, roads or bridges, rail lines, parking lots or underground water, sewer or drainage systems including pump houses or other utility systems.



INVITATION TO BID  
UCHC-5

**STATE OF CONNECTICUT**  
**UNIVERSITY OF CONNECTICUT HEALTH CENTER**  
**FACILITY CONTRACTS & LEASES**

THIS FORM AND  
REQUIRED PROPOSAL  
SCHEDULE FORMS  
MUST BE RETURNED

Jennifer K. Kelley

*Purchasing Services Officer*

263 Farmington Avenue, MC 4039

Farmington, CT 06032

**Read & Complete**

**Carefully**

860-679-1988

Telephone Number

**BID NO: 4-0015**

**COMMISSION ON HUMAN RIGHTS AND OPPORTUNITIES**  
**CONTRACT COMPLIANCE REGULATIONS**  
**NOTIFICATION TO BIDDERS**

(Revised 9-17-07)

The contract to be awarded is subject to contract compliance requirements mandated by Sections 4a-60 and 4a-60a of the Connecticut General Statutes; and, when the awarding agency is the State, Sections 46a-71(d) and 46a-81i(d) of the Connecticut General Statutes. There are Contract Compliance Regulations codified at Section 46a-68j-21 through 43 of the Regulations of Connecticut State Agencies, which establish a procedure for awarding all contracts covered by Sections 4a-60 and 46a-71(d) of the Connecticut General Statutes.

According to Section 46a-68j-30(9) of the Contract Compliance Regulations, every agency awarding a contract subject to the contract compliance requirements has an obligation to “aggressively solicit the participation of legitimate minority business enterprises as bidders, contractors, subcontractors and suppliers of materials.” “Minority business enterprise” is defined in Section 4a-60 of the Connecticut General Statutes as a business wherein fifty-one percent or more of the capital stock, or assets belong to a person or persons: “(1) Who are active in daily affairs of the enterprise; (2) who have the power to direct the management and policies of the enterprise; and (3) who are members of a minority, as such term is defined in subsection (a) of Section 32-9n.” “Minority” groups are defined in Section 32-9n of the Connecticut General Statutes as “(1) Black Americans . . . (2) Hispanic Americans . . . (3) persons who have origins in the Iberian Peninsula . . . (4) Women . . . (5) Asian Pacific Americans and Pacific Islanders; (6) American Indians . . .” An individual with a disability is also a minority business enterprise as provided by Section 4a-60g of the Connecticut General Statutes. The above definitions apply to the contract compliance requirements by virtue of Section 46a-68j-21(11) of the Contract Compliance Regulations.

The awarding agency will consider the following factors when reviewing the bidder’s qualifications under the contract compliance requirements:

- (a) the bidder’s success in implementing an affirmative action plan;
  - (b) the bidder’s success in developing an apprenticeship program complying with Sections 46a-68-1 to 46a-68-17 of the Administrative Regulations of Connecticut State Agencies, inclusive;
  - (c) the bidder’s promise to develop and implement a successful affirmative action plan;
  - (d) the bidder’s submission of employment statistics contained in the “Employment Information Form”, indicating that the composition of its workforce is at or near parity when compared to the racial and sexual composition of the workforce in the relevant labor market area; and
  - (e) the bidder’s promise to set aside a portion of the contract for legitimate minority business enterprises. See Section 46a-68j-30(10)(E) of the Contract Compliance Regulations.
-

## **INSTRUCTIONS AND OTHER INFORMATION**

The following BIDDER CONTRACT COMPLIANCE MONITORING REPORT must be completed in full, signed, and submitted with the bid for this contract. The contract awarding agency and the Commission on Human Rights and Opportunities will use the information contained thereon to determine the bidders compliance to Sections 4a-60 and 4a-60a CONN. GEN. STAT., and Sections 46a-68j-23 of the Regulations of Connecticut State Agencies regarding equal employment opportunity, and the bidder's good faith efforts to include minority business enterprises as subcontractors and suppliers for the work of the contract.

### **1) Definition of Small and Minority-Owned Contractor**

Section 4a-60g CONN. GEN. STAT. defines a small contractor as a company that has been doing business under the same management and control and has maintained its principal place of business in Connecticut for a one year period immediately prior to its application for certification under this section, had gross revenues not exceeding ten million dollars in the most recently completed fiscal year, and at least fifty-one percent of the ownership of which is held by a person or persons who are active in the daily affairs of the company, and have the power to direct the management and policies of the company, except that a nonprofit corporation shall be construed to be a small contractor if such nonprofit corporation meets the requirements of subparagraphs (A) and (B) of subdivision 4a-60g CONN. GEN. STAT.

## 2) Description of Job Categories (as used in Part IV Bidder Employment Information)

<p><b>MANAGEMENT:</b> Managers plan, organize, direct, and control the major functions of an organization through subordinates who are at the managerial or supervisory level. They make policy decisions and set objectives for the company or departments. They are not usually directly involved in production or providing services. Examples include top executives, public relations managers, managers of operations specialties (such as financial, human resources, or purchasing managers), and construction and engineering managers.</p> <p><b>BUSINESS AND FINANCIAL OPERATIONS:</b> These occupations include managers and professionals who work with the financial aspects of the business. These occupations include accountants and auditors, purchasing agents, management analysts, labor relations specialists, and budget, credit, and financial analysts.</p> <p><b>MARKETING AND SALES:</b> Occupations related to the act or process of buying and selling products and/or services such as sales engineer, retail sales workers and sales representatives including wholesale.</p> <p><b>LEGAL OCCUPATIONS:</b> In-House Counsel who is charged with providing legal advice and services in regards to legal issues that may arise during the course of standard business practices. This category also includes assistive legal occupations such as paralegals, legal assistants.</p> <p><b>COMPUTER SPECIALISTS:</b> Professionals responsible for the computer operations within a company are grouped in this category. Examples of job titles in this category include computer programmers, software engineers, database administrators, computer scientists, systems analysts, and computer support specialists</p> <p><b>ARCHITECTURE AND ENGINEERING:</b> Occupations related to architecture, surveying, engineering, and drafting are included in this category. Some of the job titles in this category include electrical and electronic engineers, surveyors, architects, drafters, mechanical engineers, materials engineers, mapping technicians, and civil engineers.</p> <p><b>OFFICE AND ADMINISTRATIVE SUPPORT:</b> All clerical-type work is included in this category. These jobs involve the preparing, transcribing, and preserving of written communications and records; collecting accounts; gathering and distributing information; operating office machines and electronic data processing equipment; and distributing mail. Job titles listed in this category include telephone operators, bill and account collectors, customer service representatives, dispatchers, secretaries and administrative assistants, computer operators and clerks (such as payroll, shipping, stock, mail and file).</p>	<p><b>BUILDING AND GROUNDS CLEANING AND MAINTENANCE:</b> This category includes occupations involving landscaping, housekeeping, and janitorial services. Job titles found in this category include supervisors of landscaping or housekeeping, janitors, maids, grounds maintenance workers, and pest control workers.</p> <p><b>CONSTRUCTION AND EXTRACTION:</b> This category includes construction trades and related occupations. Job titles found in this category include boilermakers, masons (all types), carpenters, construction laborers, electricians, plumbers (and related trades), roofers, sheet metal workers, elevator installers, hazardous materials removal workers, paperhangers, and painters. Paving, surfacing, and tamping equipment operators; drywall and ceiling tile installers; and carpet, floor and tile installers and finishers are also included in this category. First line supervisors, foremen, and helpers in these trades are also grouped in this category..</p> <p><b>INSTALLATION, MAINTENANCE AND REPAIR:</b> Occupations involving the installation, maintenance, and repair of equipment are included in this group. Examples of job titles found here are heating, ac, and refrigeration mechanics and installers; telecommunication line installers and repairers; heavy vehicle and mobile equipment service technicians and mechanics; small engine mechanics; security and fire alarm systems installers; electric/electronic repair, industrial, utility and transportation equipment; millwrights; riggers; and manufactured building and mobile home installers. First line supervisors, foremen, and helpers for these jobs are also included in the category.</p> <p><b>MATERIAL MOVING WORKERS:</b> The job titles included in this group are Crane and tower operators; dredge, excavating, and lading machine operators; hoist and winch operators; industrial truck and tractor operators; cleaners of vehicles and equipment; laborers and freight, stock, and material movers, hand; machine feeders and offbearers; packers and packagers, hand; pumping station operators; refuse and recyclable material collectors; and miscellaneous material moving workers.</p> <p><b>PRODUCTION WORKERS:</b> The job titles included in this category are chemical production machine setters, operators and tenders; crushing/grinding workers; cutting workers; inspectors, testers sorters, samplers, weighers; precious stone/metal workers; painting workers; cementing/gluing machine operators and tenders; etchers/engravers; molders, shapers and casters except for metal and plastic; and production workers.</p>
--	---

3) Definition of Racial and Ethnic Terms (as used in Part IV Bidder Employment Information)

<p><u>White</u> (not of Hispanic Origin)- All persons having origins in any of the original peoples of Europe, North Africa, or the Middle East.</p> <p><u>Black</u> (not of Hispanic Origin)- All persons having origins in any of the Black racial groups of Africa.</p> <p><u>Hispanic</u>- All persons of Mexican, Puerto Rican, Cuban, Central or South American, or other Spanish culture or origin, regardless of race.</p>	<p><u>Asian or Pacific Islander</u>- All persons having origins in any of the original peoples of the Far East, Southeast Asia, the Indian subcontinent, or the Pacific Islands. This area includes China, India, Japan, Korea, the Philippine Islands, and Samoa.</p> <p><u>American Indian or Alaskan Native</u>- All persons having origins in any of the original peoples of North America, and who maintain cultural identification through tribal affiliation or community recognition.</p>
--	---

# BIDDER CONTRACT COMPLIANCE MONITORING REPORT

## PART I - Bidder Information

**Bid No. 4-0015**

Company Name: Street Address: City & State: Chief Executive:	Bidder Federal Employer Identification Number: Or Social Security Number:
Major Business Activity (brief description)	Bidder Identification (response optional/definitions on page 1)  -Bidder is a small contractor: Yes <input type="checkbox"/> No <input type="checkbox"/> -Bidder is a minority business enterprise: Yes <input type="checkbox"/> No <input type="checkbox"/> (If yes, check ownership category) Black <input type="checkbox"/> Hispanic <input type="checkbox"/> Asian American <input type="checkbox"/> American Indian/Alaskan Native <input type="checkbox"/> Iberian Peninsula <input type="checkbox"/> Individual(s) with a Physical Disability: <input type="checkbox"/> Female: <input type="checkbox"/>
Bidder Parent Company (If any)	- Bidder is certified as above by State of CT Yes <input type="checkbox"/> No <input type="checkbox"/>
Other Locations in Ct. (If any)	- DAS Certification Number:

## PART II - Bidder Nondiscrimination Policies and Procedures

1. Does your company have a written Affirmative Action/Equal Employment Opportunity statement posted on company bulletin boards? Yes <input type="checkbox"/> No <input type="checkbox"/>	7. Do all of your company contracts and purchase orders contain non-discrimination statements as required by Sections 4a-60 & 4a-60a Conn. Gen. Stat.? Yes <input type="checkbox"/> No <input type="checkbox"/>
2. Does your company have the state-mandated sexual harassment prevention in the workplace policy posted on company bulletin boards? Yes <input type="checkbox"/> No <input type="checkbox"/>	8. Do you, upon request, provide reasonable accommodation to employees, or applicants for employment, who have physical or mental disability? Yes <input type="checkbox"/> No <input type="checkbox"/>
3. Do you notify all recruitment sources in writing of your company's Affirmative Action/Equal Employment Opportunity employment policy? Yes <input type="checkbox"/> No <input type="checkbox"/>	9. Does your company have a mandatory retirement age for all employees? Yes <input type="checkbox"/> No <input type="checkbox"/>
4. Do your company advertisements contain a written statement that you are an Affirmative Action/Equal Opportunity Employer? Yes <input type="checkbox"/> No <input type="checkbox"/>	10. If your company has 50 or more employees, have you provided at least two (2) hours of sexual harassment training to all of your supervisors? Yes <input type="checkbox"/> No <input type="checkbox"/> NA <input type="checkbox"/>
5. Do you notify the Ct. State Employment Service of all employment openings with your company? Yes <input type="checkbox"/> No <input type="checkbox"/>	11. If your company has apprenticeship programs, do they meet the Affirmative Action/Equal Employment Opportunity requirements of the apprenticeship standards of the Ct. Dept. of Labor? Yes <input type="checkbox"/> No <input type="checkbox"/> NA <input type="checkbox"/>
6. Does your company have a collective bargaining agreement with workers? Yes <input type="checkbox"/> No <input type="checkbox"/> 6a. If yes, do the collective bargaining agreements contain non-discrimination clauses covering all workers? Yes <input type="checkbox"/> No <input type="checkbox"/> 6b. Have you notified each union in writing of your commitments under the nondiscrimination requirements of contracts with the state of Ct? Yes <input type="checkbox"/> No <input type="checkbox"/>	12. Does your company have a written affirmative action Plan? Yes <input type="checkbox"/> No <input type="checkbox"/> If no, please explain. 13. Is there a person in your company who is responsible for equal employment opportunity? Yes <input type="checkbox"/> No <input type="checkbox"/> If yes, give name and phone number. _____

## Part III - Bidder Subcontracting Practices

1. Will the work of this contract include subcontractors or suppliers? Yes <input type="checkbox"/> No <input type="checkbox"/>	
1a. If yes, please list all subcontractors and suppliers and report if they are a small contractor and/or a minority business enterprise. (defined on page 1 / use additional sheet if necessary)	
1b. Will the work of this contract require additional subcontractors or suppliers other than those identified in 1a. above?	Yes <input type="checkbox"/> No <input type="checkbox"/>

**PART IV - Bidder Employment Information**

Date:

**BID No.: 4-0015**

JOB CATEGORY *	OVERALL TOTALS	WHITE (not of Hispanic origin)		BLACK (not of Hispanic origin)		HISPANIC		ASIAN or PACIFIC ISLANDER		AMERICAN INDIAN or ALASKAN NATIVE	
		Male	Female	Male	Female	Male	Female	Male	Female	male	Female
Management											
Business & Financial Ops											
Marketing & Sales											
Legal Occupations											
Computer Specialists											
Architecture/Engineering											
Office & Admin Support											
Bldg/ Grounds Cleaning/Maintenance											
Construction & Extraction											
Installation , Maintenance & Repair											
Material Moving Workers											
Production Occupations											
TOTALS ABOVE											
Total One Year Ago											
FORMAL ON THE JOB TRAINEES (ENTER FIGURES FOR THE SAME CATEGORIES AS ARE SHOWN ABOVE)											
Apprentices											
Trainees											

\*NOTE: JOB CATEGORIES CAN BE CHANGED OR ADDED TO (EX. SALES CAN BE ADDED OR REPLACE A CATEGORY NOT USED IN YOUR COMPANY)

**PART V - Bidder Hiring and Recruitment Practices**

1. Which of the following recruitment sources are used by you? (Check yes or no, and report percent used)				2. Check (X) any of the below listed requirements that you use as a hiring qualification (X)		3. Describe below any other practices or actions that you take which show that you hire, train, and promote employees without discrimination
SOURCE	YES	NO	% of applicants provided by source			
State Employment Service	<input type="checkbox"/>	<input type="checkbox"/>		<input type="checkbox"/>	Work Experience	
Private Employment Agencies	<input type="checkbox"/>	<input type="checkbox"/>		<input type="checkbox"/>	Ability to Speak or Write English	
Schools and Colleges	<input type="checkbox"/>	<input type="checkbox"/>		<input type="checkbox"/>	Written Tests	
Newspaper Advertisement	<input type="checkbox"/>	<input type="checkbox"/>		<input type="checkbox"/>	High School Diploma	
Walk Ins	<input type="checkbox"/>	<input type="checkbox"/>		<input type="checkbox"/>	College Degree	
Present Employees	<input type="checkbox"/>	<input type="checkbox"/>		<input type="checkbox"/>	Union Membership	
Labor Organizations	<input type="checkbox"/>	<input type="checkbox"/>		<input type="checkbox"/>	Personal Recommendation	
Minority/Community Organizations	<input type="checkbox"/>	<input type="checkbox"/>		<input type="checkbox"/>	Height or Weight	
Others (please identify)	<input type="checkbox"/>	<input type="checkbox"/>		<input type="checkbox"/>	Car Ownership	
	<input type="checkbox"/>	<input type="checkbox"/>		<input type="checkbox"/>	Arrest Record	
	<input type="checkbox"/>	<input type="checkbox"/>		<input type="checkbox"/>	Wage Garnishments	

**Certification:** (Read this form and check your statements on it CAREFULLY before signing). I certify that the statements made by me on this BIDDER CONTRACT COMPLIANCE MONITORING REPORT are complete and true to the best of my knowledge and belief, and are made in good faith. I understand that if I knowingly make any misstatements of facts, I am subject to be declared in non-compliance with Section 4a-60, 4a-60a, and related sections of the CONN. GEN. STAT.

(Signature)	(Title)	(Date Signed)	(Telephone)
-------------	---------	---------------	-------------

**INVITATION TO BID**

UCHC-6 Rev. 8/07

Previous Rev. 5/07

**Jennifer K. Kelley**

*Purchasing Services Officer*

**860-679-1988**

Telephone Number

**STATE OF CONNECTICUT**  
**UNIVERSITY OF CONNECTICUT HEALTH CENTER**  
**FACILITY CONTRACTS & LEASES**

263 Farmington Avenue, MC 4039

Farmington, CT 06032

<b>Bid Number:</b>  4-0015
----------------------------------

**State of Connecticut**  
**Contract Affidavits, Certifications, and Notices**

WHEN TO SUBMIT	CONTRACTING AFFIDAVITS/CERTIFICATION FORMS			
	Signed by AGENCY	Signed by CONTRACTOR		
		ALL Contracts	All Contracts Cost or value ≥ \$50K	All Contracts Cost or value ≥ \$500K
submit form <b>with</b> bid or proposal		AG FORM (Individual or Contractor)	FORM 5*	FORM 6 **
submit form <b>at time of</b> contract execution	FORM 3	AG FORM (Individual or Contractor)	FORM 1 FORM 5*	FORM 6 **
submit form <b>after</b> contract execution				FORM 6 **
submit form <b>annually</b> if multi-year contract			FORM 1	

\* Form 5 is normally submitted by the contractor to the awarding State agency with the bid or proposal. However, for a sole source or no bid contract, it is submitted at the time of contract execution.

\*\* Form 6 is normally submitted by the contractor to the awarding State agency with the bid or proposal. However, for a sole source or no bid contract, Form 6 is submitted at the time of contract execution. When applicable, Form 6 is also used by a subcontractor or consultant of the contractor. The subcontractor or consultant submits the form to the contractor, who then submits it to the awarding State agency. Depending on when the contractor engages the subcontractor or consultant, the contractor either submits the form at the time of contract execution or after contract execution.

**For Further Information, Contact:**

Please direct any questions about the ethics forms to Wanda Dupuy, (860) 418-6261, [wanda.dupuy@ct.gov](mailto:wanda.dupuy@ct.gov).

**Form 1- Gift and Campaign Contribution Certification**

This certification accompanies a State contract with a value of \$50,000 or more in a calendar or fiscal year. The completed form is submitted by the contractor to the awarding State agency at the time of contract execution. The form is also used with a multi-year contract to update the initial certification on an annual basis.

**Form 3- Certification of State Agency Official or Employee Authorized to Execute Contract**

This certification accompanies a State contract with a value of \$50,000 or more in a calendar or fiscal year. The completed form is signed at the time of contract execution by the State agency official or employee authorized to execute the contract on behalf of the awarding State agency.

### **Form 5- Consulting Agreement Affidavit**

This affidavit accompanies a State contract for the purchase of goods or services with a value of \$50,000 or more in a calendar or fiscal year. Form 5 is normally submitted by the contractor to the awarding State agency with the bid or proposal. However, for a sole source or no bid contract, it is submitted at the time of contract execution.

### **Form 6- Affirmation of Receipt of State Ethics Laws Summary**

This affirmation accompanies a large State construction contract or a large State procurement contract with a cost of more than \$500,000. Form 6 is normally submitted by the contractor to the awarding State agency with the bid or proposal. However, for a sole source or no bid contract, Form 6 is submitted at the time of contract execution.

When applicable, Form 6 is also used by a subcontractor or consultant of the contractor. The subcontractor or consultant submits the form to the contractor, who then submits it to the awarding State agency.

## **PLAIN LANGUAGE SUMMARY OF STATE ETHICS LAWS FOR CURRENT AND POTENTIAL STATE CONTRACTORS**

Note: The following is a summary of the major ethics laws and related provisions applicable to current and potential state contractors. For more detailed information or to discuss any questions you may have, contact the Office of State Ethics at (860) 566-4472.

### **I. RESTRICTIONS ON THE BENEFITS YOU MAY GIVE TO STATE PERSONNEL**

**GIFTS:** In general, no one doing business with or seeking business from a state or quasi-public agency may give a gift to an official or employee of that agency. Connecticut's gift ban is strict, but has some exceptions. For example, under the Ethics Code, you may give: (1) food and drink up to \$50 per person per year, if the person paying, or his or her representative, is in attendance; and (2) tangible gifts up to \$10 per item up to \$50 per person per year. Also exempt are certain items such as informational materials, or plaques costing less than \$100. For a complete list of the Code's gift exceptions, consult Conn. Gen. Stat. § 1-79(e) or contact the Office of State Ethics.

**IMPORTANT RECENT CHANGE IN LAW:** As of July 1, 2004, gifts for "major life events," including a wedding or the birth of a child, which were previously exempt from the gift ban, are now subject to the strict gift limits outlined above if the gifts are provided by any individual or entity doing business with or seeking business from the state.

**NOTE:** State agencies may have stricter gift rules than the provisions of the Ethics Code (for example, an agency policy may ban all food and drink). Be sure to obtain a copy of the agency's ethics policy before you provide any benefit to an agency official/employee.

**NECESSARY EXPENSES:** Under the Ethics Code, you may not pay a fee or an honorarium to a state official or employee for making a speech or appearing at your organization's event. You may, however, under limited circumstances, pay the "necessary expenses" of such a state servant. These expenses are limited to: necessary travel, lodging for the nights before, or and after the speech, meals and conference fees. There may be reporting requirements attached to the giving and taking of necessary expenses, so contact the Office of State Ethics if you need more information. **NOTE:** Before providing necessary expenses, check with the state agency's ethics officer to determine if the agency allows such payments.

**GIFTS TO THE STATE:** The Ethics Code allows limited "gifts to the state" which facilitate state action or functions (for example, donating a piece of equipment to the agency).

**NOTE:** Recent legislation was passed that may impact gifts to the state. Please contact the Office of State Ethics before giving a gift to the state to determine if such donations are acceptable.

### **II. RULES ON HIRING STATE PERSONNEL**

Before you hire a current or former state employee, you should be aware of certain provisions of the Ethics Code. First, if you are considering hiring a current state employee, especially from a state agency with which you do business or by which you are regulated, you should know the following:

A current state employee must not accept outside employment that impairs his independence of judgment regarding his state duties, or that encourages him to disclose confidential information learned in his state job. Also, a current state employee may not use his or her state position for financial gain, however inadvertent that use may be. Therefore, for example, a current state employee who exercises any contractual, supervisory or regulatory authority over you or your business may not be able to work for you.

Second, if you are considering hiring a former state employee, you should be aware of the Ethics Code's post-state employment, or revolving door, laws:

If you hire or otherwise engage the services of a former state official or employee, he or she may not represent you before his or her former agency for one year after leaving state service.

**NOTE:** The former State Ethics Commission established a limited exception to this provision which allows the former employee to return to his or her former agency within the one year period for the sole purpose of providing technical expertise (for example, to help implement a previously awarded contract). This is a fact-specific exception that applies in very limited circumstances: therefore, you should contact the Office of State Ethics for further assistance if you think this exception applies to you.

If a state official or employee was substantially involved in, or supervised, the negotiation or award of a contract valued at



\$50,000 or more, and the contract was signed within his or her last year of state service, and you or your business was one of the parties to the contract, then you and/or your business are prohibited from hiring him or her for one year after he or she leaves state employment.

A former state official or employee can never represent anyone other than the state regarding a particular matter in which he or she was personally and substantially involved while in state service and in which the state has a substantial interest.

Third, there are approximately 75 state officials or employees who may not negotiate for, seek or accept employment with any business subject to regulation by their agency, and may not accept employment with such a business for one year after leaving state service. Under that section of the law, it is also illegal for a business in the industry to employ such an individual.

### **III. CONFLICT OF INTEREST RULES THAT APPLY TO YOU AS A STATE CONTRACTOR**

Under Conn. Gen. Stat. §1-86e of the Ethics Code, no state contractor, including a consultant or other independent contractor, can use the authority provided under the contract, or confidential information acquired in the performance of the contract, to obtain financial gain for himself, his employee, or a member of his immediate family. Also, a state contractor cannot accept another state contract that would impair his independence of judgment in the performance of the first contract. Finally, a state contractor cannot accept anything of value based on an understanding that his actions on behalf of the state would be influenced.

It is important to call the Office of State Ethics at (860) 566-4472 to discuss the application of this law, or any of the other ethics laws, to your specific situation.

### **IV. OTHER ETHICS PROVISIONS THAT MAY APPLY TO YOU**

Contractors seeking large state contracts are required to execute affidavits regarding gifts and/or campaign contributions made to certain state employees or public officials in the two-year period prior to the submission of a bid or proposal. You need to check the web sites of both the Department of Administrative Services, [www.das.state.ct.us](http://www.das.state.ct.us), and the Office of Policy and Management, [www.opm.state.ct.us](http://www.opm.state.ct.us), for copies of these affidavits and for other updated information regarding state contractors. Also, because the particular agency with which you wish to contract may have specific rules that you must follow, you need to check with that agency as well.

If you or your business provides “investment services” as defined in the Code of Ethics, and you make a political contribution in connection with the Office of the Treasurer, you may be prohibited from contracting with that office. See Conn. Gen. Stat. § 1-84(n).

Finally, if you or your business spends or receives \$2,000 or more in a calendar year for activities that constitute lobbying under the Ethics Code, whether to affect legislation or the actions of an administrative state agency, then you and/or your business may have to register as a lobbyist with the Office of State Ethics, and more ethics rules will apply to you. Contact the Office of State Ethics, or review the lobbyist registration information at [www.ct.gov/ethics](http://www.ct.gov/ethics).

Recent legislation (Public Act 05-287) prohibits anyone who is a party (or who is seeking to become a party) to a state construction, procurement, or consultant services contract over \$500,000 from:

- (1) Soliciting information from a public official or state employee that is not available to other bidders for that contract, with the intent to obtain a competitive advantage over other bidders;
- (2) intentionally or recklessly charging a state agency for work not performed or goods or services not provided, or falsifying invoices or bills; or
- (3) intentionally violating or trying to circumvent the state competitive bidding and ethics laws.

Recent legislation (Public Act 05-287) also requires any prospective state contractor to affirm in writing that he or she has been provided with a summary of the state’s ethics laws and that his key employees have read and understood the summary and agree to comply with the applicable provisions of the ethics law.

### **FORM 11 Campaign Contribution and Solicitation Ban**

No state contractor, prospective state contractor, principal of a state contractor or principal of a prospective state contractor, with regard to a state contract or state contract solicitation with or from a state agency in the executive branch or a quasi-public agency or a holder, or principal of a holder of a valid prequalification certificate, shall make a contribution to, or solicit contributions on behalf of (i) an exploratory committee or candidate committee established by a candidate for nomination or election to the office of Governor, Lieutenant Governor, Attorney General, State Comptroller, Secretary of the State or State Treasurer, (ii) a political committee authorized to make contributions or expenditures to or for the benefit of such candidates, or (iii) a party committee;

In addition, no holder or principal of a holder of a valid prequalification certificate, shall make a contribution to, or solicit contributions on behalf of (i) an exploratory committee or candidate committee established by a candidate for nomination or election to the office of State senator or State representative, (ii) a political committee authorized to make contributions or expenditures to or for the benefit of such candidates, or (iii) a party committee.

## **Nondiscrimination Certification (AG Form)**

The Office of the Attorney General created a nondiscrimination certification form (attached) to assist State agencies in complying with the State of Connecticut's current contracting requirement, pursuant to the Connecticut General Statutes § 4a-60(a)(1) and § 4a-60a(a)(1), as amended by Public Act 07-245 and Section 9(a)(1) and 10(a)(1) of Public Act 07-142. This certification is required for all State contracts, regardless of type, term, cost, or value. The revised CGS 4a-60 and 40-60a are included in their entirety below.

### **Sec. 4a-60. (Formerly Sec. 4-114a). Nondiscrimination and affirmative action provisions in contracts of the state and political subdivisions other than municipalities.**

- (a) Every contract to which the state or any political subdivision of the state other than a municipality is a party shall contain the following provisions: (1) The contractor agrees and warrants that in the performance of the contract such contractor will not discriminate or permit discrimination against any person or group of persons on the grounds of race, color, religious creed, age, marital status, national origin, ancestry, sex, mental retardation or physical disability, including, but not limited to, blindness, unless it is shown by such contractor that such disability prevents performance of the work involved, in any manner prohibited by the laws of the United States or of the state of Connecticut. The contractor further agrees to take affirmative action to insure that applicants with job-related qualifications are employed and that employees are treated when employed without regard to their race, color, religious creed, age, marital status, national origin, ancestry, sex, mental retardation, or physical disability, including, but not limited to, blindness, unless it is shown by such contractor that such disability prevents performance of the work involved; (2) the contractor agrees, in all solicitations or advertisements for employees placed by or on behalf of the contractor, to state that it is an "affirmative action-equal opportunity employer" in accordance with regulations adopted by the commission; (3) the contractor agrees to provide each labor union or representative of workers with which such contractor has a collective bargaining agreement or other contract or understanding and each vendor with which such contractor has a contract or understanding, a notice to be provided by the commission advising the labor union or workers' representative of the contractor's commitments under this section, and to post copies of the notice in conspicuous places available to employees and applicants for employment; (4) the contractor agrees to comply with each provision of this section and sections 46a-68e and 46a-68f and with each regulation or relevant order issued by said commission pursuant to sections 46a-56, as amended by this act, 46a-68e and 46a-68f; (5) the contractor agrees to provide the Commission on Human Rights and Opportunities with such information requested by the commission, and permit access to pertinent books, records and accounts, concerning the employment practices and procedures of the contractor as relate to the provisions of this section and section 46a-56, as amended by this act. If the contract is a public works contract, the contractor agrees and warrants that he will make good faith efforts to employ minority business enterprises as subcontractors and suppliers of materials on such public works project. Prior to entering into the contract, the contractor shall provide the state or such political subdivision of the state with documentation in the form of a company or corporate policy adopted by resolution of the board of directors, shareholders, managers, members or other governing body of such contractor to support the nondiscrimination agreement and warranty under subdivision (1) of this subsection. For the purposes of this section, "contract" includes any extension or modification of the contract, and "contractor" includes any successors or assigns of the contractor.
- (b) For the purposes of this section, "minority business enterprise" means any small contractor or supplier of materials fifty-one per cent or more of the capital stock, if any, or assets of which is owned by a person or persons: (1) Who are active in the daily affairs of the enterprise, (2) who have the power to direct the management and policies of the enterprise and (3) who are members of a minority, as such term is defined in subsection (a) of section 32-9n; and "good faith" means that degree of diligence which a reasonable person would exercise in the performance of legal duties and obligations. "Good faith efforts" shall include, but not be limited to, those reasonable initial efforts necessary to comply with statutory or regulatory requirements and additional or substituted efforts when it is determined that such initial efforts will not be sufficient to comply with such requirements.

### **Sec. 4a-60a. Contracts of the state and political subdivisions, other than municipalities, to contain provisions re nondiscrimination on the basis of sexual orientation.**

- a) Every contract to which the state or any political subdivision of the state other than a municipality is a party shall contain the following provisions: (1) The contractor agrees and warrants that in the performance of the contract such contractor will not discriminate or permit discrimination against any person or group of persons on the grounds of sexual orientation, in any manner prohibited by the laws of the United States or of the state of Connecticut, and that employees are treated when employed without regard to their sexual orientation; (2) the contractor agrees to provide each labor union or representative of workers with which such contractor has a collective bargaining agreement or other contract or understanding and each vendor with which such contractor has a contract or understanding, a notice to be provided by the Commission on Human Rights and Opportunities advising the labor union or workers' representative of the contractor's commitments under this section, and to post copies of the notice in conspicuous places available to employees and applicants for employment; (3) the contractor

agrees to comply with each provision of this section and with each regulation or relevant order issued by said commission pursuant to section 46a-56, as amended by this act; (4) the contractor agrees to provide the Commission on Human Rights and Opportunities with such information requested by the commission, and permit access to pertinent books, records and accounts, concerning the employment practices and procedures of the contractor which relate to the provisions of this section and section 46a-56, as amended by this act. Prior to entering into the contract, the contractor shall provide the state or such political subdivision of the state with documentation in the form of a company or corporate policy adopted by resolution of the board of directors, shareholders, managers, members or other governing body of such contractor to support the nondiscrimination agreement and warranty under subdivision (1) of this subsection. For the purposes of this section, "contract" includes any extension or modification of the contract, and "contractor" includes any successors or assigns of the contractor.

- (b) The contractor shall include the provisions of subsection (a) of this section in every subcontract or purchase order entered into in order to fulfill any obligation of a contract with the state and such provisions shall be binding on a subcontractor, vendor or manufacturer unless exempted by regulations or orders of the commission. The contractor shall take such action with respect to any such subcontract or purchase order as the commission may direct as a means of enforcing such provisions including sanctions for noncompliance in accordance with section 46a-56; provided, if such contractor becomes involved in, or is threatened with, litigation with a subcontractor or vendor as a result of such direction by the commission, the contractor may request the state of Connecticut to enter into any such litigation or negotiation prior thereto to protect the interests of the state and the state may so enter.



**STATE OF CONNECTICUT**  
**GIFT AND CAMPAIGN CONTRIBUTION CERTIFICATION**  
**Bid #4-0015**

*Certification to accompany a State contract with a value of \$50,000 or more in a calendar or fiscal year, pursuant to C.G.S. §§ 4-250 and 4-252(c); Governor M. Jodi Rell's Executive Orders No. 1, Para. 8, and No. 7C, Para. 10; and C.G.S. §9-612(g)(2), as amended by Public Act 07-1*

**INSTRUCTIONS:**

Complete all sections of the form. Attach additional pages, if necessary, to provide full disclosure about any lawful campaign contributions made to campaigns of candidates for statewide public office or the General Assembly, as described herein. Sign and date the form, under oath, in the presence of a Commissioner of the Superior Court or Notary Public. Submit the completed form to the awarding State agency at the time of initial contract execution (and on each anniversary date of a multi-year contract, if applicable).

**CHECK ONE:**     Initial Certification                       Annual Update (Multi-year contracts only.)

**GIFT CERTIFICATION:**

As used in this certification, the following terms have the meaning set forth below:

- 1) "Contract" means that contract between the State of Connecticut (and/or one or more of its agencies or instrumentalities) and the Contractor, attached hereto, or as otherwise described by the awarding State agency below;
- 2) If this is an Initial Certification, "Execution Date" means the date the Contract is fully executed by, and becomes effective between, the parties; if this is an Annual Update, "Execution Date" means the date this certification is signed by the Contractor;
- 3) "Contractor" means the person, firm or corporation named as the contractor below;
- 4) "Applicable Public Official or State Employee" means any public official or state employee described in C.G.S. §4-252(c)(1)(i) or (ii);
- 5) "Gift" has the same meaning given that term in C.G.S. § 4-250(1);
- 6) "Planning Start Date" is the date the State agency began planning the project, services, procurement, lease or licensing arrangement covered by this Contract, as indicated by the awarding State agency below; and
- 7) "Principals or Key Personnel" means and refers to those principals and key personnel of the Contractor, and its or their agents, as described in C.G.S. §§ 4-250(5) and 4-252(c)(1)(B) and (C).

I, the undersigned, am the official authorized to execute the Contract on behalf of the Contractor. I hereby certify that, between the Planning Start Date and Execution Date, neither the Contractor nor any Principals or Key Personnel has made, will make (or has promised, or offered, to, or otherwise indicated that he, she or it will, make) any **Gifts** to any Applicable Public Official or State Employee.

I further certify that no Principals or Key Personnel know of any action by the Contractor to circumvent (or which would result in the circumvention of) the above certification regarding **Gifts** by providing for any other principals, key personnel, officials, or employees of the Contractor, or its or their agents, to make a **Gift** to any Applicable Public Official or State Employee. I further certify that the Contractor made the bid or proposal for the Contract without fraud or collusion with any person.

**CAMPAIGN CONTRIBUTION CERTIFICATION:**

I further certify that, on or after December 31, 2006, neither the Contractor nor any of its principals, as defined in C.G.S. § 9-612(g)(1), has made any **campaign contributions** to, or solicited any contributions on behalf of, any exploratory committee, candidate committee, political committee, or party committee established by, or supporting or authorized to support, any candidate for statewide public office, in violation of C.G.S. § 9-612(g)(2)(A). I further certify that **all lawful campaign contributions** that have been made on or after December 31, 2006 by the Contractor or any of its principals, as defined in C.G.S. § 9-612(g)(1), to, or solicited on behalf of, any exploratory committee, candidate committee, political committee, or party committee established by, or supporting or authorized to support any candidates for statewide public office or the General Assembly, are listed below:





STATE OF CONNECTICUT
CONSULTING AGREEMENT AFFIDAVIT
Bid 4-0015

Affidavit to accompany a State contract for the purchase of goods and services with a value of \$50,000 or more in a calendar or fiscal year, pursuant to Connecticut General Statutes §§ 4a-81(a) and 4a-81(b)

INSTRUCTIONS:

If the bidder or vendor has entered into a consulting agreement, as defined by Connecticut General Statutes § 4a-81(b)(1): Complete all sections of the form. If the bidder or vendor has entered into more than one such consulting agreement, use a separate form for each agreement. Sign and date the form in the presence of a Commissioner of the Superior Court or Notary Public. If the bidder or vendor has not entered into a consulting agreement, as defined by Connecticut General Statutes § 4a-81(b)(1): Complete only the shaded section of the form. Sign and date the form in the presence of a Commissioner of the Superior Court or Notary Public.

Submit completed form to the awarding State agency with bid or proposal. For a sole source award, submit completed form to the awarding State agency at the time of contract execution.

This affidavit must be amended if the contractor enters into any new consulting agreement(s) during the term of the State contract.

AFFIDAVIT: [Number of Affidavits Sworn and Subscribed On This Day: \_\_\_\_\_ ]

I, the undersigned, hereby swear that I am the chief official of the bidder or vendor awarded a contract, as described in Connecticut General Statutes § 4a-81(a), or that I am the individual awarded such a contract who is authorized to execute such contract. I further swear that I have not entered into any consulting agreement in connection with such contract, except for the agreement listed below:

Consultant's Name and Title Name of Firm (if applicable)

Start Date End Date Cost

Description of Services Provided:

Is the consultant a former State employee or former public official? [ ] YES [ ] NO

If YES: Name of Former State Agency Termination Date of Employment

Sworn as true to the best of my knowledge and belief, subject to the penalties of false statement.

Printed Name of Bidder or Vendor Signature of Chief Official or Individual Date
Printed Name (of above) Awarding State Agency

Sworn and subscribed before me on this \_\_\_\_\_ day of \_\_\_\_\_, 200\_\_.

Commissioner of the Superior Court
or Notary Public



STATE OF CONNECTICUT
AFFIRMATION OF RECEIPT OF STATE ETHICS LAWS SUMMARY
Bid 4-0015

Affirmation to accompany a large State construction or procurement contract, having a cost of more than \$500,000, pursuant to Connecticut General Statutes §§ 1-101mm and 1-101qq

INSTRUCTIONS:

Complete all sections of the form. Submit completed form to the awarding State agency or contractor, as directed below.

CHECK ONE:

- I am a person seeking a large State construction or procurement contract. I am submitting this affirmation to the awarding State agency with my bid or proposal. [Check this box if the contract will be awarded through a competitive process.]
I am a contractor who has been awarded a large State construction or procurement contract. I am submitting this affirmation to the awarding State agency at the time of contract execution. [Check this box if the contract was a sole source award.]
I am a subcontractor or consultant of a contractor who has been awarded a large State construction or procurement contract. I am submitting this affirmation to the contractor.

IMPORTANT NOTE:

Contractors shall submit the affirmations of their subcontractors and consultants to the awarding State agency. Failure to submit such affirmations in a timely manner shall be cause for termination of the large State construction or procurement contract.

AFFIRMATION:

I, the undersigned person, contractor, subcontractor, consultant, or the duly authorized representative thereof, affirm (1) receipt of the summary of State ethics laws\* developed by the Office of State Ethics pursuant to Connecticut General Statutes § 1-81b and (2) that key employees of such person, contractor, subcontractor, or consultant have read and understand the summary and agree to comply with its provisions.

\* The summary of State ethics laws is available on the State of Connecticut's Office of State Ethics website at http://www.ct.gov/ethics/lib/ethics/contractors\_guide\_final2.pdf

Signature

Date

Printed Name

Title

Firm or Corporation (if applicable)

Street Address

City

State

Zip

Awarding State Agency

**NOTICE TO EXECUTIVE BRANCH STATE CONTRACTORS AND PROSPECTIVE STATE CONTRACTORS OF CAMPAIGN CONTRIBUTION AND SOLICITATION BAN**

This notice is provided under the authority of Connecticut General Statutes 9-612(g)(2), as amended by P.A. 07-1, and is for the purpose of informing state contractors and prospective state contractors of the following law (italicized words are defined below):

**Campaign Contribution and Solicitation Ban**

No *state contractor, prospective state contractor, principal of a state contractor or principal of a prospective state contractor*, with regard to a *state contract* or *state contract solicitation* with or from a state agency in the executive branch or a quasi-public agency or a holder, or principal of a holder of a valid prequalification certificate, shall make a contribution to, or *solicit* contributions on behalf of (i) an exploratory committee or candidate committee established by a candidate for nomination or election to the office of Governor, Lieutenant Governor, Attorney General, State Comptroller, Secretary of the State or State Treasurer, (ii) a political committee authorized to make contributions or expenditures to or for the benefit of such candidates, or (iii) a party committee;

In addition, no holder or principal of a holder of a valid prequalification certificate, shall make a contribution to, or solicit contributions on behalf of (i) an exploratory committee or candidate committee established by a candidate for nomination or election to the office of State senator or State representative, (ii) a political committee authorized to make contributions or expenditures to or for the benefit of such candidates, or (iii) a party committee.

**Duty to Inform**

State contractors and prospective state contractors are required to inform their principals of the above prohibitions, as applicable, and the possible penalties and other consequences of any violation thereof.

**Penalties for Violations**

Contributions or solicitations of contributions made in violation of the above prohibitions may result in the following civil and criminal penalties:

Civil penalties--\$2000 or twice the amount of the prohibited contribution, whichever is greater, against a principal or a contractor. Any state contractor or prospective state contractor which fails to make reasonable efforts to comply with the provisions requiring notice to its principals of these prohibitions and the possible consequences of their violations may also be subject to civil penalties of \$2000 or twice the amount of the prohibited contributions made by their principals.

Criminal penalties—Any knowing and willful violation of the prohibition is a Class D felony, which may subject the violator to imprisonment of not more than 5 years, or \$5000 in fines, or both.

**Contract Consequences**

Contributions made or solicited in violation of the above prohibitions may result, in the case of a state contractor, in the contract being voided.

Contributions made or solicited in violation of the above prohibitions, in the case of a prospective state contractor, shall result in the contract described in the state contract solicitation not being awarded to the prospective state contractor, unless the State Elections Enforcement Commission determines that mitigating circumstances exist concerning such violation.

The State will not award any other state contract to anyone found in violation of the above prohibitions for a period of one year after the election for which such contribution is made or solicited, unless the State Elections Enforcement Commission determines that mitigating circumstances exist concerning such violation.

Additional information and the entire text of P.A 07-1 may be found on the website of the State Elections Enforcement Commission, [www.ct.gov/seec](http://www.ct.gov/seec). Click on the link to “State Contractor Contribution Ban.”



Definitions:

"State contractor" means a person, business entity or nonprofit organization that enters into a state contract. Such person, business entity or nonprofit organization shall be deemed to be a state contractor until December thirty-first of the year in which such contract terminates. "State contractor" does not include a municipality or any other political subdivision of the state, including any entities or associations duly created by the municipality or political subdivision exclusively amongst themselves to further any purpose authorized by statute or charter, or an employee in the executive or legislative branch of state government or a quasi-public agency, whether in the classified or unclassified service and full or part-time, and only in such person's capacity as a state or quasi-public agency employee.

"Prospective state contractor" means a person, business entity or nonprofit organization that (i) submits a response to a state contract solicitation by the state, a state agency or a quasi-public agency, or a proposal in response to a request for proposals by the state, a state agency or a quasi-public agency, until the contract has been entered into, or (ii) holds a valid prequalification certificate issued by the Commissioner of Administrative Services under section 4a-100. "Prospective state contractor" does not include a municipality or any other political subdivision of the state, including any entities or associations duly created by the municipality or political subdivision exclusively amongst themselves to further any purpose authorized by statute or charter, or an employee in the executive or legislative branch of state government or a quasi-public agency, whether in the classified or unclassified service and full or part-time, and only in such person's capacity as a state or quasi-public agency employee.

"Principal of a state contractor or prospective state contractor" means (i) any individual who is a member of the board of directors of, or has an ownership interest of five per cent or more in, a state contractor or prospective state contractor, which is a business entity, except for an individual who is a member of the board of directors of a nonprofit organization, (ii) an individual who is employed by a state contractor or prospective state contractor, which is a business entity, as president, treasurer or executive vice president, (iii) an individual who is the chief executive officer of a state contractor or prospective state contractor, which is not a business entity, or if a state contractor or prospective state contractor has no such officer, then the officer who duly possesses comparable powers and duties, (iv) an officer or an employee of any state contractor or prospective state contractor who has *managerial or discretionary responsibilities with respect to a state contract*, (v) the spouse or a *dependent child* who is eighteen years of age or older of an individual described in this subparagraph, or (vi) a political committee established or controlled by an individual described in this subparagraph or the business entity or nonprofit organization that is the state contractor or prospective state contractor.

"State contract" means an agreement or contract with the state or any state agency or any quasi-public agency, let through a procurement process or otherwise, having a value of fifty thousand dollars or more, or a combination or series of such agreements or contracts having a value of one hundred thousand dollars or more in a calendar year, for (i) the rendition of services, (ii) the furnishing of any goods, material, supplies, equipment or any items of any kind, (iii) the construction, alteration or repair of any public building or public work, (iv) the acquisition, sale or lease of any land or building, (v) a licensing arrangement, or (vi) a grant, loan or loan guarantee. "State contract" does not include any agreement or contract with the state, any state agency or any quasi-public agency that is exclusively federally funded, an education loan or a loan to an individual for other than commercial purposes.

"State contract solicitation" means a request by a state agency or quasi-public agency, in whatever form issued, including, but not limited to, an invitation to bid, request for proposals, request for information or request for quotes, inviting bids, quotes or other types of submittals, through a competitive procurement process or another process authorized by law waiving competitive procurement.

"Managerial or discretionary responsibilities with respect to a state contract" means having direct, extensive and substantive responsibilities with respect to the negotiation of the state contract and not peripheral, clerical or ministerial responsibilities.

"Dependent child" means a child residing in an individual's household who may legally be claimed as a dependent on the federal income tax of such individual.

"Solicit" means (A) requesting that a contribution be made, (B) participating in any fund-raising activities for a candidate committee, exploratory committee, political committee or party committee, including, but not limited to, forwarding tickets to potential contributors, receiving contributions for transmission to any such committee or bundling contributions, (C) serving as chairperson, treasurer or deputy treasurer of any such committee, or (D) establishing a political committee for the sole purpose of soliciting or receiving contributions for any committee. Solicit does not include: (i) making a contribution that is otherwise permitted by Chapter 155 of the Connecticut General Statutes; (ii) informing any person of a position taken by a candidate for public office or a public official, (iii) notifying the person of any activities of, or contact information for, any candidate for public office; or (iv) serving as a member in any party committee or as an officer of such committee that is not otherwise prohibited in this section.



**UNIVERSITY OF CONNECTICUT HEALTH CENTER  
NON-DISCRIMINATION CERTIFICATION  
Bid 4-0015**

*Certification to accompany all State contracts, regardless of type, term, cost, or value., pursuant to Connecticut General Statutes §4a-60(a)(1) and § 4a-60a(a)(1), as amended by Public Act 07-245 and Section 9(a)(1) and 10(a)(1) of Public Act 07-142.*

(By \_\_\_\_\_ (corporate or other business entity) regarding support of nondiscrimination against persons on account of their race, color, religious creed, age, marital or civil union status, national origin, ancestry, sex, mental retardation, physical disability or sexual orientation.)

I \_\_\_\_\_ (signer's name) \_\_\_\_\_ (signer's title)  
of \_\_\_\_\_ an entity lawfully organized and existing under the laws of  
(name of entity)

\_\_\_\_\_ do hereby certify that the following is a true and correct copy  
(name of state or commonwealth)  
of a resolution adopted on the \_\_\_ day of \_\_\_\_\_, 20\_\_ by the governing body of \_\_\_\_\_  
(name of entity)

in accordance with all of its documents of governance and management and the laws of  
\_\_\_\_\_ and further certify that such resolution has not been modified,  
(name of state or commonwealth)  
rescinded, or revoked, and is at present in full force and effect.

RESOLVED: That \_\_\_\_\_ hereby adopts as is policy  
(name of entity)  
to support the nondiscrimination agreements and warranties required under Connecticut  
General Statutes § 4a-60(a)(1) and § 4a-60a(a)(1), as amended in State of Connecticut  
Public Act 07-245 and sections 9(a)(1) and 10(a)(1) of Public Act 07-142.

WHEREOF, I, the undersigned have executed this certificate this \_\_\_\_ day of  
\_\_\_\_\_ 20\_\_

Print  
Name: \_\_\_\_\_

Title: \_\_\_\_\_

\_\_\_\_\_  
Signature Date



**UNIVERSITY OF CONNECTICUT HEALTH CENTER  
NON-DISCRIMINATION CERTIFICATION  
Bid 4-0015**

*Certification to accompany all State contracts, regardless of type, term, cost, or value., pursuant to Connecticut General Statutes §4a-60(a)(1) and § 4a-60a(a)(1), as amended by Public Act 07-245 and Section 9(a)(1) and 10(a)(1) of Public Act 07-142.*

*(By \_\_\_\_\_ (individual contractor) regarding support of nondiscrimination against persons on account of their race, color, religious creed, age, marital or civil union status, national origin, ancestry, sex, mental retardation, physical disability or sexual orientation.)*

I \_\_\_\_\_ of \_\_\_\_\_ am entering  
(signer's name) (business address)  
into a contract (or an extension or other modification of an existing contract) with the State of Connecticut (the "State") in my individual capacity for

\_\_\_\_\_  
(If available, insert "Contract No." otherwise generally describe goods or services to be provided).

I hereby certify that I support the nondiscrimination agreements and warranties required under Connecticut General Statutes Sections 4a-60(a)(1) and 4a-60a(a)(1), as amended in State of Public Act 07-245 and Sections 9(a)(1) and 10(a)(1) of Public Act 07-142.

WHEREOF, I, the undersigned have executed this certificate this \_\_\_\_ day of \_\_\_\_\_ 20\_\_

Print Name: \_\_\_\_\_

\_\_\_\_\_  
Signature

\_\_\_\_\_  
Date