



State of Connecticut  
 Eastern Connecticut State University  
 83 Windham Street  
 Willimantic, CT 06226

Bid number	Mandatory Pre-Bid	Bid Opening Date	Bid Opening Time	Date Issued
ECSU 2020-8	Date: 4/29/20 Time: 10 AM Place: Athletic Complex	5/13/20	2:00 PM	4/22/20

**Agency Contact:**

Cindy Hodis  
 Acquisitions Manager  
 860-465-5148  
 Email: [hodisc@easternct.edu](mailto:hodisc@easternct.edu)

**AFFIRMATION OF BIDDER: The undersigned bidder affirms and declares:**

1. That this proposal is executed and signed by said bidder with full knowledge and acceptance of the provisions of Form ECSU-02 (Standard Bid and Contract Terms and Conditions) of current issue and in effect on the date of bid issue.
2. Your written signature below indicates agreement of terms and conditions on page 2 and 3 of this document.

BIDDER INFORMATION				
Complete Company Name (Trade Name, DBA)			Social Security or Federal Employer ID Number	
Company Address:	Street	City	State	Zip Code
Contact Name (typed or printed)	Email address	Telephone Number	Fax Number	
Signature of Person Authorized to Sign Bids on Behalf of the above named company				Date Executed
Is your business currently a Department of Administrative Services Certified Small Business Enterprise:				
<input type="checkbox"/> Yes (Attach Certificate to Bid) <input type="checkbox"/> No				
Is your business a:				
<input type="checkbox"/> Sole Proprietorship <input type="checkbox"/> Partnership <input type="checkbox"/> Corporation (Type & State of Incorporation) _____ <input type="checkbox"/> LLC – sole owner <input type="checkbox"/> LLC – Partnership <input type="checkbox"/> LLC - Corporation				
If you are a State Employee, indicate your position/ agency/ and address:				
Remittance Address (If different from above):				
<b>Total Bid Price: \$</b>				
<b>RETURN BID TO ECSU IN A SEALED ENVELOPE CLEARLY MARKED IN THE LOWER LEFT CORNER WITH THE BID NUMBER, DUE DATE AND TIME.</b> <b>(NOTE: FACSIMILE BIDS ARE <u>NOT</u> ACCEPTABLE)</b> ECSU PURCHASING DEPARTMENT EASTERN ROAD GELSI & YOUNG HALL, ROOM 344 WILLIMANTIC, CT 06226				

**THIS FORM AND REQUIRED PROPOSAL SCHEDULE FORMS MUST BE COMPLETED AND RETURNED WITH BID PROPOSAL**

**EXECUTIVE ORDERS:** This contract is subject to the provisions of Executive Order No Three of Governor Thomas J. Meskill, promulgated June 16, 1971, and, as such, this contract may be cancelled, terminated or suspended by the State Labor Commissioner for violation of noncompliance with said Executive Order No. Three, or any State or federal law concerning nondiscrimination, withstanding that the Labor Commissioner is not a party to this contract. The parties of this contract, as part of the consideration hereof, agree that said Executive Order No. Three is incorporated herein by reference and made a part hereof. The parties agree to abide by said Executive Order and agree that the State Labor Commissioner shall have continuing jurisdiction in respect to contract performance in regard to nondiscrimination, until the contract is completed or terminated prior to completion. The contractor, agrees as part of consideration hereof, that this contract is subject to the Guidelines and Rules issued by the State Labor Commissioner to Implement Executive Order No. Three, and that he will not discriminate in his employment practices or policies, will file all reports as required, and will fully cooperate with the State of Connecticut and the Labor Commissioner. This contract is also subject to the provisions of Executive Order No. Seventeen of Governor Thomas J. Meskill promulgated February 15, 1973, and, as such, this contract may be cancelled, terminated or suspended by the contracting agency or the State Labor Commissioner for violation of or noncompliance with said Executive Order No. Seventeen, notwithstanding that the Labor Commissioner may not be a party to this contract. The parties of this contract, as a part of the consideration hereof, agree that Executive Order No. Seventeen is incorporated herein by reference and made a part hereof. The parties agree to abide by said Executive Order and agree that the contracting agency and the State Labor Commissioner shall have joint and several continuing jurisdiction in respect to contract performance in regard to listing all employment openings with the Connecticut State Employment Service.

#### NON-DISCRIMINATION

References in this section to "contract" shall mean this Contract and references to "contractor" shall mean the Contractor.

- (a) The following subsections are set forth here as required by section 4a-60 of the Connecticut General Statutes:
- (1) The contractor agrees and warrants that in the performance of the contract such contractor will not discriminate or permit discrimination against any person or group of persons on the grounds of race, color, religious creed, age, marital status, national origin, ancestry, sex, mental retardation, mental disability or physical disability, including, but not limited to, blindness, unless it is shown by such contractor that such disability prevents performance of the work involved, in any manner prohibited by the laws of the United States or of the state of Connecticut. The contractor further agrees to take affirmative action to insure that applicants with job-related qualifications are employed and that employees are treated when employed without regard to their race, color, religious creed, age, marital status, national origin, ancestry, sex, mental retardation, mental disability or physical disability, including, but not limited to, blindness, unless it is shown by such contractor that such disability prevents performance of the work involved;
  - (2) the contractor agrees, in all solicitations or advertisements for employees placed by or on behalf of the contractor, to state that it is an "affirmative action-equal opportunity employer" in accordance with regulations adopted by the commission;
  - (3) the contractor agrees to provide each labor union or representative of workers with which such contractor has a collective bargaining agreement or other contract or understanding and each vendor with which such contractor has a contract or understanding, a notice to be provided by the commission advising the labor union or workers' representative of the contractor's commitments under this section, and to post copies of the notice in conspicuous places available to employees and applicants for employment;
  - (4) the contractor agrees to comply with each provision of this section and sections 46a-68e and 46a-68f and with each regulation or relevant order issued by said commission pursuant to sections 46a-56, 46a-68e and 46a-68f;
  - (5) the contractor agrees to provide the Commission on Human Rights and Opportunities with such information requested by the commission, and permit access to pertinent books, records and accounts, concerning the employment practices and procedures of the contractor as relate to the provisions of this section and section 46a-56.
- (b) If the contract is a public works contract, the contractor agrees and warrants that he will make good faith efforts to employ minority business enterprises as subcontractors and suppliers of materials on such public works project.
- (c) "Minority business enterprise" means any small contractor or supplier of materials fifty-one per cent or more of the capital stock, if any, or assets of which is owned by a person or persons: (1) Who are active in the daily affairs of the enterprise, (2) who have the power to direct the management and policies of the enterprise and (3) who are members of a minority, as such term is defined in subsection (a) of section 32-9n; and "good faith" means that degree of diligence which a reasonable person would exercise in the performance of legal duties and obligations. "Good faith efforts" shall include, but not be limited to, those reasonable initial efforts necessary to

comply with statutory or regulatory requirements and additional or substituted efforts when it is determined that such initial efforts will not be sufficient to comply with such requirements.

- (d) Determination of the contractor's good faith efforts shall include but shall not be limited to the following factors: The contractor's employment and subcontracting policies, patterns and practices; affirmative advertising, recruitment and training; technical assistance activities and such other reasonable activities or efforts as the commission may prescribe that are designed to ensure the participation of minority business enterprises in public works projects.
- (e) The contractor shall develop and maintain adequate documentation, in a manner prescribed by the commission, of its good faith efforts.
- (f) The contractor shall include the provisions of section A above in every subcontract or purchase order entered into in order to fulfill any obligation of a contract with the state and such provisions shall be binding on a subcontractor, vendor or manufacturer unless exempted by regulations or orders of the commission. The contractor shall take such action with respect to any such subcontract or purchase order as the commission may direct as a means of enforcing such provisions including sanctions for noncompliance in accordance with section 46a-56; provided, if such contractor becomes involved in, or is threatened with, litigation with a subcontractor or vendor as a result of such direction by the commission, the contractor may request the state of Connecticut to enter into any such litigation or negotiation prior thereto to protect the interests of the state and the state may so enter.
- (g) The following subsections are set forth here as required by section 4a-60a of the Connecticut General Statutes:
  - (1) The contractor agrees and warrants that in the performance of the contract such contractor will not discriminate or permit discrimination against any person or group of persons on the grounds of sexual orientation, in any manner prohibited by the laws of the United States or of the state of Connecticut, and that employees are treated when employed without regard to their sexual orientation;
  - (2) the contractor agrees to provide each labor union or representative of workers with which such contractor has a collective bargaining agreement or other contract or understanding and each vendor with which such contractor has a contract or understanding, a notice to be provided by the Commission on Human Rights and Opportunities advising the labor union or workers' representative of the contractor's commitments under this section, and to post copies of the notice in conspicuous places available to employees and applicants for employment;
  - (3) the contractor agrees to comply with each provision of this section and with each regulation or relevant order issued by said commission pursuant to section 46a-56; and
  - (4) the contractor agrees to provide the Commission on Human Rights and Opportunities with such information requested by the commission, and permit access to pertinent books, records and accounts, concerning the employment practices and procedures of the contractor which relate to the provisions of this section and section 46a-56.
- (h) The contractor shall include the provisions of section (g) above in every subcontract or purchase order entered into in order to fulfill any obligation of a contract with the state and such provisions shall be binding on a subcontractor, vendor or manufacturer unless exempted by regulations or orders of the commission. The contractor shall take such action with respect to any such subcontract or purchase order as the commission may direct as a means of enforcing such provisions including sanctions for noncompliance in accordance with section 46a-56; provided, if such contractor becomes involved in, or is threatened with, litigation with a subcontractor or vendor as a result of such direction by the commission, the contractor may request the state of Connecticut to enter into any such litigation or negotiation prior thereto to protect the interests of the state and the state may so enter.

For the purposes of this entire Non-Discrimination section, "contract" includes any extension or modification of the contract, "contractor" includes any successors or assigns of the contractor, "marital status" means being single, married as recognized by the state of Connecticut, widowed, separated or divorced, and "mental disability" means one or more mental disorders, as defined in the most recent edition of the American Psychiatric Association's "Diagnostic and Statistical Manual of Mental Disorders", or a record of or regarding a person as having one or more such disorders. For the purposes of this section, "contract" does not include a contract where each contractor is (1) a political subdivision of the state, including, but not limited to, a municipality, (2) a quasi-public agency, as defined in Conn. Gen. Stat. Section 1-120, (3) any other state, including but not limited to any federally recognized Indian tribal governments, as defined in Conn. Gen. Stat. Section 1-267, (4) the federal government, (5) a foreign government, or (6) an agency of a subdivision, agency, state or government described in the immediately preceding enumerated items (1), (2), (3), (4) or (5).

### **Insurance**

The contractor agrees that while performing services specified in this agreement that he shall carry sufficient insurance (liability and/or other) as applicable according to the nature of the service to be performed so as to "save

harmless” the State of Connecticut from any insurable cause whatsoever. If requested, certificates of such insurance shall be filed with the contracting State Agency prior to the performance of services.

**STATE LIABILITY**

The State of Connecticut shall assume no liability for payment for services under the terms of this agreement until the contractor is notified that this agreement has been accepted by the using agency and, if applicable, approved by the Office of Policy and Management (OPM), the Department of Administrative Services and by the Attorney General of the State of Connecticut.

EASTERN CONNECTICUT STATE UNIVERSITY  
INVITATION TO BID PROJECT # ECSU 2020-8  
Baseball, Softball & Rugby Field Renovation

**SUBMISSION CHECK LIST**

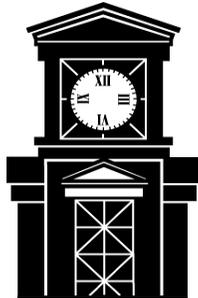
- ( ) Bidder Information Cover Sheet
- ( ) Proposal/Project Data Sheet
- ( ) Bidder's Qualification Statement
- ( ) Standard Bid Bond or Certified Check in the amount of 10% of the bid
- ( ) Contract Compliance Monitoring Report (3 pages)
- ( ) Gift Affidavit (Form 1)
- ( ) Consulting Affidavit (Form 5)
- ( ) Nondiscrimination Certificate
- ( ) W9, Vendor Form and Small Business Certification (if applicable)
- ( ) Sub-Contractor Worksheet

# PROJECT MANUAL

## BASEBALL, SOFTBALL, & RUGBY FIELD RENOVATION

EASTERN CONNECTICUT STATE UNIVERSITY  
WILLIMANTIC, CONNECTICUT 06226-2295

**PROJECT NUMBER: ECSU 2020-8**



Prepared by:

Facilities Management and Planning  
Eastern Connecticut State University  
Willimantic, Connecticut 06226-2295

April 2020



**PROJECT MANUAL TABLE OF CONTENTS**

<b>TITLE</b>		
<b>DIVISION 0</b>	<b>BIDDING REQUIREMENTS, CONTRACT FORMS, AND CONDITIONS OF THE CONTRACT</b>	<b>Page Count</b>
	Proposal Form	8
	Objective Criteria for Evaluating Qualifications of Bidders	2
	Bidders Qualification Statement	5
	Notice To Bidders	10
	Wage rates	27
	Certificate of Insurance	3
	Contract	1
	Commission on Human Rights and Opportunities	1
	Compliance Regulations/Notification to Bidders	
	Amendment 1A	1
	Executive Order #14	1
	Form 1 – Gift & Campaign Contribution Certifications Affidavit	2
	Campaign Contribution Restriction Provision	5
	Form 3 – Certification by Agency Official or Employee	1
	Authorized to Execute Contract	
	SEEC Form 11 Campaign Contributions	2
	Form 5 – Consulting Agreement Affidavit	1
	Nondiscrimination Provision for Contracts	3
	OPM Non-Discrimination Certification	2
	OAG Non Discrimination Forms	5
	W9 Vendor Profile	5
	Inspection of Proposals and Confidential Information	1
	CSU Standard Terms & Conditions	5
	General Conditions of the Contract for Construction	44

**TECHNICAL SPECIFICATIONS**

<b>TITLE</b>		
<b>DIVISION 1</b>	<b>GENERAL REQUIREMENTS</b>	<b>Page Number</b>
<b>Section</b>		
<b>01000</b>	<b>Work Covered By Contract Documents</b>	<b>1</b>
<b>01001</b>	<b>Agency</b>	<b>1</b>
<b>01002</b>	<b>Architect and Engineer</b>	<b>1</b>
<b>01003</b>	<b>Construction Administrator</b>	<b>1-2</b>
<b>01010</b>	<b>Summary of Work</b>	<b>2 -3</b>
<b>01011</b>	<b>Examination of Site</b>	<b>3</b>
<b>01012</b>	<b>Project Documents</b>	<b>3</b>
<b>01013</b>	<b>Documents Furnished</b>	<b>3-4</b>
<b>01014</b>	<b>Contractor’s Use of Premises</b>	<b>4</b>
<b>01015</b>	<b>Occupancy Requirements</b>	<b>4-5</b>
<b>01019</b>	<b>Contract Considerations</b>	<b>5-9</b>
<b>01027</b>	<b>Application for Payments</b>	<b>9-12</b>
<b>01030</b>	<b>Supplemental Bids</b>	<b>12</b>
<b>01035</b>	<b>Modification Procedures</b>	<b>12-15</b>
<b>01040</b>	<b>Coordination</b>	<b>15-16</b>
<b>01045</b>	<b>Cutting and Patching</b>	<b>16 -17</b>
<b>01050</b>	<b>Field Engineering</b>	<b>17-18</b>

01095	Reference Standards & Definitions	18
01120	Renovation/Demolition Project Procedures	18-20
01121	Salvageable Materials	20
01200	Project Meetings	20-22
01300	Submittals	22-28
01310	Construction Schedules	28-29
01380	Construction Photographs	29-30
01400	Quality Control	30-32
01505	Temporary Electricity and Lighting	32
01520	Temporary Water	33
01525	Temporary Sanitary Facilities	33
01530	Fire Protection	33
01535	Construction Equipment	33
01540	Barriers and Enclosures	33
01545	Protection	34
01550	Security	34
01555	Traffic Ways	34
01560	Temporary Controls	34-35
01565	Storm Water Control	35
01570	Cleaning	35
01575	Project Signs	35
01580	Field Offices and Sheds	35
01585	Identification Badges	35
01600	Materials & Equipment Controls	36
01631	Equals and Substitutions	36-38
01650	Starting of Systems	38-39
01700	Contract Closeout	39-43
01730	Operation & Maintenance Data	43-44
01740	Warranties & Bonds	44-46

DIVISION 2		SITE WORK	Page Count
Section			
02200	General Earthwork		24
02230	Site Preparation		4
02810	Irrigation		10
02910	Athletic Playing Fields		15
02920	Topsoil		5

LIST OF DRAWINGS	
Drawing Number	Sheet Title
-	Cover Sheet
SP-1	Site Plan
GR-1	Grading Plan
DN-1	Detail Sheet

END OF TABLE OF CONTENTS

4/15/20

**PROPOSAL FORM**  
EASTERN CONNECTICUT STATE UNIVERSITY  
FOR PROJECTS ESTIMATED NOT TO EXCEED \$2,000,000.00

DATE \_\_\_\_\_

PROPOSAL OF \_\_\_\_\_  
BIDDER'S NAME

\_\_\_\_\_  
BIDDER'S ADDRESS

To: Eastern Connecticut State University  
83 Windham Street  
Willimantic, Connecticut 06226

Dear Sir:

1. In accordance with **Section 4b-91** of the Connecticut General Statutes and pursuant to, and in compliance with your Invitation to Bid, the Notice to Bidders, the form of contract including the conditions thereto, the form of required bond, I (we) propose to furnish the labor and/or materials, installed as required for the project named and numbered on the PROJECT DATA SHEET of this Proposal, to the extent of the Proposal submitted herein, furnishing all necessary equipment, machinery, tools, labor and other means of construction, and all materials specified in the manner and at the time prescribed strictly in accordance with the provisions of the contract, including specifications and/or drawings, together with all addenda issued by your authority and received prior to the scheduled closing time for the receipt of the bids, and in conformity with requirements of the Awarding Authority and any laws or departmental regulations of the State of Connecticut or of the United States which may affect the same, for and in consideration of the price(s) stated on the said PROJECT DATA SHEET, hereof.
2. The Lump Sum Base Bid by me (us) on the PROJECT DATA SHEET includes all work indicated on the drawings and/or described in the specifications, except:
  - A. Work covered by Supplemental Bids as may be listed on the PROJECT DATA SHEET.
3. This proposal is submitted subject to and in compliance with the foregoing and following conditions and/or information:
  - A. AWARD:  
  
**The award shall be made on the lowest Sum of base bid amount including any accepted supplemental bid(s). The supplemental bids must be accepted in sequential order as they are listed herein.** The Owner/Agency reserves the right to reject any or all bids, and to accept a bid in greater compliance with the materials, labor, and methods defined in this specification.

In the event of any discrepancy between the amount written in words and the amount written in numerical figures, the amount written in words shall be controlling.

The contractor is required to hold his bid price for sixty (60) days. In the event that the contract award is delayed beyond the (60) days, the Agency must obtain written confirmation from the contractor extending the bid.

**B. COMMENCEMENT AND COMPLETION OF WORK: (ARTICLE 6, GENERAL CONDITIONS)**

Commencement of work: The Contractor shall commence work within **ten (10)** working days after receiving notice to begin work by the Agency.

Construction Start: On or before **June 3, 2020**.

Substantial Completion: Shall be completed by **August 7, 2020**

Construction Duration: Construction Duration shall be **90** calendar days.

**C. LIQUIDATED DAMAGES: (ARTICLE 12, GENERAL CONDITIONS)**

Amount per calendar day: **N/A**

The parties agree that in the event of the contractor's failure to adhere to the schedule of the starting/completion dates, the harm to the university would be very difficult or impracticable to accurately estimate and that the amount fixed as liquidated damages is not a penalty, but a reasonable forecast of just compensation for said harm.

**D. CONTRACTORS INSURANCE REQUIRED: (ARTICLE 47, GENERAL CONDITIONS)**

1) The limits of liability for the Insurance required for this project shall be those listed in Article 47 of the General Conditions.

2) **BUILDERS RISK INSURANCE: The General Contractor shall maintain Builder's Risk insurance providing coverage for the entire work at the project site and shall also cover portions of the Work in transit. Coverage shall be written on an All-Risk, Replacement Cost, and completed Value Form basis in an amount at least equal to the projected completed value of the Work and the policy shall state that it is for the benefit of and payable to the State of Connecticut work, as their interests may appear.**

**E. STATEMENT OF BIDDER'S QUALIFICATIONS:** Essential information in regard to contractor's qualifications is submitted and is made part of this proposal.

**F. NONDISCRIMINATION AND LABOR RECRUITMENT:** I (we) agree that the contract awarded for this project shall be subject to Executive Orders No. Three and Seventeen, promulgated June 16, 1971, and February 15, 1973, respectively and to the Guidelines and Rules of the State Labor Commissioner implementing Executive Order No. Three and further agree to submit reports of Compliance

Staffing on Labor Department Form E.O. 3-1, when and as requested.

- G. NONVIOLENCE: I (we) agree that the contract awarded for this project shall be subject to Executive Order No. Sixteen, promulgated August 4, 1999.
- H. FEDERAL AND STATE WAGE DETERMINATIONS: The U.S. Secretary of Labor's latest decision and the State of Connecticut Wage Schedule are all incorporated in the documents as applicable. The higher rate (Federal or State) for any given occupation shall prevail. At the time of bidding, the bidder agrees to accept the current prevailing wage scale as provided by the Connecticut Department of Labor as applicable.
- I. CERTIFICATION OF BIDDER REGARDING EQUAL EMPLOYMENT OPPORTUNITY AND NONSEGREGATED FACILITIES: The General Contractor and subcontractors are hereby advised that, upon acceptance of their bids, they are obligated to fill out, within seven (7) calendar days, the certification required pursuant to Executive Order No. 11246 and agree to certify to the compliance of non-segregated facilities.

4. For bids in the amount of \$50,000.00 or greater, the following must accompany this proposal:

- A. A CERTIFIED CHECK or a CASHIER'S CHECK drawn to the order of the EASTERN CONNECTICUT STATE UNIVERSITY in the amount of 10% of the bid or in the amount of:

\_\_\_\_\_ DOLLARS (\$) )

and drawn on the \_\_\_\_\_  
(STATE BANK & TRUST) (NATIONAL BANKING ASSOC.)

located at \_\_\_\_\_  
(CITY & STATE)

which it is understood shall be cashed and the proceeds thereof used so far as may be necessary to reimburse EASTERN CONNECTICUT STATE UNIVERSITY for losses and damages arising by virtue of my (our) failure to file the required Bonds and execute the required contract in the event that this proposal is accepted by the Awarding Authority.

OR

- B. A BID BOND having as surety thereto a Surety Company or Companies authorized to transact business in the State of Connecticut and made out in the penal sum of 10% of the bid, or in the amount of:

\_\_\_\_\_ DOLLARS (\$) )

5. I (we), the undersigned, hereby declare that I am (we are) the only person(s) interested in the proposal and that it is made without any connection with any other person making any bid for the same work. No person acting for, or employed by, the State of Connecticut is directly or indirectly interested in this proposal, or in any contract which may be made under it, or in expected profits to arise therefrom. This proposal is made

without directly or indirectly influencing or attempting to influence any other person or corporation to bid or refrain from bidding or to influence the amount of the bid of any other person or corporation. This proposal is made in good faith without collusion or connection with any other person bidding for the same work and this proposal is made with distinct reference and relation to the plans and specifications prepared for this contract. I (we) further declare that in regard to the conditions affecting the work to be done and the labor and materials needed, this proposal is based solely on my (our) own investigations and research and not in reliance upon any representations of any employee, officer, or agent of the State.

6. The General Contractor on this project will be required to perform not less than 30% of the work with his own forces.
- A. The undersigned proposes to furnish all labor and materials required for \_\_\_\_\_ in \_\_\_\_\_, in accordance with the accompanying plans and specifications prepared by \_\_\_\_\_ for the contract price specified below subject to additions and deductions according to the terms of the specifications.
- B. This bid includes addenda numbered: \_\_\_\_\_
- C. The proposed Lump Sum Base Bid price is: \_\_\_\_\_ DOLLARS (\$) )

**SUPPLEMENTAL BID – Add Alternate #1**

To provide all labor, material and equipment in accordance with Specifications, Div. 1, Section 01030.

ADD \_\_\_\_\_ Dollars \$ \_\_\_\_\_  
(Written)

**SUPPLEMENTAL BID – Add Alternate #2**

To provide all labor, material and equipment in accordance with Specifications, Div. 1, Section 01030.

ADD \_\_\_\_\_ Dollars \$ \_\_\_\_\_  
(Written)

- D. The undersigned understands that, because of the approvals required by the State of Connecticut, particularly the funding process, the Agency's identification of the low bidder does not constitute acceptance of the offer and no contract exists until all approvals for the proposal are received and a purchase order is let indicating acceptance of this bid.
- E. The undersigned certifies that at least fifty-one percent of the ownership of the bidding company is held by a person or persons who are active in the daily affairs of the business and have the power to direct the management and policies of the business.

- F. The undersigned understands that a contractor awarded a contract or portion of contract under the SMALL BUSINESS SET-ASIDE PROGRAM shall not subcontract with any business with which said contractor has interlocking ownership, management or employees.

This project is subject to the State SET ASIDE goals and **NEW STATUTORY CHANGES TO 4a-60g effective 10/1/13** as it relates to new self- performance and subcontracting requirements.

- G. The undersigned further understands that documentation may be required or an audit for determination of eligibility may be performed to verify eligibility for awards or compliance with the SET-ASIDE PROGRAM.

The undersigned further understands that 100% of this contract is limited to currently registered Connecticut Registered Small Business Set-Aside contractors participation

The undersigned further understands that this contract requires 6.25% Connecticut Registered Small Business Set-Aside subcontractor participation which must be Woman or Minority Owned (WBE/MBE). Participating contractor list may be obtained from the Department of Economic Development (860) 258-4254.

P.A. 13-404 increases the percentages of work required to be self-performed by any prime SBE/MBE Company that is awarded a contract under the set-aside statutes. Previously a company awarded a set- aside contract was required to self perform 15% of such contract; it will now be required to self-perform at least 30%. Further SBE and MBE's that subcontract some of the work under their set-aside contracts will be required to sub-contract at least 50% of the remaining work

- H. The undersigned further agrees and warrants that he has made good faith efforts to employ minority business enterprises as subcontractors and suppliers of materials under such contract and will provide the Commission on Human Rights and Opportunities with such information as is requested by the Commission concerning his employment practices and procedures as they relate to the provisions of the general statutes governing contract requirements (see Public Act 87-577).

- I. (a) For the purposes of this section, "minority business enterprise" means any small contractor or supplier of materials, of which fifty-one per cent or more of the capital stock, if any, or assets is owned by a person or persons: (1) Who are active in the daily affairs of the enterprise, (2) Who have the power to direct the management and policies of the enterprise and (3) Who are members of a minority, as such term is defined in subsection (a) of Conn. Gen. Stat. Sec. 32-9n; and "good faith" means that degree of diligence which a reasonable person would exercise in the performance of legal duties and obligations. "Good faith efforts" shall include, but not be limited to, those reasonable initial efforts necessary to comply with statutory or regulatory requirements and additional or substituted efforts when it is determined that such initial efforts will not be sufficient to comply with such requirements.

For purposes of this Section, "Commission" means the Commission on Human Rights and Opportunities.

b) (1) The contractor agrees and warrants that in the performance of the contract such contractor will not discriminate or permit discrimination against any person or group of persons on the grounds of race, color, religious creed, age, marital status, national origin, ancestry, sex, mental retardation or physical disability, including, but not limited to, blindness, unless it is shown by such contractor that such disability prevents performance of the work involved, in any manner prohibited by the laws of the United States or of the State of Connecticut. If the contract is for a public works project, the contractor agrees and warrants that he will make good faith efforts to employ minority business enterprises as subcontractors and suppliers of materials on such project. The contractor further agrees to take affirmative action to insure that applicants with job related qualifications are employed and that employees are treated when employed without regard to their race, color, religious creed, age, marital status, national origin, ancestry, sex, mental retardation, or physical disability, including, but not limited to, blindness, unless it is shown by such contractor that such disability prevents performance of the work involved; (2) the contractor agrees, in all solicitations or advertisements for employees placed by or on behalf of the contractor, to state that it is an "affirmative action-equal opportunity employer" in accordance with regulations adopted by the commission; (3) the contractor agrees to provide each labor union or representative of workers with which such contractor has a collective bargaining agreement or other contract or understanding and each vendor with which such contractor has a contract or understanding, a notice to be provided by the commission, advising the labor union or worker's representative of the contractor's commitments under this section and to post copies of the notice in conspicuous places available to employees and applicants for employment; (4) the contractor agrees to comply with each provision of this Section and Conn. Gen. Stat. Sec. 4a-62, 4b-95/96, 32-9e, 46a-56 and 46a-68b to 46a-68k, inclusive, and with each regulation or relevant order issued by said commission pursuant to said sections; (5) the contractor agrees to provide the Commission on Human Rights and Opportunities with such information requested by the commission, and permit access to pertinent books, records and accounts, concerning the employment practices and procedures of the contractor as related to the provisions of this Section and Section 46a-56.

(c) Determination of the contractor's good faith efforts shall include, but shall not be limited to, the following factors: The contractor's employment and subcontracting policies, patterns and practices; affirmative advertising, recruitment and training; technical assistance activities and such other reasonable activities or efforts as the commission may prescribe that are minority business enterprises in public works projects.

(d) The contractor shall develop and maintain adequate documentation, in a manner prescribed by the commission, of its good faith efforts.

(e) The contractor shall include the provisions of subsection (b) of this section in every subcontract or purchase order entered into in order to fulfill any obligation of a contract with the state and such provisions shall be binding on a subcontractor, vendor, or manufacturer unless exempted by regulations or orders

of the Commission. The contractor shall take such action with respect to any such subcontract or purchase order as the Commission may direct as a means of enforcing such provisions including sanctions for noncompliance in accordance with this Section and Conn. Gen. Stat. Sec. 4a-62, 4b-95/96, 32-9e, 46a-56 and 46a-68b to 46a-68k, inclusive; provided if such contractor becomes involved in, or is threatened with, litigation with a subcontractor or vendor as a result of such direction by the Commission, the contractor may request the State of Connecticut to enter into any such litigation or negotiation prior thereto to protect the interests of the state and the state may so enter. Please note that substitution of a subcontractor for one named is not permitted except for "**GOOD CAUSE**" as defined in Connecticut General Statutes 4b-95(c). Subcontracts must be executed in the format proscribed in Sec. 4b-96, Connecticut General Statutes.

(f) The contractor agrees to comply with the regulations referred to in this section as they exist on the date of this contract and as they may be adopted or amended from time to time during the term of this contract and any amendments thereto.

(g) After April 1, 1989, each contractor with fifty or more employees awarded a public works contract in excess of fifty thousand dollars, shall develop and file an affirmative action plan with the Commission on Human Rights subject to the conditions under P.A. 88-351. In addition, the successful bidder on contracts of \$500,000 or more must submit, for approval, an Affirmative Action Plan to the Commission of Human Rights and Opportunities. Upon notification from Eastern Connecticut State University, the successful bidder has 10 calendar days to submit their plan to Eastern Connecticut State University for preliminary review.

The undersigned understands that the award of this category of contract is contingent upon the Commission on Human Rights and Opportunities approving the apparent lowest qualified bidder's Affirmative Action Plan.

PROJECT DATA SHEET

NOTE: All proposals must be live signed by a duly authorized representative of the firm.  
NO FACSIMILE SIGNATURES PERMITTED.

Signed on this \_\_\_\_\_ day of \_\_\_\_\_ 2020

Project Number \_\_\_\_\_

(TO BE FILLED IN AND SIGNED BY THE BIDDER)

Firm Name \_\_\_\_\_

Address \_\_\_\_\_

City, State \_\_\_\_\_

Telephone \_\_\_\_\_

Duly Authorized \_\_\_\_\_

SIGNATURE

TYPE NAME AND TITLE \_\_\_\_\_

**FOR "SMALL BUSINESS SET-ASIDE CONTRACTORS" ONLY**

The undersigned certifies that he is certified as a Small Business Set-Aside Contractor and has included a copy of that certification with this bid.

Signed: \_\_\_\_\_ Date: \_\_\_\_\_

Dates of Certification: \_\_\_\_\_

Type of Certification (circle one):    Woman            Minority            Small

OBJECTIVE CRITERIA ESTABLISHED FOR  
EVALUATING QUALIFICATIONS OF GENERAL BIDDERS

The following items are established pursuant to Sections 4b-92 & 4b-94, 31-53aa, and 31-57b of the Connecticut General Statutes, as amended, and represent the criteria used for bid award.

THE BIDDER MUST:

1. Low bidders must demonstrate that they customarily employ supervisory personnel with expertise in the work for the bid specifications. Experience in the trade(s) for the project will be a factor.
2. Low bidders must demonstrate satisfactory past performance of work of a similar size, scope, and dollar value to that of the subject project on a continuous basis for the past three (3) years.
3. Low bidders must own or will rent/lease equipment necessary to perform the contract work needed for the project.
4. Low bidders must be financially responsible for performing the work as bid. If requested, additional financial information must be provided. (\$250,000 or over only)
5. For projects with a bid value of \$50,000 or more, furnish three (3) references from architects, owners, or owner's agents indicating satisfactory and timely completion of prior work (no older than 3 years).
6. Low bidders must demonstrate, if requested, that on previous state projects, the bidder complied in good faith with the requirements of listing subcontractors per Sections 4b-93 and 4b-95 of the Connecticut General Statutes.
7. Low bidders must demonstrate that all major required subcontractors, per Section 4b-95 of the Connecticut General Statutes, who are declared in the bid documents, are in compliance with the provisions of Section 20-341gg of the Connecticut General Statutes concerning licensure if work is to be performed on any structure that exceeds the threshold limits in Section 29-276b of the Connecticut General Statutes, as revised.
8. Low bidders must have demonstrated the skill, ability and integrity necessary for faithful performance on state and other projects relative to past honesty and sincerity in relationships with client agencies and other owners. Review of Agency files shall be included in the evaluation of bidder's qualifications and anticipated future performance.
9. All serious or willful violations of OSHA regulations in the past three (3) years nor have received a criminal conviction related to the injury or death of any employee in the three (3) year period preceding the bid.
10. All legal or administrative proceedings, currently pending, as well as any which have concluded adversely within the last three years which relate to performance of any public or private construction contracts.

11. Have demonstrated a good track record of past performance on state or other projects relative to the quantity, quality, timeliness, cost, cooperation and harmonious working relationships with subcontractors, suppliers and client agencies. Prompt payment to subcontractors and suppliers is a critical factor to be considered.
12. Identify any situations where the bidder failed to complete a construction contract or situations where bonds were called during the past three years. If so, note when, where, and attach a separate sheet of explanation to this form.
13. Not have been found to be currently in major violation of tax law compliance requirements of the Department of Revenue Services.
14. Not have been found to be currently in major violation of labor laws as required through the Department of Labor including violations of prevailing wage laws in the past three years.

## BIDDERS' QUALIFICATION STATEMENT

PROJECT NO. \_\_\_\_\_

All bidders are required to file this form, properly completed, WITH THEIR PROPOSAL. Failure of a bidder to answer any question or provide required information may be grounds for the awarding authority to disqualify and reject their bid. If a question or request for information does not pertain to your organization in any way, use the symbol "NA" (Not Applicable). Use additional 8 1/2 x 11 sheets with your letterhead as necessary.

1. Indicate exactly the name by which this organization is known:  
Name \_\_\_\_\_.
2. How many years has this organization been in business under its present business name?  
Years \_\_\_\_\_.
3. How many years has this organization been in business as a General Contractor?  
Years \_\_\_\_\_.
4. If this organization has not always been a General Contractor, list the trade(s) that your firm customarily performed prior to the time that you became a General Contractor:
  1. \_\_\_\_\_,
  2. \_\_\_\_\_,
  3. \_\_\_\_\_.
5. Indicate all other names by which this organization has been known and the length of time known by each name:
  1. \_\_\_\_\_,
  2. \_\_\_\_\_,
  3. \_\_\_\_\_.
6. This firm is a : \_\_\_\_\_ Corporation, \_\_\_\_\_ Partnership,  
\_\_\_\_\_ Sole Proprietorship, \_\_\_\_\_ Joint Venture, \_\_\_\_\_ Other.
7. Attach resumes of all supervisory personnel, such as Principals, Project Managers, and Superintendents who will be directly involved with projects on which you are now a bidder. Indicate the number of years of construction experience and the number of years which were in a Supervisory capacity.
8. List all sub-trades which your firm customarily performs with own employees.
  1. \_\_\_\_\_,
  2. \_\_\_\_\_,
  3. \_\_\_\_\_.
9. Trade References: Names, addresses, and telephone numbers of several firms with whom your organization has regular business dealings:

(Attach Separate Sheet)

10. All Construction Projects your organization has in process:

<u>TITLE &amp; LOCATION</u>	<u>CONTRACT AMOUNT</u>	<u>OWNER</u>	<u>DESIGNER</u>	<u>START DATE</u>	<u>FINISH DATE</u>	<u>ANY COMPLAINT AS TO QUALITY OF MANAGEMENT</u>	<u>NAME &amp; PHONE OF OWNER'S REP</u>	<u>NAME &amp; PHONE OF DESIGNER'S REP</u>
-----------------------------	------------------------	--------------	-----------------	-------------------	--------------------	--	--	---

Please attach a separate sheet explaining any negative entry in the last three columns.

11. All Construction Projects your organization has completed in the past five years or the twenty projects most recently completed:

<u>TITLE &amp; LOCATION</u>	<u>CONTRACT AMOUNT</u>	<u>OWNER</u>	<u>DESIGNER</u>	<u>START DATE</u>	<u>FINISH DATE</u>	<u>ANY COMPLAINT AS TO QUALITY OF MANAGEMENT</u>	<u>NAME &amp; PHONE OF OWNER'S REP</u>	<u>NAME &amp; PHONE OF DESIGNER'S REP</u>
-----------------------------	------------------------	--------------	-----------------	-------------------	--------------------	--	--	---

Please attach a separate sheet explaining any negative entry in the last three columns.

**BIDDERS QUALIFICATION STATEMENT**

- 12. Has your organization ever failed to complete a contract, or has any officer or partner of your organization ever been an officer or partner of another organization that failed to complete a contract? If so, indicate the circumstances leading to the project failure and the name of the company which provided the bonding for the failed contract(s):

---

---

---

---

---

- 13. List all legal or administrative proceedings currently pending or concluded adversely within the last five years which relate to procurement or performance of any public or private construction contracts. (Exclude OSHA violations which are called for elsewhere in this statement.)

1.  Attached                      2.  Not Applicable

- 14. List all willful or serious violations of any Occupational Safety and Health Act (OSHA) or of any standard, order or regulation promulgated pursuant to such act, during the three year period preceding the bid, provided such violations were cited in accordance with the provisions of any State Occupational Safety and Health Act or Occupational Safety and Health Act of 1970. Indicate whether these were abated within the time fixed by the citation or whether the citation was appealed. If appealed, what is the status or disposition.

1.

2.

3.

15. Has your organization had any criminal convictions related to the injury or death of any employee in the three year period preceding the bid. Please list any such convictions below.

1.

2.

Dated at \_\_\_\_\_  
this \_\_\_\_\_ day of \_\_\_\_\_, 2020.

Name of Organization:  
\_\_\_\_\_

Signature \_\_\_\_\_  
Print Name \_\_\_\_\_  
Title \_\_\_\_\_

NOTARY STATEMENT:

Mr./Ms. \_\_\_\_\_ being duly sworn deposes and says that  
he/she is the \_\_\_\_\_ of  
(Position or Title)  
\_\_\_\_\_, and that the answers to the  
(Firm Name)  
foregoing questions and all statements therein contained are true and correct.

Subscribed and sworn before me this \_\_\_\_\_ day of \_\_\_\_\_, 2020.

Notary Public: \_\_\_\_\_

My Commission expires \_\_\_\_\_, 2020.  
(Seal Required)

**NOTICE TO BIDDERS**  
EASTERN CONNECTICUT STATE UNIVERSITY

1. **BIDS AND REJECTION OF BIDS:** Bids shall be for the complete work as specified and shall include the names of any subcontractors for the four classes of work specified in subsection (a) of Section 4b-93 of the General Statutes of Connecticut as revised, and for each other class of work for which the awarding authority has required a separate section pursuant to said subsection and the dollar amounts of their subcontracts, and the contractor shall be selected on the basis of such bids. It shall be presumed that the bidder intends to perform with its own employees all work in such four classes and such other classes, for which no subcontractor is named. The bidder's qualifications for performing such work shall be subject to review under Section 4b-92 of the General Statutes of Connecticut, as revised.

Every general bid, which is on a form not completely filled in or which is incomplete, conditional or obscure, or which contains any addition not called for shall be invalid; and the awarding authority shall reject every such bid. The awarding authority shall be authorized to waive minor irregularities which he considers in the best interest of the state, provided the reasons for any such waiver are stated in writing by the awarding authority and made a part of the contract file. No such bid shall be rejected because of the failure to submit prices for, or information relating to, any item or items for which no specific space is provided in the bid form furnished by the awarding authority, but this sentence shall not be applicable to any failure to furnish prices or information required by Section 4b-95 of the General Statutes of Connecticut, as revised, to be furnished in the bid form provided by the awarding authority.

Bids shall be publicly opened and read by the awarding authority forthwith. The awarding authority may require in the bid form that the contractor agree to perform a stated, minimum percentage of work with its own forces. The awarding authority may also require the contractor to set aside a portion of the contract for subcontractors who are eligible for set-aside contracts. The awarding authority shall not permit substitution of a subcontractor for one named in accordance with the provisions of said Section 4b-95 or substitution of a subcontractor for any designated subtrade work bid to be performed by the contractor's own forces, except for good cause. The term "good cause" includes but is not limited to a subcontractor's or, where appropriate, a contractor's: (1) death or physical disability, if the listed subcontractor is an individual; (2) dissolution, if a corporation or partnership; (3) bankruptcy; (4) inability to furnish any performance and payment bond shown on the bid form; (5) inability to obtain, or loss of, a license necessary for the performance of the particular category of work; (6) failure or inability to comply with a requirement of law applicable to contractors, subcontractors, or construction, alteration, or repair projects; (7) failure to perform his agreement to execute a subcontract under Section 4b-96 of the General Statutes of Connecticut, as revised.

The bid price shall be the price set forth in the space provided on the bid form. No bid shall be rejected (1) because of error in setting forth the name of a subcontractor as long as the subcontractor or subcontractors designated are clearly identifiable, or (2) because the plans and specifications do not accompany the bid or are not submitted with the bid. Failure to correctly state a subcontractor's price shall be a cause for rejection of the bid.

Any contractor who violates any provision of said Section 4b-95 may be disqualified from bidding on other contracts that are subject to the provisions of Chapter 60 of the General Statutes of Connecticut, as revised, for a period not to exceed twenty-four months, commencing from the date on which the violation is discovered, for each violation. The

awarding authority shall periodically review the contractor's subcontracts to insure compliance with such provisions and shall, after each such review, prepare a written report setting forth his findings and conclusions.

Bids shall be submitted only on the forms furnished for the specific project. In no event will bids or changes in bids made by telephone, telegraph, or facsimile be considered. Any bid form omitting or adding items, altering the form, containing conditional or alternative bids, not filled in completely or without the original signature of the bidder or its authorized representative, will be rejected.

Any bid received after the scheduled closing time for the receipt of bids will be returned to the bidder unopened.

Any bid, once deposited with the agency, may only be withdrawn by letter of request, signed by the depositing bidder and presented to the Acquisitions Specialist, prior to the time of opening of any bid for the project designated or identified project.

2. BID SECURITY: Each bid must be accompanied by a certified check payable to the order of the University, or the bid may be accompanied by a bid bond, in the form required by the awarding authority, having as surety thereto such surety company or companies acceptable to the agency and as are authorized to do business in this State, for an amount not less than 10 percent of the bid. All checks submitted by unsuccessful bidders shall be returned to them after the contract has been awarded.
3. FORFEITURE OF BID SECURITY: Failure of the successful bidder to execute a contract awarded as specified and bid shall result in the forfeiture of the bid bond or certified check.
4. ADDENDA AND INTERPRETATIONS: No interpretations of the meaning of the plans, specifications or other contract documents will be made orally to any bidder. Every request for such interpretation should be in writing to the awarding authority and, to be given consideration, must be received at least ten (10) days prior to the date fixed for the opening of bids. Any and all such interpretations and any supplemental instructions will be in the form of written addenda to the specifications which, if issued, will be mailed to all prospective bidders (at the respective addresses furnished for such purposes) not later than five (5) days prior to the date fixed for the opening of bids. Failure of any bidder to receive any such addendum or interpretation shall not release any bidder from any obligations under his bid as submitted, provided notice has been sent to the address furnished by such prospective bidder for the transmittal of notices, addenda and interpretations. It shall be the bidder's responsibility to make inquiry as to, and to obtain, the addenda issued, if any.
5. EXECUTIVE ORDER NO. THREE:

This contract is subject to the provisions of Executive Order No. Three of Governor Thomas J. Meskill promulgated June 16, 1971, and, as such, this contract may be canceled, terminated or suspended by the State Labor Commissioner for violation of or noncompliance with said Executive Order No. Three, or any state or federal law concerning nondiscrimination, notwithstanding that the Labor Commissioner is not a party to this contract. The parties to this contract, as part of the consideration hereof, agree that said Executive Order No. Three is incorporated herein by reference and made a part hereof. The parties agree to abide by said Executive Order and agree that the State Labor Commissioner shall have continuing jurisdiction in respect to contract

performance in regard to nondiscrimination until the contract is completed or terminated prior to completion.

The contractor agrees, as part consideration hereof, that this contract is subject to the Guidelines and Rules issued by the State Labor Commissioner to implement Executive Order No. Three, and that he will not discriminate in his employment practices or policies, will file all reports as required, and will fully cooperate with the State of Connecticut and the State Labor Commissioner.

6. EXECUTIVE ORDER NO. SIXTEEN:

This contract is subject to the provisions of Executive Order No. Sixteen of Governor John G. Rowland promulgated August 4, 1999, and, as such, the contract may be canceled, terminated or suspended by the state for violation of or noncompliance with said Executive Order No. Sixteen. The parties to this contract, as part of the consideration hereof, agree that said Executive Order No. Sixteen is incorporated herein by reference and made a part hereof. The parties agree to abide by such Executive Order.

7. EXECUTIVE ORDER NO. SEVENTEEN:

This contract is subject to the provisions of Executive Order No. Seventeen of Governor Thomas J. Meskill promulgated February 15, 1973, and, as such, this contract may be canceled, terminated or suspended by the contracting agency or the State Labor Commissioner for violation of or noncompliance with said Executive Order No. Seventeen, notwithstanding that the Labor Commissioner may not be a party to this contract. The parties to this contract, as part of the consideration hereof, agree that Executive Order No. Seventeen is incorporated herein by reference and made a part hereof. The parties agree to abide by said Executive Order and agree that the contracting agency and the State Labor Commissioner shall have joint and several continuing jurisdiction in respect to contract performance in regard to listing all employment openings with the Connecticut State Employment Service.

8. FOREIGN CORPORATIONS: A corporation not organized under the laws of this State that is awarded the contract must comply with the laws of this State regarding the procurement of a certificate of authority to transact business in this State from the Secretary of State.

9. SECURITY FOR FAITHFUL PERFORMANCE:

A. Performance Bond. On or before the contract award date the successful bidder, for any bid equal to or exceeding \$50,000, shall substitute for the certified check or bid bond accompanying his bid, an executed Performance Bond, in an amount not less than 100 percent of the contract price, conditioned upon the faithful performance of the contract, and having as surety thereto such Surety Company or Companies satisfactory to the Agency and as are authorized to transact business in this State.

B. Labor and Material Bond. At this same time the successful bidder, for any bid equal to or exceeding \$50,000, shall submit a labor and material bond in an amount not less than 100 percent of the contract price which shall be binding upon the award of the contract to such bidder, with surety or sureties satisfactory to the Agency and as are authorized to transact business in this State, for the

protection of persons supplying labor or materials in the prosecution of the work provided for in the contract for the use of each such person. Any such bond furnished shall have as principal the name of the successful bidder. This bond is to be furnished pursuant to Section 49-41 of the General Statutes of Connecticut, as revised. The following sections of the General Statutes of Connecticut, as revised, are inserted as information concerning this bond.

Sec. 49-41a. Enforcement of payment by general contractor to subcontractor and by subcontractor to his subcontractors.

(a) When any public work is awarded by a contract for which a payment bond is required by Section 49-41, the contract for the public work shall contain the following provisions: (1) a requirement that the general contractor, within thirty days after payment to the contractor by the State or a municipality, pay any amounts due any subcontractor, whether for labor performed or materials furnished, when the labor or materials have been included in a requisition submitted by the contractor and paid by the State or a municipality; (2) a requirement that the general contractor shall include in each of its subcontracts a provision requiring each subcontractor to pay any amounts due any of its subcontractors, whether for labor performed or materials furnished, within thirty days after such subcontractor receives a payment from the general contractor which encompasses labor or materials furnished by such subcontractor.

(b) If payment is not made by the general contractor or any of its subcontractors in accordance with such requirements, the subcontractor shall set forth his claim against the general contractor and the subcontractor of a subcontractor shall set forth its claim against the subcontractor through notice by registered or certified mail. Ten days after the receipt of that notice, the general contractor shall be liable to its subcontractor, and the subcontractor shall be liable to its subcontractor, for interest on the amount due and owing at the rate of one percent per month. In addition, the general contractor, upon written demand of its subcontractor, or the subcontractor, upon written demand of its subcontractor, shall be required to place funds in the amount of the claim, plus interest of one percent, in any interest-bearing escrow account in a bank in this state, provided the general contractor or subcontractor may refuse to place the funds in escrow on the grounds that the subcontractor has not substantially performed the work according to the terms of his or its employment. In the event that such general contractor or subcontractor refuses to place such funds in escrow, and the party making a claim against it under this section is found to have substantially performed its work in accordance with the terms of its employment in any arbitration or litigation to determine the validity of such claim, then such general contractor or subcontractor shall pay the attorney's fees of such party.

(c) No payment may be withheld from a subcontractor for work performed because of a dispute between the general contractor and another contractor or subcontractor.

(d) This section shall not be construed to prohibit progress payments prior to final payment of the contract and is applicable to all subcontractors for material or labor whether they have contracted directly with the general contractor or with some other subcontractor on the work.

Section 49-42. Enforcement of right to payment on bond. Suit on bond; when

and how brought.

(a) Any person who performed work or supplied materials for which a requisition was submitted to, or for which an estimate was prepared by, the awarding authority and who does not receive full payment for such work or materials within sixty days of the applicable payment date provided for in Subsection (a) of Section 49-41a, or any person who supplied materials or performed subcontracting work not included on a requisition or estimate who has not received full payment for such materials or work within sixty days after the date such materials were supplied or such work was performed, may enforce his right to payment under the bond by serving a notice of claim on the surety that issued the bond and a copy of such notice to the contractor named as principal in the bond within one hundred eighty days of the applicable payment date provided for in Subsection (a) of Section 49-41a, or, in the case of a person supplying materials or performing subcontracting work not included on a requisition or estimate, within one hundred eighty days after the date such materials were supplied or such work was performed. The notice of claim shall state with substantial accuracy the amount claimed and the name of the party for whom the work was performed or to whom the materials were supplied, and shall provide a detailed description of the bonded project for which the work or materials were provided. If the content of a notice prepared in accordance with Subsection (b) of Section 49-41a complied with the requirements of this section, a copy of such notice, served within one hundred eighty days of the payment date provided for in Subsection (a) of Section 49-41a upon the surety that issued the bond and upon the contractor named as principal in the bond, shall satisfy the notice requirements of this section. Within ninety days after service of the notice of claim, the surety shall make payment under the bond and satisfy the claim, or any portion of the claim which is not subject to a good faith dispute, and shall serve a notice on the claimant denying liability for any unpaid portion of the claim. The notices required under this section shall be served by registered or certified mail, postage prepaid in envelopes addressed to any office at which the surety, principal or claimant conducts his business, or in any manner in which civil process may be served. If the surety denies liability on the claim, or any portion thereof, the claimant may bring action upon the payment bond in the superior court for such sums and prosecute the action to final execution and judgment. An action to recover on a payment bond under this section shall be privileged with respect to assignment for trial. The court shall not consolidate for trial any action brought under this section with any other action brought on the same bond unless the court finds that a substantial portion of the evidence to be adduced, other than the fact that the claims sought to be consolidated arise under the same general contract, is common to such actions and that consolidation will not result in excessive delays to any claimant whose action was instituted at a time significantly prior to the motion to consolidate. In any such proceeding, the court judgment shall award the prevailing party the costs for bringing such proceeding and allow interest at the rate of interest specified in the labor or materials contract under which the claim arises or, if no such interest rate is specified, at the rate of interest as provided in Section 37-3a upon the amount recovered, computed from the date of service of the notice of claim, provided, for any portion of the claim which the court finds was due and payable after the date of service of the notice of claim, such interest shall be computed from the date such portion became due and payable. The court judgment may award reasonable attorneys fees to either party if upon reviewing the entire record, it appears that either the original claim, the surety's denial of liability, or the defense interposed to the

claim is without substantial basis in fact or law. Any person having direct contractual relationship with a subcontractor but no contractual relationship express or implied with the contractor furnishing the payment bond shall have a right of action upon the payment bond upon giving written notice of claim as provided in this section.

(b) Every suit instituted under this section shall be brought in the name of the person suing, in the superior court for the judicial district where the contract was to be performed, irrespective of the amount in controversy in the suit, but no such suit may be commenced after the expiration of one year after the applicable payment date provided for in Subsection (a) of Section 49-41a, or, in the case of a person supplying materials or performing subcontracting work not included on a requisition or estimate, no such suit may be commenced after the expiration of one year after the date such materials were supplied or such work was performed.

(c) The word "material" as used in Section 49-41 to 49-43, inclusive, includes the rental of equipment used in the prosecution of work provided for in the contract.

10. CONNECTICUT SALES AND USE TAXES: All bidders shall familiarize themselves with the current regulations of the Department of Revenue Service. The tax on materials or supplies exempted by such statutes and regulations shall not be included as part of a bid.

Nonresident contractors must comply with the provisions of Connecticut General Statutes Section 12-430(7), bond requirement for nonresident contractors, and the regulations established pursuant to that section.

11. CONTRACTOR'S QUALIFICATIONS: All bidders shall file with their bids a statement of qualifications on the appropriate form.

12. SUBCONTRACTORS: (a) As required by the project data sheet, each bidder shall furnish with his submitted bid, and in the place on the bid form provided for such purpose, the names of responsible and qualified subcontractors who are actually to perform the work required by the division or portion of the specifications listed, for the base bid. Failure to so list a subcontractor for any division or portion of the specifications will result in rejection of the entire bid.

13. WORKING DAY: A working day is hereby defined as each consecutive day, including and following the date set for commencement of work, except Saturdays, Sundays and state legal holidays and except those days on which, in the opinion of the awarding authority, the Contractor is prevented by inclement weather from proceeding with work on the major items under construction at the then current stage of the work at least six (6) hours with the usual force employed on these major items, provided however, that in the event the State directs or permits work to be performed on a Saturday, Sunday or a state legal holiday, then such day shall be considered a working day.

14. NONDISCRIMINATION AND AFFIRMATIVE ACTION PROVISIONS:

This section is inserted in connection with Subsection (a) of Section 4a-60 of the General Statutes of Connecticut, as revised.

- A. For the purposes of this section, "minority business enterprise" means any small contractor or supplier of materials, fifty-one percent or more of the capital stock, if any, or assets of which is owned by a person or persons: (1) who are active in the daily affairs of the enterprise, (2) who have the power to direct the management and policies of the enterprise and (3) who are member of a minority, as such term is defined in Subsection (a) of Connecticut General Statutes, Section 32-9n; and "good faith" means that degree of diligence which a reasonable person would exercise in the performance of legal duties and obligations. "Good faith efforts" shall include, but not be limited to, those reasonable initial efforts necessary to comply with statutory or regulatory requirements and additional or substituted efforts when it is determined that such initial efforts will not be sufficient to comply with such requirements.

For the purpose of this section, "commission" means the Commission on Human Rights and Opportunities.

For the purpose of this section, "public works contract" means any agreement between any individual, firm or corporation and the state or any political subdivision of the state other than a municipality for construction, rehabilitation, conversion, extension, demolition or repair of a public building, highway or other changes or improvements in real property, of which is financed in whole or in part by the state, including, but not limited to, matching expenditures, grants, loans, insurance or guarantees.

- B. (1) The contractor agrees and warrants that in the performance of the contract such contractor will not discriminate or permit discrimination against any person or group of persons on the grounds of race, color, religious creed, age, marital status, national origin, ancestry, sex, mental retardation or physical disability, including, but not limited to, blindness, unless it is shown by such contractor that such disability prevents performance of the work involved, in any manner prohibited by the laws of the United States or of the State of Connecticut. The contractor further agrees to take affirmative action to insure that applicants with job-related qualifications are employed and that employees are treated when employed without regard to their race, color, religious creed, age, marital status, national origin, ancestry, sex, mental retardation, or physical disability, including, but not limited to, blindness, unless it is shown by such contractor that such disability prevents performance of the work involved; (2) the contractor agrees, in all solicitations or advertisements for employees placed by or on behalf of the contractor, to state that it is an "affirmative action/equal opportunity employer" in accordance with regulations adopted by the commission; (3) the contractor agrees to provide each labor union or representative of workers with which such contractor has a collective bargaining agreement or other contract or understanding and each vendor with which such contractor has a contract or understanding, a notice to be provided by the commission advising the labor union or workers' representative of the contractor's commitments under this section, and to post copies of the notice in conspicuous places available to employees and applicants for employment; (4) the contractor agrees to comply with each provision of this section and Connecticut General Statutes Sections 46a-68e and 46a-68f and with each regulation or relevant order issued by said commission pursuant to Connecticut General Statutes Sections 46a-56, 46a-68e, and 46a-68f; (5) the contractor agrees to provide the Commission on Human Rights and Opportunities with such information requested by the commission and permit access to pertinent books, records and accounts, concerning the

employment practices and procedures of the contractor as relate to the provisions of this section and Connecticut General Statutes Section 46a-56. If the contract is a public works contract, the contractor agrees and warrants that he will make good faith efforts to employ minority business enterprises as subcontractors and suppliers of materials on such public works projects.

- C. Determination of the contractor's good faith efforts shall include, but shall not be limited to, the following factors: The contractor's employment and subcontracting policies, patterns and practices; affirmative advertising, recruitment and training; technical assistance activities and such other reasonable activities or efforts as the commission may prescribe that are designed to ensure the participation of minority business enterprises in public works projects.
- D. The contractor shall develop and maintain adequate documentation, in a manner prescribed by the commission, of its good faith efforts.
- E. The contractor shall include the provisions of subsection (b) of this section in every subcontract or purchase order entered into in order to fulfill any obligation of a contract with the state and such provisions shall be binding on a subcontractor, vendor, or manufacturer unless exempted by regulations or orders of the Commission. The contractor shall take such action with respect to any such subcontract or purchase order as the Commission may direct as a means of enforcing such provisions including sanctions for noncompliance in accordance with Connecticut General Statutes Section 46a-56; provided if such contractor becomes involved in, or is threatened with, litigation with a subcontractor or vendor as a result of such direction by the Commission, the contractor may request the State of Connecticut to enter into any such litigation or negotiation prior thereto to protect the interests of the state and the state may so enter.
- F. The contractor agrees to comply with the regulations referred to in this section as they exist on the date of this contract and as they may be adopted or amended from time to time during the term of this contract and any amendments thereto.

15. NONDISCRIMINATION PROVISIONS REGARDING SEXUAL ORIENTATION:

This section is inserted in connection with Subsection (a) of Section 4a-60a of the General Statutes of Connecticut, as revised.

- A. (1) The contractor agrees and warrants that in the performance of the contract such contractor will not discriminate or permit discrimination against any person or group of persons on the grounds of sexual orientation, in any manner prohibited by laws of the United States or of the State of Connecticut, and that employees are treated when employed without regard to their sexual orientation; (2) the contractor agrees to provide each labor union or representative of workers with which such contractor or understanding and each vendor with which such contractor has a collective bargaining agreement or other contract or understanding and each vendor with which such contractor has a contract or understanding, a notice to be provided by the Commission on Human Rights and Opportunities advising the labor union or workers' representative of the contractor's commitment under this section, and to post copies of the notice in conspicuous places available to employees and applicants for employment; (3) the contractor agrees to comply with each provision of this section and with each regulation or relevant order issued by said commission pursuant to Section 46a-

56 of the general statutes; (4) the contractor agrees to provide the Commission on Human Rights and Opportunities with such information requested by the commission, and permit access to pertinent books, records and accounts, concerning the employment practices and procedures of the contractor which relate to the provisions of this section and Section 46a-56 of the General Statutes.

- B. The contractor shall include the provisions of Subsection a of this section in every subcontract or purchase order entered into in order to fulfill any obligation of a contract with the state and such provisions shall be binding on a subcontractor, vendor or manufacturer unless exempted by regulations or orders of the commission. The contractor shall take such action with respect to any such subcontract or purchase order as the commission may direct as a means of enforcing such provisions including sanctions for noncompliance in accordance with Section 46a-56 of the General Statutes; provided, if such contractor becomes involved in, or is threatened with, litigation with a subcontractor or vendor as a result of such direction by the commission, the contractor may request the State of Connecticut to enter into any such litigation or negotiation prior thereto to protect the interests of the state and the state may so enter.

16. AGREEMENT TO ARBITRATE: Any dispute arising out of the awarding of the contract for this project by the Agency, or performance thereunder, shall be submitted to arbitration under the rules of the American Arbitration Association. Hartford, Connecticut, shall be the locale where the Arbitration is to be held.
17. UNION LABOR: Attention is called to the fact that there may be construction work now being carried on at the site at which this construction is contemplated being done by union labor. This fact must be kept in mind by all bidders.
18. LABOR MARKET AREA:

All bidders shall have read Sections 31-52 and 31-52a of the Connecticut General Statutes, as revised. These sections relate to the preference of State citizens and the preference of residents of the labor market area in which the work under the contract is to be done and the penalties for violations thereof.

In order to avoid violations by the contractor and to cooperate with and assist the State in the implementation of the statutory mandates, any contractor bidder awarded a contract with the State shall be required to provide the State with the following information:

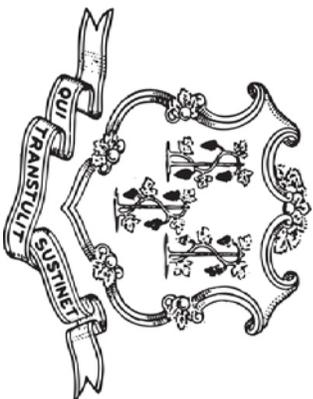
- A. The names and addresses of employees utilized by the contractor and by its subcontractors and how long each such employee has resided in Connecticut.
- B. How long each employee has resided in the labor market area, as established by the State Labor Commissioner, in which the work under the contract is to be done. Labor market areas are indicated on the attached map.
- C. Within thirty (30) days after the start of work, the contractor shall submit a signed statement setting forth the procedures the contractor and its subcontractors have taken to assure that they have sought out qualified residents of the labor market area. Also, the statement shall include information as to how many persons were considered for employment and how many were actually hired. Such procedures

will include, but not be limited to, obtaining names of available persons from area Employment Security Offices.

- D. In the same manner as Item (C) above, the statement shall indicate the steps taken to assure that the contractor and its subcontractors have sought out qualified residents of this state.
- E. The contractor shall cooperate with and provide information to the construction supervisor or inspector of the State assigned to collect and verify the information required. The State may request that all such information be updated during the term of the contract at reasonable times.
- F. All such information gathered and compiled by the State shall be forwarded to the Labor Commissioner.

Pursuant to Section 31-52b of the Connecticut General Statutes, as revised:  
"The provisions of Sections 31-52 and 31-52a shall not apply where the state or any subdivision thereof may suffer the loss of revenue granted or to be granted from any agency or department of the federal government as a result of said sections or regulative procedures pursuant thereto." However, no exception shall be determined to be applicable unless stated in writing from the Agency.

## **PREVAILING WAGE RATES**



# **THIS IS A PUBLIC WORKS PROJECT**

**Covered by the**

# **PREVAILING WAGE LAW**

**CT General Statutes Section 31-53**

**If you have QUESTIONS regarding your wages**  
**CALL (860) 263-6790**

Section 31-55 of the CT State Statutes requires every contractor or subcontractor performing work for the state to post in a prominent place the prevailing wages as determined by the Labor Commissioner.

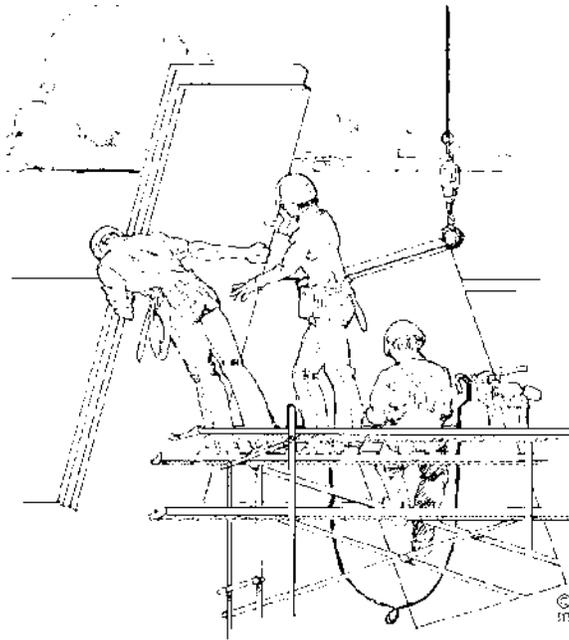
~NOTICE~

TO ALL CONTRACTING AGENCIES

Please be advised that Connecticut General Statutes Section 31-53, requires the contracting agency to certify to the Department of Labor, the total dollar amount of work to be done in connection with such public works project, regardless of whether such project consists of one or more contracts.

Please find the attached “Contracting Agency Certification Form” to be completed and returned to the Department of Labor, Wage and Workplace Standards Division, Public Contract Compliance Unit.

 Inquiries can be directed to (860)263-6543.



CONNECTICUT DEPARTMENT OF LABOR  
WAGE AND WORKPLACE STANDARDS DIVISION  
CONTRACT COMPLIANCE UNIT

*CONTRACTING AGENCY CERTIFICATION FORM*

I, \_\_\_\_\_, acting in my official capacity as \_\_\_\_\_,  
authorized representative title

for \_\_\_\_\_, located at \_\_\_\_\_,  
contracting agency address

do hereby certify that the total dollar amount of work to be done in connection with  
\_\_\_\_\_, located at \_\_\_\_\_,  
project name and number address

shall be \$\_\_\_\_\_, which includes all work, regardless of whether such project  
consists of one or more contracts.

*CONTRACTOR INFORMATION*

Name: \_\_\_\_\_

Address: \_\_\_\_\_

Authorized Representative: \_\_\_\_\_

Approximate Starting Date: \_\_\_\_\_

Approximate Completion Date: \_\_\_\_\_

\_\_\_\_\_  
Signature

\_\_\_\_\_  
Date

Return To: Connecticut Department of Labor  
Wage & Workplace Standards Division  
Contract Compliance Unit  
200 Folly Brook Blvd.  
Wethersfield, CT 06109

Date Issued: \_\_\_\_\_

CONNECTICUT DEPARTMENT OF LABOR  
WAGE AND WORKPLACE STANDARDS DIVISION

**CONTRACTORS WAGE CERTIFICATION FORM**  
**Construction Manager at Risk/General Contractor/Prime Contractor**

I, \_\_\_\_\_ of \_\_\_\_\_  
Officer, Owner, Authorized Rep. Company Name

do hereby certify that the \_\_\_\_\_  
Company Name  
\_\_\_\_\_  
Street  
\_\_\_\_\_  
City

and all of its subcontractors will pay all workers on the  
\_\_\_\_\_  
Project Name and Number  
\_\_\_\_\_  
Street and City

the wages as listed in the schedule of prevailing rates required for such project (a copy of which is attached hereto).

\_\_\_\_\_  
Signed

Subscribed and sworn to before me this \_\_\_\_\_ day of \_\_\_\_\_, \_\_\_\_\_.

\_\_\_\_\_  
Notary Public

Return to:  
Connecticut Department of Labor  
Wage & Workplace Standards Division  
200 Folly Brook Blvd.  
Wethersfield, CT 06109

Rate Schedule Issued (Date): \_\_\_\_\_



Weekly Payroll Certification For  
Public Works Projects (Continued)

**PAYROLL CERTIFICATION FOR PUBLIC WORKS PROJECTS**  
**WEEKLY PAYROLL**

Week-Ending Date:  
Contractor or Subcontractor Business Name:

PERSON/WORKER, ADDRESS and SECTION	APPR RATE %	MALE/ FEMALE AND RACE*	WORK CLASSIFICATION Trade License Type & Number - OSHA 10 Certification Number	DAY AND DATE							Total ST Hours	Base Hourly RATE	TOTAL FRINGE BENEFIT PLAN CASH	TYPE OF FRINGE BENEFITS Per Hour 1 through 6 (see back)	GROSS PAY FOR ALL WORK PERFORMED THIS WEEK	TOTAL DEDUCTIONS			GROSS PAY FOR THIS PREVAILING RATE JOB	CHECK # AND NET PAY				
				S	M	T	W	TH	F	S						FEDERAL	STATE	OTHER						
				HOURS WORKED EACH DAY												O/T Hours	FICA	WITH- HOLDING			WITH- HOLDING			
											\$	1. \$												
											Base Rate	2. \$												
											\$	3. \$												
											Base Rate	4. \$												
											\$	5. \$												
											Cash Fringe	6. \$												
											\$	1. \$												
											Base Rate	2. \$												
											\$	3. \$												
											Base Rate	4. \$												
											\$	5. \$												
											Cash Fringe	6. \$												
											\$	1. \$												
											Base Rate	2. \$												
											\$	3. \$												
											Base Rate	4. \$												
											\$	5. \$												
											Cash Fringe	6. \$												
											\$	1. \$												
											Base Rate	2. \$												
											\$	3. \$												
											Base Rate	4. \$												
											\$	5. \$												
											Cash Fringe	6. \$												

\*IF REQUIRED

12/9/2013  
WWS-CP2

NOTICE: THIS PAGE MUST BE ACCOMPANIED BY A COVER PAGE (FORM # WWS-CP1)

PAGE NUMBER \_\_\_\_\_ OF \_\_\_\_\_

**\*FRINGE BENEFITS EXPLANATION (P):**

Bona fide benefits paid to approved plans, funds or programs, except those required by Federal or State Law (unemployment tax, worker’s compensation, income taxes, etc.).

Please specify the type of benefits provided:

- 1) Medical or hospital care \_\_\_\_\_ 4) Disability \_\_\_\_\_
- 2) Pension or retirement \_\_\_\_\_ 5) Vacation, holiday \_\_\_\_\_
- 3) Life Insurance \_\_\_\_\_ 6) Other (please specify) \_\_\_\_\_

**CERTIFIED STATEMENT OF COMPLIANCE**

For the week ending date of \_\_\_\_\_,

I, \_\_\_\_\_ of \_\_\_\_\_, (hereafter known as Employer) in my capacity as \_\_\_\_\_ (title) do hereby certify and state:

**Section A:**

1. All persons employed on said project have been paid the full weekly wages earned by them during the week in accordance with Connecticut General Statutes, section 31-53, as amended. Further, I hereby certify and state the following:

- a) The records submitted are true and accurate;
- b) The rate of wages paid to each mechanic, laborer or workman and the amount of payment or contributions paid or payable on behalf of each such person to any employee welfare fund, as defined in Connecticut General Statutes, section 31-53 (h), are not less than the prevailing rate of wages and the amount of payment or contributions paid or payable on behalf of each such person to any employee welfare fund, as determined by the Labor Commissioner pursuant to subsection Connecticut General Statutes, section 31-53 (d), and said wages and benefits are not less than those which may also be required by contract;
- c) The Employer has complied with all of the provisions in Connecticut General Statutes, section 31-53 (and Section 31-54 if applicable for state highway construction);
- d) Each such person is covered by a worker’s compensation insurance policy for the duration of his employment which proof of coverage has been provided to the contracting agency;
- e) The Employer does not receive kickbacks, which means any money, fee, commission, credit, gift, gratuity, thing of value, or compensation of any kind which is provided directly or indirectly, to any prime contractor, prime contractor employee, subcontractor, or subcontractor employee for the purpose of improperly obtaining or rewarding favorable treatment in connection with a prime contract or in connection with a prime contractor in connection with a subcontractor relating to a prime contractor; and
- f) The Employer is aware that filing a certified payroll which he knows to be false is a class D felony for which the employer may be fined up to five thousand dollars, imprisoned for up to five years or both.

2. OSHA~The employer shall affix a copy of the construction safety course, program or training completion document to the certified payroll required to be submitted to the contracting agency for this project on which such persons name first appears.

\_\_\_\_\_ (Signature)                      \_\_\_\_\_ (Title)                      \_\_\_\_\_ Submitted on (Date)



**\*FRINGE BENEFITS EXPLANATION (P):**

Bona fide benefits paid to approved plans, funds or programs, except those required by Federal or State Law (unemployment tax, worker's compensation, income taxes, etc.).

Please specify the type of benefits provided:

- 1) Medical or hospital care Blue Cross 4) Disability \_\_\_\_\_
- 2) Pension or retirement \_\_\_\_\_ 5) Vacation, holiday \_\_\_\_\_
- 3) Life Insurance Utopia 6) Other (please specify) \_\_\_\_\_

**CERTIFIED STATEMENT OF COMPLIANCE**

For the week ending date of 9/26/09,

I, Robert Craft of XYZ Corporation, (hereafter known as

Employer) in my capacity as Owner (title) do hereby certify and state:

**Section A:**

1. All persons employed on said project have been paid the full weekly wages earned by them during the week in accordance with Connecticut General Statutes, section 31-53, as amended. Further, I hereby certify and state the following:

- a) The records submitted are true and accurate;
- b) The rate of wages paid to each mechanic, laborer or workman and the amount of payment or contributions paid or payable on behalf of each such employee to any employee welfare fund, as defined in Connecticut General Statutes, section 31-53 (h), are not less than the prevailing rate of wages and the amount of payment or contributions paid or payable on behalf of each such employee to any employee welfare fund, as determined by the Labor Commissioner pursuant to subsection Connecticut General Statutes, section 31-53 (d), and said wages and benefits are not less than those which may also be required by contract;
- c) The Employer has complied with all of the provisions in Connecticut General Statutes, section 31-53 (and Section 31-54 if applicable for state highway construction);
- d) Each such employee of the Employer is covered by a worker's compensation insurance policy for the duration of his employment which proof of coverage has been provided to the contracting agency;
- e) The Employer does not receive kickbacks, which means any money, fee, commission, credit, gift, gratuity, thing of value, or compensation of any kind which is provided directly or indirectly, to any prime contractor, prime contractor employee, subcontractor, or subcontractor employee for the purpose of improperly obtaining or rewarding favorable treatment in connection with a prime contract or in connection with a prime contractor in connection with a subcontractor relating to a prime contractor; and
- f) The Employer is aware that filing a certified payroll which he knows to be false is a class D felony for which the employer may be fined up to five thousand dollars, imprisoned for up to five years or both.

2. OSHA~The employer shall affix a copy of the construction safety course, program or training completion document to the certified payroll required to be submitted to the contracting agency for this project on which such employee's name first appears.

Robert Craft      owner      10/2/09  
 (Signature)      (Title)      Submitted on (Date)

**Section B: Applies to CONNDOT Projects ONLY**

That pursuant to CONNDOT contract requirements for reporting purposes only, all employees listed under Section B who performed work on this project are not covered under the prevailing wage requirements defined in Connecticut General Statutes Section 31-53.

Robert Craft      owner      10/2/09  
 (Signature)      (Title)      Submitted on (Date)

Note: CTDOL will assume all hours worked were performed under Section A unless clearly delineated as Section B WWS-CP1 as such. Should an employee perform work under both Section A and Section B, the hours worked and wages paid must be segregated for reporting purposes.

**\*\*\*THIS IS A PUBLIC DOCUMENT\*\*\*  
\*\*\*DO NOT INCLUDE SOCIAL SECURITY NUMBERS\*\*\***

## **Information Bulletin** ***Occupational Classifications***

The Connecticut Department of Labor has the responsibility to properly determine "job classification" on prevailing wage projects covered under C.G.S. Section 31-53(d).

***Note: This information is intended to provide a sample of some occupational classifications for guidance purposes only. It is not an all-inclusive list of each occupation's duties. This list is being provided only to highlight some areas where a contractor may be unclear regarding the proper classification. If unsure, the employer should seek guidelines for CTDOL.***

**Below are additional clarifications of specific job duties performed for certain classifications:**

- **ASBESTOS WORKERS**

Applies all insulating materials, protective coverings, coatings and finishes to all types of mechanical systems.

- **ASBESTOS INSULATOR**

Handle, install apply, fabricate, distribute, prepare, alter, repair, dismantle, heat and frost insulation, including penetration and fire stopping work on all penetration fire stop systems.

- **BOILERMAKERS**

Erects hydro plants, incomplete vessels, steel stacks, storage tanks for water, fuel, etc. Builds incomplete boilers, repairs heat exchanges and steam generators.

- **BRICKLAYERS, CEMENT MASONS, CEMENT FINISHERS, MARBLE MASONS, PLASTERERS, STONE MASONS, PLASTERERS. STONE MASONS, TERRAZZO WORKERS, TILE SETTERS**

Lays building materials such as brick, structural tile and concrete cinder, glass, gypsum, terra cotta block. Cuts, tools and sets marble, sets stone, finishes concrete, applies decorative steel, aluminum and plastic tile, applies cements, sand, pigment and marble chips to floors, stairways, etc.

- **CARPENTERS, MILLWRIGHTS. PILEDIVERMEN. LATHERS. RESILEINT FLOOR LAYERS, DOCK BUILDERS, DIKERS, DIVER TENDERS**

Constructs, erects, installs and repairs structures and fixtures of wood, plywood and wallboard. Installs, assembles, dismantles, moves industrial machinery. Drives piling into ground to provide foundations for structures such as buildings and bridges, retaining walls for earth embankments, such as cofferdams. Fastens wooden, metal or rockboard lath to walls, ceilings and partitions of buildings, acoustical tile layer, concrete form builder. Applies firestopping materials on fire resistive joint systems only. Installation of curtain/window walls only where attached to wood or metal studs. Installation of insulated material of all types whether blown, nailed or attached in other ways to walls, ceilings and floors of buildings. Assembly and installation of modular furniture/furniture systems. Free-standing furniture is not covered. This includes free standing: student chairs, study top desks, book box desks, computer furniture, dictionary stand, atlas stand, wood shelving, two-position information access station, file cabinets, storage cabinets, tables, etc.

- **LABORER, CLEANING**

- The clean up of any construction debris and the general (heavy/light) cleaning, including sweeping, wash down, mopping, wiping of the construction facility and its furniture, washing, polishing, and dusting.

- **DELIVERY PERSONNEL**

- If delivery of supplies/building materials is to one common point and stockpiled there, prevailing wages are not required. If the delivery personnel are involved in the distribution of the material to multiple locations within the construction site then they would have to be paid prevailing wages for the type of work performed: laborer, equipment operator, electrician, ironworker, plumber, etc.

- An example of this would be where delivery of drywall is made to a building and the delivery personnel distribute the drywall from one "stockpile" location to further sub-locations on each floor. Distribution of material around a construction site is the job of a laborer or tradesman, and not a delivery personnel.

- **ELECTRICIANS**

Install, erect, maintenance, alteration or repair of any wire, cable, conduit, etc., which generates, transforms, transmits or uses electrical energy for light, heat, power or other purposes, including the Installation or maintenance of telecommunication, LAN wiring or computer equipment, and low voltage wiring. **\*License required per Connecticut General Statutes: E-1,2 L-5,6 C-5,6 T-1,2 L-1,2 V-1,2,7,8,9.**

- **ELEVATOR CONSTRUCTORS**

Install, erect, maintenance and repair of all types of elevators, escalators, dumb waiters and moving walks. *\*License required by Connecticut General Statutes: R-1,2,5,6.*

- **FORK LIFT OPERATOR**

Laborers Group 4) Mason Tenders - operates forklift solely to assist a mason to a maximum height of nine (9) feet only.

Power Equipment Operator Group 9 - operates forklift to assist any trade, and to assist a mason to a height over nine (9) feet.

- **GLAZIERS**

Glazing wood and metal sash, doors, partitions, and 2 story aluminum storefronts. Installs glass windows, skylights, store fronts and display cases or surfaces such as building fronts, interior walls, ceilings and table tops and metal store fronts. Installation of aluminum window walls and curtain walls is the "joint" work of glaziers and ironworkers, which require equal composite workforce.

- **IRONWORKERS**

Erection, installation and placement of structural steel, precast concrete, miscellaneous iron, ornamental iron, metal curtain wall, rigging and reinforcing steel. Handling, sorting, and installation of reinforcing steel (rebar). Metal bridge rail (traffic), metal bridge handrail, and decorative security fence installation. Installation of aluminum window walls and curtain walls is the "joint" work of glaziers and ironworkers which require equal composite workforce.

- **INSULATOR**

- Installing fire stopping systems/materials for "Penetration Firestop Systems": transit to cables, electrical conduits, insulated pipes, sprinkler pipe penetrations, ductwork behind radiation, electrical cable trays, fire rated pipe penetrations, natural polypropylene, HVAC ducts, plumbing bare metal, telephone and communication wires, and boiler room ceilings.

- **LABORERS**

Acetylene burners, asphalt rakers, chain saw operators, concrete and power buggy operator, concrete saw operator, fence and guard rail erector (except metal bridge rail (traffic), decorative security fence (non-metal)).

installation.), hand operated concrete vibrator operator, mason tenders, pipelayers (installation of storm drainage or sewage lines on the street only), pneumatic drill operator, pneumatic gas and electric drill operator, powermen and wagon drill operator, air track operator, block paver, curb setters, blasters, concrete spreaders.

- **PAINTERS**

Maintenance, preparation, cleaning, blasting (water and sand, etc.), painting or application of any protective coatings of every description on all bridges and appurtenances of highways, roadways, and railroads. Painting, decorating, hardwood finishing, paper hanging, sign writing, scenic art work and drywall hhg for any and all types of building and residential work.

- **LEAD PAINT REMOVAL**

- Painter's Rate

1. Removal of lead paint from bridges.
2. Removal of lead paint as preparation of any surface to be repainted.
3. Where removal is on a Demolition project prior to reconstruction.

- Laborer's Rate

1. Removal of lead paint from any surface NOT to be repainted.
2. Where removal is on a *TOTAL* Demolition project only.

- **PLUMBERS AND PIPEFITTERS**

Installation, repair, replacement, alteration or maintenance of all plumbing, heating, cooling and piping. ***\*License required per Connecticut General Statutes: P-1,2,6,7,8,9 J-1,2,3,4 SP-1,2 S-1,2,3,4,5,6,7,8 B-1,2,3,4 D-1,2,3,4.***

- **POWER EQUIPMENT OPERATORS**

Operates several types of power construction equipment such as compressors, pumps, hoists, derricks, cranes, shovels, tractors, scrapers or motor graders, etc. Repairs and maintains equipment. ***\*License required, crane operators only, per Connecticut General Statutes.***

- **ROOFERS**

Covers roofs with composition shingles or sheets, wood shingles, slate or asphalt and gravel to waterproof roofs, including preparation of surface. (demolition or removal of any type of roofing and or clean-up of any and all areas where a roof is to be relaid.)

- **SHEETMETAL WORKERS**

Fabricate, assembles, installs and repairs sheetmetal products and equipment in such areas as ventilation, air-conditioning, warm air heating, restaurant equipment, architectural sheet metal work, sheetmetal roofing, and aluminum gutters. Fabrication, handling, assembling, erecting, altering, repairing, etc. of coated metal material panels and composite metal material panels when used on building exteriors and interiors as soffits, fascia, louvers, partitions, canopies, cornice, column covers, awnings, beam covers, cladding, sun shades, lighting troughs, spires, ornamental roofing, metal ceilings, mansards, copings, ornamental and ventilation hoods, vertical and horizontal siding panels, trim, etc. The sheet metal classification also applies to the vast variety of coated metal material panels and composite metal material panels that have evolved over the years as an alternative to conventional ferrous and non-ferrous metals like steel, iron, tin, copper, brass, bronze, aluminum, etc. Fabrication, handling, assembling, erecting, altering, repairing, etc. of architectural metal roof, standing seam roof, composite metal roof, metal and composite bathroom/toilet partitions, aluminum gutters, metal and composite lockers and shelving, kitchen equipment, and walk-in coolers. To include testing and air –balancing ancillary to installation and construction.

- **SPRINKLER FITTERS**

Installation, alteration, maintenance and repair of fire protection sprinkler systems.

***\*License required per Connecticut General Statutes: F-1,2,3,4.***

- **TILE MARBLE AND TERRAZZO FINISHERS**

Assists and tends the tile setter, marble mason and terrazzo worker in the performance of their duties.

- **TRUCK DRIVERS**

~How to pay truck drivers delivering asphalt is under REVISION~

Truck Drivers are requires to be paid prevailing wage for time spent "working" directly on the site. These drivers remain covered by the prevailing wage for any time spent transporting between the actual construction location and facilities (such as fabrication, plants, mobile factories, batch plant, borrow pits, job headquarters, tool yards, etc.) dedicated exclusively, or nearly so, to performance of the contract or project, which are so located in proximity to the actual construction location that it is reasonable to include them. ***\*License required, drivers only, per Connecticut General Statutes.***

***For example:***

- Material men and deliverymen are not covered under prevailing wage as long as they are not directly involved in the construction process. If, they unload the material, they would then be covered by prevailing wage for the classification they are performing work in: laborer, equipment operator, etc.
- Hauling material off site is not covered provided they are not dumping it at a location outlined above.
- Driving a truck on site and moving equipment or materials on site would be considered covered work, as this is part of the construction process.

➤ *Any questions regarding the proper classification should be directed to:*  
*Public Contract Compliance Unit*  
*Wage and Workplace Standards Division*  
*Connecticut Department of Labor*  
*200 Folly Brook Blvd, Wethersfield, CT 06109*  
*(860) 263-6543.*

**Minimum Rates and Classifications for  
Heavy/Highway Construction**

ID#: 20-12088

**Connecticut Department of Labor  
Wage and Workplace Standards Division**

By virtue of the authority vested in the Labor Commissioner under provisions of Section 31-53 of the General Statutes of Connecticut, as amended, the following are declared to be the prevailing rates and welfare payments and will apply only where the contract is advertised for bid within 20 days of the date on which the rates are established. Any contractor or subcontractor not obligated by agreement to pay to the welfare and pension fund shall pay this amount to each employee as part of his/her hourly wages.

Project Number: ECSU-2020-8

Project Town: Mansfield

State#: ECSU 2020-8

FAP#: ECSU

Project: Renovations to ECSU Athletic Fields

<b>CLASSIFICATION</b>	<b>Hourly Rate</b>	<b>Benefits</b>
1) Boilermaker	33.79	34% + 8.96
1a) Bricklayer, Cement Masons, Cement Finishers, Plasterers, Stone Masons	35.72	33.16
2) Carpenters, Piledrivermen	33.53	25.66
2a) Diver Tenders	33.53	25.66
3) Divers	41.99	25.66
03a) Millwrights	34.94	26.19
4) Painters: (Bridge Construction) Brush, Roller, Blasting (Sand, Water, etc.), Spray	51.0	21.80
4a) Painters: Brush and Roller	34.62	21.80
4b) Painters: Spray Only	36.62	21.80
4c) Painters: Steel Only	35.62	21.80
4d) Painters: Blast and Spray	37.62	21.80
4e) Painters: Tanks, Tower and Swing	36.62	21.80

Project: Renovations to ECSU Athletic Fields

5) Electrician (Trade License required: E-1,2 L-5,6 C-5,6 T-1,2 L-1,2 V-1,2,7,8,9)	40.0	27.67+3% of gross wage
6) Ironworkers: Ornamental, Reinforcing, Structural, and Precast Concrete Erection	36.67	35.77 + a
7) Plumbers (Trade License required: (P-1,2,6,7,8,9 J-1,2,3,4 SP-1,2) and Pipefitters (Including HVAC Work) (Trade License required: S-1,2,3,4,5,6,7,8 B-1,2,3,4 D-1,2,3,4 G-1, G-2, G-8, G-9)	43.62	32.06
----LABORERS-----		
8) Group 1: Laborer (Unskilled), Common or General, acetylene burner, concrete specialist	30.75	20.84
9) Group 2: Chain saw operators, fence and guard rail erectors, pneumatic tool operators, powdermen	31.0	20.84
10) Group 3: Pipelayers	31.25	20.84
11) Group 4: Jackhammer/Pavement breaker (handheld); mason tenders (cement/concrete), catch basin builders, asphalt rakers, air track operators, block paver, curb setter and forklift operators	31.25	20.84
12) Group 5: Toxic waste removal (non-mechanical systems)	32.75	20.84
13) Group 6: Blasters	32.5	20.84
Group 7: Asbestos/lead removal, non-mechanical systems (does not include leaded joint pipe)	31.75	20.84
Group 8: Traffic control signalmen	18.0	20.84
Group 9: Hydraulic Drills	29.3	18.90
----LABORERS (TUNNEL CONSTRUCTION, FREE AIR). Shield Drive and Liner Plate Tunnels in Free Air.----		
13a) Miners, Motormen, Mucking Machine Operators, Nozzle Men, Grout Men, Shaft & Tunnel Steel & Rodmen, Shield & Erector, Arm Operator, Cable Tenders	32.98	20.84 + a
13b) Brakemen, Trackmen	32.01	20.84 + a
----CLEANING, CONCRETE AND CAULKING TUNNEL----		

As of: April 16, 2020

Project: Renovations to ECSU Athletic Fields

14) Concrete Workers, Form Movers, and Strippers	32.01	20.84 + a
15) Form Erectors	32.34	20.84 + a
----ROCK SHAFT LINING, CONCRETE, LINING OF SAME AND TUNNEL IN FREE AIR:----		
16) Brakemen, Trackmen, Tunnel Laborers, Shaft Laborers	32.01	20.84 + a
17) Laborers Topside, Cage Tenders, Bellman	31.9	20.84 + a
18) Miners	32.98	20.84 + a
----TUNNELS, CAISSON AND CYLINDER WORK IN COMPRESSED AIR: ----		
18a) Blaster	39.47	20.84 + a
19) Brakemen, Trackmen, Groutman, Laborers, Outside Lock Tender, Gauge Tenders	39.27	20.84 + a
20) Change House Attendants, Powder Watchmen, Top on Iron Bolts	37.29	20.84 + a
21) Mucking Machine Operator	40.06	20.84 + a
----TRUCK DRIVERS----(*see note below)		
Two axle trucks	29.51	24.52 + a
Three axle trucks; two axle ready mix	29.62	24.52 + a
Three axle ready mix	29.67	24.52 + a
Four axle trucks, heavy duty trailer (up to 40 tons)	29.72	24.52 + a
Four axle ready-mix	29.77	24.52 + a
Heavy duty trailer (40 tons and over)	29.98	24.52 + a

As of: April 16, 2020

Project: Renovations to ECSU Athletic Fields

Specialized earth moving equipment other than conventional type on-the road trucks and semi-trailer (including Euclids)	29.77	24.52 + a
---	-------	-----------

---

----POWER EQUIPMENT OPERATORS----

---

Group 1: Crane handling or erecting structural steel or stone, hoisting engineer (2 drums or over), front end loader (7 cubic yards or over), Work Boat 26 ft. & Over, Tunnel Boring Machines. (Trade License Required)	40.97	24.80 + a
---	-------	-----------

Group 2: Cranes (100 ton rate capacity and over); Excavator over 2 cubic yards; Piledriver (\$3.00 premium when operator controls hammer); Bauer Drill/Caisson. (Trade License Required)	40.64	24.80 + a
--	-------	-----------

Group 3: Excavator/Backhoe under 2 cubic yards; Cranes (under 100 ton rated capacity), Gradall; Master Mechanic; Hoisting Engineer (all types of equipment where a drum and cable are used to hoist or drag material regardless of motive power of operation), Rubber Tire Excavator (Drott-1085 or similar); Grader Operator; Bulldozer Fine Grade (slopes, shaping, laser or GPS, etc.). (Trade License Required)	39.88	24.80 + a
---	-------	-----------

Group 4: Trenching Machines; Lighter Derrick; Concrete Finishing Machine; CMI Machine or Similar; Koehring Loader (Skooper)	39.48	24.80 + a
---	-------	-----------

Group 5: Specialty Railroad Equipment; Asphalt Paver; Asphalt Spreader; Asphalt Reclaiming Machine; Line Grinder; Concrete Pumps; Drills with Self Contained Power Units; Boring Machine; Post Hole Digger; Auger; Pounder; Well Digger; Milling Machine (over 24	38.87	24.80 + a
---	-------	-----------

Group 5 continued: Side Boom; Combination Hoe and Loader; Directional Driller.	38.87	24.80 + a
--	-------	-----------

Group 6: Front End Loader (3 up to 7 cubic yards); Bulldozer (rough grade dozer).	38.55	24.80 + a
---	-------	-----------

Group 7: Asphalt Roller; Concrete Saws and Cutters (ride on types); Vermeer Concrete Cutter; Stump Grinder; Scraper; Snooper; Skidder; Milling Machine (24	38.2	24.80 + a
--	------	-----------

Group 8: Mechanic, Grease Truck Operator, Hydroblaster, Barrier Mover, Power Stone Spreader; Welder; Work Boat under 26 ft.; Transfer Machine.	37.79	24.80 + a
--	-------	-----------

Group 9: Front End Loader (under 3 cubic yards), Skid Steer Loader regardless of attachments (Bobcat or Similar); Fork Lift, Power Chipper; Landscape Equipment (including hydroseeder).	37.34	24.80 + a
--	-------	-----------

Group 10: Vibratory Hammer, Ice Machine, Diesel and Air Hammer, etc.	35.24	24.80 + a
--	-------	-----------

Group 11: Conveyor, Earth Roller; Power Pavement Breaker (whiphammer), Robot Demolition Equipment.	35.24	24.80 + a
--	-------	-----------

Group 12: Wellpoint Operator.	35.18	24.80 + a
-------------------------------	-------	-----------

---

As of: April 16, 2020

Project: Renovations to ECSU Athletic Fields

Group 13: Compressor Battery Operator.	34.58	24.80 + a
Group 14: Elevator Operator; Tow Motor Operator (Solid Tire No Rough Terrain).	33.41	24.80 + a
Group 15: Generator Operator; Compressor Operator; Pump Operator; Welding Machine Operator; Heater Operator.	32.99	24.80 + a
Group 16: Maintenance Engineer/Oiler	32.32	24.80 + a
Group 17: Portable asphalt plant operator; portable crusher plant operator; portable concrete plant operator.	36.76	24.80 + a
Group 18: Power Safety Boat; Vacuum Truck; Zim Mixer; Sweeper; (minimum for any job requiring CDL license).	34.26	24.80 + a

**\*\*NOTE: SEE BELOW**

----LINE CONSTRUCTION----(Railroad Construction and Maintenance)---

20) Lineman, Cable Splicer, Technician	48.19	6.5% + 22.00
21) Heavy Equipment Operator	42.26	6.5% + 19.88
22) Equipment Operator, Tractor Trailer Driver, Material Men	40.96	6.5% + 19.21
23) Driver Groundmen	26.5	6.5% + 9.00
23a) Truck Driver	40.96	6.5% + 17.76
----LINE CONSTRUCTION----		
24) Driver Groundmen	30.92	6.5% + 9.70
25) Groundmen	22.67	6.5% + 6.20
26) Heavy Equipment Operators	37.1	6.5% + 10.70
27) Linemen, Cable Splicers, Dynamite Men	41.22	6.5% + 12.20

**As of:** April 16, 2020

Project: Renovations to ECSU Athletic Fields

28) Material Men, Tractor Trailer Drivers, Equipment Operators

35.04

6.5% + 10.45

---

Project: Renovations to ECSU Athletic Fields

Welders: Rate for craft to which welding is incidental.

\*Note: Hazardous waste removal work receives additional \$1.25 per hour for truck drivers.

\*\*Note: Hazardous waste premium \$3.00 per hour over classified rate

**ALL Cranes: When crane operator is operating equipment that requires a fully licensed crane operator to operate he receives an extra \$4.00 premium in addition to the hourly wage rate and benefit contributions:**

- 1) Crane handling or erecting structural steel or stone; hoisting engineer (2 drums or over)**
- 2) Cranes (100 ton rate capacity and over) Bauer Drill/Caisson**
- 3) Cranes (under 100 ton rated capacity)**

Crane with 150 ft. boom (including jib) - \$1.50 extra

Crane with 200 ft. boom (including jib) - \$2.50 extra

Crane with 250 ft. boom (including jib) - \$5.00 extra

Crane with 300 ft. boom (including jib) - \$7.00 extra

Crane with 400 ft. boom (including jib) - \$10.00 extra

All classifications that indicate a percentage of the fringe benefits must be calculated at the percentage rate times the "base hourly rate".

Apprentices duly registered under the Commissioner of Labor's regulations on "Work Training Standards for Apprenticeship and Training Programs" Section 31-51-d-1 to 12, are allowed to be paid the appropriate percentage of the prevailing journeymen hourly base and the full fringe benefit rate, providing the work site ratio shall not be less than one full-time journeyman instructing and supervising the work of each apprentice in a specific trade.

--Connecticut General Statute Section 31-55a: Annual Adjustments to wage rates by contractors doing

*The Prevailing wage rates applicable to this project are subject to annual adjustments each July 1st for the duration of the project.*

*Each contractor shall pay the annual adjusted prevailing wage rate that is in effect each July 1st, as posted by the Department of Labor.*

*It is the contractor's responsibility to obtain the annual adjusted prevailing wage rate increases directly from the Department of Labor's website.*

*The annual adjustments will be posted on the Department of Labor's Web page: [www.ct.gov/dol](http://www.ct.gov/dol). For those without internet access, please contact the division listed below.*

*The Department of Labor will continue to issue the initial prevailing wage rate schedule to the Contracting Agency for the project.*

*All subsequent annual adjustments will be posted on our Web Site for contractor access.*

*Contracting Agencies are under no obligation pursuant to State labor law to pay any increase due to the annual adjustment provision.*

*Effective October 1, 2005 - Public Act 05-50: any person performing the work of any mechanic, laborer, or worker shall be paid prevailing wage*

All Person who perform work ON SITE must be paid prevailing wage for the appropriate mechanic, laborer, or worker classification.

All certified payrolls must list the hours worked and wages paid to All Persons who perform work ON SITE regardless of their ownership i.e.: (Owners, Corporate Officers, LLC Members, Independent Contractors, et. al)

Reporting and payment of wages is required regardless of any contractual relationship alleged to exist between the contractor and such person.

**As of:** April 16, 2020

Project: Renovations to ECSU Athletic Fields

**~~Unlisted classifications needed for work not included within the scope of the classifications listed may be added after award only as provided in the labor standards contract clause (29 CFR 5.5 (a) (1) (ii)).**

Please direct any questions which you may have pertaining to classification of work and payment of prevailing wages to the Wage and Workplace Standards Division, telephone (860)263-6790.

**As of:** April 16, 2020

November 29, 2006

**Notice**  
**To All Mason Contractors and Interested Parties**  
**Regarding Construction Pursuant to Section 31-53 of the**  
**Connecticut General Statutes (Prevailing Wage)**

The Connecticut Labor Department Wage and Workplace Standards Division is empowered to enforce the prevailing wage rates on projects covered by the above referenced statute.

Over the past few years the Division has withheld enforcement of the rate in effect for workers who operate a forklift on a prevailing wage rate project due to a potential jurisdictional dispute.

The rate listed in the schedules and in our Occupational Bulletin (see enclosed) has been as follows:

**Forklift Operator:**

- **Laborers (Group 4) Mason Tenders** - operates forklift solely to assist a mason to a maximum height of nine feet only.
- **Power Equipment Operator (Group 9)** - operates forklift to assist any trade and to assist a mason to a height over nine feet.

The U.S. Labor Department conducted a survey of rates in Connecticut but it has not been published and the rate in effect remains as outlined in the above Occupational Bulletin.

*Since this is a classification matter and not one of jurisdiction, effective January 1, 2007 the Connecticut Labor Department will enforce the rate on each schedule in accordance with our statutory authority.*

Your cooperation in filing appropriate and accurate certified payrolls is appreciated.

## STATUTE 31-55a

### - SPECIAL NOTICE -

**To: All State and Political Subdivisions, Their Agents, and Contractors**

**Connecticut General Statute 31-55a - Annual adjustments to wage rates by contractors doing state work.**

*Each contractor that is awarded a contract on or after October 1, 2002, for (1) the construction of a state highway or bridge that falls under the provisions of section 31-54 of the general statutes, or (2) the construction, remodeling, refinishing, refurbishing, rehabilitation, alteration or repair of any public works project that falls under the provisions of section 31-53 of the general statutes shall contact the Labor Commissioner on or before July first of each year, for the duration of such contract, to ascertain the prevailing rate of wages on an hourly basis and the amount of payment or contributions paid or payable on behalf of each mechanic, laborer or worker employed upon the work contracted to be done, and shall make any necessary adjustments to such prevailing rate of wages and such payment or contributions paid or payable on behalf of each such employee, effective each July first.*

- The prevailing wage rates applicable to any contract or subcontract awarded on or after October 1, 2002 are subject to annual adjustments each July 1st for the duration of any project which was originally advertised for bids on or after October 1, 2002.
- Each contractor affected by the above requirement shall pay the annual adjusted prevailing wage rate that is in effect each July 1st, as posted by the Department of Labor.
- It is the **contractor's** responsibility to obtain the annual adjusted prevailing wage rate increases directly from the Department of Labor's Web Site. The annual adjustments will be posted on the Department of Labor Web page: [www.ctdol.state.ct.us](http://www.ctdol.state.ct.us). For those without internet access, please contact the division listed below.
- The Department of Labor will continue to issue the initial prevailing wage rate schedule to the Contracting Agency for the project. All subsequent annual adjustments will be posted on our Web Site for contractor access.

**Any questions should be directed to the Contract Compliance Unit, Wage and Workplace Standards Division, Connecticut Department of Labor, 200 Folly Brook Blvd., Wethersfield, CT 06109 at (860)263-6790.**

**Connecticut Department of Labor  
Wage and Workplace Standards Division  
FOOTNOTES**

⇒ Please Note: If the “Benefits” listed on the schedule for the following occupations includes a letter(s) (+ a or + a+b for instance), refer to the information below.

Benefits to be paid at the appropriate prevailing wage rate for the listed occupation.

If the “Benefits” section for the occupation lists only a dollar amount, disregard the information below.

**Bricklayers, Cement Masons, Cement Finishers, Concrete Finishers, Stone Masons**  
(Building Construction) and  
(Residential- Hartford, Middlesex, New Haven, New London and Tolland Counties)

- a. Paid Holiday: Employees shall receive 4 hours for Christmas Eve holiday provided the employee works the regularly scheduled day before and after the holiday. Employers may schedule work on Christmas Eve and employees shall receive pay for actual hours worked in addition to holiday pay.

**Elevator Constructors: Mechanics**

- a. Paid Holidays: New Year’s Day, Memorial Day, Independence Day, Labor Day, Veterans’ Day, Thanksgiving Day, Christmas Day, plus the Friday after Thanksgiving.
- b. Vacation: Employer contributes 8% of basic hourly rate for 5 years or more of service or 6% of basic hourly rate for 6 months to 5 years of service as vacation pay credit.

**Glaziers**

- a. Paid Holidays: Labor Day and Christmas Day.

**Power Equipment Operators**  
(Heavy and Highway Construction & Building Construction)

- a. Paid Holidays: New Year’s Day, Good Friday, Memorial day, Independence Day, Labor Day, Thanksgiving Day and Christmas Day, provided the employee works 3 days during the week in which the holiday falls, if scheduled, and if scheduled, the working day before and the working day after the holiday. Holidays falling on Saturday may be observed on Saturday, or if the employer so elects, on the preceding Friday.

### **Ironworkers**

- a. Paid Holiday: Labor Day provided employee has been on the payroll for the 5 consecutive work days prior to Labor Day.

### **Laborers (Tunnel Construction)**

- a. Paid Holidays: New Year's Day, Memorial Day, Independence Day, Labor Day, Thanksgiving Day and Christmas Day. No employee shall be eligible for holiday pay when he fails, without cause, to work the regular work day preceding the holiday or the regular work day following the holiday.

### **Roofers**

- a. Paid Holidays: July 4<sup>th</sup>, Labor Day, and Christmas Day provided the employee is employed 15 days prior to the holiday.

### **Sprinkler Fitters**

- a. Paid Holidays: Memorial Day, July 4th, Labor Day, Thanksgiving Day and Christmas Day, provided the employee has been in the employment of a contractor 20 working days prior to any such paid holiday.

### **Truck Drivers**

(Heavy and Highway Construction & Building Construction)

- a. Paid Holidays: New Year's Day, Memorial Day, Independence Day, Labor Day, Thanksgiving Day, Christmas day, and Good Friday, provided the employee has at least 31 calendar days of service and works the last scheduled day before and the first scheduled day after the holiday, unless excused.

**Sec. 31-53b. Construction safety and health course. New miner training program. Proof of completion required for mechanics, laborers and workers on public works projects. Enforcement. Regulations. Exceptions.** (a) Each contract for a public works project entered into on or after July 1, 2009, by the state or any of its agents, or by any political subdivision of the state or any of its agents, described in subsection (g) of section 31-53, shall contain a provision requiring that each contractor furnish proof with the weekly certified payroll form for the first week each employee begins work on such project that any person performing the work of a mechanic, laborer or worker pursuant to the classifications of labor under section 31-53 on such public works project, pursuant to such contract, has completed a course of at least ten hours in duration in construction safety and health approved by the federal Occupational Safety and Health Administration or, has completed a new miner training program approved by the Federal Mine Safety and Health Administration in accordance with 30 CFR 48 or, in the case of telecommunications employees, has completed at least ten hours of training in accordance with 29 CFR 1910.268.

(b) Any person required to complete a course or program under subsection (a) of this section who has not completed the course or program shall be subject to removal from the worksite if the person does not provide documentation of having completed such course or program by the fifteenth day after the date the person is found to be in noncompliance. The Labor Commissioner or said commissioner's designee shall enforce this section.

(c) Not later than January 1, 2009, the Labor Commissioner shall adopt regulations, in accordance with the provisions of chapter 54, to implement the provisions of subsections (a) and (b) of this section. Such regulations shall require that the ten-hour construction safety and health courses required under subsection (a) of this section be conducted in accordance with federal Occupational Safety and Health Administration Training Institute standards, or in accordance with Federal Mine Safety and Health Administration Standards or in accordance with 29 CFR 1910.268, as appropriate. The Labor Commissioner shall accept as sufficient proof of compliance with the provisions of subsection (a) or (b) of this section a student course completion card issued by the federal Occupational Safety and Health Administration Training Institute, or such other proof of compliance said commissioner deems appropriate, dated no earlier than five years before the commencement date of such public works project.

(d) This section shall not apply to employees of public service companies, as defined in section 16-1, or drivers of commercial motor vehicles driving the vehicle on the public works project and delivering or picking up cargo from public works projects provided they perform no labor relating to the project other than the loading and unloading of their cargo.

(P.A. 06-175, S. 1; P.A. 08-83, S. 1.)

History: P.A. 08-83 amended Subsec. (a) by making provisions applicable to public works project contracts entered into on or after July 1, 2009, replacing provision re total cost of work with reference to Sec. 31-53(g), requiring proof in certified payroll form that new mechanic, laborer or worker has completed a 10-hour or more construction safety course and adding provision re new miner training program, amended Subsec. (b) by substituting "person" for "employee" and adding "or program", amended Subsec. (c) by adding "or in accordance with Federal Mine Safety and Health Administration Standards" and setting new deadline of January 1, 2009, deleted former Subsec. (d) re "public building", added new Subsec. (d) re exemptions for public service company employees and delivery drivers who perform no labor other than delivery and made conforming and technical changes, effective January 1, 2009.

# **Informational Bulletin**

## **THE 10-HOUR OSHA CONSTRUCTION SAFETY AND HEALTH COURSE**

(applicable to public building contracts entered into *on or after July 1, 2007*, where the total cost of all work to be performed is at least \$100,000)

- (1) This requirement was created by Public Act No. 06-175, which is codified in Section 31-53b of the Connecticut General Statutes (pertaining to the prevailing wage statutes);
- (2) The course is required for public building construction contracts (projects funded in whole or in part by the state or any political subdivision of the state) entered into on or after July 1, 2007;
- (3) It is required of private employees (not state or municipal employees) and apprentices who perform manual labor for a general contractor or subcontractor on a public building project where the total cost of all work to be performed is at least \$100,000;
- (4) The ten-hour construction course pertains to the ten-hour Outreach Course conducted in accordance with federal OSHA Training Institute standards, and, for telecommunications workers, a ten-hour training course conducted in accordance with federal OSHA standard, 29 CFR 1910.268;
- (5) The internet website for the federal OSHA Training Institute is [http://www.osha.gov/fso/ote/training/edcenters/fact\\_sheet.html](http://www.osha.gov/fso/ote/training/edcenters/fact_sheet.html);
- (6) The statutory language leaves it to the contractor and its employees to determine who pays for the cost of the ten-hour Outreach Course;
- (7) Within 30 days of receiving a contract award, a general contractor must furnish proof to the Labor Commissioner that all employees and apprentices performing manual labor on the project will have completed such a course;
- (8) Proof of completion may be demonstrated through either: (a) the presentation of a *bona fide* student course completion card issued by the federal OSHA Training Institute; *or* (2) the presentation of documentation provided to an employee by a trainer certified by the Institute pending the actual issuance of the completion card;
- (9) Any card with an issuance date more than 5 years prior to the commencement date of the construction project shall not constitute proof of compliance;

- (10) Each employer shall affix a copy of the construction safety course completion card to the certified payroll submitted to the contracting agency in accordance with Conn. Gen. Stat. § 31-53(f) on which such employee's name first appears;
- (11) Any employee found to be in non-compliance shall be subject to removal from the worksite if such employee does not provide satisfactory proof of course completion to the Labor Commissioner by the fifteenth day after the date the employee is determined to be in noncompliance;
- (12) Any such employee who is determined to be in noncompliance may continue to work on a public building construction project for a maximum of fourteen consecutive calendar days while bringing his or her status into compliance;
- (13) The Labor Commissioner may make complaint to the prosecuting authorities regarding any employer or agent of the employer, or officer or agent of the corporation who files a false certified payroll with respect to the status of an employee who is performing manual labor on a public building construction project;
- (14) The statute provides the minimum standards required for the completion of a safety course by manual laborers on public construction contracts; any contractor can exceed these minimum requirements; and
- (15) Regulations clarifying the statute are currently in the regulatory process, and shall be posted on the CTDOL website as soon as they are adopted in final form.
- (16) Any questions regarding this statute may be directed to the Wage and Workplace Standards Division of the Connecticut Labor Department via the internet website of <http://www.ctdol.state.ct.us/wgwkstnd/wgemenu.htm>; or by telephone at (860)263-6790.

**THE ABOVE INFORMATION IS PROVIDED EXCLUSIVELY AS AN EDUCATIONAL RESOURCE, AND IS NOT INTENDED AS A SUBSTITUTE FOR LEGAL INTERPRETATIONS WHICH MAY ULTIMATELY ARISE CONCERNING THE CONSTRUCTION OF THE STATUTE OR THE REGULATIONS.**

STATE OF CONNECTICUT  
**CERTIFICATE OF INSURANCE**

This is to certify that the Company listed below has issued the policies listed below, that these policies are written in accordance with the Company's standard policies and endorsements, except as indicated below or as noted in the attachments hereto, which policies and endorsements will be made available to the Owner upon request, that they provide coverage and limits of liability shown with respect to the insurance indicated, that they are in force on this date, that all deductible amounts are indicated below, and that this Certificate is furnished in accordance with and for the purpose of satisfying the requirements of the State of Connecticut, and the Agency in connection with the award and performance of a contract or agreement with the State of Connecticut, and the Agency.

1. Name of insured \_\_\_\_\_

2. Address of insured \_\_\_\_\_

3. Location and Description of Work \_\_\_\_\_

\_\_\_\_\_

Project No. \_\_\_\_\_

Kind and Type of Insurance	Policy No.	Effective Date	Expiration Date	IN DOLLARS Coverage and limits of Liability		
				Bodily Injury Liability		Property Damage Liability
				Single Limit	Each Accident	Aggregate
A) Protective Liability for and in the name of the State of CT See (1) Reverse Side				1,000,000	100,000	500,000
B) Contractor's Liability				1,000,000	100,000	500,000
C) Contractor Protective Liability				1,000,000	100,000	500,000
D) Contractual Liability See (1) & (2) Reverse Side				1,000,000	100,000	500,000
E) Worker's Compensation (if self-insured Compensation Comm's Certificate Required.				STATUTORY		
F) Special Hazards Insurance Type C- Collapse Structural Injury Type X- explosion or Blast				1,000,000	100,000	500,000
G) Type U-underground Damage				1,000,000	100,000	500,000
H) Auto Liability Owned Automobiles Hired Automobiles Non-owned Automobiles				Each Person	Each Accident	
I) Builders Risk insurance (Fire Extended Coverage)				AS CALLED FOR ON PROJECT DATA SHEET		
J) Umbrella Policy ( as needed )						

1. Unless requested otherwise by the State, it is agreed that the above named insurance company waives governmental immunity as a defense and will not use the defense of governmental immunity in the adjustment of claims or in the defense of any suit brought against the State, and it is further agreed that the company will bill all premiums and audit charges earned under the protective liability policy to the above named contractor.
  
2. The contractor shall at all times indemnify and save harmless the State of Connecticut, the Agency, and their respective officers, agents, and employees, on account of any and all claims, damages, losses, litigation, expenses, counsel fees, and compensation arising out of injuries (including death) sustained by or alleged to have been sustained by the officers, agents, and employees of said State or Agency, or of the contractor, his subcontractors, or material men, and from injuries (including death) sustained by or alleged to have been sustained by the public, any or all persons on or near the work, or by any other person or property, real or personal (including property of said State or Agency) caused in whole or in part by the acts, omissions, or neglect of the contractor including but not limited to any neglect in safeguarding the work or through the use of unacceptable materials in constructing the work of the contractor, any subcontractor, material man, or anyone directly employed by them or any of them while engaged in the performance of the contract, including the entire elapsed time from the date ordered to start work or the actual start whichever occurs first until the completion as certified by the Owner.

Such insurance as is herein certified applies to all operations of the insured in connection with the work herein described at the locations stated.

In the event of any restrictive amendment to, any change in or cancellation of any one or more of said policies the

---

Insurance Company

will give not less than thirty days written notice to the party to whom the certificate is issued of such amendment, change or cancellation.

(Original and two copies to be submitted to the awarding Agency in the State of Connecticut. Copy to be furnished named insurance.)

Dated this \_\_\_\_\_ day of \_\_\_\_\_ 2020

Insurance Company \_\_\_\_\_

Address \_\_\_\_\_

Authorized Agency \_\_\_\_\_

Authorized Agent \_\_\_\_\_

# AGREEMENT

BETWEEN  
**Eastern Connecticut State University**  
AND  
**Contractor by Name**

This Agreement (“Contract”) is entered into by and between [Eastern Connecticut State University], a constituent unit of the State of Connecticut System of Higher Education, with an address of 83 Windham Street, Willimantic, CT 06226 (hereinafter the “Institution”), and [Name of Company] (hereinafter the “Contractor”) with a principal place of business at \_\_\_\_\_ to provide [name the service].

## I. GENERAL

Contractor shall provide [describe the service to be provided]

## II. TERM OF THE AGREEMENT

This Contract shall become effective only as of the date of signature by the Agency’s authorized officials and, the date of approval by the Office of the Attorney General (OAG), if applicable, and shall continue in effect until [insert end date] unless terminated earlier in accordance with the terms of Section 7 below. Work shall commence on [insert start date].

## III. COST [insert RFP/Bid costing details]

1. **MAXIMUM AMOUNT OF CONTRACT \$** [insert not to exceed amount]
2. **Notices:** All notices, demands or requests provided for or permitted to be given pursuant to this Contract must be in writing. All notices, demands and requests shall be deemed to have been properly served if given by personal delivery, or if transmitted by facsimile with confirmed receipt, or if delivered to Federal Express or other reputable express carrier for next business day delivery, charges billed to or prepaid by shipper; or if deposited in the United States mail, registered or certified with return receipt requested, proper postage prepaid, addressed as follows:

### MUST BE COMPLETED

If to the Eastern Connecticut State University  
Institution\*: 83 Windham Street  
Willimantic, CT 06226  
Attn: Renee Theroux-Keech

If to the **[Contractor Name]**  
Contractor\*: **[Contractor Street]**

**\*Any party may change its Notice information in writing in accordance with this Section.**

#### **IV. GENERAL STATE CONTRACT PROVISIONS:**

1. **Statutory Authority.** Connecticut General Statutes §§ 10a-6, 10a-1b, 4a-52a, and/or 10a-151b provide the Institution with authority to enter into contracts in the pursuit of its mission.
2. **Claims Against the State.** The Contractor agrees that the sole and exclusive means for the presentation of any claim against the State of Connecticut or the Institution arising from this Contract shall be in accordance with Chapter 53 of the Connecticut General Statutes (Claims Against the State) and the Contractor further agrees not to initiate any legal proceedings in any state or federal court in addition to, or in lieu of, said Chapter 53 proceedings.
3. **Indemnification.** The Contractor agrees to indemnify, defend and hold harmless the State of Connecticut as well as all Departments, officers, agents, and employees of the State from and against any and all claims, losses or suits according to or resulting from any Contractors, Subcontractors, laborers, or any person, firm or corporation who may be directly or indirectly injured or damaged by the negligence or willful misconduct of the Contractor in the performance of the contract.
4. **Sovereign Immunity.** The parties acknowledge and agree that nothing in this contract shall be construed as a modification, compromise or waiver by the State of any rights or defenses of any immunities provided by Federal law or the laws of the State of Connecticut to the State or any of its officers and employees, which they may have had, now have or will have with respect to all matters arising out of this contract. To the extent that this section conflicts with any other section, this section shall govern.
5. **Insurance.** The Contractor agrees that while performing services specified in this contract that it shall carry sufficient insurance (liability and/or other) as applicable according to the nature of the service(s) to be performed so as to “save harmless” the State of Connecticut from any insurable cause whatsoever. If requested, certificates of such insurance shall be provided to the contracting state agency prior to the performance of services.
6. **Forum and Choice of Law.** The parties deem the Contract to have been made in the City of Hartford, State of Connecticut. Both parties agree that it is fair and reasonable for the validity and construction of the contract to be, and it shall be, governed by the laws and court decisions of the State of Connecticut, without giving effect to its principles of conflicts of laws. To the extent that any immunities provided by Federal law or the laws of the State of Connecticut do not bar an action against the State, and to the extent that these courts are courts of competent jurisdiction, for the purpose of venue, the complaint shall be made returnable to the Judicial District of Hartford only or shall be brought in the United States District Court for the District of Connecticut only, and shall not be transferred to any other court, provided, however, that nothing here constitutes a waiver or compromise of the sovereign immunity of the State of Connecticut. The Contractor waives any objection which it may now have or will have to the laying of venue of any claims in any forum and further irrevocably submits to such jurisdiction in any suit, action or proceeding.
7. **Termination.**

- a. Notwithstanding any provisions in this contract, the Institution, through a duly authorized employee, may terminate the Contract whenever the Institution makes a written determination that such termination is in the best interests of the State. The Institution shall notify the Contractor in writing of termination pursuant to this section, which notice shall specify the effective date of termination and the extent to which the Contractor must complete its performance under the contract prior to such date.
- b. Notwithstanding any provisions in this contract, the Institution, through a duly authorized employee, may, after making a written determination that the Contractor has breached the contract, terminate the contract in accordance with the following breach provision.
  - i. Breach. If either party breaches the contract in any respect, the non-breaching party shall provide written notice of the breach to the breaching party and afford the breaching party an opportunity to cure within ten (10) days from the date that the breaching party receives the notice. In the case of a Contractor breach, any other time period which the Institution sets forth in the notice shall trump the ten (10) days. The right to cure period shall be extended if the non-breaching party is satisfied that the breaching party is making a good faith effort to cure but the nature of the breach is such that it cannot be cured within the right to cure period. The notice may include an effective contract termination date if the breach is not cured by the stated date and, unless otherwise modified by the non-breaching party in writing prior to the termination date, no further action shall be required of any party to effect the termination as of the stated date. If the notice does not set forth an effective contract termination date, then the non-breaching party may terminate the contract by giving the breaching party no less than twenty four (24) hours' prior written notice. If the Institution believes that the Contractor has not performed according to the contract, the Institution may withhold payment in whole or in part pending resolution of the performance issue, provided that the Institution notifies the Contractor in writing prior to the date that the payment would have been due.
- c. The Institution shall send the notice of termination via certified mail, return receipt requested, to the Contractor at the most current address which the Contractor has furnished to the Institution for purposes of correspondence, or by hand delivery. Upon receiving the notice from the Institution, the Contractor shall immediately discontinue all services affected in accordance with the notice, undertake all Institution all records. The records are deemed to be the property of the Institution and the Contractor shall deliver them to the Institution no later than thirty (30) days after the termination of the contract or fifteen (15) days after the Contractor receives a written request from the Institution for the records. The Contractor shall deliver those records that exist in electronic, magnetic or other intangible form in a non-proprietary format, such as, but not limited to, ASCII or .TXT.
- d. Upon receipt of a written notice of termination from the Institution, the Contractor shall cease operations as the Institution directs in the notice, and take

all actions that are necessary or appropriate, or that the Institution may reasonably direct, for the protection, and preservation of the goods and any other property. Except for any work which the Institution directs the Contractor to perform in the notice prior to the effective date of termination, and except as otherwise provided in the notice, the Contractor shall terminate or conclude all existing subcontracts and purchase orders and shall not enter into any further subcontracts, purchase orders or commitments.

- e. The Institution shall, within forty-five (45) days of the effective date of termination; reimburse the Contractor for its performance rendered and accepted by the Institution in accordance with the terms of this contract, in addition to all actual and reasonable costs incurred after termination in completing those portions of the performance which the notice required the Contractor to complete. However, the Contractor is not entitled to receive and the Institution is not obligated to tender to the Contractor any payments for anticipated or lost profits. Upon request by the Institution, the Contractor shall assign to the Institution, or any replacement Contractor which the Institution designates, all subcontracts, purchase orders and other commitments, deliver to the Institution all records and other information pertaining to its performance, and remove from State premises, whether leased or owned, all of Contractor's property, equipment, waste material and rubbish related to its performance, all as the Institution may request.
- f. For breach or violation of any of the provisions in the section concerning representations and warranties, the Institution may terminate the contract in accordance with its terms and revoke any consents to assignments given as if the assignments had never been requested or consented to, without liability to the Contractor or Contractor parties or any third party.
- g. Upon termination of the contract, all rights and obligations shall be null and void, so that no party shall have any further rights or obligations to any other party, except with respect to the sections which survive termination. All representations, warranties, agreements and rights of the parties under the contract shall survive such termination to the extent not otherwise limited in the contract and without each one of them having to be specifically mentioned in the contract.
- h. Termination of the contract pursuant to this section shall not be deemed to be a breach of contract by the Institution.

8. **Entire Agreement and Amendment.** This written contract shall constitute the entire agreement between the parties and no other terms and conditions in any document, acceptance or acknowledgment shall be effective or binding unless expressly agreed to in writing by the Institution. This contract may not be changed other than by a formal written contract amendment signed by the parties hereto and approved by the Connecticut Attorney General.

9. **Nondiscrimination.**

- (a) For purposes of this Section, the following terms are defined as follows: (i) "Commission" means the Commission on Human Rights and Opportunities; (ii)

"Contract" and "contract" include any extension or modification of the Contract or contract; (iii) "Contractor" and "contractor" include any successors or assigns of the Contractor or contractor; (iv) "Gender identity or expression" means a person's gender-related identity, appearance or behavior, whether or not that gender-related identity, appearance or behavior is different from that traditionally associated with the person's physiology or assigned sex at birth, which gender-related identity can be shown by providing evidence including, but not limited to, medical history, care or treatment of the gender-related identity, consistent and uniform assertion of the gender-related identity or any other evidence that the gender-related identity is sincerely held, part of a person's core identity or not being asserted for an improper purpose; (v) "good faith" means that degree of diligence which a reasonable person would exercise in the performance of legal duties and obligations; (vi) "good faith efforts" shall include, but not be limited to, those reasonable initial efforts necessary to comply with statutory or regulatory requirements and additional or substituted efforts when it is determined that such initial efforts will not be sufficient to comply with such requirements; (vii) "marital status" means being single, married as recognized by the State of Connecticut, widowed, separated or divorced; (viii) "mental disability" means one or more mental disorders, as defined in the most recent edition of the American Psychiatric Association's "Diagnostic and Statistical Manual of Mental Disorders", or a record of or regarding a person as having one or more such disorders; (ix) "minority business enterprise" means any small contractor or supplier of materials fifty-one percent or more of the capital stock, if any, or assets of which is owned by a person or persons: (1) who are active in the daily affairs of the enterprise, (2) who have the power to direct the management and policies of the enterprise, and (3) who are members of a minority, as such term is defined in subsection (a) of Connecticut General Statutes § 32-9n; and (x) "public works contract" means any agreement between any individual, firm or corporation and the State or any political subdivision of the State other than a municipality for construction, rehabilitation, conversion, extension, demolition or repair of a public building, highway or other changes or improvements in real property, or which is financed in whole or in part by the State, including, but not limited to, matching expenditures, grants, loans, insurance or guarantees.

For purposes of this Section, the terms "Contract" and "contract" do not include a contract where each contractor is (1) a political subdivision of the state, including, but not limited to, a municipality, (2) a quasi-public agency, as defined in Conn. Gen. Stat. § 1-120, (3) any other state, including but not limited to any federally recognized Indian tribal governments, as defined in Conn. Gen. Stat. § 1-267, (4) the federal government, (5) a foreign government, or (6) an agency of a subdivision, agency, state or government described in the immediately preceding enumerated items (1), (2), (3), (4) or (5).

(b) (1) The Contractor agrees and warrants that in the performance of the Contract such Contractor will not discriminate or permit discrimination against any person or group of persons on the grounds of race, color, religious creed, age, marital status, national origin, ancestry, sex, gender identity or expression, intellectual disability, mental disability or physical disability, including, but not limited to, blindness, unless it is shown by such Contractor that such disability prevents performance of the work involved, in any manner prohibited by the laws of the United States or of the State of Connecticut; and the Contractor further agrees to take affirmative action to insure that applicants with job-related qualifications are employed and that employees are treated when employed without regard to their race, color, religious creed, age, marital status, national origin,

ancestry, sex, gender identity or expression, intellectual disability, mental disability or physical disability, including, but not limited to, blindness, unless it is shown by the Contractor that such disability prevents performance of the work involved; (2) the Contractor agrees, in all solicitations or advertisements for employees placed by or on behalf of the Contractor, to state that it is an "affirmative action equal opportunity employer" in accordance with regulations adopted by the Commission; (3) the Contractor agrees to provide each labor union or representative of workers with which the Contractor has a collective bargaining Agreement or other contract or understanding and each vendor with which the Contractor has a contract or understanding, a notice to be provided by the Commission, advising the labor union or workers' representative of the Contractor's commitments under this section and to post copies of the notice in conspicuous places available to employees and applicants for employment; (4) the Contractor agrees to comply with each provision of this Section and Conn. Gen. Stat. §§ 46a-68e and 46a-68f and with each regulation or relevant order issued by said Commission pursuant to Conn. Gen. Stat. §§ 46a-56, 46a-68e and 46a-68f; and (5) the Contractor agrees to provide the Commission on Human Rights and Opportunities with such information requested by the Commission, and permit access to pertinent books, records and accounts, concerning the employment practices and procedures of the Contractor as it relates to the provisions of this Section and Conn. Gen. Stat. § 46a-56. If the contract is a public works contract, the Contractor agrees and warrants that he will make good faith efforts to employ minority business enterprises as subcontractors and suppliers of materials on such public works projects.

(c) Determination of the Contractor's good faith efforts shall include, but shall not be limited to, the following factors: The Contractor's employment and subcontracting policies, patterns and practices; affirmative advertising, recruitment and training; technical assistance activities and such other reasonable activities or efforts as the Commission may prescribe that are designed to ensure the participation of minority business enterprises in public works projects.

(d) The Contractor shall develop and maintain adequate documentation, in a manner prescribed by the Commission, of its good faith efforts.

(e) The Contractor shall include the provisions of subsection (b) of this Section in every subcontract or purchase order entered into in order to fulfill any obligation of a contract with the State and such provisions shall be binding on a subcontractor, vendor or manufacturer unless exempted by regulations or orders of the Commission. The Contractor shall take such action with respect to any such subcontract or purchase order as the Commission may direct as a means of enforcing such provisions including sanctions for noncompliance in accordance with Conn. Gen. Stat. § 46a-56; provided if such Contractor becomes involved in, or is threatened with, litigation with a subcontractor or vendor as a result of such direction by the Commission, the Contractor may request the State of Connecticut to enter into any such litigation or negotiation prior thereto to protect the interests of the State and the State may so enter.

(f) The Contractor agrees to comply with the regulations referred to in this Section as they exist on the date of this Contract and as they may be adopted or amended from time to time during the term of this Contract and any amendments thereto.

(g) (1) The Contractor agrees and warrants that in the performance of the Contract such Contractor will not discriminate or permit discrimination against any person or group of

persons on the grounds of sexual orientation, in any manner prohibited by the laws of the United States or the State of Connecticut, and that employees are treated when employed without regard to their sexual orientation; (2) the Contractor agrees to provide each labor union or representative of workers with which such Contractor has a collective bargaining Agreement or other contract or understanding and each vendor with which such Contractor has a contract or understanding, a notice to be provided by the Commission on Human Rights and Opportunities advising the labor union or workers' representative of the Contractor's commitments under this section, and to post copies of the notice in conspicuous places available to employees and applicants for employment; (3) the Contractor agrees to comply with each provision of this section and with each regulation or relevant order issued by said Commission pursuant to Conn. Gen. Stat. § 46a-56; and (4) the Contractor agrees to provide the Commission on Human Rights and Opportunities with such information requested by the Commission, and permit access to pertinent books, records and accounts, concerning the employment practices and procedures of the Contractor which relate to the provisions of this Section and Conn. Gen. Stat. § 46a-56.

(h) The Contractor shall include the provisions of the foregoing paragraph in every subcontract or purchase order entered into in order to fulfill any obligation of a contract with the State and such provisions shall be binding on a subcontractor, vendor or manufacturer unless exempted by regulations or orders of the Commission. The Contractor shall take such action with respect to any such subcontract or purchase order as the Commission may direct as a means of enforcing such provisions including sanctions for noncompliance in accordance with Conn. Gen. Stat. § 46a-56; provided, if such Contractor becomes involved in, or is threatened with, litigation with a subcontractor or vendor as a result of such direction by the Commission, the Contractor may request the State of Connecticut to enter into any such litigation or negotiation prior thereto to protect the interests of the State and the State may so enter.

10. **Executive Orders.** This Contract is subject to the provisions of Executive Order No. Three of Governor Thomas J. Meskill, promulgated June 16, 1971, concerning labor employment practices, Executive Order No. Seventeen of Governor Thomas J. Meskill, promulgated February 15, 1973, concerning the listing of employment openings and Executive Order No. Sixteen of Governor John G. Rowland promulgated August 4, 1999, concerning violence in the workplace, all of which are incorporated into and are made a part of the Contract as if they had been fully set forth in it. The Contract may also be subject to Executive Order No. 14 of Governor M. Jodi Rell, promulgated April 17, 2006, concerning procurement of cleaning products and services and to Executive Order No. 49 of Governor Dannel P. Malloy, promulgated May 22, 2015, mandating disclosure of certain gifts to public employees and contributions to certain candidates for office. If Executive Order 14 and/or Executive Order 49 are applicable, they are deemed to be incorporated into and are made a part of the Contract as if they had been fully set forth in it. At the Contractor's request, the Institution or DAS shall provide a copy of these orders to the Contractor.
11. **Force Majeure.** If the performance of obligations under this Contract are rendered impossible or hazardous or is otherwise prevented or impaired due to illness, accident, Act(s) of God, riots, strikes, labor difficulties, epidemics, earthquakes, and/or any other cause or event, similar or dissimilar, beyond the control of the Contractor, then each

party's obligations to the other under this Contract shall be excused and neither party shall have any liability to the other under or in connection with this Contract.

12. **Campaign Contribution Restrictions.** For all state contracts as defined in Connecticut General Statutes § 9-612(g)(2), as amended by Public Act 10-1 having a value in a calendar year of \$50,000 or more or a combination or series of such agreements or contracts having a value of \$100,000 or more, the authorized signatory to this Agreement expressly acknowledges receipt of the State Election Enforcement Commission's notice advising state contractors of state campaign contribution and solicitation prohibitions, and will inform its principals of the contents of the Notice, referenced herein as Exhibit A.
13. **Contract Assignment.** No right or duty, in whole or in part, of the Contractor under this Agreement may be assigned or delegated without the prior written consent of the institution.
14. **Confidential Information.** The Contractor acknowledges that it may have access to Confidential Information (as hereinafter defined). The Contractor agrees that it will use the Confidential Information solely for the purpose of performing its duties as a consultant and agrees that it will not divulge, furnish, publish or use for its own benefit or for the direct or indirect benefit of any other person or entity, whether or not for monetary gain, any Confidential Information.  
  
For purposes of this Agreement, the term "Confidential Information" shall mean (i) all information related to the business operations, marketing plans, financial position and (ii) other business information and any other information disclosed to the Contractor. Confidential Information shall not include information which (i) is or becomes part of the public domain through no act or omission attributable to the Contractor, (ii) is released after prior written authorization or (iii) the Contractor receives from any third party who is unrelated to it and who is not under any obligation to maintain the confidentiality of such information.
15. **Family Educational Rights and Privacy Act (FERPA).** In all respects, Contractor shall comply with the provisions of the Family Educational Rights and Privacy Act (FERPA). For purposes of this contract, FERPA includes any amendments or other relevant provisions of federal law, as well as all requirements of Chapter 99 of Title 34 of the Code of Federal Regulations, as amended from time to time. Nothing in this agreement may be construed to allow Contractor to maintain, use, disclose or share student information in a manner not allowed by federal law or regulation or by this contract. Contractor agrees that it shall not provide any student information obtained under this contract to any party ineligible to receive data protected by FERPA. This section shall survive the termination, cancellation or expiration of the contract.
16. **Summary of State Ethics Laws.** Pursuant to the requirements of section 1-101qq of the Connecticut General Statutes, the summary of State ethic laws developed by the State Ethics Commission pursuant to section 1-81b of the Connecticut General Statutes is incorporated by reference into and made a part of the contract as if the summary had been fully set forth in the contract.

17. **Whistleblower.** This contract may be subject to the provisions of Section 4-61dd of the Connecticut General Statutes. In accordance with this statute, if an officer, employee or appointing authority of the Contractor takes or threatens to take any personnel action against any employee of the Contractor in retaliation for such employee's disclosure of information to any employee of the contracting state or quasi-public agency or the Auditors of Public Accounts or the Attorney General under the provisions of subsection (a) of such statute, the Contractor shall be liable for a civil penalty of not more than five thousand dollars for each offense, up to a maximum of twenty percent (20%) of the value of this contract. Each violation shall be a separate and distinct offense and in the case of a continuing violation, each calendar day's continuance of the violation shall be deemed to be a separate and distinct offense. The State may request that the Attorney General bring a civil action in the Superior Court for the Judicial District of Hartford to seek imposition and recovery of such civil penalty. In accordance with subsection (f) of such statute, each large state contractor, as defined in the statute, shall post a notice of the provisions of the statute relating to large state contractors in a conspicuous place which is readily available for viewing by the employees of the contractor.
18. **Disclosure of Records.** This Contract may be subject to the provisions of section 1-218 of the Connecticut General Statutes. In accordance with this statute, each contract in excess of two million five hundred thousand dollars between a public agency and a person for the performance of a governmental function shall (a) provide that the public agency is entitled to receive a copy of records and files related to the performance of the governmental function, and (b) indicate that such records and files are subject to the Freedom of Information Act (FOIA) and may be disclosed by the public agency pursuant to FOIA. No request to inspect or copy such records or files shall be valid unless the request is made to the public agency in accordance with FOIA. Any complaint by a person who is denied the right to inspect or copy such records or files shall be brought to the Freedom of Information Commission in accordance with the provisions of sections 1-205 and 1-206 of the Connecticut General Statutes.
19. **Audit Requirements for State Grants.** For purposes of this clause, the word "Contractor" shall be read to mean "nonstate entity," as that term is defined in Conn. Gen. Stat. § 4-230. The Contractor shall provide for an annual financial audit acceptable to the Institution for any expenditure of State-awarded funds made by the Contractor. Such audit shall include management letters and audit recommendations. The State Auditors of Public Accounts shall have access to all records and accounts for the fiscal year(s) in which the award was made. The Contractor will comply with federal and State single audit standards as applicable.
20. **Audit Requirements for Federal Grants.** For U.S. based, non-profit Contractors expending \$500,000 or more of federal awards in one year: The Contractor agrees to comply with the requirements of Office of Management and Budget (OMB) Circular A-133. Contractor further agrees to provide the Institution with copies of all independent auditors' reports which cover the period of performance of this contract. Contractor will provide a copy of its response to auditors' reports and, in instances of non-compliance, a plan for corrective action. All records and reports prepared in accordance with the requirements of OMB Circular A-133 shall be made available for review or audit by appropriate officials of the Federal agency, Institution, or the General Accounting Office (GAO) during normal business hours.

For U.S. based, non-profit Contractors expending less than \$500,000 of Federal awards in one year: Contractor agrees that all records pertaining to this agreement will be made available for review or audit by appropriate officials of the Federal agency, Institution, or the GAO during normal business hours.

21. **Professional Standards.** In rendering services under this contract, the Contractor shall conform to high professional standards of work and business ethic. The Contractor warrants that the services shall be performed: 1) in a professional and workmanlike manner; and 2) in accordance with generally and currently accepted principles and practices. During the term of this contract, the Contractor agrees to provide to Institution in a good and faithful manner, using its best efforts and in a manner that shall promote the interests of Institution, such services as Institution requests, provided in the contract.

22. **Contractor's Standards of Conduct.**

- (a) In order to insure the orderly and efficient performance of duties and services at the Institution and to protect the health, safety and welfare of all members of Institution's community the Contractor agrees that the following items are strictly prohibited while performing services under this Agreement:
- i. Use or possession of drugs or alcohol;
  - ii. Possession of firearms or illegal weapons anywhere on campus property including vehicles;
  - iii. Smoking in buildings;
  - iv. Harassment (sexual, racial or otherwise) or intimidation of anyone on the premises of the campus;
  - v. Violation of applicable traffic or public safety regulations or of Institution rules and procedures;
  - vi. Unauthorized use of Institution vehicles, equipment or property;
  - vii. Use of University telephones for personal business;
  - viii. Removal or theft of University property;
  - ix. Unauthorized duplication or possession of University keys;
  - x. Transfer of personal identification card or of parking pass to unauthorized personnel;
  - xi. Conduct or behavior that endangers the health, safety and welfare of any member of the public or of the University community;
  - xii. Interference with the work of other employees;
  - xiii. Work attire other than the specified uniform; and
  - xiv. Loud, vulgar behavior or the use of profanity.
- (b) Violation of Standards: Contractor will require its employees to comply with the standards listed in Professional Standards and 22 (a) above. The Institution may, at its discretion, recommend discharge of any employee of the Contractor found to be in

violation of the standards listed in 1.1(i) or 1.2(a) above, or in violation of any law or standards adopted by the Institution from time to time, as required, to protect the health, safety and welfare of the Institution's community. Upon request of the Institution, Contractor shall remove any of its employees that violate said standards from assignments to be performed under this Agreement.

**V. ACCEPTANCE OF AGREEMENT**

IN WITNESS WHEREOF, the parties have executed this Contract by their duly authorized representatives with full knowledge of and agreement with its terms and conditions.

<b>[Eastern Connecticut State University</b>	<b>[Enter Contractor Business Name]</b>
By: _____	By: _____
Print Name: _____	Print Name: _____
Title: _____	Title: _____
Date: _____	Date: _____

**By the Connecticut Attorney General**

This contract template, having been reviewed and approved as to form by the Connecticut Attorney General, is exempt from review pursuant to a Memorandum of Agreement between the Connecticut State Colleges and Universities, Board of Regents for Higher Education and the Connecticut Attorney General dated December 30, 2015. Therefore, no signature is required below.

CONNECTICUT STATE ELECTIONS ENFORCEMENT COMMISSION

EXHIBIT A - SEEC NOTICE



Rev. 1/11

---

**NOTICE TO EXECUTIVE BRANCH STATE CONTRACTORS AND PROSPECTIVE STATE CONTRACTORS OF CAMPAIGN CONTRIBUTION AND SOLICITATION LIMITATIONS**

This notice is provided under the authority of Connecticut General Statutes §9-612(g)(2), as amended by P.A. 10-1, and is for the purpose of informing state contractors and prospective state contractors of the following law (*italicized words are defined below*):

---

**CAMPAIGN CONTRIBUTION AND SOLICITATION LIMITATIONS**

---

*No state contractor, prospective state contractor, principal of a state contractor or principal of a prospective state contractor*, with regard to a *state contract* or *state contract solicitation* with or from a state agency in the executive branch or a quasi-public agency or a holder, or principal of a holder of a valid prequalification certificate, shall make a contribution to (i) an exploratory committee or candidate committee established by a candidate for nomination or election to the office of Governor, Lieutenant Governor, Attorney General, State Comptroller, Secretary of the State or State Treasurer, (ii) a political committee authorized to make contributions or expenditures to or for the benefit of such candidates, or (iii) a party committee (which includes town committees).

In addition, no holder or principal of a holder of a valid prequalification certificate, shall make a contribution to (i) an exploratory committee or candidate committee established by a candidate for nomination or election to the office of State senator or State representative, (ii) a political committee authorized to make contributions or expenditures to or for the benefit of such candidates, or (iii) a party committee.

On and after January 1, 2011, no state contractor, prospective state contractor, principal of a state contractor or principal of a prospective state contractor, with regard to a state contract or state contract solicitation with or from a state agency in the executive branch or a quasi-public agency or a holder, or principal of a holder of a valid prequalification certificate, shall **knowingly solicit** contributions from the state contractor's or prospective state contractor's employees or from a *subcontractor* or *principals of the subcontractor* on behalf of (i) an exploratory committee or candidate committee established by a candidate for nomination or election to the office of Governor, Lieutenant Governor, Attorney General, State Comptroller, Secretary of the State or State Treasurer, (ii) a political committee authorized to make contributions or expenditures to or for the benefit of such candidates, or (iii) a party committee.

---

**DUTY TO INFORM**

---

---

State contractors and prospective state contractors are required to inform their principals of the above prohibitions, as applicable, and the possible penalties and other consequences of any violation thereof.

---

### **PENALTIES FOR VIOLATIONS**

---

Contributions or solicitations of contributions made in violation of the above prohibitions may result in the following civil and criminal penalties:

**Civil penalties** - Up to \$2,000 or twice the amount of the prohibited contribution, whichever is greater, against a principal or a contractor. Any state contractor or prospective state contractor which fails to make reasonable efforts to comply with the provisions requiring notice to its principals of these prohibitions and the possible consequences of their violations may also be subject to civil penalties of up to \$2,000 or twice the amount of the prohibited contributions made by their principals.

**Criminal penalties** - Any knowing and willful violation of the prohibition is a Class D felony, which may subject the violator to imprisonment of not more than 5 years, or not more than \$5,000 in fines, or both.

---

### **CONTRACT CONSEQUENCES**

---

In the case of a state contractor, contributions made or solicited in violation of the above prohibitions may result in the contract being voided.

In the case of a prospective state contractor, contributions made or solicited in violation of the above prohibitions shall result in the contract described in the state contract solicitation not being awarded to the prospective state contractor, unless the State Elections Enforcement Commission determines that mitigating circumstances exist concerning such violation.

The State shall not award any other state contract to anyone found in violation of the above prohibitions for a period of one year after the election for which such contribution is made or solicited, unless the State Elections Enforcement Commission determines that mitigating circumstances exist concerning such violation.

Additional information may be found on the website of the State Elections Enforcement Commission, [www.ct.gov/seec](http://www.ct.gov/seec). Click on the link to “Lobbyist/Contractor Limitations.”

---

### **DEFINITIONS**

---

---

“State contractor” means a person, business entity or nonprofit organization that enters into a state contract. Such person, business entity or nonprofit organization shall be deemed to be a state contractor until December thirty-first of the year in which such contract terminates. “State contractor” does not include a municipality or any other political subdivision of the state, including any entities or associations duly created by the municipality or political subdivision exclusively amongst themselves to further any purpose authorized by statute or charter, or an employee in the executive or legislative branch of state government or a quasi-public agency, whether in the classified or unclassified service and full or part-time, and only in such person's capacity as a state or quasi-public agency employee.

“Prospective state contractor” means a person, business entity or nonprofit organization that (i) submits a response to a state contract solicitation by the state, a state agency or a quasi-public agency, or a proposal in response to a request for proposals by the state, a state agency or a quasi-public agency, until the contract has been entered into, or (ii) holds a valid prequalification certificate issued by the Commissioner of Administrative Services under section 4a-100. “Prospective state contractor” does not include a municipality or any other political subdivision of the state, including any entities or associations duly created by the municipality or political subdivision exclusively amongst themselves to further any purpose authorized by statute or charter, or an employee in the executive or legislative branch of state government or a quasi-public agency, whether in the classified or unclassified service and full or part-time, and only in such person's capacity as a state or quasi-public agency employee.

“Principal of a state contractor or prospective state contractor” means (i) any individual who is a member of the board of directors of, or has an ownership interest of five per cent or more in, a state contractor or prospective state contractor, which is a business entity, except for an individual who is a member of the board of directors of a nonprofit organization, (ii) an individual who is employed by a state contractor or prospective state contractor, which is a business entity, as president, treasurer or executive vice president, (iii) an individual who is the chief executive officer of a state contractor or prospective state contractor, which is not a business entity, or if a state contractor or prospective state contractor has no such officer, then the officer who duly possesses comparable powers and duties, (iv) an officer or an employee of any state contractor or prospective state contractor who has *managerial or discretionary responsibilities with respect to a state contract*, (v) the spouse or a *dependent child* who is eighteen years of age or older of an individual described in this subparagraph, or (vi) a political committee established or controlled by an individual described in this subparagraph or the business entity or nonprofit organization that is the state contractor or prospective state contractor.

“State contract” means an agreement or contract with the state or any state agency or any quasi-public agency, let through a procurement process or otherwise, having a value of fifty thousand dollars or more, or a combination or series of such agreements or contracts having a value of one hundred thousand dollars or more in a calendar year, for (i) the rendition of services, (ii) the furnishing of any goods, material, supplies, equipment or any items of any kind, (iii) the construction, alteration or repair of any public building or public work, (iv) the acquisition, sale or lease of any land or building, (v) a licensing arrangement, or (vi) a grant, loan or loan guarantee. “State contract” does not include any agreement or contract with the state, any state agency or any quasi-public agency that is exclusively federally funded, an education loan, a loan to an individual for other than commercial purposes or any agreement or contract between the state or any state agency and the United States Department of the Navy or the United

“State contract solicitation” means a request by a state agency or quasi-public agency, in whatever form issued, including, but not limited to, an invitation to bid, request for proposals, request for information or request for quotes, inviting bids, quotes or other types of submittals, through a competitive procurement process or another process authorized by law waiving competitive procurement.

“Managerial or discretionary responsibilities with respect to a state contract” means having direct, extensive and substantive responsibilities with respect to the negotiation of the state contract and not peripheral, clerical or ministerial responsibilities.

“Dependent child” means a child residing in an individual’s household who may legally be claimed as a dependent on the federal income tax of such individual.

“Solicit” means (A) requesting that a contribution be made, (B) participating in any fund-raising activities for a candidate committee, exploratory committee, political committee or party committee, including, but not limited to, forwarding tickets to potential contributors, receiving contributions for transmission to any such committee or bundling contributions, (C) serving as chairperson, treasurer or deputy treasurer of any such committee, or (D) establishing a political committee for the sole purpose of soliciting or receiving contributions for any committee. Solicit does not include: (i) making a contribution that is otherwise permitted by Chapter 155 of the Connecticut General Statutes; (ii) informing any person of a position taken by a candidate for public office or a public official, (iii) notifying the person of any activities of, or contact information for, any candidate for public office; or (iv) serving as a member in any party committee or as an officer of such committee that is not otherwise prohibited in this section.

“Subcontractor” means any person, business entity or nonprofit organization that contracts to perform part or all of the obligations of a state contractor's state contract. Such person, business entity or nonprofit organization shall be deemed to be a subcontractor until December thirty first of the year in which the subcontract terminates. “Subcontractor” does not include (i) a municipality or any other political subdivision of the state, including any entities or associations duly created by the municipality or political subdivision exclusively amongst themselves to further any purpose authorized by statute or charter, or (ii) an employee in the executive or legislative branch of state government or a quasi-public agency, whether in the classified or unclassified service and full or part-time, and only in such person's capacity as a state or quasi-public agency employee.

“Principal of a subcontractor” means (i) any individual who is a member of the board of directors of, or has an ownership interest of five per cent or more in, a subcontractor, which is a business entity, except for an individual who is a member of the board of directors of a nonprofit organization, (ii) an individual who is employed by a subcontractor, which is a business entity, as president, treasurer or executive vice president, (iii) an individual who is the chief executive officer of a subcontractor, which is not a business entity, or if a subcontractor has no such officer, then the officer who duly possesses comparable powers

---

and duties, (iv) an officer or an employee of any subcontractor who has managerial or discretionary responsibilities with respect to a subcontract with a state contractor, (v) the spouse or a dependent child who is eighteen years of age or older of an individual described in this subparagraph, or (vi) a political committee established or controlled by an individual described in this subparagraph or the business entity or nonprofit organization that is the subcontractor.

**COMMISSION ON HUMAN RIGHTS AND OPPORTUNITIES  
CONTRACT COMPLIANCE REGULATIONS**

**IMPORTANT**

All bidders are required to file an acknowledgement of receipt of the "NOTIFICATION TO BIDDERS" form with their proposal.

Before a contract award can be made for this project, the successful low bidder will be required to file the following forms, developed by The Commission on Rights and Opportunities pursuant to Connecticut General Statutes Section 4-114a.

1) Contractors Minority Business Enterprises Utilization Form

2) Affidavit (when applicable)

3) CHRO Certificate of Compliance - Pursuant to section 46a-68c of the Connecticut General Statutes, each contractor with fifty or more employees awarded a public works contract in excess of fifty thousand dollars in any fiscal year, but not subject to the provisions of section 46a-68d, shall develop and file with the commission an affirmative action plan which shall comply with regulations adopted by said commission. Failure to develop an approved an approved affirmative action plan pursuant to this section shall act as a bar to bidding on or the award of future contracts until such requirement has been met. When the commission approves an affirmative action plan pursuant to this section, it shall issue a certificate of compliance to the contractor. This certificate shall be prima facie proof of the contractor's eligibility to bid or be awarded contracts for a period of two years from the date of the certificate.

# Form of Proposal - Set Aside Worksheet

(for \$50k-500k projects)

Project Number: ECSU 2020-8

Project Name: BASEBALL, SOFTBALL, & RUGBY FIELD RENOVATION

	Subcontractor Name	Class of work	SBE	MBE/WBE	Prime Contractor self performing \$	Subcontract amounts
1						\$
2						\$
3						\$
4						\$
5						\$
6						\$
7						\$
8						\$
9	Prime Contractor Total	Bidder is the Prime Contractor			\$	
10	SBE Subtotal	Add SBE subcontract amounts from above list and enter total at right				\$
11	MBE/WBE Subtotal	Add MBE/WBE subcontract amounts from the list and enter total to the right				\$
12	Lump Sum base bid	Enter total lump sum base bid from bid submittal form				\$
15	<b>SBE Percentage</b>	Divide line 10 by line 9. Enter % to the right				%
16	<b>MBE/WBE Percentage</b>	Divide line 11 by line 10. Enter % to the right.				%

In determining and ensuring compliance with CHRO requirements this worksheet must be submitted as part of the bid submittal package. Failure to do so shall be grounds for disqualification of the bid. Compliance determination shall initially be based on the base bid sum. However, for bid solicitations requiring acceptance of Alternates or Supplemental bids, a revised worksheet shall be required prior to issuance of contract.

**The SBE requirement is 100% of the entire bid total with 6.25% to an MBE/WBE.**

Each bidder shall submit, as part of their proposal, copies of Certificates of Eligibility for each set aside subcontractor or "screen shots" from the State of Connecticut Supplier Diversity web site for each set aside subcontractor showing name and address, certification type and certificate expiration date.

Vendor Company Name (Prime Contractor) \_\_\_\_\_

Authorized signature \_\_\_\_\_ Date \_\_\_\_\_

**COMMISSION ON HUMAN RIGHTS AND OPPORTUNITIES  
CONTRACT COMPLIANCE REGULATIONS  
NOTIFICATION TO BIDDERS**

(Revised 09/17/07)

The contract to be awarded is subject to contract compliance requirements mandated by Sections 4a-60 and 4a-60a of the Connecticut General Statutes; and, when the awarding agency is the State, Sections 46a-71(d) and 46a-81i(d) of the Connecticut General Statutes. There are Contract Compliance Regulations codified at Section 46a-68j-21 through 43 of the Regulations of Connecticut State Agencies, which establish a procedure for awarding all contracts covered by Sections 4a-60 and 46a-71(d) of the Connecticut General Statutes.

According to Section 46a-68j-30(9) of the Contract Compliance Regulations, every agency awarding a contract subject to the contract compliance requirements has an obligation to "aggressively solicit the participation of legitimate minority business enterprises as bidders, contractors, subcontractors and suppliers of materials." "Minority business enterprise" is defined in Section 4a-60 of the Connecticut General Statutes as a business wherein fifty-one percent or more of the capital stock, or assets belong to a person or persons: "(1) Who are active in daily affairs of the enterprise; (2) who have the power to direct the management and policies of the enterprise; and (3) who are members of a minority, as such term is defined in subsection (a) of Section 32-9n." "Minority" groups are defined in Section 32-9n of the Connecticut General Statutes as "(1) Black Americans . . . (2) Hispanic Americans . . . (3) persons who have origins in the Iberian Peninsula . . . (4) Women . . . (5) Asian Pacific Americans and Pacific Islanders; (6) American Indians . . ." An individual with a disability is also a minority business enterprise as provided by Section 4a-60g of the Connecticut General Statutes. The above definitions apply to the contract compliance requirements by virtue of Section 46a-68j-21(11) of the Contract Compliance Regulations.

The awarding agency will consider the following factors when reviewing the bidder's qualifications under the contract compliance requirements:

- (a) the bidder's success in implementing an affirmative action plan;
- (b) the bidder's success in developing an apprenticeship program complying with Sections 46a-68-1 to 46a-68-17 of the Administrative Regulations of Connecticut State Agencies, inclusive;
- (c) the bidder's promise to develop and implement a successful affirmative action plan;
- (d) the bidder's submission of employment statistics contained in the "Employment Information Form", indicating that the composition of its workforce is at or near parity when compared to the racial and sexual composition of the workforce in the relevant labor market area; and
- (e) the bidder's promise to set aside a portion of the contract for legitimate minority business enterprises. See Section 46a-68j-30(10)(E) of the Contract Compliance Regulations.

---

**INSTRUCTIONS AND OTHER INFORMATION**

The following BIDDER CONTRACT COMPLIANCE MONITORING REPORT must be completed in full, signed, and submitted with the bid for this contract. The contract awarding agency and the Commission on Human Rights and Opportunities will use the information contained thereon to determine the bidders compliance to Sections 4a-60 and 4a-60a CONN. GEN. STAT., and Sections 46a-68j-23 of the Regulations of Connecticut State Agencies regarding equal employment opportunity, and the bidder's  good faith efforts to include minority business enterprises as subcontractors and suppliers for the work of the contract.

1) **Definition of Small Contractor**

Section 4a-60g CONN. GEN. STAT. defines a small contractor as a company that has been doing business under the same management and control and has maintained its principal place of business in Connecticut for a one year period immediately prior to its application for certification under this section, had gross revenues not exceeding ten million dollars in the most recently completed fiscal year, and at least fifty-one percent of the ownership of which is held by a person or persons who are active in the daily affairs of the company, and have the power to direct the management and policies of the company, except that a nonprofit corporation shall be construed to be a small contractor if such nonprofit corporation meets the requirements of subparagraphs (A) and (B) of subdivision 4a-60g CONN. GEN. STAT.

**MANAGEMENT:** Managers plan, organize, direct, and control the major functions of an organization through subordinates who are at the managerial or supervisory level. They make policy decisions and set objectives for the company or departments. They are not usually directly involved in production or providing services. Examples include top executives, public relations managers, managers of operations specialties (such as financial, human resources, or purchasing managers), and construction and engineering managers.

**BUSINESS AND FINANCIAL OPERATIONS:** These occupations include managers and professionals who work with the financial aspects of the business. These occupations include accountants and auditors, purchasing agents, management analysts, labor relations specialists, and budget, credit, and financial analysts.

**MARKETING AND SALES:** Occupations related to the act or process of buying and selling products and/or services such as sales engineer, retail sales workers and sales representatives including wholesale.

**LEGAL OCCUPATIONS:** In-House Counsel who is charged with providing legal advice and services in regards to legal issues that may arise during the course of standard business practices. This category also includes assistive legal occupations such as paralegals, legal assistants.

**COMPUTER SPECIALISTS:** Professionals responsible for the computer operations within a company are grouped in this category. Examples of job titles in this category include computer programmers, software engineers, database administrators, computer scientists, systems analysts, and computer support specialists

**ARCHITECTURE AND ENGINEERING:** Occupations related to architecture, surveying, engineering, and drafting are included in this category. Some of the job titles in this category include electrical and electronic engineers, surveyors, architects, drafters, mechanical engineers, materials engineers, mapping technicians, and civil engineers.

**OFFICE AND ADMINISTRATIVE SUPPORT:** All clerical-type work is included in this category. These jobs involve the preparing, transcribing, and preserving of written communications and records; collecting accounts; gathering and distributing information; operating office machines and electronic data processing equipment; and distributing mail. Job titles listed in this category include telephone operators, bill and account collectors, customer service representatives, dispatchers, secretaries and administrative assistants, computer operators and clerks (such as payroll, shipping, stock, mail and file).

**BUILDING AND GROUNDS CLEANING AND MAINTENANCE:** This category includes occupations involving landscaping, housekeeping, and janitorial services. Job titles found in this category include supervisors of landscaping or housekeeping, janitors, maids, grounds maintenance workers, and pest control workers.

**CONSTRUCTION AND EXTRACTION:** This category includes construction trades and related occupations. Job titles found in this category include boilermakers, masons (all types), carpenters, construction laborers, electricians, plumbers (and related trades), roofers, sheet metal workers, elevator installers, hazardous materials removal workers, paperhangers, and painters. Paving, surfacing, and tamping equipment operators; drywall and ceiling tile installers; and carpet, floor and tile installers and finishers are also included in this category. First line supervisors, foremen, and helpers in these trades are also grouped in this category..

**INSTALLATION, MAINTENANCE AND REPAIR:** Occupations involving the installation, maintenance, and repair of equipment are included in this group. Examples of job titles found here are heating, ac, and refrigeration mechanics and installers; telecommunication line installers and repairers; heavy vehicle and mobile equipment service technicians and mechanics; small engine mechanics; security and fire alarm systems installers; electric/electronic repair, industrial, utility and transportation equipment; millwrights; riggers; and manufactured building and mobile home installers. First line supervisors, foremen, and helpers for these jobs are also included in the category.

**MATERIAL MOVING WORKERS:** The job titles included in this group are Crane and tower operators; dredge, excavating, and lading machine operators; hoist and winch operators; industrial truck and tractor operators; cleaners of vehicles and equipment; laborers and freight, stock, and material movers, hand; machine feeders and offbearers; packers and packagers, hand; pumping station operators; refuse and recyclable material collectors; and miscellaneous material moving workers.

**PRODUCTION WORKERS:** The job titles included in this category are chemical production machine setters, operators and tenders; crushing/grinding workers; cutting workers; inspectors, testers sorters, samplers, weighers; precious stone/metal workers; painting workers; cementing/gluing machine operators and tenders; etchers/engravers; molders, shapers and casters except for metal and plastic; and production workers.

3) Definition of Racial and Ethnic Terms (as used in Part IV Bidder Employment Information) (Page 3)

<p><u>White</u> (not of Hispanic Origin)- All persons having origins in any of the original peoples of Europe, North Africa, or the Middle East.</p> <p><u>Black</u>(not of Hispanic Origin)- All persons having origins in any of the Black racial groups of Africa.</p> <p><u>Hispanic</u>- All persons of Mexican, Puerto Rican, Cuban, Central or South American, or other Spanish culture or origin, regardless of race.</p>	<p><u>Asian or Pacific Islander</u>- All persons having origins in any of the original peoples of the Far East, Southeast Asia, the Indian subcontinent, or the Pacific Islands. This area includes China, India, Japan, Korea, the Philippine Islands, and Samoa.</p> <p><u>American Indian or Alaskan Native</u>- All persons having origins in any of the original peoples of North America, and who maintain cultural identification through tribal affiliation or community recognition.</p>
---	---

**BIDDER CONTRACT COMPLIANCE MONITORING REPORT**

**PART I - Bidder Information**

<p>Company Name Street Address City &amp; State Chief Executive</p>	<p>Bidder Federal Employer Identification Number _____ Or Social Security Number _____</p>
<p>Major Business Activity (brief description)</p>	<p>Bidder Identification (response optional/definitions on page 1)</p> <p>-Bidder is a small contractor. Yes__ No__ -Bidder is a minority business enterprise Yes__ No__ (If yes, check ownership category) Black__ Hispanic__ Asian American__ American Indian/Alaskan Native__ Iberian Peninsula__ Individual(s) with a Physical Disability__ Female__</p>
<p>Bidder Parent Company (If any)</p>	<p>- Bidder is certified as above by State of CT Yes__ No__</p>
<p>Other Locations in Ct. (If any)</p>	<p>- DAS Certification Number _____</p>

**PART II - Bidder Nondiscrimination Policies and Procedures**

<p>1. Does your company have a written Affirmative Action/Equal Employment Opportunity statement posted on company bulletin boards? Yes__ No__</p>	<p>7. Do all of your company contracts and purchase orders contain non-discrimination statements as required by Sections 4a-60 &amp; 4a-60a Conn. Gen. Stat.? Yes__ No__</p>
<p>2. Does your company have the state-mandated sexual harassment prevention in the workplace policy posted on company bulletin boards? Yes__ No__</p>	<p>8. Do you, upon request, provide reasonable accommodation to employees, or applicants for employment, who have physical or mental disability? Yes__ No__</p>
<p>3. Do you notify all recruitment sources in writing of your company's Affirmative Action/Equal Employment Opportunity employment policy? Yes__ No__</p>	<p>9. Does your company have a mandatory retirement age for all employees? Yes__ No__</p>
<p>4. Do your company advertisements contain a written statement that you are an Affirmative Action/Equal Opportunity Employer? Yes__ No__</p>	<p>10. If your company has 50 or more employees, have you provided at least two (2) hours of sexual harassment training to all of your supervisors? Yes__ No__ NA__</p>
<p>5. Do you notify the Ct. State Employment Service of all employment openings with your company? Yes__ No__</p>	<p>11. If your company has apprenticeship programs, do they meet the Affirmative Action/Equal Employment Opportunity requirements of the apprenticeship standards of the Ct. Dept. of Labor? Yes__ No__ NA__</p>
<p>6. Does your company have a collective bargaining agreement with workers? Yes__ No__ 6a. If yes, do the collective bargaining agreements contain non-discrimination clauses covering all workers? Yes__ No__ 6b. Have you notified each union in writing of your commitments under the nondiscrimination requirements of contracts with the state of Ct? Yes__ No__</p>	<p>12. Does your company have a written affirmative action Plan? Yes__ No__ If no, please explain.</p> <p>13. Is there a person in your company who is responsible for equal employment opportunity? Yes__ No__ If yes, give name and phone number.</p>

1. Will the work of this contract include subcontractors or suppliers? Yes\_\_ No\_\_

1a. If yes, please list all subcontractors and suppliers and report if they are a small contractor and/or a minority business enterprise. (defined on page 1 / use additional sheet if necessary)

1b. Will the work of this contract require additional subcontractors or suppliers other than those identified in 1a. above?

Yes\_\_ No\_\_

**PART IV - Bidder Employment Information**

Date:

JOB CATEGORY *	OVERALL TOTALS	WHITE (not of Hispanic origin)		BLACK (not of Hispanic origin)		HISPANIC		ASIAN or PACIFIC ISLANDER		AMERICAN INDIAN or ALASKAN NATIVE	
		Male	Female	Male	Female	Male	Female	Male	Female	male	female
Management											
Business & Financial Ops											
Marketing & Sales											
Legal Occupations											
Computer Specialists											
Architecture/Engineering											
Office & Admin Support											
Bldg/ Grounds Cleaning/Maintenance											
Construction & Extraction											
Installation , Maintenance & Repair											
Material Moving Workers											
Production Occupations											
TOTALS ABOVE											
Total One Year Ago											
FORMAL ON THE JOB TRAINEES (ENTER FIGURES FOR THE SAME CATEGORIES AS ARE SHOWN ABOVE)											
Apprentices											
Trainees											

\*NOTE: JOB CATEGORIES CAN BE CHANGED OR ADDED TO (EX. SALES CAN BE ADDED OR REPLACE A CATEGORY NOT USED IN YOUR COMPANY)

1. Which of the following recruitment sources are used by you? (Check yes or no, and report percent used)				2. Check (X) any of the below listed requirements that you use as a hiring qualification  (X)		3. Describe below any other practices or actions that you take which show that you hire, train, and promote employees without discrimination
SOURCE	YES	NO	% of applicants provided by source			
State Employment Service					Work Experience	
Private Employment Agencies					Ability to Speak or Write English	
Schools and Colleges					Written Tests	
Newspaper Advertisement					High School Diploma	
Walk Ins					College Degree	
Present Employees					Union Membership	
Labor Organizations					Personal Recommendation	
Minority/Community Organizations					Height or Weight	
Others (please identify)					Car Ownership	
					Arrest Record	
					Wage Garnishments	

Certification (Read this form and check your statements on it CAREFULLY before signing). I certify that the statements made by me on this BIDDER CONTRACT COMPLIANCE MONITORING REPORT are complete and true to the best of my knowledge and belief, and are made in good faith. I understand that if I knowingly make any misstatements of facts, I am subject to be declared in non-compliance with Section 4a-60, 4a-60a, and related sections of the CONN. GEN. STAT.

(Signature)	(Title)	(Date Signed)	(Telephone)
-------------	---------	---------------	-------------

AMENDMENT NO. 1-A

.....

1. PREVAILING WAGE RATES

Notwithstanding the amount of the proposal or ECSU's estimated cost for this project, prevailing wages are required on this project, in accordance with the schedule provided in the proposal documents, pursuant to Connecticut General Statutes Section 31-53 (a-f, h), as amended.

2. SET-ASIDE / MINORITY BUSINESS ENTERPRISE PARTICIPATION

This project requires set-aside and minority business enterprise participation as stated in Section 7 (f, g, h, i) on the Project Data Sheet / Proposal Form. The contractor who is selected to perform this state project must file and receive an approved Affirmative Action Plan by the Commission on Human Rights and Opportunities.

This project is subject to the State SET ASIDE goals and **NEW STATUTORY CHANGES TO 4a-60g effective 10/1/13** as it relates to new self-performance and subcontracting requirements.

Executive Order No. 14: This Agreement is subject to the provisions of Executive Order No. 14 of Governor M. Jodi Rell, promulgated on April 17, 2006. Pursuant to this Executive Order, the Contractor shall use cleaning and/or sanitizing products having properties that minimize potential impacts on human health and the environment, consistent with maintaining clean and sanitary facilities.



## STATE OF CONNECTICUT GIFT AND CAMPAIGN CONTRIBUTION CERTIFICATION

*Written or electronic certification to accompany a State contract with a value of \$50,000 or more in a calendar or fiscal year, pursuant to C.G.S. §§ 4-250 and 4-252(c); Governor M. Jodi Rell's Executive Orders No. 1, Para. 8, and No. 7C, Para. 10; and C.G.S. §9-612(g)(2)*

### INSTRUCTIONS:

Complete all sections of the form. Attach additional pages, if necessary, to provide full disclosure about any lawful campaign contributions made to campaigns of candidates for statewide public office or the General Assembly, as described herein. Sign and date the form, under oath, in the presence of a Commissioner of the Superior Court or Notary Public. Submit the completed form to the awarding State agency at the time of initial contract execution and if there is a change in the information contained in the most recently filed certification, such person shall submit an updated certification either (i) not later than thirty (30) days after the effective date of such change or (ii) upon the submittal of any new bid or proposal for a contract, whichever is earlier. Such person shall also submit an accurate, updated certification not later than fourteen days after the twelve-month anniversary of the most recently filed certification or updated certification.

**CHECK ONE:**     Initial Certification     12 Month Anniversary Update (Multi-year contracts only.)

Updated Certification because of change of information contained in the most recently filed certification or twelve-month anniversary update.

### GIFT CERTIFICATION:

As used in this certification, the following terms have the meaning set forth below:

- 1) "Contract" means that contract between the State of Connecticut (and/or one or more of its agencies or instrumentalities) and the Contractor, attached hereto, or as otherwise described by the awarding State agency below;
- 2) If this is an Initial Certification, "Execution Date" means the date the Contract is fully executed by, and becomes effective between, the parties; if this is a twelve-month anniversary update, "Execution Date" means the date this certification is signed by the Contractor;
- 3) "Contractor" means the person, firm or corporation named as the contractor below;
- 4) "Applicable Public Official or State Employee" means any public official or state employee described in C.G.S. §4-252(c)(1)(i) or (ii);
- 5) "**Gift**" has the same meaning given that term in C.G.S. § 4-250(1);
- 6) "Principals or Key Personnel" means and refers to those principals and key personnel of the Contractor, and its or their agents, as described in C.G.S. §§ 4-250(5) and 4-252(c)(1)(B) and (C).

I, the undersigned, am a Principal or Key Personnel of the person, firm or corporation authorized to execute this certification on behalf of the Contractor. I hereby certify that, no gifts were made by (A) such person, firm, corporation, (B) any principals and key personnel of the person firm or corporation who participate substantially in preparing bids, proposals or negotiating state contracts or (C) any agent of such, firm, corporation, or principals or key personnel who participates substantially in preparing bids, proposals or negotiating state contracts, to (i) any public official or state employee of the state agency or quasi-public agency soliciting bids or proposals for state contracts who participates substantially in the preparation of bid solicitations or request for proposals for state contracts or the negotiation or award of state contracts or (ii) any public official or state employee of any other state agency, who has supervisory or appointing authority over such state agency or quasi-public agency.

I further certify that no Principals or Key Personnel know of any action by the Contractor to circumvent (or which would result in the circumvention of) the above certification regarding **Gifts** by providing for any other Principals, Key Personnel, officials, or employees of the Contractor, or its or their agents, to make a **Gift** to any Applicable Public Official or State Employee. I further certify that the Contractor made the bid or proposal for the Contract without fraud or collusion with any person.

**CAMPAIGN CONTRIBUTION CERTIFICATION:**

I further certify that, on or after December 31, 2006, neither the Contractor nor any of its principals, as defined in C.G.S. § 9-612(g)(1), has made any **campaign contributions** to, or solicited any contributions on behalf of, any exploratory committee, candidate committee, political committee, or party committee established by, or supporting or authorized to support, any candidate for statewide public office, in violation of C.G.S. § 9-612(g)(2)(A). I further certify that **all lawful campaign contributions** that have been made on or after December 31, 2006 by the Contractor or any of its principals, as defined in C.G.S. § 9-612(g)(1), to, or solicited on behalf of, any exploratory committee, candidate committee, political committee, or party committee established by, or supporting or authorized to support any candidates for statewide public office or the General Assembly, are listed below:

**Lawful Campaign Contributions to Candidates for Statewide Public Office:**

<u>Contribution Date</u>	<u>Name of Contributor</u>	<u>Recipient</u>	<u>Value</u>	<u>Description</u>

**Lawful Campaign Contributions to Candidates for the General Assembly:**

<u>Contribution Date</u>	<u>Name of Contributor</u>	<u>Recipient</u>	<u>Value</u>	<u>Description</u>

Sworn as true to the best of my knowledge and belief, subject to the penalties of false statement.

\_\_\_\_\_  
Printed Contractor Name

\_\_\_\_\_  
**Printed Name of Authorized Official**

\_\_\_\_\_  
**Signature of Authorized Official**

Subscribed and acknowledged before me this \_\_\_\_\_ day of \_\_\_\_\_, 20\_\_\_\_.

\_\_\_\_\_  
**Commissioner of the Superior Court (or Notary Public)**

\_\_\_\_\_  
**My Commission Expires**



## **CAMPAIGN CONTRIBUTION RESTRICTION PROVISION**

1. Campaign Contribution Restrictions. This section (the “CCR Section”) is included here pursuant to Conn. Gen. Stat. § 9-333n and, without limiting its applicability, is made applicable to State Contracts, bid solicitations, request for proposals and prequalification certificates, as the context requires. This CCR Section, without limiting its applicability, is also made applicable to State Agencies, Quasi-public Agencies, the General Assembly, State Contractors, Prospective State Contractors and the holders of valid prequalification certificates, as the context requires.

(a) For purposes of this CCR Section only:

(1) "Quasi-public Agency" means the Connecticut Development Authority, Connecticut Innovations, Incorporated, Connecticut Health and Educational Facilities Authority, Connecticut Higher Education Supplemental Loan Authority, Connecticut Housing Finance Authority, Connecticut Housing Authority, Connecticut Resources Recovery Authority, Connecticut Hazardous Waste Management Service, Capital City Economic Development Authority, Connecticut Lottery Corporation, or as this definition may otherwise be modified by Title 1, Chapter 12 of the Connecticut General Statutes concerning quasi-public agencies.

(2) "State Agency" means any office, department, board, council, commission, institution or other agency in the executive, legislative or judicial branch of State government, or as this definition may otherwise be modified by Title 9, Chapter 150 of the Connecticut General Statutes concerning campaign financing.

(3) "State Contract" means an agreement or contract with the State or any State Agency or any Quasi-public Agency, having a value of fifty thousand dollars or more, or a combination or series of such agreements or contracts having a value of one hundred thousand dollars or more in a fiscal year, for (A) the rendition of personal services, (B) the furnishing of any material, supplies or equipment, (C) the construction, alteration or repair of any public building or public work, (D) the acquisition, sale or lease of any land or building, (E) a licensing arrangement, or (F) a grant, loan or loan guarantee, or as this definition may otherwise be modified by Title 9, Chapter 150 of the Connecticut General Statutes concerning campaign financing.

(4) "State Contractor" means a person, business entity or nonprofit organization that enters into a State Contract. Such person, business entity or nonprofit organization shall be deemed to be a State Contractor until the termination of said contract. "State contractor" does not include a municipality or any other political subdivision of the State or an employee in the executive, legislative or judicial branch of State government or a Quasi-public Agency, whether in the classified or unclassified service and full or part-time, and only in such person's capacity as a State or Quasi-

public Agency employee, or as this definition may otherwise be modified by Title 9, Chapter 150 of the Connecticut General Statutes concerning campaign financing.

(5) "Prospective State Contractor" means a person, business entity or nonprofit organization that (A) submits a bid in response to a bid solicitation by the State, a State Agency or a Quasi-public Agency, or a proposal in response to a request for proposals by the State, a State Agency or a Quasi-public Agency, until the State Contract has been entered into, or (B) holds a valid prequalification certificate issued by the Commissioner of Administrative Services under Section 4a-100 of the Connecticut General Statutes. "Prospective State Contractor" does not include a municipality or any other political subdivision of the State or an employee in the executive, legislative or judicial branch of State government or a Quasi-public Agency, whether in the classified or unclassified service and full or part-time, and only in such person's capacity as a State or Quasi-public Agency employee. Title 9, Chapter 150 of the Connecticut General Statutes concerning campaign financing may modify this definition, which modification shall control.

(6) "Principal of a State Contractor or Prospective State Contractor" (collectively referred to in this CCR Section as "Principal") means (A) an individual who is a member of the board of directors of, or has an ownership interest in, a State Contractor or Prospective State Contractor, which is a business entity, except for an individual who (i) owns less than five per cent of the shares of any such State Contractor or Prospective State Contractor that is a publicly traded corporation, or (ii) is a member of the board of directors of a nonprofit organization qualified under Section 501(c)(3) of the Internal Revenue Code of 1986, or any subsequent corresponding internal revenue code of the United States, as from time to time amended, (B) an individual who is employed by a State Contractor or Prospective State Contractor, which is a business entity, as president, treasurer or executive or senior vice president, (C) an individual who is the chief executive officer of a State Contractor or Prospective State Contractor, which is not a business entity, (D) an employee of any State Contractor or Prospective State Contractor who has managerial or discretionary responsibilities with respect to a State Contract, (E) the spouse or a dependent child of an individual described in this subparagraph, or (F) a political committee established by or on behalf of an individual described in this subparagraph, or as this definition may otherwise be modified by Title 9, Chapter 150 of the Connecticut General Statutes concerning campaign financing.

(b) No State Contractor, Prospective State Contractor or Principal, with regard to a State Contract, bid solicitation or request for proposals with or from a State Agency in the executive branch or a Quasi-public Agency, and no Principal of a holder of a valid prequalification certificate, shall make a contribution to, or solicit contributions on behalf of (1) an exploratory committee or candidate committee established by a candidate for nomination or election to the office of Governor, Lieutenant Governor, Attorney General, State Comptroller, Secretary of the State or State Treasurer, (2) a political committee authorized to make contributions or expenditures to or for the benefit of such candidates, or (3) a party committee.

(c) No State Contractor, Prospective State Contractor or Principal, with regard to a State Contract, bid solicitation or request for proposals with or from the General Assembly, and no Principal of a holder of a valid prequalification certificate, shall make a contribution to, or solicit contributions on behalf of (1) an exploratory committee or candidate committee established by a candidate for nomination or election to the office of State senator or State representative, (2) a political committee authorized to make contributions or expenditures to or for the benefit of such candidates, or (3) a party committee.

(d) If a State Contractor or a Principal of a State Contractor makes or solicits a contribution prohibited under this CCR Section, the contracting State Agency or Quasi-public Agency may void the existing contract with said contractor, and no State Agency or Quasi-public Agency shall award the State Contractor a State Contract or an extension or an amendment to a State Contract for one year after the election for which such contribution is made or solicited.

(e) If a Prospective State Contractor or a Principal of a Prospective State Contractor makes or solicits a contribution prohibited under this CCR Section, no State Agency or Quasi-public Agency shall award the Prospective State Contractor the contract described in the bid solicitation or request for proposals, or any other State Contract for one year after the election for which such contribution is made or solicited.

(f) The chief executive officer of each State Contractor and Prospective State Contractor, or if a State Contractor or Prospective State Contractor has no such officer then the officer who duly possesses and exercises comparable powers and duties, shall certify, in the form of an affidavit executed subject to the penalties of false statement, that: (1) such officer has informed each individual described in subsection (a)(6) of this CCR Section with regard to said State Contractor or Prospective State Contractor concerning the provisions of subsection (b) or (c) of this CCR Section, whichever is applicable, and this subsection (f), (2) no such individual will make or solicit a contribution in violation of the provisions of subsection (b) or (c) of this CCR Section, whichever is applicable, and this subsection (f), and (3) if any such contribution is made or solicited, the State Contractor or Prospective State Contractor, as the context requires, shall not be awarded the contract described in the bid solicitation or request for proposals and shall not be awarded any other State Contract for one year after the election for which such contribution is made or solicited. Such officer shall submit the affidavit to the contracting State Agency or Quasi-public Agency prior to, in the case of an RFP, executing a negotiated contract or prior to, in the case of an ITB, the award and acceptance of a contract. In the case of an application for prequalification to the Connecticut Department of Administrative Services (“DAS”), the application shall not be deemed to be complete until DAS receives the affidavit. The State Contractor or Prospective Contractor shall submit the affidavit on a form which the State Elections Enforcement Commission (“SEEC”) prescribes.

(g) The person executing the affidavit referenced in subsection (f) shall submit to the SEEC a list of Principals in accordance with the requirements set forth on a form that the

SEEC shall have prescribed for this purpose. The complete list of Principals shall be submitted to the SEEC at the same time that the affidavit is submitted to the State Agency, Quasi-public Agency or, in the case of a prequalification application, DAS. Notwithstanding any other provision in any applicable document or instrument, no party to the Contract, or a contract awarded pursuant to a non-competitive procurement, may begin performing in any way until the contracting State Agency or Quasi-public Agency has received the affidavit referenced in subsection (f) and the SEEC has received the Principals list.

(h) Notwithstanding any other provision in the Contract, invitation to bid, request for proposals and prequalification application:

(1) The State Contractor and Prospective State Contractor shall report to the SEEC, on a form which the SEEC prescribes, any changes in Principals occurring from and after the date of the previous Principals list by submitting and delivering such form to the SEEC no later than the fifteenth day of each month following the month when a change in Principals occurs, or the next succeeding business day, whichever is later. If the Contractor or Prospective State Contractor fail to submit and deliver the appropriately completed form by its due date, then the SEEC shall notify the State Agency or Quasi-public Agency and the Contractor of the failure in writing. The State Agency or Quasi-public Agency shall then review all relevant information and determine whether such failure constitutes a breach of this Contract. If the State Agency or Quasi-public Agency determines that a breach of this Contract has occurred, then the State Agency or Quasi-public Agency shall deliver a notice of breach to the Contractor, affording the Contractor an opportunity to cure the breach within ten (10) days from the date that the Contractor receives the notice. The State Agency or Quasi-public Agency may extend the right to cure period if, and continuing so long as, the State Agency or Quasi-public Agency is satisfied that the Contractor is making a good faith effort to cure the breach but the nature of the breach is such that it cannot be cured within the right to cure period. The SEEC may, if it deems it to be appropriate, send to the Contractor electronic reminders of the Contractor's obligation to report changes in Principals. The undertaking of this reminder is permissive and shall not be construed to be a condition precedent to the Contractor's obligation to submit and deliver the form timely.

(2) If the State Agency or Quasi-public Agency determines that the Contractor has breached the Contract by failing to comply with the requirements of this CCR provision, then the State Agency or Quasi-public Agency may, after expiration of the right to cure period, direct all appropriate State entities using the Contract to withhold any payment, in whole or in part, that may be due and owing to the Contractor under this Contract until such time as the Contractor submits and delivers an appropriately completed form to the SEEC.

(3) If the Contractor fails to submit and deliver the Principals list form timely three times in any 12-month period, then the SEEC may recommend to the State Agency or Quasi-public Agency that it take these failures into account for purposes of evaluating

the Contractor's responsibility in future procurements. The SEEC may recommend that the State Agency or Quasi-public Agency make a determination that the Contractor is not responsible.

(4) The Contractor's failure to submit and deliver the Principals list form timely for the third time in any 12-month period shall, upon the SEEC's recommendation, entitle the State Agency or Quasi-public Agency to Cancel the Contract. Accordingly, the third notice of breach to the Contractor from the State Agency or Quasi-public Agency in any 12-month period may include an effective Contract Cancellation date, in which case no further action shall be required of any party to effect the Cancellation of the Contract as of the stated date. If the notice does not set forth an effective Contract Cancellation date, then the State Agency or Quasi-public Agency may Cancel the Contract by giving the Contractor no less than twenty four (24) hours' prior written notice.

(5) Noting the absence of the SEEC's signature on the Contract, the State Agency or Quasi-public Agency represents that the SEEC has previously agreed in writing to assume the rights and responsibilities attaching to the SEEC and set forth in this CCR section. The State Agency or Quasi-public Agency shall provide a copy of that document to the Contractor upon request.



## Notice to Executive Branch State Contractors and Prospective State Contractors of Campaign Contribution and Solicitation Limitations

This notice is provided under the authority of Connecticut General Statutes §9-612 (f) (2) and is for the purpose of informing state contractors and prospective state contractors of the following law (*italicized words are defined on the reverse side of this page*).

### CAMPAIGN CONTRIBUTION AND SOLICITATION LIMITATIONS

No *state contractor, prospective state contractor, principal of a state contractor or principal of a prospective state contractor*, with regard to a *state contract or state contract solicitation* with or from a state agency in the executive branch or a quasi-public agency or a holder, or principal of a holder, of a valid prequalification certificate, shall make a contribution to (i) an exploratory committee or candidate committee established by a candidate for nomination or election to the office of Governor, Lieutenant Governor, Attorney General, State Comptroller, Secretary of the State or State Treasurer, (ii) a political committee authorized to make contributions or expenditures to or for the benefit of such candidates, or (iii) a party committee (which includes town committees).

In addition, no holder or principal of a holder of a valid prequalification certificate, shall make a contribution to (i) an exploratory committee or candidate committee established by a candidate for nomination or election to the office of State senator or State representative, (ii) a political committee authorized to make contributions or expenditures to or for the benefit of such candidates, or (iii) a party committee.

On and after January 1, 2011, no state contractor, prospective state contractor, principal of a state contractor or principal of a prospective state contractor, with regard to a state contract or state contract solicitation with or from a state agency in the executive branch or a quasi-public agency or a holder, or principal of a holder of a valid prequalification certificate, shall **knowingly solicit** contributions from the state contractor's or prospective state contractor's employees or from a *subcontractor or principals of the subcontractor* on behalf of (i) an exploratory committee or candidate committee established by a candidate for nomination or election to the office of Governor, Lieutenant Governor, Attorney General, State Comptroller, Secretary of the State or State Treasurer, (ii) a political committee authorized to make contributions or expenditures to or for the benefit of such candidates, or (iii) a party committee.

### DUTY TO INFORM

State contractors and prospective state contractors are required to inform their principals of the above prohibitions, as applicable, and the possible penalties and other consequences of any violation thereof.

### PENALTIES FOR VIOLATIONS

Contributions or solicitations of contributions made in violation of the above prohibitions may result in the following civil and criminal penalties:

**Civil penalties**—Up to \$2,000 or twice the amount of the prohibited contribution, whichever is greater, against a principal or a contractor. Any state contractor or prospective state contractor which fails to make reasonable efforts to comply with the provisions requiring notice to its principals of these prohibitions and the possible consequences of their violations may also be subject to civil penalties of up to \$2,000 or twice the amount of the prohibited contributions made by their principals.

**Criminal penalties**—Any knowing and willful violation of the prohibition is a Class D felony, which may subject the violator to imprisonment of not more than 5 years, or not more than \$5,000 in fines, or both.

### CONTRACT CONSEQUENCES

In the case of a state contractor, contributions made or solicited in violation of the above prohibitions may result in the contract being voided.

In the case of a prospective state contractor, contributions made or solicited in violation of the above prohibitions shall result in the contract described in the state contract solicitation not being awarded to the prospective state contractor, unless the State Elections Enforcement Commission determines that mitigating circumstances exist concerning such violation.

The State shall not award any other state contract to anyone found in violation of the above prohibitions for a period of one year after the election for which such contribution is made or solicited, unless the State Elections Enforcement Commission determines that mitigating circumstances exist concerning such violation.

Additional information may be found on the website of the State Elections Enforcement Commission, [www.ct.gov/seec](http://www.ct.gov/seec). Click on the link to "Lobbyist/Contractor Limitations."



## DEFINITIONS

"State contractor" means a person, business entity or nonprofit organization that enters into a state contract. Such person, business entity or nonprofit organization shall be deemed to be a state contractor until December thirty-first of the year in which such contract terminates. "State contractor" does not include a municipality or any other political subdivision of the state, including any entities or associations duly created by the municipality or political subdivision exclusively amongst themselves to further any purpose authorized by statute or charter, or an employee in the executive or legislative branch of state government or a quasi-public agency, whether in the classified or unclassified service and full or part-time, and only in such person's capacity as a state or quasi-public agency employee.

"Prospective state contractor" means a person, business entity or nonprofit organization that (i) submits a response to a state contract solicitation by the state, a state agency or a quasi-public agency, or a proposal in response to a request for proposals by the state, a state agency or a quasi-public agency, until the contract has been entered into, or (ii) holds a valid prequalification certificate issued by the Commissioner of Administrative Services under section 4a-100. "Prospective state contractor" does not include a municipality or any other political subdivision of the state, including any entities or associations duly created by the municipality or political subdivision exclusively amongst themselves to further any purpose authorized by statute or charter, or an employee in the executive or legislative branch of state government or a quasi-public agency, whether in the classified or unclassified service and full or part-time, and only in such person's capacity as a state or quasi-public agency employee.

"Principal of a state contractor or prospective state contractor" means (i) any individual who is a member of the board of directors of, or has an ownership interest of five per cent or more in, a state contractor or prospective state contractor, which is a business entity, except for an individual who is a member of the board of directors of a nonprofit organization, (ii) an individual who is employed by a state contractor or prospective state contractor, which is a business entity, as president, treasurer or executive vice president, (iii) an individual who is the chief executive officer of a state contractor or prospective state contractor, which is not a business entity, or if a state contractor or prospective state contractor has no such officer, then the officer who duly possesses comparable powers and duties, (iv) an officer or an employee of any state contractor or prospective state contractor who has *managerial or discretionary responsibilities with respect to a state contract*, (v) the spouse or a *dependent child* who is eighteen years of age or older of an individual described in this subparagraph, or (vi) a political committee established or controlled by an individual described in this subparagraph or the business entity or nonprofit organization that is the state contractor or prospective state contractor.

"State contract" means an agreement or contract with the state or any state agency or any quasi-public agency, let through a procurement process or otherwise, having a value of fifty thousand dollars or more, or a combination or series of such agreements or contracts having a value of one hundred thousand dollars or more in a calendar year, for (i) the rendition of services, (ii) the furnishing of any goods, material, supplies, equipment or any items of any kind, (iii) the construction, alteration or repair of any public building or public work, (iv) the acquisition, sale or lease of any land or building, (v) a licensing arrangement, or (vi) a grant, loan or loan guarantee. "State contract" does not include any agreement or contract with the state, any state agency or any quasi-public agency that is exclusively federally funded, an education loan, a loan to an individual for other than commercial purposes or any agreement or contract between the state or any state agency and the United States Department of the Navy or the United States Department of Defense.

"State contract solicitation" means a request by a state agency or quasi-public agency, in whatever form issued, including, but not limited to, an invitation to bid, request for proposals, request for information or request for quotes, inviting bids, quotes or other types of submittals, through a competitive procurement process or another process authorized by law waiving competitive procurement.

"Managerial or discretionary responsibilities with respect to a state contract" means having direct, extensive and substantive responsibilities with respect to the negotiation of the state contract and not peripheral, clerical or ministerial responsibilities.

"Dependent child" means a child residing in an individual's household who may legally be claimed as a dependent on the federal income tax of such individual.

"Solicit" means (A) requesting that a contribution be made, (B) participating in any fundraising activities for a candidate committee, exploratory committee, political committee or party committee, including, but not limited to, forwarding tickets to potential contributors, receiving contributions for transmission to any such committee, serving on the committee that is hosting a fundraising event, introducing the candidate or making other public remarks at a fundraising event, being honored or otherwise recognized at a fundraising event, or bundling contributions, (C) serving as chairperson, treasurer or deputy treasurer of any such committee, or (D) establishing a political committee for the sole purpose of soliciting or receiving contributions for any committee. Solicit does not include: (i) making a contribution that is otherwise permitted by Chapter 155 of the Connecticut General Statutes; (ii) informing any person of a position taken by a candidate for public office or a public official, (iii) notifying the person of any activities of, or contact information for, any candidate for public office; or (iv) serving as a member in any party committee or as an officer of such committee that is not otherwise prohibited in this section.

"Subcontractor" means any person, business entity or nonprofit organization that contracts to perform part or all of the obligations of a state contractor's state contract. Such person, business entity or nonprofit organization shall be deemed to be a subcontractor until December thirty first of the year in which the subcontract terminates. "Subcontractor" does not include (i) a municipality or any other political subdivision of the state, including any entities or associations duly created by the municipality or political subdivision exclusively amongst themselves to further any purpose authorized by statute or charter, or (ii) an employee in the executive or legislative branch of state government or a quasi-public agency, whether in the classified or unclassified service and full or part-time, and only in such person's capacity as a state or quasi-public agency employee.

"Principal of a subcontractor" means (i) any individual who is a member of the board of directors of, or has an ownership interest of five per cent or more in, a subcontractor, which is a business entity, except for an individual who is a member of the board of directors of a nonprofit organization, (ii) an individual who is employed by a subcontractor, which is a business entity, as president, treasurer or executive vice president, (iii) an individual who is the chief executive officer of a subcontractor, which is not a business entity, or if a subcontractor has no such officer, then the officer who duly possesses comparable powers and duties, (iv) an officer or an employee of any subcontractor who has managerial or discretionary responsibilities with respect to a subcontract with a state contractor, (v) the spouse or a dependent child who is eighteen years of age or older of an individual described in this subparagraph, or (vi) a political committee established or controlled by an individual described in this subparagraph or the business entity or nonprofit organization that is the subcontractor.



STATE OF CONNECTICUT
CONSULTING AGREEMENT AFFIDAVIT

Affidavit to accompany a bid or proposal for the purchase of goods and services with a value of \$50,000 or more in a calendar or fiscal year, pursuant to Connecticut General Statutes §§ 4a-81(a) and 4a-81(b). For sole source or no bid contracts the form is submitted at time of contract execution.

INSTRUCTIONS:

If the bidder or vendor has entered into a consulting agreement, as defined by Connecticut General Statutes § 4a-81(b)(1): Complete all sections of the form. If the bidder or contractor has entered into more than one such consulting agreement, use a separate form for each agreement. Sign and date the form in the presence of a Commissioner of the Superior Court or Notary Public. If the bidder or contractor has not entered into a consulting agreement, as defined by Connecticut General Statutes § 4a-81(b)(1): Complete only the shaded section of the form. Sign and date the form in the presence of a Commissioner of the Superior Court or Notary Public.

Submit completed form to the awarding State agency with bid or proposal. For a sole source award, submit completed form to the awarding State agency at the time of contract execution.

This affidavit must be amended if there is any change in the information contained in the most recently filed affidavit not later than (i) thirty days after the effective date of any such change or (ii) upon the submittal of any new bid or proposal, whichever is earlier.

AFFIDAVIT: [Number of Affidavits Sworn and Subscribed On This Day: \_\_\_\_\_]

I, the undersigned, hereby swear that I am a principal or key personnel of the bidder or contractor awarded a contract, as described in Connecticut General Statutes § 4a-81(b), or that I am the individual awarded such a contract who is authorized to execute such contract. I further swear that I have not entered into any consulting agreement in connection with such contract, except for the agreement listed below:

Form with fields for Consultant's Name and Title, Name of Firm (if applicable), Start Date, End Date, Cost, and Description of Services Provided.

Is the consultant a former State employee or former public official? [ ] YES [ ] NO

If YES: Name of Former State Agency, Termination Date of Employment

Sworn as true to the best of my knowledge and belief, subject to the penalties of false statement. Shaded area with fields for Printed Name of Bidder or Contractor, Signature of Principal or Key Personnel, Date, Printed Name (of above), and Awarding State Agency.

Sworn and subscribed before me on this \_\_\_\_\_ day of \_\_\_\_\_, 20\_\_\_\_.

Commissioner of the Superior Court or Notary Public

My Commission Expires

## **Non-discrimination.**

- (a) For purposes of this Section, the following terms are defined as follows:
- (1) “Commission” means the Commission on Human Rights and Opportunities;
  - (2) “Contract” and “contract” include any extension or modification of the Contract or contract;
  - (3) “Contractor” and “contractor” include any successors or assigns of the Contractor or contractor;
  - (4) “Gender identity or expression” means a person’s gender-related identity, appearance or behavior, whether or not that gender-related identity, appearance or behavior is different from that traditionally associated with the person’s physiology or assigned sex at birth, which gender-related identity can be shown by providing evidence including, but not limited to, medical history, care or treatment of the gender-related identity, consistent and uniform assertion of the gender-related identity or any other evidence that the gender-related identity is sincerely held, part of a person’s core identity or not being asserted for an improper purpose.
  - (5) “good faith” means that degree of diligence which a reasonable person would exercise in the performance of legal duties and obligations;
  - (6) “good faith efforts” shall include, but not be limited to, those reasonable initial efforts necessary to comply with statutory or regulatory requirements and additional or substituted efforts when it is determined that such initial efforts will not be sufficient to comply with such requirements;
  - (7) “marital status” means being single, married as recognized by the State of Connecticut, widowed, separated or divorced;
  - (8) “mental disability” means one or more mental disorders, as defined in the most recent edition of the American Psychiatric Association’s “Diagnostic and Statistical Manual of Mental Disorders”, or a record of or regarding a person as having one or more such disorders;
  - (9) “minority business enterprise” means any small contractor or supplier of materials fifty-one percent or more of the capital stock, if any, or assets of which is owned by a person or persons: (1) who are active in the daily affairs of the enterprise, (2) who have the power to direct the management and policies of the enterprise, and (3) who are members of a minority, as such term is defined in subsection (a) of C.G.S. § 32-9n; and
  - (10) “public works contract” means any agreement between any individual, firm or corporation and the State or any political subdivision of the State other than a municipality for construction, rehabilitation, conversion, extension, demolition or repair of a public building, highway or other changes or improvements in real property, or which is financed in whole or in part by the State, including, but not limited to, matching expenditures, grants, loans, insurance or guarantees.

For purposes of this Section, the terms “Contract” and “contract” do not include a contract where each contractor is (1) a political subdivision of the state, including, but not limited to, a municipality, unless the contract is a municipal public works contract or quasi-public agency project contract, (2) any other state, including but not limited to any federally recognized Indian tribal governments, as defined in C.G.S. § 1-267, (3) the federal government, (4) a foreign government, or (5) an agency of a subdivision, state or government described in the immediately preceding enumerated items (1), (2), (3), or (4).

- (b) (1) The Contractor agrees and warrants that in the performance of the Contract such Contractor will not discriminate or permit discrimination against any person or group of persons on the

grounds of race, color, religious creed, age, marital status, national origin, ancestry, sex, gender identity or expression, status as a veteran, intellectual disability, mental disability or physical disability, including, but not limited to, blindness, unless it is shown by such Contractor that such disability prevents performance of the work involved, in any manner prohibited by the laws of the United States or of the State of Connecticut; and the Contractor further agrees to take affirmative action to ensure that applicants with job-related qualifications are employed and that employees are treated when employed without regard to their race, color, religious creed, age, marital status, national origin, ancestry, sex, gender identity or expression, status as a veteran, intellectual disability, mental disability or physical disability, including, but not limited to, blindness, unless it is shown by the Contractor that such disability prevents performance of the work involved; (2) the Contractor agrees, in all solicitations or advertisements for employees placed by or on behalf of the Contractor, to state that it is an “affirmative action-equal opportunity employer” in accordance with regulations adopted by the Commission; (3) the Contractor agrees to provide each labor union or representative of workers with which the Contractor has a collective bargaining Agreement or other contract or understanding and each vendor with which the Contractor has a contract or understanding, a notice to be provided by the Commission, advising the labor union or workers’ representative of the Contractor’s commitments under this section and to post copies of the notice in conspicuous places available to employees and applicants for employment; (4) the Contractor agrees to comply with each provision of this Section and C.G.S. §§ 46a-68e and 46a-68f and with each regulation or relevant order issued by said Commission pursuant to C.G.S. §§ 46a-56, 46a-68e, 46a-68f and 46a-86; and (5) the Contractor agrees to provide the Commission on Human Rights and Opportunities with such information requested by the Commission, and permit access to pertinent books, records and accounts, concerning the employment practices and procedures of the Contractor as relate to the provisions of this Section and C.G.S. § 46a-56. If the contract is a public works contract, municipal public works contract or contract for a quasi-public agency project, the Contractor agrees and warrants that he or she will make good faith efforts to employ minority business enterprises as subcontractors and suppliers of materials on such public works or quasi-public agency projects.

- (c) Determination of the Contractor’s good faith efforts shall include, but shall not be limited to, the following factors: The Contractor’s employment and subcontracting policies, patterns and practices; affirmative advertising, recruitment and training; technical assistance activities and such other reasonable activities or efforts as the Commission may prescribe that are designed to ensure the participation of minority business enterprises in public works projects.
- (d) The Contractor shall develop and maintain adequate documentation, in a manner prescribed by the Commission, of its good faith efforts.
- (e) The Contractor shall include the provisions of subsection (b) of this Section in every subcontract or purchase order entered into in order to fulfill any obligation of a contract with the State and in every subcontract entered into in order to fulfill any obligation of a municipal public works contract for a quasi-public agency project, and such provisions shall be binding on a subcontractor, vendor or manufacturer unless exempted by regulations or orders of the Commission. The Contractor shall take such action with respect to any such subcontract or purchase order as the Commission may direct as a means of enforcing such provisions including sanctions for noncompliance in accordance with C.G.S. § 46a-56, as amended; provided if such Contractor becomes involved in, or is threatened with, litigation with a subcontractor or vendor as a result of such direction by the Commission regarding a State contract, the Contractor may request the State of Connecticut to enter into any such litigation or negotiation prior thereto to protect the interests of the State and the State may so enter.

- (f) The Contractor agrees to comply with the regulations referred to in this Section as they exist on the date of this Contract and as they may be adopted or amended from time to time during the term of this Contract and any amendments thereto.
- (g) (1) The Contractor agrees and warrants that in the performance of the Contract such Contractor will not discriminate or permit discrimination against any person or group of persons on the grounds of sexual orientation, in any manner prohibited by the laws of the United States or the State of Connecticut, and that employees are treated when employed without regard to their sexual orientation; (2) the Contractor agrees to provide each labor union or representative of workers with which such Contractor has a collective bargaining Agreement or other contract or understanding and each vendor with which such Contractor has a contract or understanding, a notice to be provided by the Commission on Human Rights and Opportunities advising the labor union or workers' representative of the Contractor's commitments under this section, and to post copies of the notice in conspicuous places available to employees and applicants for employment; (3) the Contractor agrees to comply with each provision of this section and with each regulation or relevant order issued by said Commission pursuant to C.G.S. § 46a-56; and (4) the Contractor agrees to provide the Commission on Human Rights and Opportunities with such information requested by the Commission, and permit access to pertinent books, records and accounts, concerning the employment practices and procedures of the Contractor which relate to the provisions of this Section and C.G.S. § 46a-56.
- (h) The Contractor shall include the provisions of the foregoing paragraph in every subcontract or purchase order entered into in order to fulfill any obligation of a contract with the State and such provisions shall be binding on a subcontractor, vendor or manufacturer unless exempted by regulations or orders of the Commission. The Contractor shall take such action with respect to any such subcontract or purchase order as the Commission may direct as a means of enforcing such provisions including sanctions for noncompliance in accordance with C.G.S. § 46a-56 as amended; provided, if such Contractor becomes involved in, or is threatened with, litigation with a subcontractor or vendor as a result of such direction by the Commission regarding a State contract, the Contractor may request the State of Connecticut to enter into any such litigation or negotiation prior thereto to protect the interests of the State and the State may so enter.

# Office of Policy and Management

REQUIRED FOR ALL CONTRACT TYPES

## Nondiscrimination Certification

Effective Date: June 30, 2009



Form A Representation By Individual



Form D New Resolution By Entity



Form B Representation By Entity



Form E Prior Resolution By Entity



Form C Affidavit By Entity

### DESCRIPTION

The Office of the Attorney General has approved the above nondiscrimination certification forms to assist executive branch agencies in complying with the State's contracting requirements under Connecticut General Statutes §§ 4a-60(a)(1) and 4a-60a(a)(1), as amended.

By law, a contractor must provide an awarding State agency with *written representation or documentation* that certifies the contractor complies with the State's nondiscrimination agreements and warranties.

***A nondiscrimination certification is required for all State contracts – regardless of type, term, cost, or value. The appropriate form must be submitted to the awarding State agency prior to contract execution. \*\*See list of exempt entities (below).\*\****

### FORMS & DESCRIPTIONS

There are five different certification forms. Form A is *always* used for contracts with an individual who is not an entity, regardless of the contract value. Form B is *always* used for contracts with an entity when the contract value is less than \$50,000. Form C is *recommended* for contracts valued at \$50,000 or more with an entity. If Form C is not used, either Form D or E must be used; both require a resolution (new or prior).

<b>For Use By:</b>	Value <b>Less Than \$50,000</b>	Value <b>\$50,000 or More</b>
<b>Individual</b>	<b>Form A</b> <i>Representation</i>	
<b>Entity</b>	<b>Form B</b> <i>Representation</i>	<b>Form C</b> <i>Affidavit</i>
		<b>Form D</b> <i>New Resolution</i>
		<b>Form E</b> <i>Prior Resolution</i>

#### Definitions

- *individual*: a person who is not an entity
- *entity*: corporation, limited liability company, or partnership

## EXPLANATION OF FORMS

**Form A. Representation:** For use by an individual when entering into any contract, regardless of contract value.

**Form B. Representation:** For use by an entity when entering into any contract valued at less than \$50,000 for any year of the contract.

**Form C. Affidavit:** (Recommended) For use by an entity when entering into any contract valued at \$50,000 or more for any year of the contract **and** the entity certifies through an affidavit that a complying nondiscrimination policy is currently in place.

**Form D. New Resolution:** For use by a entity when entering into any contract valued at \$50,000 or more for any year of the contract **and** the entity has a complying nondiscrimination policy adopted by a new resolution of the board of directors, shareholders, managers, members, or other governing body.

**Form E. Prior Resolution:** For use by a entity when entering into any contract valued at \$50,000 or more for any year of the contract **and** the entity has a complying nondiscrimination policy adopted by a prior resolution of the board of directors, shareholders, managers, members, or other governing body.

## EXEMPTIONS

The entities listed below are exempt and, therefore, not required to submit a nondiscrimination certification form when entering into a contract with the State:

1. political subdivisions of the State of Connecticut, including, but not limited to municipalities;
2. quasi-public agencies, as defined in C.G.S. § 1-120;
3. other states of the United States, including, but not limited to, the District of Columbia, Puerto Rico, U.S. territories and possessions, and federally recognized Indian tribal governments, as defined in C.G.S. § 1-267;
4. the federal government;
5. foreign governments; and
6. an agency of a subdivision, agency, state or government listed in items 1-5.

---

## For Further Information, Contact:

Please direct any questions about the nondiscrimination certification forms to the Commission on Human Rights and Opportunities:

Tel. 860/ 541-3400  
Connecticut Toll Free Tel. 1-800/ 477-5737

Content Last Modified on 7/8/2009 1:37:34 PM





**STATE OF CONNECTICUT**  
**NONDISCRIMINATION CERTIFICATION – Representation**  
**By Entity**  
**For Contracts Valued at Less Than \$50,000**

*Written representation that complies with the nondiscrimination agreements and warranties under Connecticut General Statutes §§ 4a-60(a)(1) and 4a-60a(a)(1), as amended*

---

**INSTRUCTIONS:**

For use by an entity (corporation, limited liability company, or partnership) when entering into any contract type with the State of Connecticut valued at less than **\$50,000** for each year of the contract. Complete all sections of the form. Submit to the awarding State agency prior to contract execution.

**REPRESENTATION OF AN ENTITY:**

I, \_\_\_\_\_, \_\_\_\_\_, of \_\_\_\_\_,  
Authorized Signatory Title Name of Entity

an entity duly formed and existing under the laws of \_\_\_\_\_,  
Name of State or Commonwealth

represent that I am authorized to execute and deliver this representation on behalf of

\_\_\_\_\_ and that \_\_\_\_\_  
Name of Entity Name of Entity

has a policy in place that complies with the nondiscrimination agreements and warranties of Connecticut General Statutes §§ 4a-60(a)(1) and 4a-60a(a)(1), as amended.

\_\_\_\_\_  
Authorized Signatory Date

\_\_\_\_\_  
Printed Name





**STATE OF CONNECTICUT**  
**NONDISCRIMINATION CERTIFICATION – New Resolution**  
**By Entity**  
**For Contracts Valued at \$50,000 or More**

*Documentation in the form of a corporate, company, or partnership policy adopted by resolution of the board of directors, shareholders, managers, members or other governing body of a contractor that certifies the contractor complies with the nondiscrimination agreements and warranties under Connecticut General Statutes §§ 4a-60(a)(1) and 4a-60a(a)(1), as amended*

**INSTRUCTIONS:**

For use by an entity (corporation, limited liability company, or partnership) when entering into any contract type with the State of Connecticut valued at \$50,000 or more for any year of the contract. Complete all sections of the form. Submit to the awarding State agency prior to contract execution.

**CERTIFICATION OF RESOLUTION:**

I, \_\_\_\_\_, \_\_\_\_\_, of \_\_\_\_\_,  
Authorized Signatory Title Name of Entity

an entity duly formed and existing under the laws of \_\_\_\_\_,  
Name of State or Commonwealth

certify that the following is a true and correct copy of a resolution adopted on the \_\_\_\_ day of \_\_\_\_\_, 20\_\_\_\_ by the governing body of \_\_\_\_\_,  
Name of Entity

in accordance with all of its documents of governance and management and the laws of \_\_\_\_\_, and further certify that such resolution has not been modified  
Name of State or Commonwealth

or revoked, and is in full force and effect.

RESOLVED: That the policies of \_\_\_\_\_ comply with the  
Name of Entity  
nondiscrimination agreements and warranties of Connecticut General Statutes  
§§ 4a-60(a)(1) and 4a-60a(a)(1), as amended.

The undersigned has executed this certificate this \_\_\_\_ day of \_\_\_\_\_, 20\_\_\_\_.

\_\_\_\_\_  
Authorized Signatory Date

\_\_\_\_\_  
Printed Name



**STATE OF CONNECTICUT**  
**NONDISCRIMINATION CERTIFICATION – Prior Resolution**  
**By Entity**  
**For Contracts Valued at \$50,000 or More**

*Documentation in the form of a corporate, company, or partnership policy adopted by a prior resolution of the board of directors, shareholders, managers, members or other governing body of a contractor that certifies the contractor complies with the nondiscrimination agreements and warranties under Connecticut General Statutes §§ 4a-60(a)(1) and 4a-60a(a)(1), as amended*

**INSTRUCTIONS:**

For use by an entity (corporation, limited liability company, or partnership) when entering into any contract type with the State of Connecticut valued at \$50,000 or more for any year of the contract. Complete all sections of the form. Attach copy of previously adopted resolution (*State of CT, Nondiscrimination Certification, Form D: New Resolution*). Submit all documentation to the awarding State agency prior to contract execution.

**CERTIFICATION OF PRIOR RESOLUTION:**

I, the undersigned, am a duly authorized corporate officer or member of \_\_\_\_\_  
Name of Entity

I have reviewed the attached prior resolution. I certify that:

- (1) the attached prior resolution complies with the nondiscrimination agreements and warranties of Connecticut General Statutes §§ 4a-60(a)(1) and 4a-60a(a)(1), as amended; and
- (2) the prior resolution remains in full force and effect on the date this documentation is submitted to the awarding State agency.

\_\_\_\_\_  
Authorized Signatory

\_\_\_\_\_  
Title

\_\_\_\_\_  
Printed Name

\_\_\_\_\_  
Date

**RESERVED FOR STATE USE**

I, the undersigned head of the awarding State agency, or designee, certify that the attached prior resolution complies with the nondiscrimination agreements and warranties of Connecticut General Statutes §§ 4a-60(a)(1) and 4a-60a(a)(1), as amended.

\_\_\_\_\_  
Signature of Agency Head (or designee)

\_\_\_\_\_  
Date

\_\_\_\_\_  
Awarding State Agency





By signing the filled-out form, you:

1. Certify that the TIN you are giving is correct (or you are waiting for a number to be issued),
2. Certify that you are not subject to backup withholding, or
3. Claim exemption from backup withholding if you are a U.S. exempt payee. If applicable, you are also certifying that as a U.S. person, your allocable share of any partnership income from a U.S. trade or business is not subject to the withholding tax on foreign partners' share of effectively connected income, and
4. Certify that FATCA code(s) entered on this form (if any) indicating that you are exempt from the FATCA reporting, is correct. See *What is FATCA reporting*, later, for further information.

**Note:** If you are a U.S. person and a requester gives you a form other than Form W-9 to request your TIN, you must use the requester's form if it is substantially similar to this Form W-9.

**Definition of a U.S. person.** For federal tax purposes, you are considered a U.S. person if you are:

- An individual who is a U.S. citizen or U.S. resident alien;
- A partnership, corporation, company, or association created or organized in the United States or under the laws of the United States;
- An estate (other than a foreign estate); or
- A domestic trust (as defined in Regulations section 301.7701-7).

**Special rules for partnerships.** Partnerships that conduct a trade or business in the United States are generally required to pay a withholding tax under section 1446 on any foreign partners' share of effectively connected taxable income from such business. Further, in certain cases where a Form W-9 has not been received, the rules under section 1446 require a partnership to presume that a partner is a foreign person, and pay the section 1446 withholding tax. Therefore, if you are a U.S. person that is a partner in a partnership conducting a trade or business in the United States, provide Form W-9 to the partnership to establish your U.S. status and avoid section 1446 withholding on your share of partnership income.

In the cases below, the following person must give Form W-9 to the partnership for purposes of establishing its U.S. status and avoiding withholding on its allocable share of net income from the partnership conducting a trade or business in the United States.

- In the case of a disregarded entity with a U.S. owner, the U.S. owner of the disregarded entity and not the entity;
- In the case of a grantor trust with a U.S. grantor or other U.S. owner, generally, the U.S. grantor or other U.S. owner of the grantor trust and not the trust; and
- In the case of a U.S. trust (other than a grantor trust), the U.S. trust (other than a grantor trust) and not the beneficiaries of the trust.

**Foreign person.** If you are a foreign person or the U.S. branch of a foreign bank that has elected to be treated as a U.S. person, do not use Form W-9. Instead, use the appropriate Form W-8 or Form 8233 (see Pub. 515, *Withholding of Tax on Nonresident Aliens and Foreign Entities*).

**Nonresident alien who becomes a resident alien.** Generally, only a nonresident alien individual may use the terms of a tax treaty to reduce or eliminate U.S. tax on certain types of income. However, most tax treaties contain a provision known as a "saving clause." Exceptions specified in the saving clause may permit an exemption from tax to continue for certain types of income even after the payee has otherwise become a U.S. resident alien for tax purposes.

If you are a U.S. resident alien who is relying on an exception contained in the saving clause of a tax treaty to claim an exemption from U.S. tax on certain types of income, you must attach a statement to Form W-9 that specifies the following five items.

1. The treaty country. Generally, this must be the same treaty under which you claimed exemption from tax as a nonresident alien.
2. The treaty article addressing the income.
3. The article number (or location) in the tax treaty that contains the saving clause and its exceptions.
4. The type and amount of income that qualifies for the exemption from tax.
5. Sufficient facts to justify the exemption from tax under the terms of the treaty article.

**Example.** Article 20 of the U.S.-China income tax treaty allows an exemption from tax for scholarship income received by a Chinese student temporarily present in the United States. Under U.S. law, this student will become a resident alien for tax purposes if his or her stay in the United States exceeds 5 calendar years. However, paragraph 2 of the first Protocol to the U.S.-China treaty (dated April 30, 1984) allows the provisions of Article 20 to continue to apply even after the Chinese student becomes a resident alien of the United States. A Chinese student who qualifies for this exception (under paragraph 2 of the first protocol) and is relying on this exception to claim an exemption from tax on his or her scholarship or fellowship income would attach to Form W-9 a statement that includes the information described above to support that exemption.

If you are a nonresident alien or a foreign entity, give the requester the appropriate completed Form W-8 or Form 8233.

## Backup Withholding

**What is backup withholding?** Persons making certain payments to you must under certain conditions withhold and pay to the IRS 28% of such payments. This is called "backup withholding." Payments that may be subject to backup withholding include interest, tax-exempt interest, dividends, broker and barter exchange transactions, rents, royalties, nonemployee pay, payments made in settlement of payment card and third party network transactions, and certain payments from fishing boat operators. Real estate transactions are not subject to backup withholding.

You will not be subject to backup withholding on payments you receive if you give the requester your correct TIN, make the proper certifications, and report all your taxable interest and dividends on your tax return.

**Payments you receive will be subject to backup withholding if:**

1. You do not furnish your TIN to the requester,
2. You do not certify your TIN when required (see the instructions for Part II for details),
3. The IRS tells the requester that you furnished an incorrect TIN,
4. The IRS tells you that you are subject to backup withholding because you did not report all your interest and dividends on your tax return (for reportable interest and dividends only), or
5. You do not certify to the requester that you are not subject to backup withholding under 4 above (for reportable interest and dividend accounts opened after 1983 only).

Certain payees and payments are exempt from backup withholding. See *Exempt payee code*, later, and the separate Instructions for the Requester of Form W-9 for more information.

Also see *Special rules for partnerships*, earlier.

## What is FATCA Reporting?

The Foreign Account Tax Compliance Act (FATCA) requires a participating foreign financial institution to report all United States account holders that are specified United States persons. Certain payees are exempt from FATCA reporting. See *Exemption from FATCA reporting code*, later, and the Instructions for the Requester of Form W-9 for more information.

## Updating Your Information

You must provide updated information to any person to whom you claimed to be an exempt payee if you are no longer an exempt payee and anticipate receiving reportable payments in the future from this person. For example, you may need to provide updated information if you are a C corporation that elects to be an S corporation, or if you no longer are tax exempt. In addition, you must furnish a new Form W-9 if the name or TIN changes for the account; for example, if the grantor of a grantor trust dies.

## Penalties

**Failure to furnish TIN.** If you fail to furnish your correct TIN to a requester, you are subject to a penalty of \$50 for each such failure unless your failure is due to reasonable cause and not to willful neglect.

**Civil penalty for false information with respect to withholding.** If you make a false statement with no reasonable basis that results in no backup withholding, you are subject to a \$500 penalty.

**Criminal penalty for falsifying information.** Willfully falsifying certifications or affirmations may subject you to criminal penalties including fines and/or imprisonment.

**Misuse of TINs.** If the requester discloses or uses TINs in violation of federal law, the requester may be subject to civil and criminal penalties.

## Specific Instructions

### Line 1

You must enter one of the following on this line; **do not** leave this line blank. The name should match the name on your tax return.

If this Form W-9 is for a joint account (other than an account maintained by a foreign financial institution (FFI)), list first, and then circle, the name of the person or entity whose number you entered in Part I of Form W-9. If you are providing Form W-9 to an FFI to document a joint account, each holder of the account that is a U.S. person must provide a Form W-9.

a. **Individual.** Generally, enter the name shown on your tax return. If you have changed your last name without informing the Social Security Administration (SSA) of the name change, enter your first name, the last name as shown on your social security card, and your new last name.

**Note: ITIN applicant:** Enter your individual name as it was entered on your Form W-7 application, line 1a. This should also be the same as the name you entered on the Form 1040/1040A/1040EZ you filed with your application.

b. **Sole proprietor or single-member LLC.** Enter your individual name as shown on your 1040/1040A/1040EZ on line 1. You may enter your business, trade, or “doing business as” (DBA) name on line 2.

c. **Partnership, LLC that is not a single-member LLC, C corporation, or S corporation.** Enter the entity’s name as shown on the entity’s tax return on line 1 and any business, trade, or DBA name on line 2.

d. **Other entities.** Enter your name as shown on required U.S. federal tax documents on line 1. This name should match the name shown on the charter or other legal document creating the entity. You may enter any business, trade, or DBA name on line 2.

e. **Disregarded entity.** For U.S. federal tax purposes, an entity that is disregarded as an entity separate from its owner is treated as a “disregarded entity.” See Regulations section 301.7701-2(c)(2)(iii). Enter the owner’s name on line 1. The name of the entity entered on line 1 should never be a disregarded entity. The name on line 1 should be the name shown on the income tax return on which the income should be reported. For example, if a foreign LLC that is treated as a disregarded entity for U.S. federal tax purposes has a single owner that is a U.S. person, the U.S. owner’s name is required to be provided on line 1. If the direct owner of the entity is also a disregarded entity, enter the first owner that is not disregarded for federal tax purposes. Enter the disregarded entity’s name on line 2, “Business name/disregarded entity name.” If the owner of the disregarded entity is a foreign person, the owner must complete an appropriate Form W-8 instead of a Form W-9. This is the case even if the foreign person has a U.S. TIN.

### Line 2

If you have a business name, trade name, DBA name, or disregarded entity name, you may enter it on line 2.

### Line 3

Check the appropriate box on line 3 for the U.S. federal tax classification of the person whose name is entered on line 1. Check only one box on line 3.

IF the entity/person on line 1 is a(n) . . .	THEN check the box for . . .
• Corporation	Corporation
• Individual • Sole proprietorship, or • Single-member limited liability company (LLC) owned by an individual and disregarded for U.S. federal tax purposes.	Individual/sole proprietor or single-member LLC
• LLC treated as a partnership for U.S. federal tax purposes, • LLC that has filed Form 8832 or 2553 to be taxed as a corporation, or • LLC that is disregarded as an entity separate from its owner but the owner is another LLC that is not disregarded for U.S. federal tax purposes.	Limited liability company and enter the appropriate tax classification. (P= Partnership; C= C corporation; or S= S corporation)
• Partnership	Partnership
• Trust/estate	Trust/estate

### Line 4, Exemptions

If you are exempt from backup withholding and/or FATCA reporting, enter in the appropriate space on line 4 any code(s) that may apply to you.

#### Exempt payee code.

- Generally, individuals (including sole proprietors) are not exempt from backup withholding.
- Except as provided below, corporations are exempt from backup withholding for certain payments, including interest and dividends.
- Corporations are not exempt from backup withholding for payments made in settlement of payment card or third party network transactions.
- Corporations are not exempt from backup withholding with respect to attorneys’ fees or gross proceeds paid to attorneys, and corporations that provide medical or health care services are not exempt with respect to payments reportable on Form 1099-MISC.

The following codes identify payees that are exempt from backup withholding. Enter the appropriate code in the space in line 4.

- 1—An organization exempt from tax under section 501(a), any IRA, or a custodial account under section 403(b)(7) if the account satisfies the requirements of section 401(f)(2)
- 2—The United States or any of its agencies or instrumentalities
- 3—A state, the District of Columbia, a U.S. commonwealth or possession, or any of their political subdivisions or instrumentalities
- 4—A foreign government or any of its political subdivisions, agencies, or instrumentalities
- 5—A corporation
- 6—A dealer in securities or commodities required to register in the United States, the District of Columbia, or a U.S. commonwealth or possession
- 7—A futures commission merchant registered with the Commodity Futures Trading Commission
- 8—A real estate investment trust
- 9—An entity registered at all times during the tax year under the Investment Company Act of 1940
- 10—A common trust fund operated by a bank under section 584(a)
- 11—A financial institution
- 12—A middleman known in the investment community as a nominee or custodian
- 13—A trust exempt from tax under section 664 or described in section 4947

The following chart shows types of payments that may be exempt from backup withholding. The chart applies to the exempt payees listed above, 1 through 13.

IF the payment is for . . .	THEN the payment is exempt for . . .
Interest and dividend payments	All exempt payees except for 7
Broker transactions	Exempt payees 1 through 4 and 6 through 11 and all C corporations. S corporations must not enter an exempt payee code because they are exempt only for sales of noncovered securities acquired prior to 2012.
Barter exchange transactions and patronage dividends	Exempt payees 1 through 4
Payments over \$600 required to be reported and direct sales over \$5,000 <sup>1</sup>	Generally, exempt payees 1 through 5 <sup>2</sup>
Payments made in settlement of payment card or third party network transactions	Exempt payees 1 through 4

<sup>1</sup> See Form 1099-MISC, Miscellaneous Income, and its instructions.

<sup>2</sup> However, the following payments made to a corporation and reportable on Form 1099-MISC are not exempt from backup withholding: medical and health care payments, attorneys' fees, gross proceeds paid to an attorney reportable under section 6045(f), and payments for services paid by a federal executive agency.

**Exemption from FATCA reporting code.** The following codes identify payees that are exempt from reporting under FATCA. These codes apply to persons submitting this form for accounts maintained outside of the United States by certain foreign financial institutions. Therefore, if you are only submitting this form for an account you hold in the United States, you may leave this field blank. Consult with the person requesting this form if you are uncertain if the financial institution is subject to these requirements. A requester may indicate that a code is not required by providing you with a Form W-9 with "Not Applicable" (or any similar indication) written or printed on the line for a FATCA exemption code.

A—An organization exempt from tax under section 501(a) or any individual retirement plan as defined in section 7701(a)(37)

B—The United States or any of its agencies or instrumentalities

C—A state, the District of Columbia, a U.S. commonwealth or possession, or any of their political subdivisions or instrumentalities

D—A corporation the stock of which is regularly traded on one or more established securities markets, as described in Regulations section 1.1472-1(c)(1)(i)

E—A corporation that is a member of the same expanded affiliated group as a corporation described in Regulations section 1.1472-1(c)(1)(i)

F—A dealer in securities, commodities, or derivative financial instruments (including notional principal contracts, futures, forwards, and options) that is registered as such under the laws of the United States or any state

G—A real estate investment trust

H—A regulated investment company as defined in section 851 or an entity registered at all times during the tax year under the Investment Company Act of 1940

I—A common trust fund as defined in section 584(a)

J—A bank as defined in section 581

K—A broker

L—A trust exempt from tax under section 664 or described in section 4947(a)(1)

M—A tax exempt trust under a section 403(b) plan or section 457(g) plan

**Note:** You may wish to consult with the financial institution requesting this form to determine whether the FATCA code and/or exempt payee code should be completed.

## Line 5

Enter your address (number, street, and apartment or suite number). This is where the requester of this Form W-9 will mail your information returns. If this address differs from the one the requester already has on file, write NEW at the top. If a new address is provided, there is still a chance the old address will be used until the payor changes your address in their records.

## Line 6

Enter your city, state, and ZIP code.

## Part I. Taxpayer Identification Number (TIN)

**Enter your TIN in the appropriate box.** If you are a resident alien and you do not have and are not eligible to get an SSN, your TIN is your IRS individual taxpayer identification number (ITIN). Enter it in the social security number box. If you do not have an ITIN, see *How to get a TIN* below.

If you are a sole proprietor and you have an EIN, you may enter either your SSN or EIN.

If you are a single-member LLC that is disregarded as an entity separate from its owner, enter the owner's SSN (or EIN, if the owner has one). Do not enter the disregarded entity's EIN. If the LLC is classified as a corporation or partnership, enter the entity's EIN.

**Note:** See *What Name and Number To Give the Requester*, later, for further clarification of name and TIN combinations.

**How to get a TIN.** If you do not have a TIN, apply for one immediately. To apply for an SSN, get Form SS-5, Application for a Social Security Card, from your local SSA office or get this form online at [www.SSA.gov](http://www.SSA.gov). You may also get this form by calling 1-800-772-1213. Use Form W-7, Application for IRS Individual Taxpayer Identification Number, to apply for an ITIN, or Form SS-4, Application for Employer Identification Number, to apply for an EIN. You can apply for an EIN online by accessing the IRS website at [www.irs.gov/Businesses](http://www.irs.gov/Businesses) and clicking on Employer Identification Number (EIN) under Starting a Business. Go to [www.irs.gov/Forms](http://www.irs.gov/Forms) to view, download, or print Form W-7 and/or Form SS-4. Or, you can go to [www.irs.gov/OrderForms](http://www.irs.gov/OrderForms) to place an order and have Form W-7 and/or SS-4 mailed to you within 10 business days.

If you are asked to complete Form W-9 but do not have a TIN, apply for a TIN and write "Applied For" in the space for the TIN, sign and date the form, and give it to the requester. For interest and dividend payments, and certain payments made with respect to readily tradable instruments, generally you will have 60 days to get a TIN and give it to the requester before you are subject to backup withholding on payments. The 60-day rule does not apply to other types of payments. You will be subject to backup withholding on all such payments until you provide your TIN to the requester.

**Note:** Entering "Applied For" means that you have already applied for a TIN or that you intend to apply for one soon.

**Caution:** A disregarded U.S. entity that has a foreign owner must use the appropriate Form W-8.

## Part II. Certification

To establish to the withholding agent that you are a U.S. person, or resident alien, sign Form W-9. You may be requested to sign by the withholding agent even if item 1, 4, or 5 below indicates otherwise.

For a joint account, only the person whose TIN is shown in Part I should sign (when required). In the case of a disregarded entity, the person identified on line 1 must sign. Exempt payees, see *Exempt payee code*, earlier.

**Signature requirements.** Complete the certification as indicated in items 1 through 5 below.

**1. Interest, dividend, and barter exchange accounts opened before 1984 and broker accounts considered active during 1983.**

You must give your correct TIN, but you do not have to sign the certification.

**2. Interest, dividend, broker, and barter exchange accounts opened after 1983 and broker accounts considered inactive during 1983.**

You must sign the certification or backup withholding will apply. If you are subject to backup withholding and you are merely providing your correct TIN to the requester, you must cross out item 2 in the certification before signing the form.

**3. Real estate transactions.**

You must sign the certification. You may cross out item 2 of the certification.

**4. Other payments.** You must give your correct TIN, but you do not have to sign the certification unless you have been notified that you have previously given an incorrect TIN. "Other payments" include payments made in the course of the requester's trade or business for rents, royalties, goods (other than bills for merchandise), medical and health care services (including payments to corporations), payments to a nonemployee for services, payments made in settlement of payment card and third party network transactions, payments to certain fishing boat crew members and fishermen, and gross proceeds paid to attorneys (including payments to corporations).

**5. Mortgage interest paid by you, acquisition or abandonment of secured property, cancellation of debt, qualified tuition program payments (under section 529), ABLE accounts (under section 529A), IRA, Coverdell ESA, Archer MSA or HSA contributions or distributions, and pension distributions.** You must give your correct TIN, but you do not have to sign the certification.

**What Name and Number To Give the Requester**

For this type of account:	Give name and SSN of:
1. Individual	The individual
2. Two or more individuals (joint account) other than an account maintained by an FFI	The actual owner of the account or, if combined funds, the first individual on the account <sup>1</sup>
3. Two or more U.S. persons (joint account maintained by an FFI)	Each holder of the account
4. Custodial account of a minor (Uniform Gift to Minors Act)	The minor <sup>2</sup>
5. a. The usual revocable savings trust (grantor is also trustee)	The grantor-trustee <sup>1</sup>
b. So-called trust account that is not a legal or valid trust under state law	The actual owner <sup>1</sup>
6. Sole proprietorship or disregarded entity owned by an individual	The owner <sup>3</sup>
7. Grantor trust filing under Optional Form 1099 Filing Method 1 (see Regulations section 1.671-4(b)(2)(i)(A))	The grantor*
For this type of account:	Give name and EIN of:
8. Disregarded entity not owned by an individual	The owner
9. A valid trust, estate, or pension trust	Legal entity <sup>4</sup>
10. Corporation or LLC electing corporate status on Form 8832 or Form 2553	The corporation
11. Association, club, religious, charitable, educational, or other tax-exempt organization	The organization
12. Partnership or multi-member LLC	The partnership
13. A broker or registered nominee	The broker or nominee

For this type of account:	Give name and EIN of:
14. Account with the Department of Agriculture in the name of a public entity (such as a state or local government, school district, or prison) that receives agricultural program payments	The public entity
15. Grantor trust filing under the Form 1041 Filing Method or the Optional Form 1099 Filing Method 2 (see Regulations section 1.671-4(b)(2)(i)(B))	The trust

<sup>1</sup> List first and circle the name of the person whose number you furnish. If only one person on a joint account has an SSN, that person's number must be furnished.

<sup>2</sup> Circle the minor's name and furnish the minor's SSN.

<sup>3</sup> You must show your individual name and you may also enter your business or DBA name on the "Business name/disregarded entity" name line. You may use either your SSN or EIN (if you have one), but the IRS encourages you to use your SSN.

<sup>4</sup> List first and circle the name of the trust, estate, or pension trust. (Do not furnish the TIN of the personal representative or trustee unless the legal entity itself is not designated in the account title.) Also see *Special rules for partnerships*, earlier.

\*Note: The grantor also must provide a Form W-9 to trustee of trust.

Note: If no name is circled when more than one name is listed, the number will be considered to be that of the first name listed.

**Secure Your Tax Records From Identity Theft**

Identity theft occurs when someone uses your personal information such as your name, SSN, or other identifying information, without your permission, to commit fraud or other crimes. An identity thief may use your SSN to get a job or may file a tax return using your SSN to receive a refund.

To reduce your risk:

- Protect your SSN,
- Ensure your employer is protecting your SSN, and
- Be careful when choosing a tax preparer.

If your tax records are affected by identity theft and you receive a notice from the IRS, respond right away to the name and phone number printed on the IRS notice or letter.

If your tax records are not currently affected by identity theft but you think you are at risk due to a lost or stolen purse or wallet, questionable credit card activity or credit report, contact the IRS Identity Theft Hotline at 1-800-908-4490 or submit Form 14039.

For more information, see Pub. 5027, Identity Theft Information for Taxpayers.

Victims of identity theft who are experiencing economic harm or a systemic problem, or are seeking help in resolving tax problems that have not been resolved through normal channels, may be eligible for Taxpayer Advocate Service (TAS) assistance. You can reach TAS by calling the TAS toll-free case intake line at 1-877-777-4778 or TTY/TDD 1-800-829-4059.

**Protect yourself from suspicious emails or phishing schemes.**

Phishing is the creation and use of email and websites designed to mimic legitimate business emails and websites. The most common act is sending an email to a user falsely claiming to be an established legitimate enterprise in an attempt to scam the user into surrendering private information that will be used for identity theft.

The IRS does not initiate contacts with taxpayers via emails. Also, the IRS does not request personal detailed information through email or ask taxpayers for the PIN numbers, passwords, or similar secret access information for their credit card, bank, or other financial accounts.

If you receive an unsolicited email claiming to be from the IRS, forward this message to [phishing@irs.gov](mailto:phishing@irs.gov). You may also report misuse of the IRS name, logo, or other IRS property to the Treasury Inspector General for Tax Administration (TIGTA) at 1-800-366-4484. You can forward suspicious emails to the Federal Trade Commission at [spam@uce.gov](mailto:spam@uce.gov) or report them at [www.ftc.gov/complaint](http://www.ftc.gov/complaint). You can contact the FTC at [www.ftc.gov/idtheft](http://www.ftc.gov/idtheft) or 877-IDTHEFT (877-438-4338). If you have been the victim of identity theft, see [www.IdentityTheft.gov](http://www.IdentityTheft.gov) and Pub. 5027.

Visit [www.irs.gov/IdentityTheft](http://www.irs.gov/IdentityTheft) to learn more about identity theft and how to reduce your risk.

## Privacy Act Notice

Section 6109 of the Internal Revenue Code requires you to provide your correct TIN to persons (including federal agencies) who are required to file information returns with the IRS to report interest, dividends, or certain other income paid to you; mortgage interest you paid; the acquisition or abandonment of secured property; the cancellation of debt; or contributions you made to an IRA, Archer MSA, or HSA. The person collecting this form uses the information on the form to file information returns with the IRS, reporting the above information. Routine uses of this information include giving it to the Department of Justice for civil and criminal litigation and to cities, states, the District of Columbia, and U.S. commonwealths and possessions for use in administering their laws. The information also may be disclosed to other countries under a treaty, to federal and state agencies to enforce civil and criminal laws, or to federal law enforcement and intelligence agencies to combat terrorism. You must provide your TIN whether or not you are required to file a tax return. Under section 3406, payers must generally withhold a percentage of taxable interest, dividend, and certain other payments to a payee who does not give a TIN to the payer. Certain penalties may also apply for providing false or fraudulent information.



EASTERN CONNECTICUT STATE UNIVERSITY

83 WINDHAM STREET • WILLIMANTIC, CONNECTICUT 06226 • 860-465-5000

## **INSPECTION OF PROPOSALS AND CONFIDENTIAL INFORMATION**

Proposals may be available for public inspection upon notice of award and shall be available for public inspection after the contract is signed by all parties. Information marked as “confidential” in any proposal shall be honored as such, to the extent allowable under the Freedom of Information Act.

The University treats Proposals as confidential until after the award is issued. At that time they become subject to disclosure under the Freedom of Information Act. If a respondent wishes to supply any information, which it believes is exempt from disclosure under the Act that respondent should summarize such information in a separate envelope and each page submitted should clearly state “Confidential”, but otherwise be presented in the same manner as the Proposal. However, any such information is provided entirely at the respondent’s own risk and the University assumes no liability for any loss or damage which may result from the University’s disclosure at any time of any information provided by the respondent in connection with its proposal.

# Connecticut State University System



**Central Connecticut State University  
Eastern Connecticut State University  
Southern Connecticut State University  
Western Connecticut State University  
System Office**

## STANDARD TERMS AND CONDITIONS

### I. DEFINITIONS

The following words, when used herein, shall have the following meanings:

1. "Contract" shall mean any agreement negotiated by and between CSU and the contractor selected by CSU as the result of a request for proposal, request for quotation, or request for bid, including, but not limited to, a personal service agreement or purchase order.
2. "CSU" shall refer to the Connecticut State University System, which is comprised of Central Connecticut State University, Eastern Connecticut State University, Southern Connecticut State University, Western Connecticut State University and the System Office, collectively and individually, as the context requires.
3. "Person" shall mean an individual, partnership, corporation or other business entity, as the context requires.
4. "Proposal" shall mean a response to a request for proposal, request for bid, or request for quotation.
5. "Proposer" shall mean a contractor that submits a response to a request for proposal, request for bid, or request for quotation.
6. "RFP" shall mean a request or invitation for proposal, bid, or quotation, as applicable.

### II. TERMS AND CONDITIONS RELATED TO REQUESTS FOR PROPOSALS

#### A. General Conditions

1. CSU reserves the right to amend or cancel an RFP prior to the date and time for the opening of proposals. CSU, in its sole discretion, reserves the right to accept or reject any and all proposals, in whole or in part, and to waive any technicality in any proposal submitted, and to accept any part of a proposal deemed to be in the best interest of CSU.
2. Proposals received from proposers debarred by the State of Connecticut will not be considered for award.
3. CSU does not commit to specific volumes of activity, nor does it guarantee the accuracy of statistical information provided in the RFP. Such information is supplied to proposers for reference only.
4. All responses to the RFP shall be and remain the sole property of CSU.
5. Each proposer shall bear all costs associated with proposer's response to an RFP, including, but not limited to, the costs of any presentation and/or demonstration required by CSU. In addition, answers or clarifications sought by CSU arising out of or in connection with the proposal shall be furnished by the proposer at the proposer's expense.

6. CSU reserves the right to negotiate, as it may deem necessary, with any or all of the proposers that submit proposals.
7. Any alleged oral agreement or arrangement made by any proposer with CSU or any employee thereof shall not be binding.

#### B. Submission of Proposals

1. Proposals must be submitted on forms supplied by CSU. Telephone, facsimile, or email proposals will not be accepted in response to an RFP.
2. The time and date proposals are to be received and opened are stated in each RFP issued by CSU. Proposals received in the applicable CSU purchasing department after the date and time specified in the RFP will be returned to the proposer unopened. Proposal amendments received by CSU after the time specified for opening of proposals shall not be considered.
3. All proposals must be addressed to the location designated in the RFP. Proposal envelopes must clearly state the proposal number as well as the date and time of the opening of the proposals, as stated in the RFP. The name and address of the proposer must appear in the upper left hand corner of the envelope.
4. Proposals must be computer prepared, typewritten or handwritten in ink. Proposals submitted in pencil will be rejected.
5. Proposers must answer all the questions set forth in the RFP using the outline and numbering scheme set forth therein. Proposers must furnish all information requested in the RFP and supply all materials required for consideration. Failure of the proposer to answer all questions and supply all information and materials requested may be grounds for rejection of the proposal.
6. All proposals must be signed by a person duly authorized to sign proposals on behalf of the proposer. All signatures on the proposal must be original. Proposals bearing stamp signatures will be rejected. Unsigned proposals will be rejected.
7. Alterations or corrections to the proposal must be initialed by the person signing the proposal or his or her authorized designee. All initials on alterations or corrections to the proposal must be original. In the event that an authorized designee initials an alteration or correction, the proposer must submit a written authorization from the proposal's signatory to the authorized designee, authorizing the designee to make the alteration or correction. Failure to submit such an authorization shall result in rejection of proposal as to those items altered or corrected and not initialed.

8. Conditional proposals are subject to rejection in whole or in part, in the sole discretion of CSU. A conditional proposal is defined as one that limits, modifies, expands or supplements any of the terms and conditions and/or specifications of the RFP.
9. Alternate proposals will not be considered by CSU, unless otherwise noted on the RFP or on the proposal form. An alternate proposal is defined as one that is submitted in addition to the proposer's primary response to the RFP.
10. CSU does not sponsor any one manufacturer's products, but lists equipment by name and model number to designate the quality and performance level desired. Proposers may propose substitutes similar in nature to the equipment specified. The substitute must, in the sole determination of CSU, be equal in quality, durability, appearance, strength and design to the equipment or product specified in the RFP, or offer a clear advantage to CSU because of improved or superior performance. All proposals including equipment or product substitutes must be accompanied with current descriptive literature on, and data substantiating, the equal or superior nature of the substitute. All final decisions concerning substitutes will be made by CSU prior to any award. The word substitute shall not be construed to permit substantial departure from the detailed requirements of the specifications.
11. Each proposer's prices must be firm for a period up to 120 days from date of the opening of proposals. Prices must be extended in decimal, not fraction, must be net, and must include transportation and delivery charges, fully prepaid by the contractor, to the destination specified in the proposal, and subject only to cash discount.
12. Pursuant to Section 12-412 of the Connecticut General Statutes, the State of Connecticut is exempt from the payment of excise, transportation and sales taxes imposed by the Federal Government and/or the State. Accordingly, such taxes must not be included in proposal prices.
13. If there is a discrepancy between a unit price and an extended price, the unit price will govern.
14. By submitting a proposal, the proposer asserts that the offer and information contained therein is in all respects fair and without collusion or fraud and was not made in connection with any competing proposer's submission of a separate response to the RFP. By submitting a proposal, the proposer further asserts that it neither participated in the formation of CSU's solicitation development process nor had any knowledge of the specific contents of the RFP prior to its issuance, and that no employee of CSU participated directly or indirectly in the preparation of the proposer's proposal.
15. It is the proposer's responsibility to check the website of the State of Connecticut Department of Administrative Services ([www.das.state.ct.us/Purchase/Portal/Portal\\_Home.asp](http://www.das.state.ct.us/Purchase/Portal/Portal_Home.asp)) for changes prior to the proposal opening. It is the responsibility of the proposer to obtain all information related to proposal submission including, without limitation, any and all addenda or supplements required.
16. Any person contemplating submitting a proposal who is in doubt as to the true meaning of, or is in need of clarification of, any part of the RFP or the specifications set forth therein, must submit a written request for clarification to CSU. The proposer may rely only upon a response to a request for clarification set forth in writing by CSU.
17. Proposals for the provision of services must include the cost of obtaining all permits, licenses, and notices

required by the city or town in which the services is to be provided, and the State and Federal governments..

18. Each proposer must complete and submit with its proposal the following non-discrimination and affirmative action forms: the Notification to Proposers, Contract Compliance, and EEO-1. It shall not be sufficient to declare or state that such forms are on file with the State of Connecticut. Failure to include the required forms shall result in rejection of the proposal.

**C. Samples**

1. Samples, when required by the RFP, must be submitted strictly in accordance with the requirements of the RFP.
2. Any and all required samples shall be furnished by the proposer at no cost to CSU. All samples, unless otherwise indicated, will become the property of CSU and will not be returned to the proposer unless the proposer states in the proposal that the sample's return is requested. A sample will be returned on the request of the proposer if the sample has not been rendered useless or beyond its useful life. The proposer must pay the costs associated with the return of any sample. Samples may be held by CSU for comparison with actual product deliveries.
3. The making of chemical and physical tests of samples submitted with proposals shall be made in the manner prescribed by CSU.

**D. Bonding Requirements / Guaranty or Surety**

1. If required by this RFP, the proposal must be accompanied by a bid bond or a certified check in an amount that is ten percent (10%) of the bid amount. The bid bond must be executed by an insurance company licensed to do business in the State of Connecticut. Certified checks must be made payable to CSU or the appropriate CSU University.
2. The proposal bond must be executed by the proposer as follows:
  - (a) If the proposer is a corporation - must be signed by an official of the corporation above his or her official title, and the corporate seal must be affixed over the signature;
  - (b) If the proposer is a partnership - must be signed by a general partner;
  - (c) If the proposer is an individual - must be signed by the individual and indicate that he or she is "doing business as . . . ."
3. The surety company executing the bond or countersigning must be licensed in Connecticut and the bond must be signed by an official of the surety company with the corporate seal affixed over his or her signature. Signatures of two witnesses for both the principal and the surety must appear on the bond.

**III. CONTRACT AWARD**

1. All proposals properly submitted will be opened and read publicly. Upon award, the proposals are subject to public inspection. CSU will not prepare abstracts of proposals received for distribution, nor will information concerning the proposals received be conveyed by telephone.
2. Award will be made to the lowest responsible qualified proposer who complies with the proposal requirements. Price alone need not be the sole determining factor for an award. Other criteria, listed in the RFP, may be considered by CSU in the award determination.
3. CSU reserves the right to grant an award and/or awards by item, or part thereof, groups of items, or all items of the proposal and to waive minor irregularities and

omissions if, in CSU's judgment, the best interests of CSU or the State of Connecticut will be served.

4. CSU reserves the right to correct inaccurate awards resulting from its administrative errors.
5. The Award Notice and Offer (to enter into a formal contract) shall be sent to the awarded proposer by first class certified mail, return receipt requested, to the address provided in the awarded proposal, or by overnight courier. The Notice and Offer shall constitute an offer by CSU to enter into negotiations to come to a formal contract agreement. If the proposer, within ten (10) business days of receipt of said Notice and Offer, declines to begin contract negotiations, then the offer to negotiate a contract may be withdrawn and an offer to negotiate a contract extended to the next lowest responsible qualified proposer, and so on until a contract is negotiated and executed.
6. Each proposal submitted shall constitute an offer by the proposer to furnish any or all of the commodities or services described therein at the prices given and in accordance with conditions set forth in the proposal, the RFP, and these "Standard Terms and Conditions." Acceptance and resulting contract formation shall be in a formal written document authorized by CSU's Purchasing Department and where applicable, approved by the Attorney General, and shall comprise the entire agreement between the proposer and CSU.

#### **IV. TERMS AND CONDITIONS RELATED TO CONTRACT WITH SUCCESSFUL PROPOSER**

By submitting a response to the RFP, the proposer agrees that any contract negotiated between it (if the successful proposer), as contractor, and CSU may contain the following provisions, as deemed applicable by CSU:

##### **A. General Conditions**

1. Any product developed and accepted by CSU under a contract awarded as a result of an RFP shall be sole property of CSU, unless stated otherwise in the contract.
2. Data collected or obtained by the contractor in connection with the performance of the contract shall not be shared with any third party without the express written approval of CSU.
3. The contractor shall defend, indemnify and hold harmless CSU, its officers and employees, against any and all suits, actions, legal or administrative proceedings, claims, demands, damages, liabilities, monetary loss, interest, attorney's fees, costs and expenses of whatsoever kind or nature arising out of the performance of the agreement, including those arising out of injury to or death of contractor's employees or subcontractors, whether arising before, during or after completion of the services thereunder and in any manner directly or indirectly caused, occasioned or contributed to in whole or in part, by reason of any act, omission, fault or negligence of contractor or its employees, agents or subcontractors. Without limiting the foregoing, the contractor shall defend, indemnify and hold CSU and the State of Connecticut harmless from liability of any kind for the use of any copyright or un-copyrighted composition, secret process, patented or unpatented invention furnished or used in the performance of the contract. This indemnification shall be in addition to the warranty obligations of the contractor and shall survive the termination or cancellation of the contract or any part thereof.
4. The contractor shall: (i) guarantee its products against defective materials and workmanship; (ii) repair

damage of any kind, for which it is responsible, to CSU's premises or equipment, to its own work or to the work of other contractors; (iii) obtain and pay for all applicable licenses, permits, and notices; (iv) give all notices and comply with all requirements of the municipality in which the service is to be provided and of the State and federal governments; and (v) carry proper and sufficient insurance to protect the State from loss.

5. The contract shall be interpreted and governed by the laws of the State of Connecticut, without regard to its principles of conflicts of laws.
6. The contractor agrees that it shall be subject to and abide by all applicable federal and state laws and regulations.
7. The contractor agrees that it shall comply with Section 4a-60 of the Connecticut General Statutes and with Executive Orders Nos. 3, 16, 17 and 7C.
8. The contractor agrees that the sole and exclusive means for the presentation of any claim against the State of Connecticut, the Connecticut State University or the Board Of Trustees arising from a contract with CSU, shall be in accordance with the provisions of Chapter 53 of the Connecticut General Statutes (Claims Against the State) and that no additional legal proceedings will be initiated in any state or federal court in addition to, or in lieu of, said Chapter 53 proceedings.
9. The contractor agrees that CSU shall have and retain sole and exclusive right and title in and to the forms, maps, and/or materials produced for CSU pursuant to the contract, including all rights to use, distribute, sell, reprint, or otherwise dispose of same. The contractor further agrees that it shall not copyright, register, distribute, or claim any rights in or to said maps and/or materials or the work produced under the contract.
10. The contractor or subcontractor, as applicable, shall offer and agree to assign to CSU all rights, title and interest in and to all causes of action it may have under Section 4 of the Clayton Act, 15 U.S.C. 15, or under Chapter 624 of the general statutes, arising from the purchase of services, property or intangibles of any kind pursuant to a public purchase contract or subcontract; such assignment shall be made and become effective at the time the contract is executed by the parties, without further acknowledgment by them.
11. The contractor shall not assign or otherwise dispose of the contract or its right, title or interest therein, or its power to execute such contract, to any other person without the prior written consent of CSU.
12. CSU reserves the right to inspect commodities for conformance with proposal specifications. When commodities are rejected by CSU, said commodities shall be removed by the contractor, at the contractor's expense, from the CSU premises within forty-eight (48) hours after notification of such rejection, unless public health and safety require immediate destruction or other disposal of such rejected delivery. Rejected items left longer than forty-eight (48) hours shall be considered abandoned by the contractor and CSU shall have the right to dispose of them as its own property.
13. If any provision, term or condition of the contract is prohibited, invalid, or unenforceable then that provision, term or condition shall be ineffective to the extent of the prohibition, invalidity, or prohibition without invalidating the remaining provisions, terms and conditions unless it materially alters the nature or intent thereof.
14. Should the terms of any purchase order or invoice issued in connection with the contract conflict with the

terms of the contract, the terms of the contract shall prevail.

15. Failure of the contractor to deliver commodities or perform services as specified in the contract will constitute authority for CSU to purchase these commodities or services on the open market. The contractor shall promptly reimburse CSU for excess costs incurred by CSU due to these purchases, and these purchases shall be deducted by CSU from the quantities contracted for.
16. No right or duty, in whole or in part, of the contractor under the contract may be assigned or delegated without the prior written consent of CSU. The subcontracting or assignment of any of contractor's obligations under the contract to a subcontractor shall require the prior written approval of CSU.
17. Upon termination of the contract by CSU, the contractor shall both immediately discontinue all services (unless the notice directs otherwise) and deliver to CSU all data, drawings, specifications, reports, estimates, summaries, and such other information and materials as may have been accumulated by the contractor in performing its duties under the contract, whether completed or in progress. All such documents, information, and materials shall become the property of CSU.
18. The State of Connecticut shall assume no liability for payment for services under the terms of the contract until the contractor is notified that the contract has been accepted by CSU and, if applicable, approved by the Office of Policy and Management ("OPM") or the Department of Administrative Services ("DAS") and by the Attorney General of the State of Connecticut.

#### **B. Insurance**

1. Before commencing to perform services pursuant to the contract, the contractor shall obtain, at its own cost and for the duration of the contract, the following insurance:
  - (a) Commercial General Liability: \$1,000,000 combined single limit per occurrence for bodily injury, personal injury and property damage. Coverage shall include Premises and Operations, Independent Contractors, Products and Completed Operations, Contractual Liability and Broad Form Property Damage coverage. If a general aggregate is used, the general aggregate limit shall apply separately to the project or the general aggregate limit shall be twice the occurrence limit.
  - (b) Automobile Liability: \$1,000,000 combined single limit per accident for bodily injury. Coverage extends to owned, hired and non-owned automobiles. If the contractor does not own an automobile, but one is used in the execution of the contract, then only hired and non-owned coverage is required. If a vehicle is not used in the execution of the contract then automobile coverage is not required.
  - (c) Professional Liability: \$1,000,000 limit of liability.
  - (d) Workers' Compensation and Employers Liability: Statutory coverage in compliance with the laws of the State of Connecticut. Coverage shall include Employer's Liability with minimum limits of \$100,000 each accident, \$500,000 Disease – Policy limit, \$100,000 each employee.  
An Excess Liability/Umbrella Policy may be used to meet the minimum limit guidelines.
2. The contractor shall provide copies of its Certificates of Insurance to CSU, if requested to do so. The Certificates shall include the following:

- (a) The certificate shall clearly identify the State of Connecticut, its officers, officials, employees, agents, boards and commissions as Additional Insured. The coverage shall contain no special limitations on the scope of protection afforded to the State.

- (b) The certificate shall clearly indicate the project name and project number or some easily identifiable reference to the relationship to the State.

3. The Certificates shall be signed by a person authorized by that insurer to execute contracts on its behalf. The certificate Accord Form 25 Certificate shall indicate a minimum thirty (30) day endeavor to notify requirement in the event of cancellation or non-renewal of coverage.
4. The contractor shall assume responsibility for payment of any and all deductibles applicable to the insurance policies described in Section IV.B.1 above.
5. The contractor's insurer shall have no right of recovery or subrogation against the State and the described insurance shall be primary coverage.
6. Each required policy of insurance shall provide that it shall not be suspended, voided, cancelled or reduced except after thirty (30) days' prior written notice sent by certified mail to CSU.
7. "Claims Made" coverage shall be unacceptable, with the exception of Professional Liability.

#### **C. Bonds**

The successful proposer shall submit the following bonds, at the request of CSU, within ten (10) days of the date of receipt of the Award Notice and Offer:

1. A Performance Bond in the amount of one hundred percent (100%) of the total proposal price; and
2. A Labor and Material Payment Bond in the amount of one hundred percent (100%) of the total proposal price.

A company authorized to transact business in the State of Connecticut shall execute the bonds. Checks shall be made payable to CSU or the appropriate CSU University.

#### **D. Delivery**

1. Unless otherwise specified in the proposal, all products and equipment delivered pursuant to the contract shall be new and shall include any and all manufacturer's warranties.
2. Delivery shall be to the point specified in the contract.
3. All deliveries shall display, in plain sight, any related Purchase Order or Reference/Delivery Number. Failure to display said number may cause the shipment to be rejected and returned at the contractor's expense.
4. All deliveries shall be in compliance with Sections 22a-194 to 22a-194g of the Connecticut General Statutes related to product packaging.
5. Deliveries shall be subject to reweighing on official sealed scales designated by the State and payment shall be made on the basis of net weight of materials received.
6. Payment terms are net forty-five (45) days after receipt of goods or invoice, whichever is later. State of Connecticut certified small or minority contractors are payable under terms net thirty (30) days.
7. Monies owed to CSU or the Department of Revenue Services (DRS) by the contractor shall be deducted from current obligations.

**E. Inspection and Tests**

1. The inspection of all commodities and the making of chemical and physical tests of samples of deliveries to determine whether or not the contract specifications are being complied with shall be made in the manner prescribed by CSU.
2. Any item that fails in any way to meet the terms or specifications set forth in the contract is subject to be paid for at an adjusted price or rejected, in the discretion of CSU.
3. After delivery and installation of any equipment provided pursuant to the contract, the contractor shall certify to CSU that the equipment has been properly installed and is ready for use. Thereafter, for a test period of sixty (60) days, CSU shall operate the system in accordance with its normal operating practices. The acceptance test shall determine if the equipment's operating characteristics meet the performance standards set forth in the contract.

**F. Advertising**

Reference by the contractor to sales to CSU for advertising and promotional purposes without the prior approval of CSU shall be expressly prohibited.

**General Conditions of the Contract for Construction  
Eastern Connecticut State University  
Willimantic, Connecticut**

**Table of Contents**

<b>Article Number /Title</b>	<b>Page</b>		
1. Definitions .....	2	28. Starting Systems.....	29
2. References and Standards.....	5	29. Guarantees and Warranties.....	30
3. Conditions of Work .....	5	30. Cutting, Fitting, Patching, and Digging... ..	30
4. Correlation of Contract Documents.....	6	31. Cleaning Up.....	30
5. Supplemental Bids.....	7	32. All Work Subject to Control of the Agency .....	30
6. Commencement and Progress of Work.....	7	33. Construction Administrator .....	31
7. Project Meetings.....	8	34. Schedule of Values: Application for Payment ...	31
8. Submittals, Product Data, Shop Drawings and Samples .....	9	35. Application for Payment: General.....	32
9. Equals and Substitution ... ..	15	36. Partial Payments .....	33
10. Separate Contracts.....	17	37. Application for Payment: Substantial Completion.	33
11. Cooperation of Trades .....	17	38. Application for Payment: Final.....	34
12. Damages .....	17	39. Delivery of Statement Showing Amounts Due for Wages, Materials, and Supplies .....	34
13. Minimum Wage Rates .....	18	40. Contract Closeout.....	35
14. Posting Minimum Wage Rates .....	18	41. Operation and Maintenance Data ... ..	39
15. Construction Schedules .....	18	42. Completion and Acceptance.....	40
16. Preference in Employment .....	19	43. Final Payment.....	41
17. Modification Procedures .....	20	44. Agency's Right to Withhold Payments .....	41
18. Compensation for Changes in the Work.....	22	45. Agency's Right to Stop Work or Terminate Contract.....	42
19. Deleted Work .....	24	46. Subletting or Assigning of Contract.....	43
20. Materials: Standards .....	24	47. Contractor's Insurance .....	43
21. Quality Control... ..	25	48. Foreign Materials .....	44
22. Inspection and Tests .....	27	49. Materials and Equipment Controls... ..	45
23. Royalties and Patents.....	27	50. Identification Badges.....	45
24. Surveys, Permits, and Regulations .....	27	51. Hours of Work.....	45
25. Protection of the Work, Persons and Property.....	28	52. Days of Work .....	45
26. Temporary Utilities .....	28	53. Contract Time.....	46
27. Correction of Work.....	28	54. Calendar Day.....	46

**Article 1**  
**DEFINITIONS**

Whenever the following terms, or pronouns in place of them, are used the intent and meaning shall be as follows:

**1.1 ADDITIONAL OR DELETED WORK:** Work required, in the judgment of the Agency, involves any addition to, deduction from, or modification of the Work required by the Contract Documents.

**1.2 AGENCY:** The (User) Agency of the State of Connecticut having administrative authority of the facility in which the Work is being performed.

**1.3 APPLICATION FOR PAYMENT, PARTIAL PAYMENT OR REQUISITION:** Contractor's certified request for payment for completed portions of the Work and, if the Contract so provides, for materials or equipment suitably stored pending their incorporation into the Work.

**1.4 ARCHITECT OR ENGINEER:** An individual, partnership, firm, corporation or other business organization under contract with the Agency, commissioned to prepare Contract Drawings and specifications, to advise the Agency and in certain cases, to perform regular inspections during construction and when authorized to perform the duties of the Construction Administrator.

**1.5 BASE BID:** Monetary value stated in the Bid Proposal form as the sum for which the bidder offers to perform the Work described in the Bidding Documents, exclusive of adjustments for Supplemental Bids.

**1.6 BID BOND:** Form of bid security executed by the Bidder as Principal and by a Surety to guarantee that the Bidder will enter into a Contract within a specified time and furnish any required bond as mandated by Connecticut General Statute Section 4b-92.

**1.7 BIDDER:** An individual, partnership, firm, corporation or other business organization submitting a Bid on the Bid Proposal Form for the Work contemplated.

**1.8 BIDDING DOCUMENTS:** Collectively, the Bidding Requirements and the proposed Contract Documents, including any addenda issued prior to receipt of Bids.

**1.9 BID OR BID PROPOSAL FORM:** A complete and duly signed proposal to perform Work (or a designated portion thereof) for a stipulated sum submitted in accordance with the Bidding Documents.

**1.10 BID SECURITY:** Certified check or Bid Bond submitted with Bid Proposal Form, which provides that the Bidder, if awarded the Contract, will execute such Contract

in accordance with the requirements of the Bidding Documents.

**1.11 BUILDER'S RISK INSURANCE:** A specialized form of property insurance which provides coverage for loss or damage to the Work pursuant to the Contract Documents.

**1.12 CASH ALLOWANCE:** An amount established in the Contract Documents for inclusion in the Contract Sum to cover the cost of prescribed items not specified in detail, and as shown in the Allowance Schedule.

**1.13 CERTIFICATE of COMPLETION:** A document is-sued by the Construction Administrator to the Agency stating that the Contractor has met all contractual obligations.

**1.14 CERTIFICATE of COMPLETION and ACCEPTANCE:** A document issued by the Agency to the Contractor stating that all Work has been completed and that the Work is accepted by the Agency.

**1.15 CERTIFICATE of COMPLIANCE:** A document is-sued to the Agency by the design professional stating that for the portion of the project completed, either the design portion or the construction portion, has been performed in substantial compliance with all applicable building codes

**1.16 CERTIFICATE OF OCCUPANCY:** Document issued by the authority having jurisdiction certifying that all or a designated portion of a building is approved for its designated use.

**1.17 CERTIFICATE OF SUBSTANTIAL COMPLETION:** A document prepared by the Architect and approved by the Agency on the basis of an inspection stating:

**1.17.1** That the Work, or a designated portion thereof, is determined to be Substantially Complete;

**1.17.2** The date of Substantial Completion;

**1.17.3** The responsibilities of the Agency and the Contractor for security maintenance, heat, utilities, damage to the Work and insurance; and

**1.17.4** The time within which the Contractor shall complete the remaining work.

**1.18 CHANGE ORDER:** Written authorization signed by the Agency, authorizing a modification in the Work, an adjustment in the Contract Sum, or an adjustment in the Contract Time.

**1.19 COMMISSIONER:** The State of Connecticut, Department of Public Works (DPW) Commissioner acting directly or through specifically authorized DPW personnel or

agent(s) having authority to perform duties defined in Article 25.

**1.20 CONSTRUCTION ADMINISTRATOR:** An individual, partnership, firm, corporation or other business organization, under contract or employed by the Agency commissioned and/or authorized to oversee the fulfillment of all requirements of the Contract Documents.

**1.21 CONSTRUCTION CHANGE DIRECTIVE:** A written authorization signed by the Agency, directing a modification in the Work and stating a proposed basis for adjustment, if any, in the Contract Sum, Contract Time or both.

**1.22 CONTRACT DOCUMENTS OR CONTRACT:** The Agreement between Agency and Contractor, Conditions of the Contract (General Conditions, Supplementary Conditions, General Requirements and other Conditions), Drawings, Specifications, and Addenda issued prior to execution of the Contract, other documents listed in the Agreement and Modifications issued after execution of the Contract, all of which shall constitute the Contract.

**1.23 CONTRACTOR OR GENERAL CONTRACTOR:** An individual, partnership, firm or Corporation, under direct contract with the Agency, responsible for performing the Work under the Contract Documents. Whenever the words "Contractor" or "General Contractor" are used it shall be understood to mean Contractor.

**1.24 CONTRACTOR'S LIABILITY INSURANCE:** Insurance purchased and maintained by the Contractor that insures the Contractor for claims for property damage, bodily injury or death.

**1.25 CONTRACT START DATE OR DATE OF COMMENCEMENT OF THE WORK:** The date, specified by the Agency in the Notice to Proceed, on which the Contractor is required to start the Work.

**1.26 CONTRACT SUM:** The sum stated in the Contract, which is the total amount payable by the Agency to the Contractor for performance of the Work under the Contract Documents.

**1.27 CONTRACT TIME:** The period of time allotted in the Contract Documents for Substantial Completion of the Work, including authorized adjustments thereto. The days specified, calendar or working days, are stipulated in the Bidding Documents.

**1.28 DAY:** Whenever the word Day is used it shall be understood to mean calendar day or working day as stated on the Bidding Documents, unless stated otherwise.

**1.29 PROJECT MANAGER:** The individual employed by the Agency, to be responsible for the overall management and oversight of the Project, and to represent the Agency.

**1.30 EQUAL(S):** A replacement for the specified material, device, procedure, equipment, etc., which has been determined by the Architect and the Agency to be substantially identical to the first listed manufacturer or first listed procedure specified in terms of cost, quality and performance for the Project. The Equal does not constitute a modification in the scope of Work, the Schedule or Architect/Engineer's design intent of the specified material, device, procedure, equipment, etc.

**1.31 FINAL ACCEPTANCE:** The Agency's written approval and acceptance of the Work issued to the Contractor upon written certification by the Architect of Final Completion.

**1.32 FINAL COMPLETION:** A written statement by the Architect to the Owner that the Work has been completed in accordance with the terms and conditions of the Contract Documents.

**1.33 FINAL INSPECTION:** Review of the Work by the Architect and Agency to determine whether Final Completion has been achieved.

**1.34 FINAL PAYMENT:** The last payment made by the Owner to the Contractor, made after notice of the Final Acceptance. Payment shall include the entire unpaid balance of the Contract Sum as adjusted by Modifications.

**1.35 GENERAL CONDITIONS:** The General Conditions of the Contract for Construction, part of Division 0 of the Specifications.

**1.36 GENERAL REQUIREMENTS:** That part of the Contract Documents entitled General Requirements, which is Division 1.

**1.37 LIQUIDATED DAMAGES:** A sum established in a Contract, usually as a fixed sum per day, as the predetermined measure of damages to be paid to the Agency due to the Contractor's failure to complete the Work within the Contract Time.

**1.38 LUMP SUM:** An item or category priced as a whole rather than broken down into its elements.

**1.39 MINOR CHANGES IN THE WORK:** Changes in the Work not involving an adjustment in the Contract Sum or an extension of the Contract Time and not inconsistent with the intent of the Contract Documents, which shall be affected by written order issued by the Architect.

**1.40 MODIFICATION OR AMENDMENT:**

**1.40.1** A written change to the Contract Documents.

**1.40.2** A Change Order.

**1.40.3** A Construction Change Directive.

**1.40.4** Supplemental Instructions for minor changes in the Work and/or additional instructions to the Work.

**1.41 NOTICE TO BIDDER:** A notice contained in the Bidding Document informing prospective Bidders of the opportunity to submit Bids on a Project.

**1.42 NOTICE TO PROCEED:** Written notice, issued by the Agency to the Contractor authorizing the Contractor to proceed with the Work and establishing the date for commencement of the Contract Time.

**1.43 OWNER OR AGENCY:** Eastern Connecticut State University, Willimantic, Connecticut or specifically authorized Agency personnel or agent.

**1.44 PAYMENT BOND, LABOR BOND OR MATERIAL BOND:** A bond in which the Contractor and the Contractor's surety guarantee to the Agency that the Contractor will pay for labor and materials furnished for use in the performance of the Contract, as required by Connecticut General Statutes Section 49-41.

**1.45 PERFORMANCE BOND OR SURETY BOND:** A bond in which the Contractor and the Contractor's surety guarantee to the Agency that the Work will be performed in accordance with the Contract Documents, as required by Connecticut General Statutes Section 41.

**1.46 PERFORMANCE SPECIFICATION:** A description of the desired results or performance of a product, material, assembly, procedure, or a piece of equipment with criteria for identifying the standard.

**1.47 PLANS OR DRAWINGS:** All drawings or reproductions of drawings pertaining to the construction of the Work contemplated and its appurtenances.

**1.48 PROJECT:** The total construction of which the Work performed under the Contract Documents may be the whole or a part.

**1.49 PROJECT MANUAL:** The set of documents assembled for the Work which includes, but is not limited to, Contract Documents, Bidding Requirements, Sample Forms, Conditions of the Contract, General Requirements and the Specifications.

**1.50 PROPRIETARY SPECIFICATION:** A specification that describes a product, procedure, function, material, assembly, or piece of equipment by trade name and/or by naming the manufacturer(s) or manufacturer's procedure, exact model number, item, etc., of those products acceptable to the Agency.

**1.51 RECORD DOCUMENTS OR AS-BUILT DRAWINGS:** Construction Drawings revised to show all significant Modifications made during the construction process.

**1.52 SCHEDULE:** A Critical Path Method (CPM) or Construction Schedule as required by the Contract Documents which shall be a diagram, graph or other pictorial or written schedule showing all events expected to occur and operations to be performed and indicating the contract time, start dates, durations and finish dates and their relationship to Substantial Completion and Final Completion of the Work, rendered in a form permitting determination of the optimum sequence and duration of each operation.

**1.53 SCHEDULE OF VALUES:** A document furnished by the Contractor to the Architect and Agency stating the portions of the Contract Sum allocated to the various portions of the Work, which is to be used for reviewing the Contractor's Applications for Payment.

**1.54 SECONDARY SUBCONTRACTOR:** An individual, partnership, firm or Corporation under direct contract with the Subcontractor to the General Contractor.

**1.55 SHOP DRAWINGS:** Drawings provided to Architect and Agency by a Contractor that illustrate construction, materials, dimensions, installation, and other pertinent information for the incorporation of an element or item into the construction as detailed Contract Documents.

**1.56 SPECIFICATIONS:** The description, provisions and other requirements pertaining to the method and manner of performing the Work and/or to the quantities and quality of materials to be furnished under the Contract.

**1.57 SUBCONTRACTOR:** A person, partnership, corporation or other business organization under direct contract with the Contractor supplying labor and/or materials for the Work at the site of the Project.

**1.58 SUBMITTALS:** Documents including, but not limited to, samples, manufacturer's data, shop drawing, or other such items submitted to the Agency and Architect by the Contractor for the purpose of approval or other action, as required by the Contract Documents.

**1.59 SUBSTANTIAL COMPLETION:** The stage in the progress of the Work when the Work or designated portion

thereof is sufficiently complete in accordance with the Contract Documents so the Agency can occupy or utilize the Work for its intended use.

**1.60 SUBSTITUTION:** A material, device, procedure, equipment, etc., which has been determined by the Architect and the Agency to be not an Equal to the first manufacturer or procedure listed in the Specification in terms of cost, quality and performance but which may be used in place of that item specified. . The Substitution constitutes a modification in the Work, the Schedule or the Architect/Engineer's design intent of the specified material, device, procedure, equipment, etc.

**1.61 SUPPLEMENTAL BID:** The monetary value stated in the Bid to be added to the amount of the Base Bid if the corresponding Work, as described in the Bidding Documents, is accepted.

**1.62 SUPPLEMENTARY CONDITIONS:** An extension of the General Conditions applicable to any and all portions of Work under the Contract Documents.

**1.63 THRESHOLD LIMIT BUILDING:** Any proposed (new) structures or additions as defined by the Connecticut General Statutes Section 29-276b.

**1.64 UNIT PRICE:** The monetary value stated by the Agency or the Contractor, as a price per unit of measure for materials or services as described in the Contract Documents and/or Bidding Documents.

**1.65 WORK:** The construction and services required by the Contract Documents, and including all labor, materials, equipment and services provided or to be provided by the Contractor to fulfill the Contractor's obligations. The Work may constitute the whole or a part of the Project.

### **Article 2**

#### **REFERENCE STANDARDS AND DEFINITIONS**

**2.1** For products specified by association or trade standards, comply with requirements of the standard, except when more rigid requirements are specified or are required by applicable codes.

**2.2** References to standard specifications and codes refer to the editions current at the bid due date. An exception is, buildings exceeding the threshold limit must be in substantial compliance with the requirements of the effective code at the time of receipt of completed application to the Office of State Building Inspector (OSBI). References include their addenda and errata, if any, and shall be considered a part of these specifications as if they were printed herein in full.

**2.3** The manufacturers' standard warranties or guarantees shall apply when their products are used on this project.

**2.4** Flame Spread Ratings - all materials that are required or obligated to meet specified standards shall be submitted to the owner for their records as part of the shop drawing submittal process for their construction records.

### **Article 3**

#### **CONDITIONS OF WORK**

**3.1** The Contractor shall carefully examine and study the conditions under which the Work is to be performed and the site of the Work, and compare the Contract Documents with each other and to information furnished by the Agency including but not limited to the plans and specifications, the form of the Contract, General Conditions, Supplementary Conditions, General Requirements, Bonds and all other Contract Documents associated with the Work.

**3.2** The Contractor shall report to the Construction Administrator all errors, inconsistencies or omissions discovered. The Contractor shall not be liable to the Agency for damage resulting from errors, inconsistencies or omissions in the Contract Documents unless the Contractor recognized such errors, inconsistencies or omission and failed to report it to the Construction Administrator. If the Contractor performs any actions or construction activity knowing it involves an error, inconsistency or omission in the Contract Documents without notice to the Construction Administrator, the Contractor shall assume responsibility for such performance and related costs for the correction and shall not be allowed to submit any claim related to error, inconsistencies or omission.

**3.3** It shall be the Contractor's responsibility upon discovery to immediately notify the Construction Administrator, in writing, of errors, omissions, discrepancies, and instances of noncompliance with applicable codes and regulations within the documents, and of any work which will not fit or properly function if installed as indicated on the Contract Documents. Any additional costs arising from the Contractor's failure to provide such notification shall be borne by the Contractor.

**3.4** The Contractor shall take field measurements and verify field conditions and shall carefully compare such field measurements and conditions and other information known to the Contractor with the Contract Documents before commencing activities. Errors, inconsistencies or omissions discovered shall be reported to the Construction Administrator at once; and it will be assumed that the Contractor has been satisfied as to all requirements of the Contract Documents. Any deterrent conditions at the site of the Work which are obvious and apparent upon examination of the site but are not indicated on the plans shall be corrected by the Contractor without additional compensation.

**3.5** It is not the intent of the Documents to show all existing conditions. All contractors are advised and required to visit and examine the site with the Construction Administrator prior to submitting bids. If conflicts are noted the Contractor shall notify the Agency as soon as possible prior to bid date. If a conflict appears during construction notify the Construction Administrator, in writing, as soon as possible -- Do not proceed without direction from the Construction Administrator.

**3.6** Where existing objects or conditions are uncovered and exposed, subsequent to the issuance of the Contract, the Contractor and the Construction Administrator will jointly inspect these conditions and their findings will be recorded in writing by the Contractor. All corrective measures jointly agreed upon will be recorded in detail sufficient to prevent confusion and conflict at a later date.

**3.7** The Contractor will proceed with the Work in these areas, taking into consideration these newly exposed conditions, and will adjust its working procedures to compensate for these conditions.

**3.8** Contractors should investigate and satisfy themselves as to the conditions affecting the work, including but not restricted to those bearing upon transportation, disposal, handling and storage of materials, availability of labor, water, electric power, uncertainties of weather, roads or similar physical conditions of the ground, the character of equipment, and facilities needed preliminary to and during the prosecution of the Work. The Contractor should further satisfy himself as to the character, quality, and quantity of surface and subsurface materials or obstacles to be encountered insofar as this information is reasonably ascertainable from an inspection of the site, as well as from information presented by the Contract Documents. Any failure by the Contractor to acquaint himself with the available information shall not relieve him from the responsibility for estimating properly the difficulty and cost of successfully performing the Work.

**3.9** If applicable to this Project a review of Geo-Technical Reports, Boring Logs Asbestos, Hazardous Materials and Confined Space parameters are contained in a separate Volume of this Project Manual, the Boring Location Plans are in the Contract Documents.

**3.10** A Pre-Bid Conference and tour of the site will be conducted as scheduled in the Notice to Bidders. This scheduled conference is the only official opportunity for the bidders to tour the site with the Agency, Architect, Engineer, Construction Administrator, and Consultants.

**3.11** In performing the Work, the Contractor must employ such methods or means as will not cause any interruption of or interference with the Work of any other Contractor, nor any inordinate disruption with the normal routine of the Institution or Agency operating at the site.

**3.12** No claims for additional compensation will be considered when additional costs result from conditions made known to, discovered by, or which should have been discovered by, the Contractor prior to Contract signing.

**3.13** The Contractor shall perform the Work in accordance with the Contract Documents and approved submittals pursuant to Article 8.

#### **Article 4** **CORRELATION OF CONTRACT DOCUMENTS**

**4.1** The Contract Documents are complementary, and what is called for by any one shall be as binding as if called for by all. The Specifications and Drawings are intended to describe and illustrate the materials and labor necessary for the work of this Project. Where discrepancies of conflict occur in the Contract Documents the following order of precedence shall be utilized:

**4.1.1** Amendments and addenda shall take precedence over previously issued Contract Documents.

**4.1.2** The General Requirements take precedence over the Supplementary Conditions.

**4.1.3** The Supplementary Conditions take precedence over the General Conditions.

**4.1.4** The General Requirements take precedence over the General Conditions.

**4.1.5** The Specifications shall take precedence over the Plans.

**4.1.6** Stated dimensions shall take precedence over scaled dimensions.

**4.1.7** Large-scale detail drawings shall take precedence over small-scale drawings.

**4.1.8** The schedules contained in the Contract Documents shall take precedence over other data on the Plans.

**4.2** Neither party to the Contract shall take advantage of any obvious error or apparent discrepancy in the Contract Documents. The Contractor shall give immediate written notification of any error or discrepancy discovered to the Construction Administrator, who shall take the necessary actions to obtain such corrections and interpretations as may be deemed necessary for the completion of the Work in a satisfactory and acceptable manner. The Contractor shall then promptly proceed under the direction of the Agency and the provisions of Article 13. The Contractor's failure to provide immediate notice shall mean the Contractor will not be entitled to any additional compensation, either monetary or contract time adjustment, with respect to any discrepancy.

**4.3** Execution of the Contract by the Contractor is a representation that the Contractor has visited the site, become familiar with local conditions under which the Work is to be performed and correlated personal observations with requirements of the Contract Documents.

**4.4** Organization of the Specifications into divisions, sections and articles, and arrangement of drawings, shall not control the Contractor in dividing the Work among Subcontractors or in establishing the extent of Work to be performed by any trade.

**4.5** Unless otherwise stated in the Contract Documents, words which have well-known technical or construction industry meanings are used in the Contract Documents in accordance with such recognized meanings.

**4.6** Throughout the Technical Specifications, the Connecticut Department of Transportation Standard Specifications for Roads, Bridges, and Incidental Construction Form 816, current addition including any interim and supplemental specifications may be referenced. Where so referenced the requirements set forth therein are applicable and made a

part hereof Copies of Form 816 are available from the Connecticut Department of Transportation at a nominal charge.

## **Article 5** **SUPPLEMENTAL BID**

**5.1** Definition: A Supplemental Bid is an amount proposed by bidders and stated on the Bid Proposal Form for certain work defined in the Bidding Documents that may be added to the Base Bid amount if the Owner decides to accept a corresponding change in either the amount of construction to be completed, or in the products, materials, equipment, systems, or installation methods described in the Contract Documents.

**5.2** The cost for each supplemental bid is the net addition to the Contract Sum to incorporate the Supplemental Bid into the Work. Supplemental Bids are only accepted in the numerical order that they are listed on the Bid Proposal Form and never accepted out of numerical sequence. No other adjustments are made to the Contract Sum.

**5.3** Coordination: Modify or adjust affected adjacent Work as necessary to completely and fully integrate that Work into the Project.

**5.4** Include as part of each Supplemental Bid, miscellaneous devices, accessory objects, and similar items incidental to or required for a complete installation whether or not mentioned as part of the Supplemental Bid.

**5.5** Execute accepted Supplemental Bids under the same conditions as other Work of this Contract.

**5.6** Schedule: A "Schedule of Supplemental Bids" is included within the Supplementary General Requirements (Section 01030 Supplemental Bids. Specification Sections referenced in the Schedule contain requirements for materials necessary to achieve the Work described under each Supplemental Bid.

## **Article 6** **COMMENCEMENT AND PROGRESS OF WORK**

**6.1** The Work shall start upon the date given in the Notice to Proceed. The Contractor shall complete all the Work necessary for Final Completion, including but not limited to Substantial Completion, Contract close-out, testing and demonstration of all systems as required for acceptance, punchlist Work, training and submission of Record Documents, manuals, guarantees and warranties as stated in the Bidding Document.

**6.2** Time is of the essence with respect to the Contract Time. By executing the Contract, the Contractor confirms and agrees that the Contract Time is a reasonable period to perform the Work. The Contractor shall proceed expeditiously with adequate forces and shall achieve Substantial Completion within the Contract Time. The Contractor may, at his discretion, plan to complete the work and achieve Substantial Completion in less time than the Contract Time.

**6.3** The Contractor's early completion schedule notwithstanding, the Agency reserves the right to order Modifications to the Work in accordance with Article 13 at any time during the Contract Time.

**6.4** The Contractor shall not be entitled to costs for delay due to Agency ordered Modifications or any other circumstances for the period of time between the Contractor's elected early completion and the end of the Contract Time. Costs include, but are not limited to, delays extended home or field office costs, supervisory and management costs incurred in performance of the Work. Early completion of the Work shall not merit additional compensation.

**6.5** If the Contractor is delayed at any time in the progress of Work by acts of God such as fire or flood or any action, injunction or stop order issued by any court, judge or officer of the court or any other court action beyond the Agency's control, then the Contract Time may be extended by Change Order for such reasonable time as demonstrated by the Contractor's Schedule and as the Agency may determine that such event has delayed the Work. In any event, the granting of an extension of time shall be solely within the discretion of the Agency.

**6.6** Except as otherwise may be provided herein, extensions of time shall be the Contractor's sole remedy for such delay. No payment or compensation of any kind shall be made to the Contractor for damages because of hindrance in the orderly progress of Work caused by the aforesaid causes.

**6.7** The Contractor acknowledges that the Contract amount includes and anticipates any and all delays, whether avoidable or unavoidable, from said orders, which may issue from any court, judge, court officer, or act of God, and that such delays shall not, under any circumstances, be construed as compensable delays.

**6.8** Any extension of the Contract Time shall be by Change Order pursuant to Article 17 and Article 18.

**7.1** Pre-construction Conference: The Contractor will attend a Pre-construction Conference before starting construction, as scheduled by the Construction Administrator convenient to the Agency, the Construction Administrator, Architect, and Contractor. This meeting will take place within seven (7) Calendar Days after the written Notice to Proceed and before the Contract Start Date. Hold the conference at the Project Site or another convenient location as directed by the Construction Administrator. The Construction Administrator shall conduct the Pre-construction Conference to review the Contractor and Subcontractor responsibilities and personnel assignments. NOTE: Amplify the paragraph below as necessary to suit project requirements.

**Article 7**  
**PROJECT MEETINGS**

**7.1.1 Attendees:** Authorized representatives of the Construction Administrator, Agency, Architect, and their consultants; the Contractor and its superintendent; major subcontractors; agency; and other concerned parties shall attend the conference. All participants at the conference shall be familiar with the Project and authorized to conclude matters relating to the Work.

**7.1.2 Agenda:** Discuss items of significance that could affect progress, including the following:

- a. Tentative construction schedule.
- b. Critical work sequencing.
- c. Progress meeting schedule.
- d. Designation of responsible personnel.
- e. Procedures for processing field decisions and Change Orders.
- f. Procedures for processing Applications for Payment.
- g. Distribution of Contract Documents.
- h. Submittal of Shop Drawings, Product Data, and Samples.
- i. Preparation of record documents.
- j. Use of the premises.
- k. Parking availability.
- l. Office, work, and storage areas.
- m. Equipment deliveries and priorities.
- n. Safety procedures.
- o. First aid.
- p. Security.
- q. Housekeeping.
- r. Plan of Use
- s. Substitutions
- t. Safety – Conn OSHA
- u. Working hours.
- v. Coordination with Audio-Visual and Telecommunications.

**7.2 Progress Meetings:** The Construction Administrator will conduct progress meetings, weekly, at the Project Site or at regular intervals as agreed upon at the Pre-construction Conference. The Construction Administrator will notify the Agency, the Architect, and the Contractor of the scheduled Progress Meeting dates. Coordinate dates of Progress Meetings with preparation of Application for Payment requests.

**7.2.1 Attendees:** In addition to representatives of the Contractor, Construction Administrator, Agency and the Architect, subcontractor, supplier, or other entity concerned with current progress or involved in planning, coordination, or performance

of future activities may be requested to attend these meetings on an as needed basis. All participants at the meeting shall be familiar with the Project and authorized to conclude matters relating to the Work. The Contractor shall include the site superintendent as a minimum.

**7.2.2 Agenda:** Progress Meetings shall review and correct or approve minutes of the previous Progress Meeting. Review other items of significance that could affect progress. Include topics for discussion as appropriate to the status of the Project.

**7.2.3 Construction Schedule:** Review progress since the last Progress Meeting. Determine where each activity is in relation to the required Contractor's "Construction Schedule" and whether each activity is on time or ahead or behind Schedule. Determine how Work that is behind Schedule will be expedited; secure commitments from parties involved to do so. Discuss whether Schedule revisions are required to insure that current and subsequent activities will be completed within the Contract Time.

**7.2.4** Review the present and future needs of each entity present.

**7.2.5 Reporting:** The Construction Administrator will distribute minutes of the meeting to each party present, promptly and before the next scheduled meeting, and to parties who should have been present.

**7.2.6** A schedule of regular Project Meetings will be established at the Pre-construction Conference.

## **Article 8** **SUBMITTALS, PRODUCT DATA, SHOP** **DRAWINGS AND SAMPLES**

**8.1** Contractor shall review, approve and submit to the Construction Administrator/Agency all submittals including but not limited to Product Data, Shop Drawing and Sample Manufacturers, with such promptness as to cause no delay in the Work.

**8.2** Correction or approval of such submittals, Shop Drawings, Product Data sample will be made with reasonable promptness by the Architect. Approval will be general only and shall not relieve the Contractor from responsibility for errors in dimensions, for construction and field coordination of the Work or for any departure from the Contract

Documents unless such departure has received the Agency's written approval.

**8.3** No Work governed by such drawings, schedules or samples shall be fabricated, delivered or installed until approved by the Architect.

**8.4** No damages for delays or time extensions will be granted even if approvals deviate from the approved Schedule.

**8.5** Summary: This Section includes administrative and procedural requirements for submittals required for performance of the Work, including but not limited to the following:

- a. Submittal schedule.
- b. Shop Drawings.
- c. Product Data.
- d. Samples.
- e. Quality assurance submittals.
- f. Proposed "Substitutions Request" form.
- g. Warrantee samples.
- h. Coordination Drawings.
- i. O & M Manuals
- j. Plan of Use

**8.6** Administrative Submittals: Refer to other Division 1 Sections and other Contract Documents for requirements for administrative submittals. Such submittals include, but are not limited to, the following:

- a. Permits.
- b. Applications for Payment.
- c. Performance and payment bonds.
- d. Contractor's construction schedule.
- e. Daily construction reports.
- f. Construction Photographs.
- g. Insurance certificates.
- h. List of subcontractors.
- i. Subcontractors/Suppliers FEIN numbers and Connecticut tax registration number.

**8.7** Coordination Drawings are to show the relationship and integration of different construction elements that require careful coordination during fabrication or installation to fit in the space provided or to function as intended and as identified within the Contract Documents.

**8.7.1** Preparation of Coordination Drawings is specified in Division 1 Section "Coordination" and may include components previously shown in detail on Shop Drawings or Product Data.

**8.7.2** Field samples are full-size physical examples erected on-site to illustrate finishes, coatings, or finish materials. Field samples are used to estab-

lish the standard by which the Work will be judged.

**8.7.3** Submittal Procedures: Coordinate preparation and processing of submittals with performance of construction activities. Transmit each submittal sufficiently in advance of performance of related construction activities to avoid delay.

**8.7.4** Coordinate each submittal with fabrication, purchasing, testing, delivery, other submittals, and related activities that requires sequential activity.

**8.7.5** Coordinate transmittal of different types of submittals for related elements of the Work so processing will not be delayed by the need to review submittals concurrently for coordination.

**8.7.6** The Architect reserves the right to withhold action on a submittal requiring coordination with other submittals until all related submittals are received.

**8.7.7** The Architect reserves the right to reject incomplete submitted packages.

**8.7.8** Processing: To avoid the need to delay installation as a result of the time required to process submittals, allow sufficient time for submittal review, including time for resubmittals.

- a. Allow (2) two weeks for initial review. Allow additional time if the Architect must delay processing to permit coordination with subsequent submittals.
- b. If an intermediate submittal is necessary, process the same as the initial submittal.
- c. Allow (2) two for reprocessing each submittal.
- d. No extension of Contract Time will be authorized because of failure to transmit submittals to the Architect sufficiently in advance of the Work to permit processing.

**8.9** Submittal Preparation: Place a permanent label, title block or 8-1/2 inches x 11 inches cover page approved by the Architect, on each submittal for identification. Indicate the name of the entity that prepared each submittal on the label or title block.

**8.9.1** The minimum number of copies required for each submittal shall be at a minimum 7 copies or

as determine otherwise at the pre-construction conference or by the Construction Administrator.

**8.9.2** Provide a space approximately 4 inches by 5 inches on the label, beside the title block or on the cover page on Shop Drawings to record the Contractor's review and approval markings and the action taken.

**8.9.3** Include the following information on the label for processing and recording action taken.

- a. Project Name and State of Connecticut Project Number.
- b. Date.
- c. Name and address of the Architect, Construction Administrator, and Owner Representative.
- d. Name and address of the Contractor.
- e. Name and address of the subcontractor.
- f. Name and address of the supplier.
- g. Name of the manufacturer.
- h. Number and title of appropriate Specification Section.
- i. Drawing number and detail references, as appropriate.
- j. Indicate either initial or resubmittal.
- k. Indicate deviations from Contract Documents.
- l. Indicate if "equal" or "substitution".

**8.10** Submittal Transmittal: Package each submittal appropriately for transmittal and handling. Transmit each submittal from the Contractor to the Architect using a transmittal form. Copy the Construction Administrator on the transmittal and one copy of the submittal. The Architect will return submittals to the Contractor after action is taken with a complete copy of the submittal package to the Construction Administrator.

**8.10.1** On the transmittal, record relevant information and requests for data. On the form, or separate sheet, record deviations from Contract Document requirements, including variations and limitations. Include Contractor's certification that information complies with Contract Document requirements.

**8.11** Submittal Schedule: After development and review by the Construction Administrator and Architect acceptance of the Contractor's Construction Schedule prepare a complete Schedule of Submittals. Submit the schedule to the Construction Administrator within seven (7) days of Contract Award.

**8.11.1** Coordinate Submittal Schedule with the list of subcontracts, Schedule of Values, and the list of products as well as the Contractor's Construction Schedule.

**8.11.2** Prepare the schedule in chronological order. Provide the following information:

- a. Related section number.
- b. Schedule date for the initial submittal.
- c. Submittal category (Shop Drawings, Product Data, or Samples).
- d. Name of Subcontractor.
- e. Description of the part of Work covered.
- f. Scheduled date for resubmittal.
- g. Scheduled date for the Architect's final release of approval.

**8.11.3** Distribution: Following response to the initial submittal schedule, print and distribute copies to the Construction Administrator, Architect, subcontractors, and other parties required to comply with submittal dates indicated. Post copies in the Project meeting room and field office.

**8.11.4** When revisions are made, distribute to the same parties and post in the same locations. Delete parties from distribution when they have completed their assigned portion of the Work and are no longer involved in construction activities.

**8.11.5** Schedule Updating: Revise the schedule after each meeting or activity where revisions have been recognized or made. Issue the updated schedule concurrently with the report of each meeting.

**8.12** Daily Construction Reports: Prepare a daily construction report recording the following information concerning events at the site, and submit duplicate copies to the Construction Administrator at weekly intervals:

- a. List of subcontractors at the site.
- b. Approximate count of personnel at the site.
- c. High and low temperatures, general weather conditions.
- d. Accidents and unusual events.
- e. Meetings and significant decisions.
- f. Stoppages, delays, shortages, and losses.
- g. Meter readings and similar recordings.
- h. List of equipment on site and identify if idle or in use.
- i. Orders and requests of governing authorities.
- j. Change Orders received, start and end dates.
- k. Services connected, disconnected.
- l. Equipment or system tests and startups.

- m. Partial Completion's, occupancies.
- n. Substantial Completion's authorized.
- o. Equals or Substitutions approved or rejected.
- p. Sub-Contractors meeting minutes.
- q. Safety Meeting minutes.

**8.13 Shop Drawings:** Submit newly prepared information drawn accurately to scale. Highlight, encircle, or otherwise indicate deviations from the Contract Documents. Do not reproduce Contract Documents or copy standard information as the basis of Shop Drawings. Standard information prepared without specific reference to the Project is not a Shop Drawing.

**8.13.1** Shop Drawings include fabrication and installation Drawings, setting diagrams, schedules, patterns, templates and similar Drawings. Include the following information:

- a. Dimensions:
- b. Identification of products and materials included by sheet and detail number.
- c. Compliance with specified standards.
- d. Notation of coordination requirements.
- e. Notation of dimensions established by field measurement.
- f. Sheet Size: Except for templates, patterns and similar full-size Drawings, submit Shop Drawings on sheets at least 8-1/2 by 11 inches but no larger than 36 by 48 inches.
- g. Submit one (1) reproducible media and seven (7) prints as directed by the Construction Administrator. The Contractor's submittal shall identify the specification section and/or drawing number applicable to the submittal.
- h. Details shall be large scale and/or full size.

**8.13.2** The Contractor shall review the Shop Drawings, stamp with this approval, and submit them with reasonable promptness and in orderly sequence so as to cause no delay in his Work or in the Work of any subcontractor. Shop Drawings shall be properly identified as specified for item, material, workmanship, and project number. At the submission, the Contractor shall inform the Architect, in writing of any deviation in the shop drawings from the requirements of the Contract Documents.

**8.13.3** The Architect will review and comment on shop drawings with reasonable promptness so as to cause no delay, but only for conformance with the design concept of the project and with the information given in the Contract Documents. Shop Drawings received by the Architect that indicate insufficient study of drawings and specifications, illegible portions or gross errors, will be rejected outright. Such rejections shall not constitute an acceptable reason for granting the Contractor additional time to perform the work.

**8.13.4** The Contractor shall make any corrections required by the Architect and shall resubmit the required number of corrected copies of shop drawings until fully reviewed.

**8.13.5** Upon final review submit four (4) additional prints, same as submitted, to the Construction Administrator for his use.

**8.13.6** The Architect's review and comments on shop drawings shall not relieve the Contractor of responsibility for any deviation from the requirements of the Contract Documents.

**8.13.7** Only final reviewed shop drawings are to be used on the project site.

**8.13.8** The Work installed shall be reviewed in accordance with the shop drawings and the drawings and specifications. Final Review of the shop drawings by the Architect shall constitute acceptance by the State and the Architect of a variation or departure that is clearly identified. Final reviewed shop drawings shall not replace or be used as a vehicle to issue or incorporate change orders.

**8.14 Product Data:** Collect Product Data into a single submittal for each element of construction or system. Product Data includes printed information, schedules, such as manufacturer's installation instructions, catalog cuts, standard color charts, roughing-in diagrams and templates, standard wiring diagrams, and performance curves.

**8.14.1** Mark each copy to show applicable choices and options. Where printed Product Data includes information on several products that are not required, mark copies to indicate the applicable information. Include the following information:

- a. Manufacturer's printed recommendations.
- b. Compliance with trade association standards.
- c. Compliance with recognized testing agency standards.
- d. Application of testing agency labels and seals.
- e. Notation of dimensions verified by field measurement.

- f. Notation of coordination requirements.

**8.14.2** Do not submit Product Data until compliance with requirements of the Contract Documents has been confirmed.

**8.14.3** Preliminary Submittal: Submit a preliminary single copy of Product Data where selection of options is required.

**8.14.4** Submittals: Submit 7 copies of each required submittal; submit an additional 3 copies where required for maintenance manuals. The Architect will retain one and will return the others marked with action taken and corrections or modifications required.

**8.14.5** Unless noncompliance with Contract Document provisions is observed, the submittal may serve as the final submittal.

**8.14.6** Distribution: Furnish copies of final submittal to installers, subcontractors, suppliers, manufacturers, fabricators, and others required for performance of construction activities. Show distribution on transmittal forms.

**8.14.7** Do not proceed with installation until a copy of Product Data is in the Installer's possession.

**8.14.8** Do not permit use of unmarked copies of Product Data in connection with construction.

**8.15** Samples: Submit full-size, fully fabricated Samples cured and finished as specified and physically identical with the material or product proposed. Samples include partial sections of manufactured or fabricated components, cuts or containers of materials, color range sets, and swatches showing color, texture, and pattern.

**8.15.1** Store, mount or display Samples on site in the manner to facilitate review of qualities indicated. Prepare Samples to match the Architect's sample. Include the following:

- a. Specification Section number and reference.
- b. Generic description of the Sample.
- c. Sample source.
- d. Product name or name of the manufacturer.
- e. Compliance with recognized standards.
- f. Availability and delivery time.

**8.15.2** Submit Samples for review of size, kind, color, pattern, and texture. Submit Samples for a final check of these characteristics with other elements and a comparison of these characteristics between the final submittal and the actual component as delivered and installed.

- a. Where variation in color, pattern, texture, or other character-

istic is inherent in the material or product represented, submit at least three (3) multiple units that show approximate limits of the variations.

- b. Refer to other Specification Sections for requirements for Samples that illustrate workmanship, fabrication techniques, details of assembly, connections, operation, and similar construction characteristics.
- c. Refer to other Sections for Samples to be returned to the Contractor for incorporation in the Work. Such Samples must be undamaged at time of use. On the transmittal, indicate special requests regarding disposition of Sample submittals.
- d. Samples not incorporated into the Work are the property of the Contractor and shall be removed from the site prior to Substantial Completion.

**8.15.3** Preliminary Submittals: Submit a full set of choices where Samples are submitted for selection of color, pattern, texture, or similar characteristics from a range of standard choices, unless otherwise noted in specification section.

- a. The Architect will review and return preliminary submittals with the Architects notation, indicating selection and other action.

**8.15.4** Submittals: Except for Samples illustrating assembly details, workmanship, fabrication techniques, connections, operation, and similar characteristics, submit three (3) sets. The Architect will return one set marked with the action taken.

**8.15.5** Maintain sets of Samples, as returned, at the Project Site, for quality comparisons throughout the course of construction.

**8.15.6** Unless noncompliance with Contract Document provisions is observed, the submittal may serve as the final submittal.

**8.15.7** Sample sets may be used to obtain final acceptance of the construction associated with each set.

**8.15.8** Distribution of Samples: Prepare and distribute additional sets to subcontractors, manufacturers, fabricators, suppliers, installers, and others as required for performance of the Work. Show distribution on transmittal forms.

**8.15.9** Field samples are full-size examples erected on-site to illustrate finishes, coatings, or finish materials and to establish the Project standard.

**8.16 Quality Assurance Submittals:** Submit quality-control submittals, including design data, certifications, manufacturer's instructions, manufacturer's field reports, and other quality-control submittals as required under other Sections of the Specifications.

**8.16.1** Certifications: Where other Sections of the Specifications require certification that a product, material, or installation complies with specified requirements, submit a notarized certification from the manufacturer certifying compliance with specified requirements.

**8.16.2** Signature: Certification shall be signed by an officer of the manufacturer or other individual authorized to sign documents on behalf of the company.

**8.16.3** Inspection and Test Reports: Requirements for submittal of inspection and test reports from independent testing agencies are specified in Division 1 Section "Quality Control".

**8.17 Architect's Action:** Except for submittals for the record or information, where action and return is required, the Architect will review each submittal, mark to indicate action taken, and return promptly.

a. Compliance with specified characteristics is the Contractor's responsibility.

**8.17.1** Action Stamp: The Architect will stamp each submittal with a uniform, action stamp. The Architect will mark the stamp appropriately to indicate the action taken, as follows:

a. Final Unrestricted Release: When the Architect marks a submittal "Approved for fabrication," the Work covered by the submittal may proceed provided it complies with requirements of the Contract Documents. Final payment depends on that compliance.

b. Final-But-Restricted Release: When the Architect marks a submittal "Incorporate Notations," the Work covered by the submittal may proceed provided it complies with notations or corrections on the submittal and requirements of the Contract Documents. Submit corrected copies for record. Final pay-

ment depends on that compliance.

c. Returned for Resubmittal: When the Architect marks a submittal "Rejected, or Revise and Resubmit," do not proceed with Work covered by the submittal, including purchasing, fabrication, delivery, or other activity. Revise or prepare a new submittal according to the notations; resubmit without delay. Repeat if necessary to obtain different action mark.

**8.17.2** Other Action: Where a submittal is for information or record purposes or special processing or other activity, the Architect will return the submittal marked "Action Not Required."

**8.17.3** Unsolicited Submittals: The Architect will discard unsolicited submittals without action.

**8.18** Do not use, or allow others to use, submittals marked "Rejected, or Revise and Resubmit" at the Project Site or elsewhere where Work is in progress.

**8.19** The Contractor shall allow a minimum of two weeks for the Agency and its agents' review of Submittals. No extension of the Contract Time shall be granted for revisions and resubmission. Further, the Contractor shall allow a minimum of eight weeks for testing and acceptance of the Work by the Agency and its agents.

## **Article 9** **EQUALS AND SUBSTITUTIONS**

Definitions in this Article do not change or modify the meaning of other terms used in the Contract Documents.

**9.1** Equals or Substitutions General: Changes in products, materials, equipment, and methods of construction required by the Contract Documents proposed by the Contractor after award of the Contract.

**9.2** Equal: Any deviation from the specification which is defined as follows: A replacement for the specified material, device, procedure, equipment, etc., which is recognized and accepted as substantially equal to the first listed manufacturer or first listed procedure specified, after review, by the Architect and may be rejected or approved at the sole discretion of the owner. All equals must be substantially equivalent to the first manufacturer or first procedure listed in the Specifications with reference to all of the following areas: the substance and function considering quality, workmanship, economy of operation, durability and suitability.

bility for purposes intended; size, rating and cost. The equal does not constitute a modification in the scope of Work, the Schedule or Architect/Engineer's design intent of the specified material, device, procedure, equipment, etc.

**9.3 Substitution:** Any deviation from the specified requirements, which is defined as follows: A replacement for the specified material, device, procedure, equipment, etc., which is not recognized or accepted as equal to the first manufacturer or procedure listed in the Specification after review by the Architect and may be rejected or approved by the Agency. The Substitution is not equal to the specified requirement in comparison to the first manufacture or first procedure listed in the Specifications in one or more of the following areas: the substance and function considering quality, workmanship, economy of operation, durability and suitability for purposes intended; size; cost and rating. The Substitution constitutes a modification in the scope of Work, the Schedule or the Architect/Engineer's design intent of the specified material, device, procedure, equipment, etc.

**9.3.1** The following are not considered to be requests for Equals or Substitutions:

- a. Revisions to the Contract Documents requested by the Agency or Architect.
- b. Specified options of products and construction methods included in the Contract Documents.
- c. The Contractor's determination of and compliance with governing regulations and orders issued by governing authorities having jurisdiction.

**9.4 Submittals: Equals and Substitution Request Submittals:** The Owner will consider requests for equals or substitutions if received within time period of thirty (30) calendar days from the contract award. Requests received more than the days specified will be rejected.

**9.4.1** The Contractor is required to prepare and submit 3 copies of the required data for the first manufacturer listed or procedure listed in the specifications section with reference to all of the following areas: the substance and function considering quality, workmanship, economy of operation, durability and suitability for purposes intended including the size, rating and cost. All submissions must include all the required data for the first listed manufacturer or procedure as specified, as well as the required data for the proposed Equal or Substitution. This will enable the Agency and Architect/Engineer to determine that the proposed Equal or Substitution is or is not substantially equal to the first listed manufacturer or procedure.

**9.4.2** The Contractor is required to identify the product or the fabrication or installation method to be replaced in each request. Include related Specification Section and Drawing numbers.

**9.4.3** The Contractor is required to provide complete documentation showing compliance with the requirements for equals or substitutions, and the following information, as appropriate on a "Substitution Request" form as required by the Agency:

- h. Coordination information, including a list of changes or modifications needed to other parts of the Work and to construction performed by the Agency and separate contractors, that will be necessary to accommodate the proposed Equal or Substitution.
- h. A detailed comparison chart of significant qualities of the proposed substitution with those of the Work specified. Significant qualities may include elements, such as performance, weight, size, durability, and visual effect.
- h. Product Data, including Shop Drawings and descriptions of products and fabrication and installation procedures.
- h. Samples, where applicable or requested.
- h. A statement indicating the effect on the Contractor's Construction Schedule compared to the schedule without approval of the Equal or Substitution. Indicate the effect on overall Contract Time.
- h. Cost information, broken down, including a proposal of the net change, if any in the Contract Sum.
- h. The Contractor's certification that the proposed Equal or Substitution conforms to requirements in the Contract Documents in every respect and is appropriate for the applications indicated.
- h. The Contractor's waiver of rights to additional payment or time that may subsequently become necessary because of the failure of the Equal or Substitution to perform adequately.

**9.5 Architect's/Engineer's Action:** If necessary, the Architect/Engineer will request additional information or documentation for evaluation within one week of receipt of the original request for equal or substitution request. The Architect/Engineer will notify the Construction Administrator who will notify the Agency of recommended acceptance or rejection of the proposed equal or substitution, within two (2) weeks of receipt of the request, or one (1) week of receipt of additional information or documentation, whichever is later. The Construction Administrator will give final acceptance or rejection by the Agency not less than one (1) week after notification.

**9.6** Any request deemed an "Equal" and accepted by the Construction Administrator, Architect, and Agency will result in written notification to the Contractor and will not be in the form of a change order for an "Equal".

**9.7** Any request deemed a "Substitution" and rejected or approved by Construction Administrator, Architect, and Agency may result in written notification to the Contractor and may be in the form of a change order if the "Substitution" is approved.

**9.8 Equal or Substitutions: Conditions:** The Architect will consider the Contractor's request for Equal or Substitution of a product or method of construction when one or more of the following conditions are satisfied, as determined by the Architect. If the following conditions are not satisfied, the Architect will return the requests to the Construction Administrator without action except to record noncompliance with these requirements.

- a. The proposed request does not require extensive revisions to the Contract Documents.
- b. The proposed request is in accordance with the general intent of the Contract Documents.
- c. The proposed request is timely, fully documented, and/or properly submitted. The proposed request can be provided within the Contract Time. However, the Architect will not consider the proposed request if it is a result of the Contractor's failure to pursue the Work promptly or coordinate activities properly.
- d. The proposed request will offer the Agency a substantial advantage, in cost, time, energy conservation, or other considerations, after deducting additional responsibilities the Agency must

assume. However, if the proposed request requires the Owner to incur additional responsibilities, including but not limited to, additional compensation to the Architect for redesign and evaluation services, increased cost of other construction by the Owner or similar considerations, then the Owner will have just cause to reject the request for Equal or Substitution.

- e. The proposed request can receive the necessary approvals, in a timely manner, required by governing authorities having jurisdiction.
- f. The proposed request can be provided in a manner that is compatible with the Work as certified by the Contractor.
- g. The proposed request can be coordinated with the Work as certified by the Contractor.
- h. The proposed request can uphold the warranties required by the Contract Documents as certified by the Contractor.

**9.9** The Contractor's submission and the Architect's review of Submittals, including but not limited to, Samples, Manufacturer's Data, Shop Drawings, or other such items, which are not clearly identified as a request for an Equal or Substitution, will not be considered or accepted as a valid request for an Equal or Substitution, nor does it constitute an approval.

## **Article 10** **SEPARATE CONTRACTS**

**10.1** The Agency reserves the right to perform Work in connection with the Contract with the Agency's own forces, or to let separate contracts relating to the Contract (Project) site or in connection with work on adjoining sites. In such cases, the Contractor shall afford such parties reasonable opportunity for storage of materials and equipment and coordinate and connect the Work with the work on adjoining sites or other projects, and shall fully cooperate with such parties.

**10.2** Contractors working in the same vicinity shall cooperate with one another and, in case of dispute, decision of the Agency shall be final and binding to all Contractors involved, including Contractors under separate Contracts.

**10.3** The Contractor shall assume all liability, financial or otherwise, in connection with this Contract and shall protect and hold harmless the Agency from any and all damages or claims that may arise because of inconvenience or delay which the Contractor may cause other Contractors. If the Contractor experiences a loss because of the presence and operations of other Contractors working adjacent to or within the limits of the same project, then as between the Agency and the Contractor, the Contractor shall bear such loss.

**10.4** Insofar as possible, the Contractor shall arrange the Work and shall place and dispose of the materials being used so as not to interfere with the operations of other Contractors adjacent to or within the limits of the same project. The Contractor shall join its Work with that of others in an acceptable manner, and perform the Work in proper accordance with that of the others.

**10.5** In no event shall the Agency be responsible for any claim or damages that are the result of the Contractor's failure to coordinate the work with any Contractor or Subcontractor.

**Article 11**  
**COOPERATION OF TRADES**

**11.1** The Contractor shall be responsible for and shall control all activities of their Subcontractors. The Subcontractors shall consult and cooperate with one another. Each Subcontractor shall furnish all necessary information to other Subcontractors and shall lay out and install their own Work so as to avoid any delays or interference with the Work of others.

**11.2** Any cost or changes, cutting and/or repairing, made necessary by the failure to observe the above requirements shall be borne by the party or parties responsible for such failure or neglect or their faulty Work installed.

**Article 12**  
**DAMAGES**

**12.1** The Liquidated Damages, provided in the Bidding Documents, will be assessed for each day beyond the date given for Substantial Completion of the Contract according to the Contract Time.

**12.2** The Liquidated Damages or any portion thereof may be waived at the sole discretion of the Agency.

**12.3** No payment by the Agency, either partial or final, shall be construed to waive the Agency's right to seek liquidated damages.

**12.4** In the event a court determines that the contract herein is null and void for any reason, Contractor agrees that Contractor will not seek or pursue any lawsuit or claim for damages, including, but not limited to, claims for loss of overhead or anticipated profits, against the Agency and the Agency shall not be liable for any damages which Contractor may incur as a result of such decision. In addition, if the court enjoins the Agency from entering into or proceeding with the contract herein, the Agency shall not be liable for any damages arising out of or relating to the award of such contract which Contractor may have incurred as a result of the injunction.

**Article 13**  
**MINIMUM WAGE RATES**

In accordance with the provisions of the Connecticut General Statutes Section 31-53, the following applies:

"The wages paid on an hourly basis to any mechanic, laborer or workman employed upon the work herein contracted to be done and the amount of payment or contribution paid or payable on behalf of each such employee to any employee welfare fund, as defined in subsection (h) of section 31-53 of the general statutes, shall be at a rate equal to the rate customary or prevailing for the same work in the same trade or occupation in the town in which such public works project is being constructed. Any contractor who is not obligated by agreement to make payment or contribution on behalf of such employees to any such employee welfare fund shall pay to each employee as part of his wages the amount of payment or contribution for his classification on each pay day."

**Article 14**  
**POSTING MINIMUM WAGE RATES**

**14.1** The Contractor shall post at conspicuous points on the site of the Contract a Schedule showing all determined wage rates for all trades and all authorized deductions, if any, from wages to be paid.

**14.2** The Contractor shall provide weekly certified payrolls to the Agency for all persons working on the site.

**Article 15**  
**CONSTRUCTION SCHEDULES**

**15.1** Unless otherwise specified in the Contract Documents, within seven (7) calendar days from the contract start date, the Contractor shall submit the following to the Agency for approval:

- a. A comprehensive Schedule of Activities. Said schedule shall include Submittal dates, required approval dates and date material must be on site.

**15.2** Within **seven (7) days** of the Agency's issuance of a Contract, the Contractor shall submit to the Construction Administrator **three (3) copies** of a Construction Schedule for this Project. The Schedule shall be in bar chart form and shall include all aspects of the work, the interrelationship of the various trades, and the critical path of the job. The schedule shall include a timeline for the submission, review and approval of shop drawings for critical path items, and delivery and installation dates for those same critical path, or long lead time items, (such as electrical transformers and elevator). The Schedule shall coincide with the Contractor's approved Schedule of Values. The Schedule shall indicate a completion date in advance of the date established for Substantial Completion. The Schedule shall be acceptable to the Architect/Engineer and the Construction Administrator. It shall be revised and reissued at the beginning of every month for the duration of the project. This monthly update progress Schedule shall include a summary comparison of the original schedule and the latest updated schedule (previous month) showing all activity description and dates. These comparison schedules shall be in the form of a summary bar chart, an activity listing report, and actual to target comparisons. The reports shall include critical activities, float time, duration of each activity, dates of each activity, and the network logic (including successors and predecessors of each activity). Included with the written report and copy of the schedule submission, there also shall be a 3- 1/2" computer diskette noting the above referenced requirements. Failure to provide the Architect/Engineer, or the Construction Administrator with an acceptable, revised Schedule, within **seven (7) days** of the receipt of a written request, may result in the withholding of the Contractor's monthly progress payments until such a Schedule is received.

**15.3** Phasing: The Contractor shall include, as part of the Construction Schedule, all proposed phasing for execution of the work. The phasing must incorporate all aspects of the work and shall reflect coordination with any concurrent projects undertaken by Agency, and any partial occupancy requirements of the Agency.

**15.4** Project Schedule Format:

- a. Format: Utilize a horizontal bar chart (ganttt) with a separate bar for each major portion of the Work or operation, identifying first work day of each week.
- b. Program: Use Microsoft Project, latest version.
- c. Sequence of Listings: Utilize the Table of Contents of this Project Manual and the chronological order of the start of each item of work.
- d. Scale and Spacing: Provide space for notations and revisions.
- e. Sheet Size: To be coordinated with Construction Administrator.

**15.5** Quality Assurance: The Contractor's Consultant: Retain a knowledgeable person and/or consultant to provide planning, evaluating, and reporting by CPM scheduling. The Agency may waive the requirement to retain a consultant if the Contractor can demonstrate that:

- a. The Contractor has the computer equipment required to produce construction schedules.
- b. The Contractor employs skilled personnel with experience in construction scheduling and reporting techniques.

**15.6** Computer Program for Project Schedules: Use "Microsoft Project" compatible, latest version.

**15.7** Standards: Comply with procedures contained in AGC's "Construction Planning & Scheduling."

**15.8** Content: Provide the following:

- a. Show complete sequence of construction by activity, with dates beginning and completion of each element of construction.
- b. Identify each item by specification section number.
- c. Identify work of separate phases other and other logically grouped activities.
- d. Show accumulated percentages of completion of each item, and total percentage of Work completed, as of the first day of each month.
- e. Provide separate schedule of submittal dates for shop drawings, product data, and samples, Owner/Agency furnished products and any products identified as under Allowances, and dates reviewed submittals will be required from Architect/Engineer. Indicate decision dates for selection of finishes.
- f. Indicate delivery dates for Agency furnished products and any products identified as under Allowances.
- g. Coordinate content with Schedule of Values.

**15.8.1** Submittals And Revisions To Schedules: Provide the following:

- a. Indicate progress of each activity to date of submittal, and projected completion date of each activity.
- b. Identify activities modified since previous submittal, major changes in scope, other identifiable changes.
- c. Provide narrative report to define problem areas, anticipated delays, and impact on Schedule. Report corrective action taken, or proposed, and its effect.

**15.9** Unless otherwise specified under the Contract Documents, the Contractor shall provide a monthly update of the Construction Schedule in the format required by the Agency as well as a disk of the updated Schedule and program. If, in the opinion of the Agency, the Work is falling behind Schedule, the Contractor shall submit a revised Schedule demonstrating a recovery plan to ensure Substantial Completion of the Work within the Contract Time.

**15.10** Requisitions for partial payment will not be processed until the Contractor has complied with this requirement.

## **Article 16**

### **PREFERENCE IN EMPLOYMENT**

**16.1** Should this Contract be for the construction or repair of any building, then in the employment of labor to perform the Work specified herein, preference shall be given to citizens of the United States, who are, and continuously for at least three (3) months prior to the date hereof, have been residents of the labor market area, as established by the State of Connecticut Labor Commissioner, in which such Work is to be done, and if no such qualified person is available, then to citizens who have continuously resided in the county in which the Work is to be performed for at least three (3) months prior to the date hereof, and then to citizens of the state who have continuously resided in the State at least three months prior to the date hereof.

**16.2** Should this Contract be for a public works project other than for the construction, remodeling or repairing of public buildings covered by Connecticut General Statutes Section 31-52, then in the employment of mechanics, laborers or workmen to perform the Work specified herein, preference will be given to residents of the state who are, and continuously for at least six (6) months prior to the date hereof have been residents of this State, and if not such person is available then to residents of other states.

**16.3** The provisions of this Article shall not apply where the state or any sub-division thereof may suffer the loss of revenue granted or to be granted from any agency or department of the federal government as a result of this Article or regulations related thereto.

## **Article 17**

### **MODIFICATION PROCEDURES**

**17.1** Summary: This Section specifies administrative and procedural requirements for handling and processing contract modifications.

**17.2** Minor Changes in the Work: The Architect, through the Construction Administrator, may issue supplemental instructions authorizing Minor Changes in the Work, not involving adjustment to the Contract Sum or Contract Time, on the "Supplemental Instructions" form as required by the Agency.

**17.3** Proposal Request: The following is the outlined procedure:

- a. Architect/Agency-Initiated Requests For Proposals: The Architect or Agency will issue a detailed description of proposed changes in the Work via the Construction Administrator that will require adjustment to the Contract Sum or Contract Time. If necessary, the description will include supplemental or revised Drawings and Specifications. Such requests

- shall be on a "Proposal Request" form as required by the Agency.
- b. "Proposal Request" is issued for information only. Do not consider them as an instruction either to stop work in progress or to execute the proposed change.
  - c. Within Seven (7) Calendar Days of receipt of a "Proposal Request", submit an "Change Order Proposal" with the required information necessary to execute the change to the Construction Administrator for the Architect's/Agency's review.
  - d. Include a list of quantities of products required and unit costs, with the total amount of purchases to be made. Where requested, furnish survey data to substantiate quantities.
  - e. Indicate applicable delivery charges, equipment rental, and amounts of trade discounts.
  - f. Include a statement indicating the effect the proposed change in the Work will have on the Contract Time.

**17.4** The Agency is tax exempt. All Contractor and Subcontractor services provided under your contract with the State of Connecticut may not be exempt from taxes. The State of Connecticut, Department of Revenue Services can guide you as to which services are exempt and which are not.

- a. The State of Connecticut construction contract has the following tax exemptions:
- b. Purchasing of materials which will be physically incorporated and become a permanent part of the project.
- c. Tools, supplies and equipment used in fulfilling the construction contract are not exempt.
- d. Services that are resold by the contractor are exempt, i.e. if a General Contractor hires a plumber, to be integral and inseparable component parts of the building contract.
- e. Dollar values shown on the Schedule of Values shall not be the governing (or deciding) final amounts for change orders involving either additional charges or deletions.

**17.5** Requests for Information: In the event that the contractor, subcontractor or Construction Administrator, determines that some portion of the drawings, specifications, existing site conditions or other contract documents requires clarification or interpretation by the Architect, then

they shall submit a "Request for Information" in writing to the Architect via Construction Administrator. "Requests for Information" shall be submitted on the "Request for Information" forms as required by the Agency. The "Request for Information", shall clearly and concisely set forth the issue for which clarification or interpretation is sought and why a response is needed from the Architect. The following shall apply:

- a. In the "Request for Information", the writer shall set forth an interpretation or understanding of the requirement along with reasons why such an understanding was reached.
- b. The Agency acknowledges that this is a complex project. Based upon the Agency's past experience with projects of similar complexity, the Agency anticipates that there will probably be some "Requests for Information" on this project.
- c. The Architect will review all "Requests for Information" to determine whether they are "Requests for Information" within the meaning of this term. If it is determined that the document is not a "Request for Information", it will be returned to the contractor, unreviewed as to content, for resubmittal on the proper form and in the proper manner.
- d. A "Requests for Information Response" shall be issued within seven (7) Calendar Days of receipt of the request unless the Agency determines that a longer time is necessary to provide an adequate response. If a longer time is determined necessary by the Agency, the Agency will, within seven (7) Calendar Days of receipt of the request, notify the writer of the anticipated response time. If the contractor submits a "Request for Information" on an activity with seven (7) Calendar Days or less of float on the current project schedule, the contractor shall not be entitled to any time extension due to the time it takes the Architect to respond to the request provided that the Architect responds within the seven (7) Calendar Days set forth above.
- e. A "Requests for Information Response" from Architect will not change any requirement of the contract documents. In the event the contractor believes that the "Requests for Information Response" will cause a change to the requirements of the contract document, the contractor shall immediately give written notice to the Construction Administrator stating that the contractor believes the "Requests for Information Response" will result in "Change Order" and the Contractor intends to submit a "Change Order Proposal" request. Failure to give such written notice immediately shall

waive the contractor's right to seek additional time or cost under the requirement these Requirements.

**17.6 Change Order Proposal:** When either a "Request for Information" from the Contractor or a "Proposal Request" from the Architect or Agency results in conditions that may require modifications to the Contract, the Contractor may propose changes by submitting a request for a "Change Order Proposal" to the Architect via the Construction Administrator on forms as required by the Agency. These forms shall also include "Change Order Proposal Worksheets" as required by the Agency. The following shall apply:

- a. Include statements outlining the reasons for the change and the effect of the change on the Work. Provide a complete description of the proposed change. Indicate the effect of the proposed change on the Contract Sum and Contract Time.
- b. Include a list of quantities of products required and unit costs, with the total amount of purchases to be made. Where requested, furnish survey data to substantiate quantities.
- c. Indicate applicable delivery charges, equipment rental, and amounts of trade discounts.
- d. Comply with requirements in Equals and Substitutions if the proposed change requires an equal or substitution of one product or system for a product or system specified.

**17.7 "Change Order Request" Forms:** Use "Change Order Proposal" and "Change Order Proposal Worksheets" forms as required by Agency.

**17.8 Construction Change Directive:** When the Agency and the Contractor disagree on the terms of a "Change Order Proposal" resulting from either a "Request for Information" or "Proposal Request", then the Architect through the Construction Administrator may issue a "Construction Change Directive" on a "Construction Change Directive" as authorized by the Agency on the form required by the Agency. The "Construction Change Directive" instructs the Contractor to proceed with a change in the Work, for subsequent inclusion in a "Change Order".

**17.8.1** The "Construction Change Directive" contains a complete description of the change in the Work. It also designates the method to be followed to determine change in the Contract Sum or Contract Time. The Contractor shall maintain detailed records on a time and material basis of work required by the "Construction Change Directive".

After completion of the change, submit an itemized account and supporting data necessary to substantiate cost and time adjustments to the Contract. The final value shall be negotiated based on the supporting data to determine the value of the work.

**17.9 Change Order Procedures:** Upon the Agency's approval of a Contractor's "Change Order Proposal", the Construction Administrator will issue a "Change Order" for signatures of the Architect, Agency and the Contractor on "Change Order" form as required by the Agency.

### **Article 18** **COMPENSATION FOR CHANGES** **IN THE WORK**

**18.1** At any time, without invalidating the Contract and by a written order and without notice to the sureties, the Agency, through the Construction Administrator, may order modifications in the Work consisting of additions, deletions or other revisions. Upon request, the Contractor shall supply the Construction Administrator promptly with a detailed proposal for the same, showing quantities of and unit prices for the Work and that of any Subcontractor involved.

**18.2** Modifications to the Work will be authorized by a written Change Order, or if necessary to expedite the Work, a written Construction Change Directive. Change Orders and Construction Change Directives shall be processed in accordance with the terms of the Contract Documents. Upon receipt of the written Change Order, the Contractor shall proceed with the Work when and as directed.

**18.3** If such Change Orders make the Work less expensive for the Contractor, the proper deductions shall be made from the Contract Sum, said deductions to be computed in accordance with the provisions listed in this Article 18.

**18.4** The Contractor and the Agency agree that the Contract Time specified for the performance of the Contract shall include not only the Work of the original Contract but also any Additional Work ordered by the Agency by Change Order. No extension of time will be granted if it is the opinion of the Agency that the additional Work can be performed concurrently with the original Work.

**18.5** The Contractor may request, and the Agency may grant additional contract time when, in the opinion of the Agency, the Contractor has demonstrated that such additional work cannot be performed concurrently with the original Work.

**18.6** The amount of compensation to be paid to the Contractor for any Additional or Deleted Work that results in a

Change Order shall be determined in one of the following manners:

**18.6.1 AMOUNT OF COMPENSATION FOR CHANGE ORDER COSTS: LABOR, EQUIPMENT, BENEFITS AND MATERIAL**

**18.6.1.1** Unit Price: As stated in the Contract Documents.

**18.6.1.2** Unit Price: As subsequently agreed upon by the Contractor and Agency.

**18.6.1.3** Lump Sum: Agreed upon sum by the Agency and the Contractor. The Lump Sum must be based upon the following itemized costs:

**18.6.1.3.1** Labor (Contractor's or Subcontractor's own forces).

**18.6.1.3.2** Material (Used by Contractor's or Subcontractor's own forces).

**18.6.1.3.3** Benefits: (The established rates of the following benefit costs inherent to the particular labor involved):

**18.6.1.3.3.1** Workers Compensation.

**18.6.1.3.3.2** Federal Social Security.

**18.6.1.3.3.3** Connecticut Unemployment Compensation.

**18.6.1.3.3.4** Fringe Benefits.

**18.6.1.3.4** Rented Equipment (Used directly on the Work and by the Contractor's or Subcontractor's own forces).

**18.6.1.3.5** Owned Equipment (Used directly on the Work and by the Contractor's or Subcontractor's own forces). Daily rate is not to exceed 3% of the monthly rental rate as identified by a nationally recognized construction cost estimating guide or service.

**18.6.1.3.6** Trade related equipment, hand tools and power tools, normally supplied with the labor are not compensable.

**18.6.2 OVERHEAD AND PROFIT PERCENTAGES:** (Maximum allowable percentages applied to labor, equipment, benefits and material).

**18.6.2.1** Contractor's markup for Work performed by their own forces:

<b>Change Order Amount</b>	<b>Overhead and Profit</b>
\$0 to \$ 5,000	20%
\$5,001 to \$15,000	17%

\$15,001 to \$25,000	15%
\$25,000 and greater	12%

**18.6.3 OVERHEAD AND PROFIT PERCENTAGES:** (Maximum allowable percentages applied to labor, equipment, benefits and material).

**18.6.3.1** Contractor's markup for Work performed by their Subcontractors forces:

<b>Change Order Amount</b>	<b>Overhead and Profit</b>
\$0 and greater	6%

**18.6.4 OVERHEAD AND PROFIT PERCENTAGES:** (Maximum allowable percentages applied to labor, equipment, benefits and material).

**18.6.4.1** Subcontractor's markup for Work performed by their own forces:

<b>Change Order Amount</b>	<b>Overhead and Profit</b>
\$0 to \$ 5,000	20%
\$5,001 to \$15,000	17%
\$15,001 to \$25,000	15%
\$25,000 and greater	12%

**18.6.5 OVERHEAD AND PROFIT PERCENTAGES:** (Maximum allowable percentages applied to labor, equipment, benefits and material).

**18.6.5.1** Subcontractor's markup for Work performed by their Secondary Subcontractor's forces.

<b>Change Order Amount</b>	<b>Overhead and Profit</b>
\$0 and greater	6%

**18.7** Actual additional bonding costs associated with the value of the Change Order will be compensable only when supported by a written documentation by the bonding company that the Change Order requires an increase to the original Performance, Payment, Labor or Material Bond. Such claims shall be held and calculated at the end of construction activities and to be included under Final Payment.

**18.8** If Unit Prices are not applicable and the parties cannot agree upon a lump sum, then the Agency, through the Construction Administrator take the following action(s):

**18.8.1** Issue a Construction Change Directive for the Additional or deleted Work. The amount of compensation shall be computed by the actual net costs to the Contractor based upon the following:

**18.8.1.1** Labor (Contractor's or Subcontractor's own forces).

**18.8.1.2** Material (Used by Contractor's or Subcontractor's own forces).

**18.8.1.3** Benefits: (The established rates of the following benefit costs inherent to the particular labor involved):

- 18.8.1.3.1** Workers Compensation.
- 18.8.1.3.2** Federal Social Security.
- 18.8.1.3.3** Connecticut Unemployment Compensation.
- 18.8.1.3.4** Fringe Benefits.

**18.8.1.4** Rented Equipment (Used directly on the Work and by the Contractor's or Subcontractor's own forces).

**18.8.1.5** Owned Equipment (Used directly on the Work and by the Contractor's or Subcontractor's own forces). Daily rate is not to exceed 3% of the monthly rental rate that can be identified by a nationally recognized construction cost estimating guide or service.

**18.8.2** Issue a Change Order adjusting the Contract Sum in the amount as determined by the Agency.

**18.9** For any Change Order or Construction Change Directive the Contractor shall, when requested, promptly furnish in a form satisfactory to the Construction Administrator and the Agency a complete detailed accounting of all costs relating to the Additional Work, including but not limited to certified payrolls and copies of accounts, bills and vouchers to substantiate actual costs. Further, the Agency reserves the right to access and make copies of the Contractor's records at any time upon written request to the Contractor.

**18.10** If the Contractor wishes to make a claim for an increase in the Contract Sum for any damages sustained as a result of Additional Work, then the Contractor shall give the Agency, through the Construction Administrator, written notice thereof within seven (7) calendar days after the occurrence of the event giving rise to such claims.

**18.11** No such claims shall be valid if the written notice is submitted after the required seven (7) calendar days. In addition, the Contractor shall file with the Agency, through the Construction Administrator, daily or weekly itemized statements of the details and cost of such Work performed or damage sustained as may be required by the Agency.

**18.12** Failure of the Contractor to negotiate in good faith issues of time and costs and failure to provide requested documentation within (14) fourteen calendar days, or a time period accepted by the Agency, shall constitute a waiver by the Contractor of any claim. In such cases the Agency may elect to issue a unilateral Change Order in an amount deemed to be fair and equitable by the Agency. The provisions hereof shall not affect the power of the Contractor to act in case of emergency, threatened injury to persons, or damage to Work on any adjoining property. In this case the Agency, through the Construction Administrator, shall issue a written order for such amount as the Agency finds to be reasonable cost of such Work.

## **Article 19** **DELETED WORK**

**19.1** Without invalidating any of the terms of the Contract, the Agency may order deleted from the Contract any items or portions of the Work deemed necessary by the Agency.

**19.2** The compensation to be deducted from the Contract Sum for such deletions shall be determined in the manner provided for under the provisions of Article 13 or in the event none of the provisions of Article 13 are applicable than by the value as estimated by the Agency.

## **Article 20** **MATERIALS: STANDARDS**

**20.1** Unless otherwise specifically provided for in the Specifications, all equipment, materials and articles incorporated in the Work are to be new and of the best grade of their respective kinds for the purposes. Wherever in the Contract Documents a particular brand, make of material, device, or equipment is shown or specified, the first manufacturer listed in the specification section is to be regarded as the standard. When the specification is proprietary and only one manufacturer is listed, the Contractor shall use the named manufacturer and no Substitutions or Equals will be allowed.

**20.2** Any other brand, make of material, device, equipment, procedure, etc. which is a deviation from the specified requirement is prohibited from use but may be considered by the Agency for approval as an Equal or Substitution. The Contractor is to adhere to the specific requirements of the Contract Documents. Substitutions are discouraged and are only approved by the Agency as an exception.

**20.3** Each request for an Equal or Substitution shall be submitted, with the appropriate documentation, as detailed in the Contract Documents, to the Construction Administrator. All requests will be compared to the first manufacturer or first procedure listed in the specific Specification section with reference to all of the following areas: the substance and function considering quality, workmanship, economy of operation, durability and suitability for purposes intended including the size, rating and cost. All submissions must include all the required data for the first listed manufacturer or procedure as specified, as well as the proposed Equal or Substitution. The submission of all Equals or Substitutions to those specified must be made within the days listed below after the contract start date. After that time period, the Contractor shall provide what is specified unless otherwise allowed within the sole discretion of the Agency.

**20.3.1** 30 days for projects having a Contract Time duration of 180 days or less.

**20.3.2** 60 days for projects having a Contract Time duration of 181 days to 360 days.

**20.3.3** 90 days for projects having a Contract Time duration of 361 days or greater.

**20.4** Contractor shall submit each request for Equal or Substitution to the Architect who shall review each request and make the following recommendations to the Agency:

**20.4.1** Acceptance or non-acceptance of the adequacy of the submission and required back-up,

**20.4.2** Determination of the category of the request for Substitution or Equal, and

**20.4.3** Overall recommendation for approval or rejection of the Substitution or Equal. The determination of the category as a Substitution may be grounds for an immediate rejection by the Agency.

**20.5** Approval of the Agency, for each Equal or Substitution shall be obtained before the Contractor proceeds with the Work. The decision of the Agency, in this regard, shall be final and binding on the Contractor.

**20.6** No extension of time will be allowed for the time period required for consideration of any Substitution or Equal. No extension of time will be allowed and no responsibility will be assumed by the Agency when a Contractor submits a request for Substitution or Equal, whether such request be approved or denied.

**20.7** If the Contractor submits any request for an Equal or a Substitution, he shall bear the burden of proof that such requested Equal or Substitution meets the requirements of the plans and specifications.

**20.8** The Contractor shall purchase no materials or supplies for the Work which are subject to any chattel mortgage or which are under a conditional sale or other agreement by which an interest is retained by the seller. The Contractor warrants that the Contractor has good title to all materials and supplies used by him in the Work.

**20.9** All Products and systems supplied to the State as result of a purchase by a contractor shall be certified that, to the best of the supplier's knowledge there are no materials that are classified as hazardous materials being used within the assembly. Hazardous materials include, but are not limited to, products such as asbestos, lead and other materials that have proven to cause a health risk by their presence.

specified elsewhere in the Contract Documents and required by authorities having jurisdiction. All tests required by the individual specification sections are required to be scheduled and notification given to the Construction Administrator forty-eight (48) hours in advance to the test/inspection as applicable.

**21.2** Where individual Sections specifically indicate that certain inspections, tests, and other quality-control services are the Contractor's responsibility, the Contractor shall employ and pay a qualified independent testing agency to perform quality-control services. Costs for these services are included in the Contract Sum.

**21.3** Where individual Sections specifically indicate that certain inspections, tests, and other quality-control services are the Agency's responsibility, the Owner will employ and pay a qualified independent testing agency to perform those services. Such services include Special Inspections as required by the latest adoption of the "Connecticut State Building Code".

**21.4** Where the Agency has engaged a testing agency for testing and inspecting part of the Work, and the Contractor is also required to engage an entity for the same or related element, the Contractor shall not employ the entity engaged by the Owner. The Agency will engage the services of a qualified Special Inspector for this project. The Special Inspector, as a representative of the Agency, shall document and confirm compliance with the provisions of the Connecticut State Building Code for Special Inspections.

**21.5** Materials and assemblers for this project will be tested and construction operations inspected as the work progresses. Failure to detect any defective work or material shall not in any way prevent later rejection when such defect is discovered nor shall it obligate the State for final acceptance.

**21.6** The Agency use of testing and inspection services shall in no way relieve the contractor of the responsibility to furnish materials and finished construction in full compliance with the Contract Documents and the Connecticut State Building Codes.

## **Article 21** **QUALITY CONTROL**

**21.1** Contractor Responsibilities: Unless otherwise indicated as the responsibility of another identified entity, the Agency, through the Construction Administrator, shall provide inspections, tests, and other quality-control services

**21.7 Retesting:** The Contractor is responsible for retesting where results of inspections, tests, or other quality-control services prove unsatisfactory and indicate noncompliance with Contract Document requirements, regardless of whether the original test was Contractor's responsibility.

**.7.1** The cost of retesting construction, revised or replaced by the Contractor, is the Contractor's responsibility where required tests performed on original construction indicated noncompliance with Contract Document requirements.

**21.7.2** The Agency will issue a credit change order to cover all costs incurred related to all re-tests/re-inspection due to non-compliance to the contract documents, including but not limited to the Agency's costs and the Consultants costs.

**21.8 Associated Services:** Cooperate with agencies performing required inspections, tests, and similar services, and provide reasonable auxiliary services as requested. Notify the agency sufficiently in advance of operations to permit assignment of personnel. Auxiliary services required include, but are not limited to, the following:

- a. Provide access to the Work.
- b. Furnish incidental labor and facilities necessary to facilitate inspections and tests.
- c. Take adequate quantities of representative samples of materials that require testing or assist the agency in taking samples.
- d. Provide facilities for storage and curing of test samples.
- e. Deliver samples to testing laboratories.
- f. Provide an approved design mix proposed for use for material mixes that require control by the testing agency.
- g. Provide security and protection of samples and test equipment at the Project Site.

**21.9 Duties of the Testing Agency:** The independent testing agency engaged to perform inspections, sampling, and testing of materials and construction specified in individual Sections shall cooperate with the Construction Administrator, Architect and the Contractor in performance of the testing agency's duties. The testing agency shall provide qualified personnel to perform required inspections and tests.

**21.9.1** The testing agency shall notify the Construction Administrator and the Contractor promptly of irregularities or deficiencies observed in the Work during performance of its services.

**21.9.2** The testing agency is not authorized to release, revoke, alter, or enlarge requirements of the Contract Documents or approve or accept any portion of the Work.

**21.9.3** The testing agency shall not perform any duties of the Contractor.

**21.10** Agency will pay for the services of an independent testing agency laboratory to perform inspections, tests and other services required by the Specifications except as noted below, listed for which the Owner will issue a deduct change order to cover the cost associated with these tests:

- a. When the Contractor notifies the Construction Administrator and/or Testing Agency less than twenty-four (24) hours before the expected time of testing.
- b. When the Contractor requires testing for his own convenience.
- c. When the Contractor schedules a test and is not ready for the required test.

**21.11** Fire Alarm/Acceptance Testing Procedures: The Contractor shall follow the "Acceptance Testing Procedures" as provided by the Agency prior to Acceptance Testing.

**21.11.1** Submittals: Unless the Contractor is responsible for this service, the independent testing agency shall submit a certified written report, in duplicate, of each inspection, test, or similar service to the Construction Administrator. If the Contractor is responsible for the service, submit a certified written report, in duplicate, of each inspection, test, or similar service through the Contractor.

**21.11.2** Submit additional copies of each written report directly to the governing authority, when the authority so directs.

**21.11.3** Report Data: Written reports of each inspection, test, or similar service include, but are not limited to, the following:

- a. Date of issue.
- b. Project title and number.
- c. Name, address, and telephone number of testing agency.
- d. Dates and locations of samples and tests or inspections.
- e. Names of individuals making the inspection or test.
- f. Designation of the Work and test method.
- g. Identification of product and Specification Section.
- h. Complete inspection or test data.
- i. Test results and an interpretation of test results.
- j. Ambient conditions at the time of sample taking and testing.
- k. Comments or professional opinion on whether inspected or tested Work complies with Contract Document requirements.
- l. Name and signature of laboratory inspector.
- m. Recommendations on re-testing.

**21.12** Quality Assurance: Engage inspection and testing service agencies, including independent testing laboratories, that are pre-qualified as complying with the National Voluntary Laboratory Accreditation Program and that specialize in the types of inspections and tests to be performed.

**21.12.1** Each independent inspection and testing agency engaged on the Project shall be authorized by authorities having jurisdiction to operate in the state where the Project is located.

**21.13** Repair and Protection: Upon completion of inspection, testing, sample taking and similar services, repair damaged construction and restore substrates and finishes. Comply with Contract Document requirements for Division 1 Section "Cutting and Patching."

**21.13.1** Protect construction exposed by or for quality-control service activities, and protect repaired construction.

**21.13.2** Repair and protection is Contractor's responsibility, regardless of the assignment of responsibility for inspection, testing, or similar services.

## **Article 22** **INSPECTION AND TESTS**

**22.1** The purpose of the inspections will be to assure that the Work is performed in accordance with the Contract Documents. These inspections shall include, but not be limited to all inspections and testing as required by the Agency, and any authorities have jurisdiction.

**22.2** All material and workmanship, if not otherwise designated by the Specifications, shall be subject to inspection, examination and test by the Agency at any and all times during manufacture and/or construction and at any and all places where such manufacture and/or construction is carried on. The Contract Documents additionally identify the parties responsible for performing and paying for the required testing and inspections. All required tests performed in a laboratory will be obtained and paid for by the Agency except when the tests show the Work to be defective. The Contractor shall pay for all the costs associated with re-tests and re-inspections for all tests and inspections which fail. The Agency will issue a deduct Change Order to recover said retesting costs from the Contractor. All other tests, unless otherwise specified, shall be made at the Contractor's expense. Notice of the time of all tests to be made at the site shall be given to all interested parties, including the Agency.

**22.3** Without additional cost to the Agency, the Contractor shall promptly furnish facilities, labor and materials necessary to coordinate and perform operational tests and check-out of the Work. The Contractor shall furnish promptly all reasonable facilities, labor and materials necessary to make all such testing safe and convenient.

**22.4** If, at any time before Final Completion and Final Acceptance of the Work, the Agency considers it necessary or advisable to examine of any portion of the Work already completed by removing or tearing out the same, the Contractor shall, upon request, furnish promptly all necessary facilities, labor and materials. If such Work is found to be defective in any material respect, as determined by the Agency, because of a fault of the Contractor or any of the

Contractor's Subcontractors, or if any Work shall have been covered without the approval or consent of the Agency or its representatives (whether or not it is found to be defective), the Contractor shall be liable for testing costs and all costs of correction, including removal and/or demolition of the defective work, including labor, material, and testing, including labor, material, re-testing or re-inspecting, services of required consultants, additional supervision, the Agency's and the Construction Administrator's administrative costs, and other costs for services of other consultants.

**Article 23**  
**ROYALTIES AND PATENTS**

**23.1** If the Contractor desires to use any design, device, material or process covered by a patent or copyright, the Contractor shall provide for such use by suitable legal agreement with the holder of said patent or copyright. The Contractor shall furnish a copy of this legal agreement to the Agency.

**23.2** The Contractor shall indemnify and hold harmless the Agency and Construction Administrator for any costs, expenses and damage which it may be obliged to pay by reason of any infringement of a patent or a copyright, at any time during the prosecution or after the Final Completion of the Work.

**Article 24**  
**SURVEYS, PERMITS AND REGULATIONS**

**24.1** Unless otherwise provided for, the Contractor shall furnish surveys necessary for the execution of the Work. The Agency will furnish the Contractor with two base lines and a benchmark.

**24.2** The Contractor shall obtain and pay for permits and licenses necessary for the execution of the Work and the occupancy and use of the completed Work.

**24.3** The Contractor shall give all notices and comply with all laws, ordinances, rules and regulations including building and fire safety codes relating to the performance of the Work.

**24.4** If underground utilities may involve part of the Work, the Contractor shall obtain the services of a qualified underground utility locating firm, at no cost to the Agency, to verify locations of underground utilities, to provide safety, protect the Work and protect the workmen as necessary to perform the Work.

**Article 25**  
**PROTECTION OF THE WORK,  
PERSONS AND PROPERTY**

**25.1** The Contractor shall continuously and adequately protect the Work against damage from any cause, and shall protect materials and supplies furnished by the Contractor or Subcontractors, whether or not incorporated in the Work, and shall make good any damage unless it be due directly to errors in the Contract Documents or is caused by agents or employees of the Agency.

**25.2** To the extent required by law, by public authority, or made necessary in order to safeguard the health and welfare of the personnel or occupants of any of the state institutions, the Contractor shall adequately protect adjacent property and persons, and provide and maintain all facilities, including but not limited to passageways, guard fences, lights, and barricades necessary for such protection.

**25.3** The Contractor shall take all necessary precautions for the safety of employees on the Work and shall comply with applicable provisions of federal and state safety laws and building codes to prevent accidents or injury to persons on, about or adjacent to the premises where the Work is being performed. The Contractor shall also comply with the applicable provisions of the Associated General Contractors' "Manual of Accident Prevention in Construction", and the standards of the Connecticut Labor Department and Occupational Safety and Hazard Association (OSHA).

**25.4** The Contractor shall erect and properly maintain at all times, as required by the conditions and progress of the Work, all necessary safeguards for the protection of employees of the State and the public, and shall post danger signs warning against any dangerous condition or hazard created by such things as protruding nails, well holes, elevator hatchways, scaffolding, window openings, excavations, tripping hazards or slipping, stairways and falling materials.

**25.5** The Contractor shall designate a qualified and responsible on site staff person, whose duty shall be the prevention of accidents. The name and position of the designated person shall be reported to the Agency by the Contractor at the commencement of the Contract.

**25.6** The Contractor shall at all times protect excavation, trenches, buildings and all items of Work from damage by rain, water from melted snow or ice, surface water run off and subsurface water usual for the vicinity at the time of operations; and provide all pumps and equipment and enclosures to insure such protection.

**25.7** The Contractor shall construct and maintain all necessary temporary drainage and do all pumping necessary to keep excavation, basements, footings and foundations free of water.

**25.8** The Contractor shall remove all snow and ice as may be required for access to the site and proper protection and prosecution of the Work.

**25.9** The Contractor shall install bracing, shoring, sheathing, sheet piling, caissons and any other underground facilities as required for safety and proper execution of the Work, and shall remove this portion of the Work when no longer necessary.

**25.10** During cold weather the Contractor shall protect all Work from damage. If low temperature makes it impossible to continue operations safely in spite of cold weather precautions, the Contractor may cease Work upon the written approval of the Agency.

**Article 26**  
**TEMPORARY UTILITIES**

**26.1** Unless expressly provided for otherwise in the Contract Documents, the Contractor shall include in the bid the costs of all temporary utilities required for project completion and protection of the Work. Said temporary utilities include but are not limited to lighting, heating, cooling, electrical power, water, telephone, sanitary facilities, and potable water.

**Article 27**  
**CORRECTION OF WORK**

**27.1** The Contractor shall promptly and without expense to the Owner remove from the premises all materials rejected by or unacceptable to the Construction Administrator as failing to conform to the Contract Documents, whether incorporated in the Work or not.

**27.2** The Contractor shall promptly and without expense to the Owner replace any such materials which do not conform to the Contract Documents, and shall bear the expense of making good all Work of other Contractors or Subcontractors destroyed or damaged by such removal or replacement.

**27.3** If the Contractor, after receipt of notice from the Agency, shall fail to remove such rejected or unacceptable materials within a reasonable time as fixed in said notice, the Owner may remove and store such materials at the expense of the Contractor.

**27.4** Such action shall not affect the obligation of the Contractor to replace and complete assembly and installation of the Work and to bear the expenses referred to above. Prior to the correction of rejected or unacceptable Work or if the Agency deems it inexpedient or undesirable to correct any portion of the Work which was rejected, deemed unacceptable or not done in accordance with the Contract Doc-

uments, the Contract sum shall be reduced by such amount as, in the judgment of the Agency, shall be equitable.

**27.5** No extension of time will be given to the Contractor for correction of rejected or unacceptable Work. All significant punchlist Work shall be completed before Substantial Completion is determined. The remaining minor punchlist Work, as determined by the Agency, shall be completed within 60 days of established Substantial Completion date.

**27.6** Final Payment shall not relieve the Contractor of responsibility for the defects in material or workmanship.

**27.7** Unless expressly provided for otherwise in the Contract Documents, the Contractor shall remedy any rejected or unacceptable Work, and any Work found to be not conforming to the Contract Documents which is discovered within 18 Months after the date of Substantial Completion. The Contractor shall pay for any damage to other Work caused by such nonconforming Work or any damage created in correcting the nonconforming Work.

**Article 28**  
**STARTING SYSTEMS**

**28.1 General:** The Contractor shall provide the following:

- a. Coordinate schedule for start-up of various equipment and systems with the Construction Administrator and Agency.
- b. Provide written notification to the Construction Administrator fourteen (14) Calendar Days prior to start-up of each item.
- c. Verify that each piece of equipment or system has been checked for proper lubrication, drive rotation, belt tension, and control sequence for other conditions that may cause damage.
- d. Verify that tests, meter readings, and specified electrical characteristics agree with those required by the equipment or system manufacturer.
- e. Verify in wiring and support components are complete and tested.
- f. Execute the start-up under supervision of manufacturer's representative, in accordance with manufacturer's instructions.
- g. When referenced in individual specification sections, require manufacturer to provide an authorized representative to be present at the site to inspect, check, and approve equipment or system installation prior to start-up, and to supervise placing equipment or system in operation.
- h. Submit a written report that the equipment or system has been properly installed and is functioning properly.

**28.2 Demonstration and Instructions:** The Contractor shall provide the following:

- a. Demonstrate operation and maintenance of Products to Architect/Engineer and Agency Personnel two (2) weeks prior to substantial completion. Provide a VHS type video record of all demonstrations.
- b. Demonstrate Project equipment and instruct in a classroom environment at location designated by the Construction Administrator and instructed by a qualified manufacturer's representative who is knowledgeable about the project.
- c. For equipment or systems requiring seasonal operation perform demonstration for season within six (6) months.

- d. Utilize operation and maintenance manuals as basis for instruction. Review contents of manual with Architect/Engineer and Agency Personnel in detail to explain all aspects of operation and maintenance.
- e. Demonstrate start-up, operation, control, adjustment, troubleshooting, servicing, and maintenance, and shutdown of each item at agreed upon scheduled time and at equipment or designated location.
- f. Prepare and insert additional data in operations and maintenance manuals when need for additional data becomes apparent during demonstration.

**28.3 Testing Adjusting, and Balancing:** The Contractor will employ and pay for the testing services of an independent consultant to verify the testing, adjusting, and balancing.

**28.3.1** Reports will be submitted by the independent testing consultant to the Construction Administrator indicating observations and results of tests and indicating compliance or non-compliance with the requirements of the Contract Documents.

**28.3.2** The Agency may employ and pay for the services of an independent consultant to verify testing, adjusting, and balancing which was performed by the Contractor.

#### **Article 29**

#### **GUARANTEES and WARRANTIES**

**29.1** Unless expressly provided for otherwise in the Contract Documents, the Contractor shall provide a warranty on the Work for an 18-Month period from the date of Substantial Completion. The Contractor shall warrant that the equipment, materials and workmanship are of good quality and new, unless permitted elsewhere by the Contract Documents, and that the Work shall be free from defects not inherent in the quality required or permitted and that the Work conforms to the Contract Documents.

**29.2** Disclaimers and limitations from manufactures, Subcontractors, suppliers or installers to the Contractor shall not relieve the Contractor of the Warranty on the Work. The Contract Documents detail the related damages, reinstatement of warranty, replacement cost and Agency's recourse.

#### **Article 30**

#### **CUTTING, FITTING, PATCHING AND DIGGING**

**30.1** The Contractor will perform or will cause the Subcontractors to perform all cutting, fitting or patching of the portion(s) of the Work that may be required to make the

several parts thereof joined and coordinated in a manner satisfactory to the Agency and in accordance with the Plans and Specifications.

**30.2** The responsibility for defective or ill-timed Work shall be with the Contractor, but such responsibility shall not in any way relieve the Subcontractor who performed such Work. Except with the consent of the Agency, neither the Contractor nor any of its Subcontractors shall cut or alter the Work of any other Contractor or Subcontractor.

**Article 31**  
**CLEANING UP**

**31.1** The Contractor shall, on a daily basis, keep the premises free from accumulations of waste material or rubbish.

**31.2** Prior to Final Completion of the Work, the Contractor shall remove from and about the site of the Work, all rubbish and all temporary structures, tools, scaffolding and surplus materials, supplies and equipment which may have been used in the performance of the Work. If the Agency in their sole discretion determines that the Contractor has failed to clean the work site, the Agency may remove the rubbish and charge the cost of such removal to the Contractor. A deduct Change Order will be issued by the Agency to recover such cost.

**Article 32**  
**ALL WORK SUBJECT TO CONTROL OF THE AGENCY**

**32.1** The Agency hereby declares that only authorized representatives may act in matters involving the Agency's or Architect's ability to revoke, alter, enlarge or relax any requirement of the Contract Documents; to settle disputes between the Contractor and the Construction Administrator; and act on behalf of the Agency. In all such matters, the provisions of Articles 13 and 14 herein shall guide the Agency.

**32.2** In no event may the Contractor act on any instruction of the Agency without written consent of the Agency. In the event the Contractor acts without such consent, he does so at his own risk and at his own expense, not only for the Work performed, but for the removal of such Work as determined necessary by the Agency.

**32.3** In the performance of the work, The Contractor shall abide by all orders, directions, and requirements of the Agency at such time and places and by such methods and in such manner and sequence as the Agency may require.

**32.4** The Agency shall determine the amount, quality, acceptability and fitness of all parts of the work, shall interpret the plans, specifications, Contract Documents and ex-

tra work orders and shall decide all other questions in connection with the Work.

**32.5** The Contractor shall employ no plant, equipment, materials, methods or persons to which the Agency objects and shall remove no plant materials, equipment or other facilities from the site of the Work without the permission of the Agency.

**Article 33**  
**CONSTRUCTION ADMINISTRATOR**

**33.1** The Construction Administrator employed by the Agency is authorized to inspect all Work for conformance to the Contract Documents. The Construction Administrator is authorized to reject all Work found to be defective, unacceptable and nonconforming to the Contract Documents. Such inspections and rejections may extend to all or any part of the Work, and to the preparation or manufacture of the material to be used.

**33.2** The Construction Administrator is not empowered to revoke, alter, enlarge or relax any requirements of the Contract Documents, or to issue instructions contrary to the Contract Documents. The Construction Administrator shall in no case act as foreman or perform other duties for the Contractor, nor shall the Construction Administrator interfere with the management of the Work by the Contractor. Any advice, which the Construction Administrator may give the Contractor, shall in no way be construed as binding the Agency in any way, nor releasing the Contractor from the fulfillment of the terms of the Contract.

**33.3** In any dispute arising between the Contractor and the Construction Administrator with reference to inspection and rejection of the Work, the Construction Administrator may suspend work on the noncompliant portion of the Work until the dispute can be referred to and decided by the Agency.

**33.4** The Construction Administrator is referred to in the Contract Documents as "Construction Administrator" or "Construction Manager" or by pronouns which imply it. All communications concerning the project will be directed through the Construction Administrator or a designated representative(s).

**33.5** The Construction Administrator is the Agency's Agent who will, among other things, monitor the Project including Contractor's performance, scheduling and construction, process shop drawings, material, and equipment submittals, review and process periodic billings, review and recommend cost changes.

**33.6** The Construction Administrator will process all requests for information, interpretations and decisions regard-

ing the meaning and intent of the Contract Documents, consulting with appropriate parties prior to rendering the interpretations or decisions to the Contractor. All such requests and replies shall be in writing.

**Article 34**  
**SCHEDULE OF VALUES,**  
**APPLICATION FOR PAYMENT**

**34.1** Immediately after the signing of the Contract, the Contractor shall furnish for the use of the Agency as a basis for estimating partial payments, a certified Schedule of Values, totaling the contract sum and broken down into quantities and unit costs, as outlined in the Contract Documents and as directed by the Agency. The Schedule of Values must reflect true costs and be in sufficient detail to be an effective tool for monitoring the progress of the Work. Upon request of the Agency, the Contractor shall supply copies of signed Contracts, vendor quotations, etc. as back up to the Schedule of Values.

**34.2** Submit the "Schedule of Values" to the Construction Administrator at the earliest possible date but no later than (7) seven Calendar Days after the Contract Award. The Schedule of Values is the basis for estimating partial payments. The Contractor shall furnish for the approval of the Construction Administrator and Architect, an accurate and certified Schedule of Values, broken down into quantities and unit costs for the various parts of the Work. The breakdown shall include a complete definition of all activities, systems and components that form the project. The use of lump sum or grouping of activities shall not be allowed without the written consent of the Construction Administrator. It shall be CAD generated, in a format provided by the Construction Administrator, divided as may be directed and it shall aggregate the total sum of the Contract. Also include a 3-1/2" computer diskette of the original and revised schedule to the Construction Administrator. If requested, the Contractor shall submit evidence supporting this Schedule.

**34.3** A separate "Schedule of Value" shall be provided for each Phase as identified in the Supplementary General Conditions and General Requirements - Section 01010 Summary of Work, Work Sequence - Phase(s).

**34.4** Use the Project Manual Table of Contents as a guide to establish the format for the "Schedule of Values". Provide at least one line item for each of the Specification Section on electronic media printout.

**34.5** Identification: Project identification on the Schedule of Values shall include, but not be limited to, the following:

- a. Owner
- b. Project Number
- c. Project Name
- d. Project Location
- e. Contractor's name and address.

**34.6** Arrange the "Schedule of Values" in tabular format as required by the Agency, containing separate columns including, but not limited to, the following Items:

- a. Item Number.
- b. Description of Work with Related Specification Section or Division Number.
- c. Scheduled Values broken down by description number, type material, units of each material.
- d. Name of subcontractor.
- e. Name of manufacturer or fabricator.
- f. Name of supplier.
- g. Retainage.
- h. Contract sum in sufficient detail.

**34.7** Provide for the Percentage of Contract Sum to nearest one-hundredth percent, adjusted to total 100 percent. Provide a breakdown of the Contract Sum in sufficient detail to facilitate continued evaluation of Applications for Payment and progress reports. Coordinate with the Project Manual table of contents. Break principal subcontract amounts down into several line items.

**34.8** Round amounts to nearest whole dollar; the total shall equal the Contract Sum.

**34.9** Unit-Cost Allowances: Show the line-item value of unit-cost allowances, as a product of the unit cost, multiplied by the measured quantity. Estimate quantities from the best indication in the Contract Documents.

**34.10** General Conditions: Show line items for indirect costs and margins on actual costs only when such items are listed individually in Applications for Payment. Each item in the Schedule of Values and Applications for Payment shall be complete. Include the total cost and proportionate share of general overhead and profit margin for each item.

- a. Temporary facilities and other major cost items that are not direct cost of actual work-in-place shall be shown as separate line items in the Schedule of Values.

### **Article 35**

#### **APPLICATION OF PAYMENTS: GENERAL**

**35.1** Applications for Payment - General: Each Application for Payment shall be consistent with previous applications and payments as certified by the Architect and Construction Administrator and paid for by the Agency.

**35.1.1** The initial "Application for Payment", the "Application for Payment", at time of "Substantial Completion", and the final "Application for Payment", involve additional requirements.

**35.1.2** Payment-Application Terms: The Agency will process monthly progress payments. The Contractor may submit applications for payment on a monthly basis.

**35.1.3** Payment-Application Forms: Use the "Application for Payment" form as required by the Agency. Present the required information on electronic media printout in the approved Agency Form, multiple pages should be used if required.

**35.1.4** For each item, provide a column including but not limited to the following items:

- a. Item Number.
- b. Description of Work and Related Specification Section or Division.
- c. Scheduled Value, break down by units of material and units of labor.
- d. Work completed from previous application.
- e. Work completed this period.
- f. Materials presently stored.
- g. Total completed and stored to date of application.
- h. Percentage of Completion.
- i. Balance to Finish.
- j. Retainage

**35.2** Application Preparation: Complete every entry on the form. Include final payment only and execution by a person authorized to sign legal documents on behalf of the Contractor. The Construction Administrator will return incomplete applications without action. Verify that entries match data on the "Schedule of Values" and include amounts of Change Orders.

**35.3** Approval of the Schedule of Values by the Agency is required prior to any payment by the Agency.

**35.4** The Schedule of Values shall include a breakdown of the Contractor's general condition costs.

**35.4.1** Non-recurring costs, (i.e. mobilization costs, utility hook-ups, temporary heat) will be paid at the time of occurrence.

**35.4.2** Reoccurring costs will be paid in proportion to the percent of completion of the project.

**35.5** The Schedule of Values shall include a breakdown of Contract closeout costs including systems certification testing and acceptance, training, warranties, guarantees, as-builts and attic stock.

**35.6** The Contractor shall make periodic applications for payment, which shall be subdivided into categories corresponding with the approved Schedule of Values and shall be in such numbers of copies as may be designated by the Agency.

**35.7** Applications for Payment: Administrative actions and submittals, that must precede or coincide with submittal of the first Application for Payment and all subsequent Application for Payments including, but not limited to, the following items:

- a. List of subcontractors and suppliers' name, FEIN/Social Security numbers, and Connecticut Tax Registration Numbers.
- b. List of principal suppliers and fabricators.
- c. Schedule of Values.
- d. Contractor's Construction Schedule.
- e. Schedule of principal products.
- f. Submittal Schedule.
- g. List of Contractor's staff assignments.
- h. List of Contractor's principal consultants.
- i. Copies of all applicable permits.
- j. Copies of authorizations and licenses from governing authorities for performance of the Work.
- k. Initial as-built survey and damage report, if required.
- l. Certified Payrolls.

### **Article 36**

## PARTIAL PAYMENTS

**36.1** The Agency and their representatives will examine the Contractor's applications for payments to determine, in the opinion of the Agency, the amounts that properly represent the value of the Work completed and for the materials suitably stored on the site.

**36.2** In making such Application For Payment for the Work, there shall be deducted **(7.5%) seven and a half percent** of the amount of each payment to be retained by the Agency until Final Completion.

**36.3** At the sole discretion of the Agency, and after completion and acceptance of (50%) fifty percent of the value of the Work, and if the character and progress of the Work remain satisfactory, the retained portion of the Application for Payments may be reduced to five percent (5%) of total payments. The minimum total amount of payment retained, prior to the Final Payment shall not be less than five percent (5%) of the Contract Sum.

**36.4** The decision of the Agency to reduce the retainage rate will be based upon the Contractor's performance for completed portions of the Work as set out below and other factors the Agency may find appropriate:

**36.4.1** The Contractor's timely submission of an appropriate and complete CPM Schedule or Construction Schedule and Schedule of Values, in compliance with the Contract requirements and the prompt resolution of the Agency's and/or Architect's comments on the submitted material resulting in an appropriate basis for progress of the Work.

**36.4.2** The Contractor's timely and proper submission of all Contract required submissions: including but not limited to shop drawings, material certificates and material samples and the prompt resolution of the Agency's and/or Architect's comments on the submitted material resulting in an appropriate progress of the Work.

**36.4.3** The Contractor's provision of proper and adequate supervision and home office support of the Project and any Subcontractor Work resulting in coordinated progress and proper quality control for the Work.

**36.4.4** The Work completed to date has been installed or finished in an acceptable manner which is satisfactory to the agency.

**36.4.5** The progress of the Work is consistent with the approved CPM Schedule or Construction Schedule.

**36.5** No payments will be made for improperly stored or protected materials or unacceptable Work.

## Article 37

### APPLICATION FOR PAYMENT at SUBSTANTIAL COMPLETION

**37.1** Application for Payment at Substantial Completion: Following issuance of the Certificate of Substantial Completion submit an Application for Payment form, use the form as required by the Agency. Present the required information on electronic media printout.

**37.1.1** This application shall reflect Certificates of Partial Substantial Completion issued previously for Agency occupancy of designated portions of the Work.

**37.2** Administrative actions and submittals that shall precede or coincide with this application include, but are not limited to, the following:

- a. Occupancy permits and similar approvals.
- b. Warranties (guarantees) and maintenance agreements.
- c. Test/adjust/balance records.
- d. Maintenance instructions.
- e. Meter readings.
- f. Startup performance reports.
- g. Changeover information related to Owner's occupancy, use, operation, and maintenance.
- h. Final cleaning.
- i. Consent of surety.
- j. Advice on shifting insurance coverage.
- k. Final progress photographs.
- l. List of incomplete Work, recognized as exceptions to Architect's Certificate of Substantial Completion.
- m. Change of door locks to Owner's access.

**Article 38**  
**FINAL APPLICATION FOR PAYMENT**

**38.1** Final Payment Application: Administrative actions and submittals that must precede or coincide with submittal of the final Application for Payment include, but are not limited, to the following:

- a. Completion of Project Closeout requirements.
- b. Completion of list of items remaining to be completed as indicated on the attachment to the Certificate of Substantial Completion.
- c. Ensure that unsettled claims will be settled.
- d. Ensure that incomplete Work is not accepted and will be completed without undue delay.
- e. Transmittal of required Project construction records to the Owner.
- f. Certified property survey.
- g. Proof that taxes, fees, and similar obligations were paid.
- h. Removal of temporary facilities and services.
- i. Removal of surplus materials, rubbish, and similar elements.
- j. The requirements of the General Conditions and Supplementary Conditions for Final Acceptance, Final Completion, Final Inspection, and Final Payment.
- k. Asbestos, Lead or other hazardous material manifests.
- l. Completion of "Building Contractor Reporting Form" for all Contractors, Subcontractors, Vendors, Suppliers, etc. who work on the Contract. The form includes the following information:
  - Contractor/Subcontractor name,
  - FEIN/Social Security Numbers, Connecticut Tax Registration Numbers, Type of work, Name of business and address, Remittance address.
- m.

**Article 39**  
**DELIVERY OF STATEMENT SHOWING**  
**AMOUNTS DUE FOR WAGES, MATERIALS AND**  
**SUPPLIES**

**39.1** For each Application for Payment under this Contract, the Agency reserves the right to require the Contractor and every Subcontractor to submit a written verified statement, in a form satisfactory to the Agency, showing in detail all amounts then due and unpaid by such Contractor or Subcontractor for daily or weekly wages to all laborers em-

ployed by him for the performance of the Work or to other persons for materials, equipment or supplies delivered at the site.

**39.2** The term laborers as used herein shall include workmen, workwomen, and mechanics.

**39.3** Failure to comply with this requirement may result in the Agency withholding the application for payment pursuant to Article 28.

**Article 40**  
**CONTRACT CLOSEOUT**

**40.1** Substantial Completion: Before requesting inspection for Certification of Substantial Completion, complete the following. List exceptions in the request.

- a. In the Application for Payment that coincides with, or first follows, the date Substantial Completion is claimed, show 100 percent completion for the portion of the Work claimed as substantially complete.
  - i. Include supporting documentation for completion as indicated in these Contract Documents and a statement showing an accounting of changes to the Contract Sum.
  - ii. If 100 percent completion cannot be shown, include a list of incomplete items, the value of incomplete construction, and reasons the Work is not complete.
- b. Advise the Agency of pending insurance changeover requirements.
- c. Submit specific warranties, workmanship bonds, maintenance agreements, final certifications, and similar documents.
- d. Obtain and submit releases enabling the Agency unrestricted use of the Work and access to services and utilities. Include occupancy permits, operating certificates, and similar releases.
- e. Submit record drawings, maintenance manuals, damage or settlement surveys, property surveys, and similar final record information.
- f. Deliver tools, spare parts, extra stock, and similar items.
- g. Make final changeover of permanent locks and transmit keys to the Agency.

- Advise the Agency's personnel of changeover in security provisions.
- h. Demonstration, through operation and testing, the functions of all systems and/or equipment to the satisfaction of the Agency for compliance to the contract. Complete testing of systems, and instruction of the Agency's operation and maintenance personnel. Discontinue and remove temporary facilities from the site, along with mockups, construction tools, and similar elements.
  - i. Complete final cleanup requirements, including touchup painting.
  - j. Touch up and otherwise repair and restore marred, exposed finishes.

**40.1.1** Inspection Procedures: The Contractor shall be ready and prepared when they request a Substantial Completion inspection. If the inspection reveals that the work is not complete, there are extensive punchlist items and as the items listed above are not complete, the Construction Administrator, Architect, and Agency will determine the inspection has failed.

**40.1.2** The Contractor is responsible for all costs to re-inspect due to a failed inspection. The Agency will issue a deduct change order to cover all costs for re-inspection.

- a. The Architect will repeat inspection when requested and assured that the Work is substantially complete.
- b. Results of the completed inspection will form the basis of requirements for final acceptance.

**40.2** Final Acceptance: Before requesting final inspection for certification of final acceptance and final payment, complete the following. List exceptions in the request.

- a. Submit the final payment request with releases and supporting documentation not previously submitted and accepted. Include insurance certificates for products and completed operations where required.
- b. Submit an updated final statement, accounting for final additional changes to the Contract Sum.
- c. Submit a certified copy of the Architect's final inspection list of items to be completed or corrected, endorsed and dated by the Architect. The certified copy of the list shall state that each item has been completed or otherwise resolved for acceptance and shall be endorsed and dated by the Architect.
- d. Submit final meter readings for utilities, a measured record of stored fuel, and similar data as of the date of Substantial Completion or when the Agency took possession of and assumed responsibility for corresponding elements of the Work.
- e. Submit consent of surety to Final Payment.
- f. Submit evidence of final, continuing insurance coverage complying with insurance requirements.

**40.2.1** Reinspection Procedure: The Inspection Group will re-inspect the Work upon receipt of notice from the Construction Administrator that the Work, including inspection list items from earlier inspections, has been completed, except for items whose completion is delayed under circumstances acceptable to the Agency.

**40.2.2** Upon completion of reinspection, the Construction Administrator will prepare a certificate of final acceptance. If the Work is incomplete, the Construction Administrator will advise the Contractor of Work that is incomplete or of obligations that have not been fulfilled but are required for final acceptance.

**40.3 Record Document Submittals:** Do not use record documents for construction purposes. Protect Record Documents from deterioration and loss in a secure, fire-resistant location. Provide access to record documents for the Architect's reference during normal working hours. Keep documents current; do not permanently conceal any work until required information has been recorded. Failure to keep documents current is sufficient cause to withhold progress payments.

**40.3.1** The Contractor shall also hire the services of a Surveyor registered in the State of Connecticut to conduct a final survey to determine the location of exterior underground utility lines and to record the results, and update existing electronic media.

**40.3.2** The record of exterior underground utilities shall be made at the time of installation on Mylar film drawing and AutoCAD (latest version) compatible disks. The drawing shall bear the seal of the Land Surveyor and a statement of accuracy.

**40.4 Record Drawings:** The Contractor shall maintain one clean, complete undamaged set of blue or black line white-prints of Contract Drawings and Shop Drawings. Mark the set to show the actual installation where the installation varies substantially from the Work as originally shown. Mark which drawing is most capable of showing conditions fully and accurately. Where Shop Drawings are used, record a cross-reference at the corresponding location on the Contract Drawings. Give particular attention to concealed elements that would be difficult to measure and record at a later date. The Contractor shall provide the following:

- a. Mark record sets with erasable pencil to distinguish between variations in separate categories of the Work.
- b. Mark all new information that is not shown on Contract Drawings.
- c. Note related change-order numbers where applicable.
- d. Organize record drawing sheets into manageable sets. Bind sets with durable-paper cover sheets; print suitable titles, dates, and other identification on the cover of each set.
- e. Upon completion of the work, the Contractor shall submit Record Drawings to the Construction Administrator for the Agency's Records who will pass them on to the Architect or Engineer for transferring the changes to the Record Drawing Mylar Tracings.
- f. Submit electronic format data of all revised drawings on CD-ROM format and in AutoCAD (latest version) compatible format.

**40.5 Record Specifications:** The Contractor shall maintain one complete copy of the Project Manual, including Addenda. Include with the Project Manual one copy of other written construction documents, such as Change Orders and modifications issued in printed form during construction. The Contractor shall provide the following:

- a. Mark these documents to show substantial variations in actual Work performed in comparison with the text of the Specifications and modifications.
- b. Give particular attention to equals and substitutions and selection of options and information on concealed construction that cannot otherwise be readily discerned later by direct observation.
- c. Note related record drawing information and Product Data.
- d. Upon completion of the Work, submit record Specifications to the Construction Administrator for the Agency's records.

**40.6 Record Product Data:** The Contractor shall maintain one copy of each Product Data submittal. Note related Change Orders and markup of record drawings and Specifications. The Contractor shall provide the following:

- a. Mark these documents to show significant variations in actual Work performed in comparison with information submitted. Include variations in products delivered to the site and from the manufacturer's installation instructions and recommendations.
- b. Give particular attention to concealed products and portions of the Work that cannot otherwise be readily discerned later by direct observation.
- c. Upon completion of markup, submit complete set of Record Product Data to the Construction Administrator for the Agency's records.

**40.7 Record Sample Submitted:** Immediately prior to Substantial Completion, the Contractor shall meet with the Construction Administrator, Architect and the Agency's personnel at the Project Site to determine which Samples are to be transmitted to the Agency for record purposes. Comply with the Agency's instructions regarding delivery to the Agency's Sample storage area.

**40.8 Miscellaneous Record Submittals:** Refer to other Specification Sections for requirements of miscellaneous record keeping and submittals in connection with actual performance of the Work. Immediately prior to the date or dates of Substantial Completion, complete miscellaneous records and place in good order. Identify miscellaneous

records properly and bind or file, ready for continued use and reference. Submit to the Construction Administrator for the Agency's records.

**40.9 Maintenance Manuals:** Organize operation and maintenance data into suitable sets of manageable size. Bind properly indexed data in individual, heavy-duty, 2-inch (51-mm), 3-ring, vinyl-covered binders, with pocket folders for folded sheet information. Mark appropriate identification on front and spine of each binder according to section 01730. Included but not limited to the following types of information:

- a. Emergency instructions.
- b. Spare parts list.
- c. Copies of warranties.
- d. Wiring diagrams.
- e. Recommended "turn-around" cycles.
- f. Inspection procedures.
- g. Shop Drawings and Product Data.
- h. Fixture lamping schedule.
- i. MSDS Sheets for all material used and or placed within the Project.

**40.10 Closeout Procedures:** Arrange for each Installer of equipment that requires regular maintenance to meet with the Agency's personnel to provide instruction in proper operation and maintenance. Provide instruction by manufacturer's representatives if installers are not experienced in operation and maintenance procedures. Include a detailed review of the following items:

- a. Maintenance manuals.
- b. Record documents.
- c. Spare parts and materials.
- d. Tools.
- e. Lubricants.
- f. Fuels.
- g. Identification systems.
- h. Control sequences.
- i. Hazards and hazardous materials.
- j. Cleaning.
- k. Warranties and bonds.
- l. Maintenance agreements and similar continuing commitments.
- m. Copy of all submittals.

**40.10.1** As part of instruction for operating equipment, the Contractor shall demonstrate the following procedures:

- a. Startup.
- b. Shutdown.
- c. Emergency operations.
- d. Noise and vibration adjustments.
- e. Safety procedures.
- f. Economy and efficiency adjustments.
- g. Effective energy utilization.

**40.11 Final Cleaning:** The General Conditions requires general cleaning during construction. Regular site cleaning is included in Division 1 Section 01570 "Cleaning".

**40.11.1** The Contractor shall employ experienced workers or professional cleaners for final cleaning. Clean each surface or unit to the condition expected in a normal, commercial building cleaning and maintenance program. Comply with manufacturer's instructions. Complete the following cleaning operations before requesting inspection for Certification of Substantial Completion and Certification of Occupancy.

Interior:

- a. Remove labels that are not permanent labels.
- b. Clean transparent materials, including mirrors and glass in doors and windows. Remove glazing compounds and other substances that are noticeable vision-obscuring materials. Replace chipped or broken glass and other damaged transparent materials. Remove paint spots; wash and polish glass.
- c. Clean exposed interior hard-surfaced finishes to a dust-free condition, free of stains, films, and similar foreign substances. Restore reflective surfaces to their original condition. Leave concrete floors broom clean. Vacuum carpeted surfaces.
- d. Wash washable surfaces of mechanical, electrical equipment and fixtures and replace filters, clean strainers on mechanical equipment. Remove excess lubrication and other substances. Clean plumbing fixtures to a sanitary condition. Clean light fixtures and lamps.

- Exterior:
- e. Clean and polish finish hardware.
  - f. Clean and polish tile and other glazed surfaces.
  - g. Clean floors; wax and buff resilient tile. Clean vinyl or rubber base.
  - h. Vacuum and/or dust walls, ceilings, lighting fixtures, ceiling diffusers and other wall and ceiling items.
  - i. Remove defacements, streaks, fingerprints and erection marks.
- a. Clean the site, including landscape development areas, of rubbish, litter, and other foreign substances. Sweep paved areas broom clean; remove stains, spills, and other foreign deposits. Rake grounds that are neither paved nor planted, to a smooth, even-textured surface.
  - b. Clean exposed exterior hard-surfaced finishes to a dust-free condition, free of stains, films, and similar foreign substances.
  - c. Clean roofs, gutters and downspouts.
  - d. Remove waste and surplus materials, rubbish and construction equipment and facilities from the site, and deposit it legally elsewhere.
  - e. Clean transparent materials, including mirrors and glass in doors and windows. Remove glazing compounds and other substances that are noticeable vision-obscuring materials. Replace chipped or broken glass and other damaged transparent materials. Remove paint spots; wash and polish glass.

**40.12 Pest Control:** Engage an experienced, licensed exterminator to make a final inspection and rid the work of rodents, insects, and other pests.

**40.13 Removal of Protection:** Remove temporary protection and facilities installed for protection of the Work during construction.

**40.14 Compliance:** Comply with regulations of authorities having jurisdiction and safety standards for cleaning. Do not burn waste materials. Do not bury debris or excess

materials on the Agency's property. Do not discharge volatile, harmful, or dangerous materials into drainage systems. Remove waste materials from the site and dispose of lawfully.

**40.15** Where extra materials of value remain after completion of associated Work, they become the Agency's property. Dispose of these materials as directed by the Construction Administrator.

**40.16** Leave building clean and ready for occupancy. If the Contractor fails to clean up, the Agency may do so, with the cost charged to the Contractor. The Agency will issue a credit change order to cover the costs.

#### **Article 41** **OPERATION AND MAINTENANCE DATA**

**41.1** The Contractor shall instruct the State's designated personnel in the operation of new equipment and shall provide manuals and provide video tapes of this basic maintenance of the equipment for training purposes. Provide qualified personnel for as long as necessary to instruct the Agency's personnel.

**41.2** Submit four copies of the manuals in 3-ring, loose-leaf notebooks to the Architect/Engineer for approval. Manuals may consist of plain paper copies of approved shop drawings and catalog cuts. Upon completion and approval, 3 copies will be forwarded to the Agency and one copy retained by the Architect/Engineer.

**41.2.1** Manuals shall include:

- 41.2.1.1.** Operating Procedures:
  - a. Typewritten procedures for each mode of operation of each piece of equipment. Procedures shall indicate the status of each component of a system in each operating mode.
  - b. Procedures shall include names, symbols, valve tags, circuit numbers, schematic wiring diagrams, locations of thermostats, manual starters, control cabinets and other controls of each system.
  - c. Emergency shut-down procedures for each piece of equipment or system, both automatic and manual, as appropriate.
- 41.2.1.2** Maintenance Schedule:
  - a. Typewritten schedule describing manufacturers schedule of maintenance and maintenance procedures.
- 41.2.1.3** Catalog Cuts:
  - a. To illustrate each piece of installed equipment, including options.
  - b. Include equipment descriptions including physical, electrical and mechanical; performance characteristics; installation or erection diagrams.
  - c. Include spare parts numbers and names, address and phone number of manufacturer; name, address and phone number of local representative or service department.

**41.3** Typewritten list of all subcontractors on the project, including name, address and phone number of local representative or service department.

**41.4** Manuals shall be indexed with dividers indicating each system or piece of equipment.

**Article 42**  
**COMPLETION AND ACCEPTANCE**

**42.1 Substantial Completion:**

**42.1.1** When the Contractor considers that the Work, or a portion thereof is Substantially Complete, the Contractor shall request an inspection of said Work to the Construction Administrator.

**42.1.2** Upon receipt of the request, the Architect,

Construction Administrator and Agency, will make an inspection to determine if the Work or designated portion thereof is Substantially Complete. If the inspection discloses any item, whether or not included on the inspection list, which is not in accordance with the requirements of the Contract Documents, the Contractor shall, before issuance of the Certificate of Substantial Completion, complete or correct such item.

**42.1.3** The Contractor shall then submit a request for another inspection. The determination of Substantial Completion is solely within the discretion of the Agency.

**42.1.4** When the Work or designated portion thereof is determined to be Substantially Complete, the Contractor will be provided a Certificate of Substantial Completion from the Agency. The Certificate of Substantial Completion, shall establish the date when the responsibilities of the Contractor for security, maintenance, heat, utilities, damage to the Work and insurance, are transferred to the Agency and shall fix the time within which the Contractor shall finish all items on the inspection list accompanying the Certificate.

**42.1.5** The Certificate of Substantial Completion shall be signed by the Contractor, Construction Administrator, Agency, and Architect.

**42.1.6** Upon Substantial Completion of the Work or designated portion thereof and upon application by the Contractor and certification by the Construction Administrator and Architect, the Agency shall make payment reflecting adjustment in retainage, if any, for such Work or portion thereof as provided in the Contract Documents.

**42.2 Final Completion:**

**42.2.1** Upon Final Completion of the Work, the Contractor shall forward to the Construction Administrator a written notice that the Work is ready for Final Inspection and Acceptance and shall also forward to the Construction Administrator, a Final Application for Payment. Upon determination by the Agency that all the Work is complete, the Agency will issue a Certificate of Completion and Acceptance.

**42.2.2** When the Work has been completed in accordance with terms and conditions of the Contract Documents a Certificate of Completion shall be issued to be signed by the Contractor, Construction Administrator, Architect and Agency.

**Article 43**  
**FINAL PAYMENT**

**43.1** The Agency reserves the right to retain for a period of thirty (30) days after filing and acceptance of the Certificate

of Completion and Acceptance the amount therein stated less all prior payments and advances whatsoever to or for the account of the Contractor.

**43.2** All prior estimates and payments, including those relating to extra or additional Work, shall be subject to correction by the Final Payment.

**43.3** No Application for Payment, Final or Partial, shall act as a release to the Contractor or the Contractor's sureties from any obligations under this Contract.

**43.4** The Architect and Construction Administrator will promptly issue the Certificate for Payment, stating that to the best of their knowledge, information and belief, and on the basis of their observations and inspections, the Work has been completed in accordance with terms and conditions of the Contract Documents and that the entire balance found to be due the Contractor and noted in said Final Payment is due and payable.

**43.5** Final Payment shall not be released until a Certificate of Completion and Acceptance and a Certificate of Compliance have been issued.

**43.6** Neither Final Payment nor any remaining retained percentage shall become due until the Contractor submits to the Agency the following:

**43.6.1** An affidavit that payrolls, bills for materials and equipment, and other indebtedness connected with the Work for which the Agency or the Agency's property might be responsible or encumbered (less amounts withheld by Agency) have been paid or otherwise satisfied.

**43.6.2** A certificate evidencing that insurance required by the Contract Documents to remain in force after Final Payment is currently in effect and will not be canceled or allowed to expire without at least 30 days prior written notice to the Agency.

**43.6.3** A written statement that the Contractor knows of no substantial reason that the insurance will not be renewable to cover the period required by the Contract Documents.

**43.6.4** Written consent of surety, if any, to Final Payment.

**43.6.5** If required by the Agency, other data establishing payment or satisfaction of obligations, such as receipts, releases and waivers of liens, claims, security interests or encumbrances arising out of the Contract, to the extent and in such form as may be designated by the Agency. If a Subcontractor refuses to furnish a release or waiver required by the Agency, the Contractor may furnish a bond satisfactory to the Agency to indemnify the Agency against such lien. If such lien remains unsatisfied after payments are made, the Contractor shall

refund to the Agency all money that the Agency may be compelled to pay in discharging such lien, including all costs and reasonable attorney's fees.

**43.6.6** If, after Substantial Completion of the Work, Final Completion thereof is materially delayed through no fault of the Contractor or by issuance of Change Orders affecting Final Completion and the Construction Administrator and Architect so confirm, the Agency shall, upon application by the Contractor and certification by the Construction Administrator and Architect, and without terminating the Contract, make payment of the balance due for that portion of the Work fully completed and accepted. If the remaining balance for Work not fully completed or corrected is less than retainage stipulated in the Contract Documents, and if bonds have been furnished, the written consent of surety to payment of the balance due for that portion of the Work fully completed and accepted shall be submitted by the Contractor to the Agency prior to Final Payment. Such payment shall be made under terms and conditions governing Final Payment, except that it shall not constitute a waiver of Claims.

#### **Article 44** **AGENCY'S RIGHT TO WITHHOLD PAYMENTS**

**44.1** The Agency may withhold a portion of any Payment due the Contractor that may, in the judgment of the Agency, be necessary:

**44.1.1** To assure the payment of just claims then due and unpaid to any persons supplying labor or materials for the Work.

**44.1.2** To protect Agency from loss due to defective, unacceptable or non-conforming Work not remedied by the Contractor.

**44.1.3** To protect the Agency from loss due to injury to persons or damage to the Work or property of other Contractors, Subcontractors, or others caused by the act or neglect of the Contractor or any of its Subcontractors.

**44.2** The Agency shall have the right to apply any amount withheld under this section as the Agency may deem proper to satisfy protection from claims. The amount withheld shall be considered a payment to the Contractor.

**44.3** The Agency has the right to withhold payment if the Contractor fails to provide accurate submissions of submittals, up date the status including but not limited to the following: as-built documents, request for information (RFI) log, Schedule, submittal log, change order log, certified payrolls and daily reports and all other requirement of the Contract Documents.

**44.4** Neither Final Payment nor any remaining retained percentage shall become due until the Contractor submits to the Architect through the Construction Administrator:

**44.4.1** An affidavit that payrolls, bills for materials and equipment, and other indebtedness connected with the Work for which the Agency or the Agency's property might be responsible or encumbered (less amounts withheld by Agency) have been paid or otherwise satisfied,

**44.4.2** A certificate evidencing that insurance required by the Contract Documents to remain in force after Final Payment is currently in effect and will not be canceled or allowed to expire until at least 30 days' prior written notice has been given to the Agency,

**44.4.3** A written statement that the Contractor knows of no substantial reason that the insurance will not be renewable to cover the period required by the Contract Documents,

**44.4.4** Consent of surety, if any, to Final Payment and

**44.4.5** If required by the Agency, other data establishing payment or satisfaction of obligations, such as receipts, releases and waivers of liens, claims, security interests or encumbrances arising out of the Contract, to the extent and in such form as may be designated by the Agency.

**44.5** If a Subcontractor refuses to furnish a release or waiver required by the Agency, the Contractor may furnish a bond satisfactory to the Owner to indemnify the Agency against such lien. If such lien remains unsatisfied after payments are made, the Contractor shall refund to the Agency all money that the Agency may be compelled to pay in discharging such lien, including all costs and reasonable attorney's fees.

#### **Article 45** **AGENCY'S RIGHT TO STOP WORK OR** **TERMINATE CONTRACT**

**45.1** The Agency shall have the authority to suspend the Work wholly or in part, for such period or periods as the Agency considers to be in the best interests of the State, or in the interests of public necessity, convenience or safety. During such periods the Contractor shall store all materials and equipment, in such a manner to prevent the materials and equipment from being damaged in any way, and the Contractor shall take precautions to protect the Work from damage.

**45.1.1** If the Agency, in writing, orders the performance of all or any portion of the Work to be suspended or delayed for an unreasonable period of time (i.e. not originally anticipated, customary, or inherent in the construction industry) and the

Contractor believes that additional compensation and/or Contract Time is due as a result of such suspension or delay, the Contractor shall submit to the Agency in writing a request for a Contract adjustment within 7 calendar days of receipt of the notice to resume Work. The request shall set forth the specific reasons and support for said adjustment.

**45.1.2** The Agency shall evaluate any such requests received. If the Agency agrees that the cost and/or time required for the performance of the Contract has increased as a result of such suspension and that the suspension was caused by conditions beyond the control of and not the fault of the Contractor, its suppliers, or Subcontractors, and was not caused by weather, then the Agency will make a reasonable adjustment, excluding profit, of the Contract terms. The Agency will notify the Contractor of the determination as to what adjustments of the Contract, if any, that the Agency deems warranted.

**45.1.3** No Contract adjustment will be made unless the Contractor has submitted the request for adjustment within the time prescribed.

**45.1.4** No contract adjustment will be made under this Article to the extent that performance would have been suspended or delayed by any other cause within the Contractor's control or by any factor for which the Contractor is responsible under the Contract; or that such an adjustment is provided for or excluded under other term or condition of this Contract.

**45.2** Notwithstanding any provision or language in the Contract to the contrary, the State may terminate the Contract whenever the Agency determines at their sole discretion that such termination is in the best interests of the State. Any such termination shall be effected by delivery to the Contractor of a written Notice of Termination specifying the extent to which performance of Work under the Contract is terminated, and the date upon which such termination shall be effective.

**45.2.1** In the event of such termination, the Contractor shall be entitled to reasonable compensation as determined by the Agency, however, no claim for lost overhead or profits shall be allowed.

**45.2.2** Materials obtained by the Contractor for the Work that have been inspected, tested as required, and accepted by the Agency, and that are not incorporated into the Work, shall, at the option of the Agency, be purchased from the Contractor at actual cost as shown by receipted bills. To this cost shall be added all actual costs for delivery at such points of delivery as may be designated by the Agency, as shown by actual cost records.

**45.2.3** Termination of the Contract shall not relieve the Contractor or its Surety of their responsibilities for the completed Work, nor shall it relieve the Contractor's Surety of its obligations to ensure completion of the Work and to pay legitimate claims arising out of Work.

**Article 46**  
**SUBLETTING OR ASSIGNING OF CONTRACT**

**46.1** The Contract or any portion thereof, or the Work provided for therein, or the right, title or interest of the Contractor therein may not be sublet, sold, transferred, assigned, or otherwise disposed of to any person, firm or corporation without the written consent of the Agency.

**46.2** No person, firm or corporation other than the Contractor to whom the Contract was awarded shall be permitted to commence Work at the site of the Contract until such consent has been granted.

**Article 47**  
**CONTRACTOR'S INSURANCE**

**47.1** The Contractor shall not start Work under the Contract until they have obtained insurance as stated in SECTIONS 00300 CERTIFICATE OF INSURANCE and 00020 BID PROPOSAL FORM, subsections 4.4.2 and 4.4.3, of the Contract Documents and until the insurance has been approved by the Agency. The Contractor shall not allow any Subcontractor to start Work until the same insurance has been obtained by the Subcontractor and approved by the Agency or the Contractor's insurance provides coverage on behalf of the Subcontractor. The Contractor shall send Certificates of Liability Insurance to the Agency unless otherwise directed in writing. Presented below is a narrative summary of the insurance required.

**47.1.1 Commercial General Liability** insurance including contractual liability, products/completed operations, broad form property damage and independent Contractors. The limits shall be no less than \$1,000,000 each occurrence and \$2,000,000 annual aggregate. Coverage for hazards of explosion, collapse and underground (X-C-U) must also be included when applicable to the Work to be performed. The State of Connecticut and Eastern Connecticut State University shall be named as an Additional Insured. This coverage shall be provided on a primary basis.

**47.1.2 Agency's and Contractor's Protective Liability** insurance providing a total limit of \$1,000,000 for all damages arising out of bodily injury or death of persons in any one accident or

occurrence and for all damages arising out of injury or destruction of property in any one accident or occurrence and subject to a total (aggregate) limit of \$2,000,000 for all damages arising out of bodily injury to or death of persons in all accidents or occurrences and out of injury to or destruction of property during the policy period. This coverage shall be for and in the name of the State of Connecticut and Eastern Connecticut State University.

**47.1.3** The operation of all motor vehicles including those owned, non-owned and hired or used in connection with the Contract shall be covered by **Automobile Liability** insurance providing for a total limit of \$1,000,000 for all damages arising out of bodily injuries to or death of all persons in any one accident or occurrence and for all damages arising out of injury to or destruction of property in any one accident or occurrence. In cases where an insurance policy shows an aggregate limit as part of the automobile liability coverage, the aggregate limit must be at least \$2,000,000. This coverage shall be provided on a primary basis. Should the Contractor not own any automobiles, the automobile & liability requirement shall be amended to allow the Contractor to maintain only hired and non-owned liability.

**47.1.4 Workers' Compensation and Employer's Liability** as required by Connecticut Law and **Employers' Liability** with a limit of not less than \$100,000 per occurrence, \$500,000 disease policy limit and \$100,000 disease each employee. When Work is on or contiguous to navigable bodies of waterways and ways adjoining, the Contractor shall include Federal Act endorsement for U.S. Longshoremen's and Harbor Workers Act.

**47.1.5 Special Hazards** insurance, if required, will be stated in SECTION 00020 BID PROPOSAL FORM, subsection 4.4.2 of this Project Manual. This includes coverage for explosion, collapse or underground damage and shall be no less than \$1,000,000 each occurrence.

**47.1.6 Builder's Risk** insurance, if required, will be stated in SECTION 00020 BID PROPOSAL FORM, subsection 4.4.3 of this Project Manual.

**47.1.7 Inland Marine/Transit Insurance:** With respect to property with values in excess of \$100,000 which is rigged, hauled or situated at the site pending installation, the Contractor shall maintain inland marine/transit insurance provided

the coverage is not afforded by a Builder's Risk policy.

**47.1.8 Satisfying Limits Under an Umbrella Policy:** If necessary, the Contractor may satisfy the minimum limits required above for either Commercial General Liability, Automobile Liability, and Employer's Liability coverage under an Umbrella or Excess Liability policy. The underlying limits may be set at the minimum amounts required by the Umbrella or Excess Liability policy provided the combined limits meet at least the minimum limit for each required policy. The Umbrella or Excess Liability policy shall have an Annual Aggregate at a limit not less than two (2) times the highest per occurrence minimum limit required above for any of the required coverages. The State of Connecticut and Eastern Connecticut State University shall be specifically endorsed as an Additional Insured on the Umbrella or Excess Liability policy, unless the Umbrella or Excess Liability policy provides continuous coverage to the underlying policies on a complete "Follow-Form" basis.

**47.2** Each insurance policy required to be maintained by the Contractor except Workers' Compensation and Automobile Liability shall endorse the State of Connecticut and Eastern Connecticut State University as an Additional Insured. Additional Insured endorsements shall provide coverage on a primary basis.

**47.3** When required to be maintained, the Builder's Risk and Inland Marine/Transit Insurance policy shall endorse the State of Connecticut and Eastern Connecticut State University as a Loss Payee.

**47.4** The Contractor shall, at its sole expense, maintain in full force and effect at all times during the life of the Contract or the performance of Work hereunder, insurance coverage as described herein. Certificates shall include a minimum thirty (30) day endeavor to notify requirement to the Agency prior to any cancellation or non-renewal.

**47.5** The Contractor shall be fully and solely responsible for any costs or expenses as a result of a coverage deductible, coinsurance penalty, or self-insured retention, including any loss not covered because of the operation of such deductible, coinsurance penalty, or self-insured retention.

**47.6** The requirement contained herein as to types and limits of insurance coverage to be maintained by the Contractor are not intended to and shall not in any manner limit or qualify the liabilities and obligations assumed by the Contractor.

**47.7 Hold Harmless Provisions:** The Contractor shall at all times indemnify and save harmless the State of Connecticut, Eastern Connecticut State University, and their respective officers, agents, and employees, on account of any and all claims, damages, losses, litigation, expenses, counsel fees and compensation arising out of injuries (including death) sustained by or alleged to have been sustained by the officers, agents, and employees of said State or Department, or of the Contractor, his Subcontractor, or materialmen and from injuries (including death) sustained by or alleged to have been sustained by the public, any or all persons on or near the Work, or by any other person or property, real or personal (including property of said State or Department) caused in whole or in part by the acts, omissions, or neglect or the Contractor including but not limited to any neglect in safeguarding the Work or through the use of unacceptable materials in constructing the Work of the Contractor, any Subcontractor, materialmen, or anyone directly employed by them or any of them while engaged in the performance of the Contract, including the entire elapsed time from the date of the Notice to Proceed or the actual commencement of the Work whichever occurs first until its completion as certified by the Agency.

**Article 48**  
**FOREIGN MATERIALS**

**48.1** Preference shall be given to articles or materials manufactured or produced in the United States, conditions of quality and price with duty being equal.

**48.2** Only domestic articles or materials will be used unless a statement is submitted with the proposal that enumerates the foreign articles of materials proposed to be used and such proposal is accepted by the Agency. The foregoing provisions shall not apply to foreign articles or materials required by the Contract Documents.

**Article 49**  
**MATERIALS AND EQUIPMENT CONTROLS**

**49.1 Materials and Equipment:** Shall be delivered to the project site, stored and handled to prevent intrusion of foreign matter and damage by weather or breakage. Packaged materials shall be delivered and stored in original, unbroken packages. **DO NOT DELIVER MATERIALS TO THE AGENCY'S SHIPPING & RECEIVING LOADING DOCKS.**

**49.1.1** Promptly inspect shipments to assure that products comply with requirements, that quantities are correct and products are undamaged.

**49.1.2** Packages, materials and equipment showing evidence of damage will be rejected and replaced at no additional cost to the Agency.

**49.2 Storage and Protection:** The Contractor shall provide the following:

- a. Store products in accordance with manufacturers' instructions with seals and labels intact and legible. Store sensitive products in weathertight enclosures; maintain within temperature and humidity range required by manufacturer.
- b. For exterior storage of fabricated products, place on sloped supports above ground. Cover products subject to deterioration with impervious sheet covering; provide ventilation to avoid condensation.
- c. Store loose granular material on solid surfaces in a well-drained area; prevent mixing with foreign matter.
- d. Arrange storage to provide access for inspection. Periodically inspect to insure products are undamaged and are maintained under required conditions. Keep log showing date, time and problems, if any.
- e. Stone, masonry units and similar materials shall be stored on platforms or dry skids and shall be adequately covered and protected against damage.
- f. The Contractor shall prepare, as directed by the Agency, one area or space in the building for storage of State-owned equipment.

**Article 50**  
**IDENTIFICATION BADGES**

**50.1** Identification Badges for Contractor's Personnel, Visitors & Parking Stickers:

- a. The Contractor will provide each person working or visiting at the site with an identification badge, bearing the name of

the Contractor and a number. As badges are assigned, a record shall be kept by the Contractor and given to the Construction Administrator. Update and correct the records of all badges issued on a semi-monthly basis.

- b. Badges are to be worn on outer garment where visible at all times while at the construction site, return them to the Contractor's field office at the end of each day and pick them up there each morning.
- c. All vehicles parking in the Contractor's parking lot and those used around the site require an ID sticker. They will be issued by the Agency. Each contractor shall apply for parking stickers through the Construction Administrator no more than semi-monthly and shall keep record of all stickers issued.

**Article 51**  
**HOURS OF WORK**

**51.1** No person shall be employed to work or be permitted to work more than eight (8) hours in any day or more than forty (40) hours in any week for any Work provided in the Contract, in accordance with Connecticut General Statute Section 31-57.

**51.2** The operation of such limitation of hours of work may be suspended during an emergency, upon the approval of the Agency, in accordance with Connecticut General Statute Section 31-57.

**Article 52**  
**DAYS OF WORK**

**52.1** Working Calendar Days include all days that the Contractor is permitted to execute the Work or employ any person to execute the Work within the Contract Time.

**52.2** Non-working Calendar Days include all Saturdays, Sundays, Legal State Holidays and any other days identified in the Contract Documents that the Contractor is not permitted to execute the Work or employ any person to execute the Work. The restriction of non-working Calendar Days may be suspended upon the approval or direction of the Agency.

**Article 53**  
**CONTRACT TIME**

**53.1** The Contract Time is the number of calendar days, allotted in the Bidding Documents, for execution and Substantial Completion of the Work, including authorized ad-

justments thereto. The Contract Time is the sum of all working and non-working calendar days.

**53.2** If weather conditions prevent the Contractor from executing the Work, the Contract Time may be extended by Change Order, for such reasonable time as may be determined by the Agency.

**Article 54**  
**CALENDAR DAY**

**54.1** This is each day of the calendar.

**End of Section**

---

**01000 WORK COVERED BY CONTRACT DOCUMENTS**

---

- A. Project Number ECSU 2020-8 is entitled **Baseball, Softball, & Rugby, Field Renovation** project  
It is to be located in Mansfield, Connecticut. It is to be completed and ready for use by the Owner and Agency within the Contract Time specified in Section 00020 Bid Proposal Form.
- B. The Project Description:
1. The scope of work includes laser grading of infield mixes, irrigation system adjustments, and sod installation for the baseball and softball fields. Renovation of the existing rugby field including fraise mowing, vertical slit drainage, irrigation adjustments, and other surface and rootzone modifications.
  2. This Project **does not** exceed the Threshold Limits as defined by the Connecticut General Statutes.

---

**01001 OWNER AND AGENCY**

---

- A. Owner: The Owner is the Eastern Connecticut State University.
1. The authorized representative for the Owner is **Renee Theroux-Keech, Director of Facilities Management & Planning**. Facilities Management & Planning office is located at Eastern Connecticut State University, Facilities Building, 83 Windham Street, Willimantic, Connecticut 06226. Phone: 860-465-4596 Fax: 860-465-5318; E-mail: keechr@easternct.edu.

---

**01002 ARCHITECT AND ENGINEER:**

---

- A. The designer of record is **Facilities Management and Planning Department**, and is located at **ECSU**. The Engineer representing the agency for this project is **James W. Fielding**. Phone: 860-465-0239; Fax: 465-5318; E-mail: fieldingj@easternct.edu.
1. The Architect and Engineer or their accredited representative is referred to in the Contract Documents as "Architect" or "Architects" or "Engineer" or "Engineers" or by pronouns which imply them. As information for the Contractor, the Architect's or Engineer's status is defined as follows:
    - a. The Architect and Engineer will not make interpretations or decisions directly to the Contractor. All interpretations or decisions will be conveyed through the Construction Administrator.
    - b. As the authorized representative of the Owner, the Architect and Engineer is responsible for review of shop drawings, materials, and equipment intended for the work, in accordance with the "General Conditions", and the "Supplementary Conditions".
  3. Wherever the Architect or Engineer is mentioned in the documents in connection with an administrative function, it shall include the Construction Administrator in that function except for shop drawings.

---

**01003 CONSTRUCTION ADMINISTRATOR:**

---

- A. The Construction Administrator is James Fielding, and is located at **Eastern Connecticut State University, Facilities Building, 83 Windham Street., Willimantic Connecticut, 06226**,  
Phone: 869-465-0239; Fax: 860-465-5318; E-mail: fieldingj@easternct.edu.
1. The Construction Administrator is referred to in the Contract Documents as "Construction Administrator" or "Construction Manager" or by pronouns which imply it. All communications concerning the project will be directed through the Construction Administrator or a designated representative(s).
  2. As information to the Contractor, the Construction Administrator's status is defined as follows:
    - a. The Construction Administrator is the Owner's Agent who will, among other things, monitor the General Contractor's performance, scheduling and construction, process shop drawings, material, and equipment submittals, review and process periodic billings, review and recommend cost changes.
    - b. The Construction Administrator will process all requests for information, interpretations and decisions regarding the meaning and intent of the Contract Documents, consulting with appropriate parties prior to rendering the interpretations or decisions to the Contractor. All such requests and replies shall be in writing.

---

**01010 SUMMARY OF WORK**

---

- A.** Summary of Work includes but is not limited to the following:
  - 1. *Laser grading and supplemental addition of Duraedge mixes on infields for Baseball and Softball.*
  - 2. *Irrigation system adjustments for Baseball, Softball, and Rugby fields.*
  - 3. *Sod installation for the baseball infield area including the partial removal of sand-based rootzone mix.*
  - 4. *Renovation of the rugby field including fraise mowing, vertical slit drainage, core aeration, top dressing, and overseeding modifications.*
- B.** The Contractor will include in his bid, all items required in order to carry out the intent of the work as described, shown and implied in the Contract Documents.
- C.** It shall be the Contractor's responsibility upon discovery to immediately notify the Construction Administrator, in writing, of errors, omissions, discrepancies, and instances of noncompliance with applicable codes and regulations within the documents, and of any work which will not fit or properly function if installed as indicated on the Contract Documents. Any additional costs arising from the Contractor's failure to provide such notification shall be borne by the Contractor.
- D.** The Work will be constructed under a single lump.
- E.** Work Sequence - Phase(s):
  - 1. The entire Project shall be constructed in 1 Phase(s). Work of these Phase(s) shall be substantially complete, ready for occupancy within **90** Calendar Days of commencement of the Work.

---

**01011 EXAMINATION OF SITE**

---

- A.** It is not the intent of the Documents to show all existing conditions. All contractors are advised to visit and examine the site with the Construction Administrator prior to submitting bids.
- B.** Contractors should investigate and satisfy themselves as to the conditions affecting the work, including but not restricted to those bearing upon transportation, disposal, handling and storage of materials, availability of labor, water, electric power, uncertainties of weather, roads or similar physical conditions of the ground, the character of equipment, and facilities needed preliminary to and during the prosecution of the Work. The Contractor should further satisfy himself as to the character, quality, and quantity of surface and subsurface materials or obstacles to be encountered insofar as this information is reasonably ascertainable from an inspection of the site, as well as from information presented by the Contract Documents. Any failure by the Contractor to acquaint himself with the available information shall not relieve him from the responsibility for estimating properly the difficulty and cost of successfully performing the Work.
- C.** Pre-Bid Conference:
  - 1. A Mandatory Pre-Bid Conference and tour of the site will be conducted as scheduled in the Notice to Bidders. This scheduled conference is the only official opportunity for the bidders to tour the site with the Owner, Architect, Engineer, Construction Administrator, and Agency.

---

**01012 PROJECT DOCUMENTS**

---

- A.** The Specifications and Drawings are intended to describe and illustrate the materials and labor necessary for the work of this Project.
- B.** Throughout the Technical Specifications, the Connecticut Department of Transportation Standard Specifications for Roads, Bridges, and Incidental Construction Form 816, current addition including any interim and supplemental specifications are referenced. Where so referenced the requirements set forth therein are applicable and made a part hereof Copies of Form 814A are available from the Connecticut Department of Transportation at a nominal charge.

---

**01013 DOCUMENTS FURNISHED**

---

- A. The General Contractor will be given **3** sets of the Contract Documents on or about the time of execution of Contract, free of charge. If additional copies are wanted, they will be available at the direct additional cost of their reproduction, to the contractor.
- B. The Contractor shall receive one (1) set of AutoCAD compatible (latest version) Site Plans on disks at no cost on or about the time of execution of the Contract from the Architect. Additional sets of AutoCAD compatible (latest version) Site Plans on disks from the Architect at the cost of their reproduction, to the contractor.

---

**01014 CONTRACTOR'S USE OF PREMISES**

---

- A. The Contractor shall confine his operations, including storage of apparatus, equipment and materials to the contract limit lines as directed by the Construction Administrator.
- B. The areas and/or spaces, including their access, shall be maintained free and clear throughout the contract term.
- C. Parking for Contractor's employees will be limited to an area (or areas) designated by the Construction Administrator. The Contractor may be required to provide identification stickers for employees' cars.

---

**01015 OCCUPANCY REQUIREMENTS**

---

- A. **Full Agency Occupancy During Construction:** The Agency will occupy the existing building during the entire construction period. Cooperate with the Agency during construction operations to minimize conflicts and facilitate Owner usage. Perform the Work so as not to interfere with the Agency's operations.
- B. **Partial Agency Occupancy:** The Agency reserves the right to occupy and to place and install equipment in completed areas of the building prior to Substantial Completion, provided such occupancy does not interfere with completion of the Work. Such placing of equipment and partial occupancy shall not constitute acceptance of the total Work.
  - 1. Should it become necessary or advisable, as the work nears final completion, for the Agency to occupy a portion of the building prior to final acceptance, the Contractor shall cooperate in completing such areas and making same accessible.
  - 2. The Construction Administrator will determine whether such occupancy or use is possible and, if so, will make arrangements for holding a job inspection with the Project Manager, Agency Representative, Architect and General Contractor.
  - 3. A comprehensive list of items to be completed or corrected as issued by the General Contractor, together with the status of completion and terms of occupancy, will be forwarded to the Project Manager and the Architect by the Construction Administrator. A letter will be issued by the Project Manager and Architect to Construction Administrator granting such occupancy and will state the terms and conditions of occupancy.
  - 4. Prior to partial Agency occupancy, mechanical and electrical systems shall be fully operational. Required inspections and tests shall have been successfully completed. Upon occupancy, the Agency will operate and maintain mechanical and electrical systems serving occupied portions of the building.
  - 5. The Architect will prepare a "Certificate of Substantial Completion" for each specific portion of the Work to be occupied prior to Agency occupancy. Use the "Certificate of Substantial Completion" form as required by the Owner.
  - 6. The Project Manager will request a signed "Certificate of Compliance" from Commissioner of the Department of Public Works, Architect, and Contractor, if required.
  - 6. The Project Manager will request a signed "Certificate of Compliance" from the, Architect, and Contractor, and forward the Certificate to the Office of State Building Inspector for a Certificate of Occupancy and obtain the same after his review and approval.
  - 7. A letter from the Project Manager to the Agency Representative with copy to the General Contractor granting occupancy will state the terms and conditions of occupancy and that fire insurance coverage has been requested, the effective date of which will indicate to the Contractor that he may cancel fire insurance coverage for that portion of the project.

8. Upon occupancy, the Agency will assume responsibility for maintenance and custodial service for occupied portions of the building.
9. Work after Partial Agency Occupancy:
  - a. For all work to complete the area occupied, warranty work, the balancing and commissioning of systems, repair of latent defects and adjustments after partial occupancy, the contractor is responsible for all costs associated with working in occupied buildings.

**C. Agency Occupancy:**

1. The Construction Administrator will determine whether such occupancy is possible and, if so, will make arrangements for holding a job inspection with the Project Manager, Agency Representative, Architect and General Contractor.
2. A comprehensive list of items to be completed or corrected as issued by the General Contractor, together with the status of completion and terms of occupancy, will be forwarded to the Project Manager and the Architect by the Construction Administrator. A letter will be issued by the Project Manager and Architect to Construction Administrator granting such occupancy and will state the terms and conditions of occupancy.
4. Prior to Agency occupancy, mechanical and electrical systems shall be fully operational. Required inspections and tests shall have been successfully completed. Upon occupancy, the Agency will operate and maintain mechanical and electrical systems serving occupied portions of the building.
5. The Architect will prepare a "Certificate of Substantial Completion" for the Work to be occupied prior to Agency occupancy. Use the "Certificate of Substantial Completion" form as required by the Owner.
6. The Project Manager will request a signed "Certificate of Compliance" from Commissioner of the Department of Public Works, Architect, and Contractor, if required.
6. The Project Manager will request a signed "Certificate of Compliance" from the Architect, and Contractor, and forward the Certificate to the State Building Inspector a Certificate of Occupancy and obtain the same after his review and approval.
7. A letter from the Project Manager to the Agency Representative with copy to the General Contractor granting occupancy will state the terms and conditions of occupancy and that fire insurance coverage has been requested, the effective date of which will indicate to the Contractor that he may cancel fire insurance coverage for the project.
9. Upon occupancy, the Agency will assume responsibility for maintenance and custodial service for occupied portions of the building.
10. Work after Agency Occupancy:
  - a. For all work to complete the occupied building, warranty work, the balancing and commissioning of systems, repair of latent defects and adjustments after occupancy, the contractor is responsible for all costs associated with working in occupied buildings.

---

**01019 CONTRACT CONSIDERATIONS (NOT USED)**

---

**A. Allowances:**

1. The Contractor's costs for unloading and handling, labor, installation costs, storage, insurance, overhead and profit and other expense related to the Allowance item shall be included in the Lump Sum Bid Amount and not in the Allowance unless stated otherwise is the Allowance Schedule of this section.
2. Architect/Engineer:
  - a. Consult with Contractor for consideration of Products, suppliers and installers.
  - b. Select Products in consultation with the Project Manager and Agency Representatives and transmit decision to Construction Administrator.
  - c. Prepare Change Order.
3. Construction Administrator Responsibilities:

- a. Consult with Architect/Engineer, Contractor, Project Manager and Agency Representatives for consideration of Products, suppliers and installers.
- b. Select Products in consultation with Architect/Engineer, Project Manager and Agency Representatives and transmit decision to Contractor
- c. Prepare Change Order.
4. Contractor Responsibilities:
  - a. Assist Architect/Engineer and Construction Administrator in selection of Products and Suppliers.
  - b. Obtain proposals from Suppliers and offer recommendations.
  - c. On notification of selection by Construction Administrator execute purchase agreement with designated supplier.
  - d. Arrange for and process shop drawings, product data, and samples. Arrange for delivery.
  - e. If the actual cost of an Allowance item is more or less than the given amount, the Contract Sum will be adjusted by Change Order.
5. Allowance Schedule:
  - a. Section \_\_\_ - "\_\_\_": Include the Stipulated sum of \$ \_\_\_ for delivery of \_\_\_.
  - b. Section \_\_\_ - "\_\_\_": Include the Stipulated sum of \$ \_\_\_ for purchase of \_\_\_.
  - c. Section \_\_\_ - "\_\_\_": Include the Stipulated sum of \$ \_\_\_ for purchase and delivery of \_\_\_.
  - d. Section \_\_\_ - "\_\_\_": Include the Unit Price of \$ \_\_\_ for purchase and delivery of \_\_\_.

**B. Unit Prices - General:**

1. Definition - Unit Price: Amount the General Contractor acknowledges in the Bid Proposal Form as a price per unit of measurement for materials or services as described in the Bidding Documents or in the Contract Documents.
2. Procedures:
  - a. Unit Prices included in the Contract Documents are to be used for determining compensation to the Contractor or Owner for changes to the scope of the work indicated in the Contract Documents, and included in the Lump Sum Contract Price. Special Unit Prices are for items complete, in place, and shall be inclusive of furnishing and installing of all material, labor, trucking, overhead, profit, equipment, hoisting, engineering, scaffolding, power hookups, protection, shop drawings, taxes, permits, appliances, delivery, insurance, supervision, cost of bond, etc. and shall remain in effect until completion of the Contract.
  - b. Unit Price: Is identified by the Owner as a price per unit of measurement for materials or services added to or deducted from the Contract Sum by appropriate modification, if the estimated quantities of Work required by the Contract Documents are increased or decreased.
  - c. Increases or Decreases: Should the amount of the Work required be increased or decreased because of changes in the work ordered in writing by the Project Manager, the Undersigned agrees that the following supplemental UNIT PRICES will be decreased 10% for a reduction of work. Each Unit Price shall include all equipment, tools, labor, permits, fees, etc., incidental to the completion of the work involved. All items marked with an asterisk (\*) in the unit price schedules shall include the completion of the excavation, formation and compaction of sub-grade and the disposal of surplus or unsuitable materials in accordance with the Plans and Specifications or as directed by the Construction Administrator.
3. The Owner reserves the right to reject the Contractor's measurement of work-in-place that involves use of established unit prices, and to have this work measured, at the Owner's expense, by an independent surveyor acceptable to the Contractor.
4. Defect Assessment: Replace the Work, or portions of the Work, not conforming to the specified requirements, If, in the opinion of the Architect/Engineer it is not practical to remove and replace the work the Architect/Engineer will direct an appropriate remedy or adjust the payment.

5. Unit Price Schedule: A "Unit Price Schedule" is included at the end of this Section. Specification Sections referenced in the Schedule contain requirements for materials described under each unit price.

**C. Unit Price Schedule - Earth and Rock Excavation:** This Section includes administrative and procedural requirements for the following unit prices and provisions are to be included in and become part of this Contract to be used in evaluating additions to or deductions from the work called for in the specifications and/or plans.

1. Unless otherwise specified elsewhere in these documents, Contractors are to assume that all excavation is earth; however, if unspecified rock is encountered, it will be paid for at the given unit prices listed in paragraph "F". Rock prices are net in that allowances for reduced quantities of earth are also included in the unit prices. The prices given include all costs for overhead, profit and rock surveys.
2. Wherever rock to be excavated is encountered, the Contractor shall strip or expose the rock to such an extent that in the Owner's opinion the necessary measurements can be taken. The Contractor shall provide the Owner with a survey by a licensed land surveyor indicating top of rock elevations at points of intersection on a rectilinear grid with lines spaced sufficiently close to show accurately the rock surface contours. At the Owner's option, an additional survey may be furnished by the Owner from a licensed surveyor.
3. If the conditions of the excavation work indicated are clearly of a special nature, the Contractor may ask the Owner for reconsideration of the established unit prices and if granted, the unit prices will not apply, and prices will be negotiated in accordance with Article 13 of the General Conditions.

**D. Definitions:**

1. "EARTH" - is defined, as excavation shall include removal of all materials other than 'water' and 'rock'.
2. "ROCK" - is defined as a boulder of 1 cubic yard or more in volume (1/2 cubic yard for a boulder in trenches), and rock in definite ledge formation and masonry structures of one cubic yard or more in volume, the removal of which requires the use of mechanical equipment or the use of explosives. Rock removed by scarification or ripping method is considered as a separate classification under paragraph 4.a.(1)
3. "ORIGINAL GRADE" - is defined as being the grade which exists at the time of Contract Award.
4. "ROUGH GRADE" - is defined as being the completed surface of required excavations greater than 13' in width.
5. "MASS" - excavation is to be considered as an open area whose minimum horizontal dimensions exceed 13'.
6. "TRENCH" - is defined as excavation is defined as the removal of material from areas 13 feet or less in its minimal horizontal dimensions and below the elevation of rough grade or original grade, whichever is lower.

**E. Procedures:**

1. Rock Excavation In Trenches: Basis For Horizontal Measurement:
  - a. Horizontal Measurements: Will be taken between the vertical planes as defined below.
  - b. The Minimum Width Of Trenches In Rock: Will be taken as 3' 0".
  - c. Excavation - For Walls Or Piers With Footings: The measurements will be taken parallel to and one foot outside of the edges of the concrete footings as called for in the plans (i.e. for 4' 0" footing, rock will be taken as 6' 0" in width).
  - d. Excavation For Walls Or Piers Without Footings: The limits of the excavation will be 1' 6" outside of the line of concrete at bottom as shown or called for in the plans (i.e. for a wall with a bottom thickness of 1' 0", the width of the trench will be considered to be 4' 0"). (Caissons are excluded from these measurements).
  - e. Excavation For Pipe Lines: Will be measured at 2' 0" more than the nominal inside diameter of the pipe but in no case less than 3' 0" wide.
  - f. Excavation For Tanks, Vaults, Manholes, Pits, Etc.: Will be measured as 2' 0" greater in both length and width or diameter than the actual exterior dimensions of the structures and this excavation is considered to be trench only if any measured horizontal dimensions is 13' or less.

- g. No allowance will be made for rock removed beyond the above limits.
2. Rock Excavation In Trenches - Basis for Vertical Measurement:
- a. To determine depth of trench, vertical measurements will be taken from original grade or rough grade, (whichever is applicable), to the bottom of required excavation. These measurements will define the maximum depths for payments.
- b. To determine quantity of rock in trench, vertical measurements will be taken from the top of rock as encountered in the trench to 12" below the bottom of required rock excavation. Any over excavation below the required elevation shall be filled with concrete or other material as specified at no cost to the Owner.
- c. No allowance will be made for rock removed beyond the above limits.
3. Earth Excavation In Trenches - Basis Of Measurement: (Horizontal & Vertical): The basis of measurements and allowance limit for earth excavation in trenches is identical to that indicated for rock excavation in trenches, except that there will be no allowance for 12" below the required elevation. In addition the following will prevail:

- a. Maximum allowable widths for earth excavation in trenches without shoring:

Trench Depth - Classification		Add To Nominal ID Of Pipe Or To Footing Width
	0 ft. - 6 ft.	3 ft.
Over	6 ft. - 10 ft.	5 ft.
Over	10 ft. - 15 ft.	7 ft.
Below 15 ft. deep the width of the trench shall be based on the individual case. The final depth of trench will determine the actual width for payment.		

- b. If shoring is required the measurement shall be taken between the exterior walls of the shoring not to exceed 4' plus the I.D. of the pipe (for all depths).
- c. To determine quantity of earth in trench, vertical measurements will be taken from the original or rough grade to actual bottom of earth excavation required.
4. Unit Prices - Earth and Rock Excavation (Basis For Payment): Prices include backfill with excavated material if it is suitable. Prices also include all excavation and disposal of all surplus or unsuitable material. Where replacement with the excavated material is prohibited or a particular backfill material is specified, the cost of the delivered replacement material in a volume equal to the above excavation pay limits minus the volume of the items installed in the trench shall be paid for a prior negotiated price. Prices do not include costs of shoring and de-watering but do include sloping for sides of excavation. Payment and credit amounts shall be determined in the following manner: Widths and depths of trench excavation as indicated. The total quantity of earth or rock excavation encountered in each depth payment category shall be paid for at its respective unit price as shown below. For example, in a 15' trench the first 6' will be paid for at the 0' - 6' price; the next 4' will be paid for at the over 6' - 10' price and the next 5' will be paid for at the over 10' - 15' price. Thus three different price brackets will prevail.

a.	EARTH EXCAVATION - HAND			UNIT	\$ ADD	\$ DEDUCT
	(1)	In Trenches - 0' - 6'.		C.Y.	36.00	28.80
	(2)	In Trenches Below 6' Deep,		Prices Must Be Negotiated Before Work Is Started.		
b.	EARTH EXCAVATION - MACHINE			UNIT	\$ ADD	\$ DEDUCT
	(1)	Open Area	All Depths	C.Y.	7.40	5.92
	(2)	In trenches	0' - 4' deep	C.Y.	4.25	3.40
		Over	0' - 10' deep	C.Y.	9.00	7.20
		Over	0' - 15' deep	C.Y.	4.75	3.80
		Over	0 - 20' deep	C.Y.	5.75	4.60
c.	ROCK EXCAVATION			UNIT	\$ ADD	\$ DEDUCT
	(1)	Open Areas, Rock Removed By Ripping (Any Amount),				

**DIVISION 1  
GENERAL REQUIREMENTS  
PAGE 8 of 45**

		Net Rock		C.Y.	9.20	7.30
	(2)	Open Areas, With Explosives -				
		Net Rock -	Total Quantity Up To 100	C.Y.	27.00	21.60
			Total Quantity Up To 500	C.Y.	21.30	17.00
c.	ROCK EXCAVATION (cont.)			UNIT	\$ ADD	\$ DEDUCT
			Total Quantity Up To 500 or more	C.Y.	17.00	13.60
	(3)	In Trenches, Boulders, Remove By Machine		C.Y.	14.00	11.20
	(4)	In Trenches, Ripping Of Rock By Machine		C.Y.	16.00	12.80
	(5)	In trenches, with explosives				
		Net Rock	0' - 4' Deep	C.Y.	20.60	16.48
	(6)	In trenches, with explosives				
		Net Rock	0' - 10' Deep	C.Y.	36.75	29.40
	(7)	In trenches, with explosives				
		Net Rock	0 - 15' Deep	C.Y.	28.60	22.88
	(8)	In trenches, with explosives				
		Net Rock	Over 15' - 10' Deep	C.Y.	60.00	48.00
	(9)	In trenches, with explosives -				
		Net Rock	0 - 20' Deep,	Prices Must Be Negotiated Before Start Of Work.		
	(10)	Jack Holes (For Hydraulic Lift/Elevators)		L.F.	95.00	76.00
	(11)	Open Or Mass Areas - If Explosives Are Prohibited				
		Net Rock		C.Y.	80.00	64.00
	(12)	Trench Excavation - If Explosives Are Prohibited				
		Net Rock/With Rock Splitters And Jack Hammer or Hoe Ram		C.Y.	120.00	96.00

**F. Unit Price Schedule – Miscellaneous:**

1. Unit Price - Miscellaneous:

A.	MISCELLANEOUS Items	UNIT	\$ ADD	\$ DEDUCT
	a. *Structural fill			
	b. *Footing forms, contact area			
	c. *Footing concrete, in place			
	d. *Wall forms, contact area			
	e. *Wall concrete, in place			
	f. *Reinforcing steel bars, in place			
	g. *Structural steel, in place			

**G. Unit Price Schedule - Alterations**

1. Unit Price - Alterations:

A.	ALTERATION ITEMS	UNIT	\$ ADD	\$ DEDUCT
	a. Roof Blocking			
	b. Roof Planking			
	c. Flashing			
	d. Roof Sheathing			
	e. Roof Flashing			
	f. Structural Deck			

	g. Roof Drain Assemblies			
--	--------------------------	--	--	--

2. Unit prices shall be negotiated if there is a change in scope of work.

---

**01027 APPLICATION FOR PAYMENT**

---

- A. Schedule of Values:** Submit the “Schedule of Values” to the Construction Administrator at the earliest possible date but no later than (21) twenty Calendar Days after the Contract Start Date. A separate "Schedule of Value" shall be provided for each Phase of identified in Section 01010 Summary of Work, Work Sequence - Phase(s).
1. **Format and Content:** Use the Project Manual Table of contents as a guide to establish the format for the “Schedule of Values”. Provide at least one line item for each of the Specification Section on electronic media printout.
  2. **Identification:** Project identification on the Schedule of Values shall include, but not be limited to, the following:
    - a. Owner
    - b. Project Number
    - c. Project Name
    - d. Project Location
    - e. Contractor's name and address.
  3. Arrange the “Schedule of Values” in tabular format as required by the Owner, containing separate columns including, but not limited to, the following Items:
    - a. Item Number.
    - b. Description of Work with Related Specification Section or Division Number.
    - c. Scheduled Values broken down by description number, type material, units of each material.
    - d. Name of subcontractor.
    - e. Name of manufacturer or fabricator.
    - f. Name of supplier.
    - g. Retainage.
    - h. Contract sum in sufficient detail.
  4. Percentage of Contract Sum to nearest one-hundredth percent, adjusted to total 100 percent.
  5. Provide a breakdown of the Contract Sum in sufficient detail to facilitate continued evaluation of Applications for Payment and progress reports. Coordinate with the Project Manual table of contents. Break principal subcontract amounts down into several line items.
  6. Round amounts to nearest whole dollar; the total shall equal the Contract Sum.
  7. **Unit-Cost Allowances:** Show the line-item value of unit-cost allowances, as a product of the unit cost, multiplied by the measured quantity. Estimate quantities from the best indication in the Contract Documents.
  8. **General Conditions:** Show line items for indirect costs and margins on actual costs only when such items are listed individually in Applications for Payment. Each item in the Schedule of Values and Applications for Payment shall be complete. Include the total cost and proportionate share of general overhead and profit margin for each item.
    - a. Temporary facilities and other major cost items that are not direct cost of actual work-in-place may be shown either as separate line items in the Schedule of Values or distributed as general overhead expense, at the Contractor's option.
- B Applications for Payment - General:** Each Application for Payment shall be consistent with previous applications and payments as certified by the Architect and Construction Administrator and paid for by the Owner.

1. The initial “Application for Payment”, the “Application for Payment”, at time of “Substantial Completion”, and the final “Application for Payment”, involve additional requirements.
2. Payment-Application Terms: The Owner will process monthly progress payments. The Contractor may submit applications for payment on a monthly basis.
3. Payment-Application Forms: Use the “Application for Payment” form as required by the Owner. Present the required information on electronic media printout or approved Owner Form, multiple pages should be used if required.
4. For each item, provide a column including but not limited to the following items:
  - a. *Item Number.*
  - b. *Description of Work and Related Specification Section or Division.*
  - c. *Scheduled Value, break down by units of material and units of labor.*
  - d. *Work completed from previous application.*
  - e. *Work completed this period.*
  - f. *Materials presently stored.*
  - g. *Total completed and stored to date of application.*
  - h. *Percentage of Completion.*
  - i. *Balance to Finish.*
  - j. *Retainage*
5. Application Preparation: Complete every entry on the form. Include final payment only and execution by a person authorized to sign legal documents on behalf of the Contractor. The Construction Administrator will return incomplete applications without action.
  - a. Entries shall match data on the “Schedule of Values”.
  - b. Include amounts of Change Orders issued prior to the last day of the construction period covered by the application.
6. Transmittal: Submit **3** signed and notarized original copies of each Application for Payment to the Construction Administrator. One copy shall be complete, including waivers of lien and similar attachments, when required.
  - a. Transmit each copy with a transmittal form listing attachments and recording appropriate information related to the application, in a manner acceptable to the Architect.
7. Applications for Payment: Administrative actions and submittals, that must precede or coincide with submittal of the first Application for Payment and all subsequent Application for Payments including, but not limited to, the following items:
  - a. *List of subcontractors and suppliers’ name, FEIN/Social Security numbers, and Connecticut Tax Registration Numbers.*
  - b. *List of principal suppliers and fabricators.*
  - c. *Schedule of Values.*
  - d. *Contractor's Construction Schedule (preliminary if not final).*
  - e. *Schedule of principal products.*
  - f. *Submittal Schedule (preliminary if not final).*
  - g. *List of Contractor's staff assignments.*
  - h. *List of Contractor's principal consultants.*
  - i. *Copies of all applicable permits.*
  - j. *Copies of authorizations and licenses from governing authorities for performance of the Work.*
  - k. *Initial as-built survey and damage report, if required.*

- C. Application for Payment at Substantial Completion:** Following issuance of the Certificate of Substantial Completion submit an Application for Payment form, use the form as required by the Owner. Present the required information on electronic media printout.
1. This application shall reflect Certificates of Partial Substantial Completion issued previously for Owner occupancy of designated portions of the Work..
  2. Administrative actions and submittals that shall precede or coincide with this application include, but are not limited to, the following:
    - a. *Occupancy permits and similar approvals.*
    - b. *Warranties (guarantees) and maintenance agreements.*
    - c. *Test/adjust/balance records.*
    - d. *Maintenance instructions.*
    - e. *Meter readings.*
    - f. *Startup performance reports.*
    - g. *Changeover information related to Owner's occupancy, use, operation, and maintenance.*
    - h. *Final cleaning.*
    - i. *Application for reduction of retainage and consent of surety.*
    - j. *Advice on shifting insurance coverage.*
    - k. *Final progress photographs.*
    - l. *List of incomplete Work, recognized as exceptions to Architect's Certificate of Substantial Completion.*

- D. Final Payment Application:** Administrative actions and submittals that must precede or coincide with submittal of the final Application for Payment include, but are not limited, to the following:

Completion, Final Inspection, and Final Payment, in the General Conditions and Supplementary Conditions.

1. *Completion of Project Closeout requirements.*
2. *Completion of list of items remaining to be completed as indicated on the attachment to the Certificate of Substantial Completion.*
3. *Ensure that unsettled claims will be settled.*
4. *Ensure that incomplete Work is not accepted and will be completed without undue delay.*
5. *Transmittal of required Project construction records to the Owner.*
6. *Certified property survey.*
7. *Proof that taxes, fees, and similar obligations were paid.*
8. *Removal of temporary facilities and services.*
9. *Removal of surplus materials, rubbish, and similar elements.*
10. *Change of door locks to Owner's access.*
11. *The requirements of the General Conditions and Supplementary Conditions for Final Acceptance, Final Completion, Final Inspection, and Final Payment.*
12. *Asbestos, Lead or other hazardous material manifests.*
13. *Completion of "Building Contractor Reporting Form" as supplied by Department of Public Works, for all Contractors, Subcontractors, Vendors, Suppliers, etc. who work on the Contract. The form includes the following information:*
  14. *Contractor/Subcontractor name.*
  15. *FEIN/Social Security Numbers*
  16. *Connecticut Tax Registration Numbers*
  17. *Type of work*

18. *Name of business and address*

19. *Remittance address.*

---

**01030 SUPPLEMENTAL BIDS**

---

**A. Definition:** A Supplemental Bid is an amount proposed by bidders and stated on the Bid Proposal Form for certain work defined in the Bidding Documents that may be added to the Base Bid amount if the Owner decides to accept a corresponding change in either the amount of construction to be completed, or in the products, materials, equipment, systems, or installation methods described in the Contract Documents.

1. The cost for each supplemental bid is the net addition to the Contract Sum to incorporate the Supplemental Bid into the Work. Supplemental Bids are only accepted in the numerical order that they are listed on the Bid Proposal Form and never accepted out of numerical sequence. No other adjustments are made to the Contract Sum.

**B. Procedures:**

1. Coordination: Modify or adjust affected adjacent Work as necessary to completely and fully integrate that Work into the Project.
  - a. Include as part of each Supplemental Bid, miscellaneous devices, accessory objects, and similar items incidental to or required for a complete installation whether or not mentioned as part of the Supplemental Bid.
2. Execute accepted Supplemental Bids under the same conditions as other Work of this Contract.
2. Schedule: A "Schedule of Supplemental Bids" is included at the end of this Section. Specification Sections referenced in the Schedule contain requirements for materials necessary to achieve the Work described under each Supplemental Bid.

**C. Schedule of Supplemental Bids:**

1. *Supplemental Bid – Add Alternate #1: Consists of the modifications to the irrigation system for the Rugby field.*
2. *Supplemental Bid – Add Alternate #2: Consists of additional sod installation for the Baseball field.*

---

**01035 MODIFICATION PROCEDURES**

---

**A. Summary:** This Section specifies administrative and procedural requirements for handling and processing contract modifications.

**B. Minor Changes in the Work:**

1. The Architect, through the Construction Administrator, will issue supplemental instructions authorizing Minor Changes in the Work, not involving adjustment to the Contract Sum or Contract Time, on the "Supplemental Instructions" form as required by the Owner.

**C. Proposal Request:**

1. Architect/Owner-Initiated Requests For Proposals: The Architect or Owner will issue a detailed description of proposed changes in the Work via the Construction Administrator that will require adjustment to the Contract Sum or Contract Time. If necessary, the description will include supplemental or revised Drawings and Specifications. Such requests shall be on a "Proposal Request" form as required by the owner.
2. "Proposal Request" is issued for information only. Do not consider them as an instruction either to stop work in progress or to execute the proposed change.
3. Within Fourteen (14) Calendar Days of receipt of a "Proposal Request", submit a "Change Order Proposal" with the required information necessary to execute the change to the Construction Administrator for the Architect's/Owner's review.
4. Include a list of quantities of products required and unit costs, with the total amount of purchases to be made. Where requested, furnish survey data to substantiate quantities.

- a. Indicate applicable delivery charges, equipment rental, and amounts of trade discounts.
- b. Include a statement indicating the effect the proposed change in the Work will have on the Contract Time.
- c. The Agency is tax exempt. All Contractor and Subcontractor services provided under your contract with the State of Connecticut may not be exempt from taxes. The Department of Revenue Services can guide you as to which services are exempt and which are not. Please contact the State of Connecticut, Department of Revenue Services at 1-800-382-9463 or 566-7033.
- d. Dollar values shown on the Schedule of Values shall not be the governing (or deciding) final amounts for change orders involving either additional charges or deletions.

**D. Requests for Information:**

1. In the event that the contractor or subcontractor, at any tier, determines that some portion of the drawings, specifications, or other contract documents requires clarification or interpretation by the Architect, the contractor shall submit a "Request for Information" in writing to the Architect via Construction Administrator. "Requests for Information" may only be submitted by the contractor and shall only be submitted on the "Request for Information" forms as required by the owner. In the "Request for Information", the contractor shall clearly and concisely set forth the issue for which clarification or interpretation is sought and why a response is needed from the Architect.
  - a. In the "Request for Information", the contractor shall set forth an interpretation or understanding of the requirement along with reasons why such an understanding was reached.
  - b. The owner acknowledges that this is a complex project. Based upon the owner's past experience with projects of similar complexity, the owner anticipates that there will probably be some "Requests for Information" on this project.
  - c. The Architect will review all "Requests for Information" to determine whether they are "Requests for Information" within the meaning of this term. If it is determined that the document is not a "Request for Information", it will be returned to the contractor, unreviewed as to content, for resubmittal on the proper form and in the proper manner.
  - d. A "Requests for Information Response" shall be issued within seven (7) Calendar Days of receipt of the request from the contractor unless the owner determines that a longer time is necessary to provide an adequate response. If a longer time is determined necessary by the owner, the owner will, within seven (7) Calendar Days of receipt of the request, notify the contractor of the anticipated response time. If the contractor submits a "Request for Information" on an activity with seven (7) Calendar Days or less of float on the current project schedule, the contractor shall not be entitled to any time extension due to the time it takes the Architect to respond to the request provided that the Architect responds within the seven (7) Calendar Days set forth above.
  - e. A "Requests for Information Response" from Architect will not change any requirement of the contract documents. In the event the contractor believes that the "Requests for Information Response" will cause a change to the requirements of the contract document, the contractor shall immediately give written notice to the Construction Administrator stating that the contractor believes the "Requests for Information Response" will result in "Change Order" and the Contractor intends to submit a "Change Order Proposal" request. Failure to give such written notice immediately shall waive the contractor's right to seek additional time or cost under the requirement these Requirements.

**E. Change Order Proposal:**

1. When either a "Request for Information" from the Contractor or a "Proposal Request" from the Architect or Owner results in conditions that may require modifications to the Contract, the Contractor may propose changes by submitting a request for a "Change Order Proposal" to the Architect via the Construction Administrator on forms as required by the Owner. These forms shall also include "Change Order Proposal Worksheets" as required by the Owner.
  - a. Include statements outlining the reasons for the change and the effect of the change on the Work. Provide a complete description of the proposed change. Indicate the effect of the proposed change on the Contract Sum and Contract Time.

- b. Include a list of quantities of products required and unit costs, with the total amount of purchases to be made. Where requested, furnish survey data to substantiate quantities as directed by Article 13 of the General Conditions of the Contract for Construction.
  - c. Indicate applicable delivery charges, equipment rental, and amounts of trade discounts.
  - d. Comply with requirements in Section 01631 Equals and Substitutions if the proposed change requires an equal or substitution of one product or system for a product or system specified.
2. The State of Connecticut construction contract has the following tax exemptions:
    - a. Purchasing of materials which will be physically incorporated and become a permanent part of the project.
    - b. Tools, supplies and equipment used in fulfilling the construction contract are not exempt.
    - c. Services that are resold by the contractor are exempt, i.e. if a General Contractor hires a plumber, carpenter or electrician, a resale certificate may be issued to the subcontractor because these services are considered to be integral and inseparable component parts of the building contract
  3. "Change Order Request" Forms: Use "Change Order Proposal" and "Change Order Proposal Worksheets" forms as required by Owner.
  4. "Change Order Proposal" cannot be submitted without the Contractor either prior submission of a "Request for Information" from the Contractor or as a response to a "Proposal Request" submitted by the Architect or Owner.
  5. Any "Change Order Request" submitted without a prior submittal of a "Request for Information" or as a response to a "Proposal Request" will be immediately rejected and returned to the Contractor.

**F. Construction Change Directive:**

1. "Construction Change Directive": When the Owner and the Contractor disagree on the terms of a "Change Order Proposal" resulting from either a "Request for Information" or "Proposal Request", then the Architect through the Construction Administrator may issue a "Construction Change Directive" on a "Construction Change Directive" as authorized by the Owner on the form required by the Owner. The "Construction Change Directive" instructs the Contractor to proceed with a change in the Work, for subsequent inclusion in a "Change Order".
  - a. The "Construction Change Directive" contains a complete description of the change in the Work. It also designates the method to be followed to determine change in the Contract Sum or Contract Time.
2. Documentation: The Contractor shall maintain detailed records on a time and material basis of work required by the "Construction Change Directive".
  - a. After completion of the change, submit an itemized account and supporting data necessary to substantiate cost and time adjustments to the Contract.
  - b. The final value shall be negotiated based on the supporting data to determine the value of the work.

**G. Change Order Procedures:**

1. Upon the Owner's approval of a Contractor's "Change Order Proposal", the Construction Administrator will issue a "Change Order" for signatures of the Architect, Owner and the Contractor on "Change Order" form as required by the Owner.

---

**01040 COORDINATION**

---

**A. Construction Administrator:**

1. The Construction Administrator is identified in Section 01003 Construction Administrator.
2. Construction Mobilization:
  - a. Cooperate with the Construction Administrator in the allocation of mobilization areas of the site, for field offices and sheds, for agency facility access, traffic, and parking facilities.
  - b. During Construction, coordinate use of site and facilities through the Construction Administrator.

- c. Comply with Construction Administrators procedures for intra-project communications; submittals, reports and records, schedules, coordination drawings, and recommendations; and resolution of ambiguities and conflicts.
  - d. Comply with instructions of the Construction Administrator for use of temporary utilities and construction facilities.
  - e. Coordinate field engineering layout as specified in Section 01050 "Field Engineering" for work under the instructions of the Construction Administrator.
- B** Coordinate construction operations included in various Sections of these Specifications to assure efficient and orderly installation of each part of the Work. Coordinate construction operations included under different Sections that depend on each other for proper installation, connection, and operation.
- 1. Schedule construction operations in the sequence required to obtain the best results where installation of one part of the Work depends on installation of other components, before or after its own installation.
  - 2. Coordinate installation of different components to assure maximum accessibility for required maintenance, service, and repair.
  - 3. Make provisions to accommodate items scheduled for later installation.
- C.** Where necessary, prepare memoranda for distribution to each party involved, outlining special procedures required for coordination. Include such items as required notices, reports, and attendance at meetings.
- 1. Prepare similar memoranda for the Construction Administrator, Owner and separate contractors where coordination of their work is required.
- D. Administrative Procedures:** Coordinate scheduling and timing of required administrative procedures with other construction activities to avoid conflicts and assure orderly progress of the Work. Such administrative activities include, but are not limited to, the following:
- 1. *Preparation of schedules.*
  - 2. *Installation and removal of temporary facilities.*
  - 3. *Delivery and processing of submittals.*
  - 4. *Progress meetings.*
  - 5. *Project closeout activities.*
- E. General Coordination Provisions:**
- 1. **Inspection of Conditions:** Require the Installer of each major component to inspect both the substrate and conditions under which Work is to be performed and coordinate such inspections with the Construction Administrator and authorities having jurisdictions. If unsatisfactory conditions exist notify the Construction Administrator immediately. Do not proceed until unsatisfactory conditions have been corrected in an acceptable manner.
  - 2. The Contractor shall coordinate temporary enclosures with required inspections and tests to minimize the necessity of uncovering completed construction for that purpose.
  - 3. **Coordination Drawings:**
    - a. The HVAC Subcontractor will initiate mylar at 1/4" scale drawings done on AutoCAD showing ducts and piping in plan and section. Sheet metal shop drawings must be approved prior to starting coordination drawings.
    - b. The Sprinkler Subcontractor will then superimpose his piping layout on the tracing.
    - c. The Electrical subcontractor will superimpose all the electrical information on the tracing. Said information to include but not necessary limited to cable trays, equipment, lighting, conduits, bus duct, etc.
    - e. The sprinkler subcontractor will complete the coordination drawing by drawing his piping (include pitch) on the tracing.
    - f. The Construction Administrator will review the completed coordination drawing for general compliance and then submit it to the Architect for his review. All subcontractors shall rework the mylar drawings until all systems are properly coordinated.

4. The Construction Administrator will meet with the Contractor on all major items of coordination.
5. See also General Conditions Article 7.

---

**01045 CUTTING AND PATCHING (NOT APPLICABLE)**

---

- A. Openings and chases may not be shown on the Drawings. It is the responsibility of the Contractor to examine the Architectural, Electrical, Heating, Cooling, Ventilating and Plumbing Drawings and to provide chases, channels or openings where needed.
- B. The Contractor shall install sleeves, inserts and hangers furnished by the trades needing same.
- C. After installing work into openings, channels and/or chases, the Contractor shall close same. If finishes are to be restored, the new work shall match the original and shall be done by the trade customarily responsible for the particular kind of work.
- D. Permission shall be obtained from the Construction Administrator before cutting beams, arches, lintels or other structural members.
- E. Requirements for Structural Work: Do not cut and patch structural elements in a manner that would change their load-carrying capacity or load-deflection ratio.
  1. Obtain approval from the Architect/Engineer's of the cutting and patching proposal before cutting and patching the following structural elements:
    - a. *Foundation construction.*
    - b. *Bearing and retaining walls.*
    - c. *Structural concrete.*
    - d. *Structural steel.*
    - e. *Lintels.*
    - g. *Structural decking.*
    - i. *Miscellaneous structural metals.*
    - j. *Exterior curtain-wall construction.*
    - k. *Equipment supports.*
    - l. *Piping, ductwork, vessels, and equipment.*
    - m. *Structural systems of special construction in Division 13 Sections.*
- F. Do cutting and patching to integrate all elements of the work. Provide penetrations of existing surfaces. Provide samples for testing. Seal penetrations through floors, walls, ceilings and roofs, as applicable; restore or preserve fire-rated and smoke-barrier construction. Construction and finishes shall match original work.
- G. The Contractor shall verify dimensions for built-in work and/or work adjoining that of other trades before ordering any material or doing any work. Discrepancies shall be submitted to the Construction Administrator before proceeding with the work.
- H. Existing Warranties: Replace, patch, and repair material and surfaces cut or damaged by methods and with materials in such a manner as not to void any warranties required or existing.
- I. See also General Conditions Article 23.

---

**01050 FIELD ENGINEERING**

---

- A. Provide field engineering services to establish and record grades, lines and elevations.
- B. The Contractor shall retain a Professional Engineer or Land Surveyor registered by the State of Connecticut to lay out the building, underground utility lines and other site work from the horizontal and vertical control information furnished by the Owner and to establish and record the necessary elevations, at no additional cost to the State.
- C. The Contractor shall forward a letter from his Land Surveyor or Professional Engineer stating that the control information furnished by the Owner, is accurate or shall identify inaccuracies, if they exist. The Contractor

shall not take advantage of errors, which may be included in the control information. Stakes and markings shall be preserved.

---

**01095 REFERENCE STANDARDS & DEFINITIONS**

---

- A. For products specified by association or trade standards, comply with requirements of the standard, except when more rigid requirements are specified or are required by applicable codes.
- B. References to standard specifications and codes refer to the editions current at the bid due date. An exception is, buildings exceeding the threshold limit must be in substantial compliance with the requirements of the effective code at the time of receipt of completed application to the Office of State Building Inspector (OSBI). References include their addenda and errata, if any, and shall be considered a part of these specifications as if they were printed herein in full.
- C. The manufacturers' standard warranties or guarantees shall apply when their products are used on this project.
- D. Flame Spread Ratings - all materials that are required or obligated to meet specified standards shall be submitted to the owner for their records as part of the shop drawing submittal process for their construction records.

---

**01120 RENOVATION/DEMOLITION PROJECT PROCEDURES**

---

**A. Products For Patching And Extending Work:**

- 1. New materials: As specified in product sections; match existing Products and Work for patching and extending Work.
- 2. Type and Quality of Existing Products: Determine by inspecting and testing Products where necessary, referring to existing Work as a standard.

**B. Inspection- General:**

- 1. Verify that demolition is complete and areas are ready for installation of new Work.
- 2. Beginning of restoration Work means acceptance of existing conditions.

**C. Project Procedures for Work Involving Asbestos Containing Material (ACM):**

- 1. The Construction Administrator is responsible for abating all ACM that is visible and accessible. This is to be accomplished through a separate project prior to the start of the renovation project. In demolition projects, every attempt should be by the owner to remove all ACM.
- 2. If the Contractor should encounter any material suspect or known to contain ACM, he should immediately notify the Construction Administrator of same. It is the State's responsibility to have the material tested and abated (if necessary). The Owner will respond within twenty-four (24) hours after receiving the Contractor's written request to the Construction Administrator for testing the suspect material. The Owner will abate ACM (if necessary) within a reasonable time period, i.e. with seven (7) Calendar Days.
- 3. Testing for asbestos has been conducted at the facility scheduled for renovation, demolition, reconstruction, alteration, remodeling, or repair. Results of the asbestos testing are for information purposes only. The testing results are in a separate Volume of this Project Manual. Under no circumstance shall this information be the sole means used by the Contractor for determining the extent of asbestos. The Contractor shall be responsible for verification of all field conditions affecting performance of the Work.
- 4. See also General Conditions Article 23.

**D. Project Procedures for Work Involving Lead Containing Material:**

- 1. Exposure levels for lead in the construction industry are regulated by 29 CFR 1926.62. Construction activities disturbing surfaces containing lead-based paint (LBP) which are likely to be employed, such as sanding, grinding, welding, cutting and burning, have been known to expose workers to levels of lead in excess of the Permissible Exposure Limit (PEL). Conduct demolition and removal Work specified in the technical sections of this specification in conformance with these regulations. In addition, construction debris/waste may be classified as hazardous waste. Disposal of hazardous waste material shall be in accordance with 40 CFR Parts 260 through 271 and Connecticut Hazardous Waste Management Regulations Section 22a-209-1; 22a-209-8(c); 22a-449(c)-11; and 22a-449(c)-100 through 110.

2. The Contractor's Work shall be based on a child under the age of six (6) in residence; the Work shall also be in accordance with Connecticut Regulations Section 19a-111-1 through 11.
3. This facility was constructed prior to 1978 and is likely to have painted surfaces containing lead-based paint.
4. Testing for lead-based paint has been conducted at the facility scheduled for renovation, demolition, reconstruction, alteration, remodeling, or repair. Results of the LBP testing are for information purposes only. The testing results are in a separate Volume of this Project Manual. Under no circumstance shall this information be the sole means used by the Contractor for determining the extent of LBP. The Contractor shall be responsible for verification of all field conditions affecting performance of the Work.

**E. Preparation:**

1. Cut, move, or remove items as are necessary for access to alterations and renovation Work. Replace and restore at completion.
2. Remove unsuitable material not marked for salvage, such as rotted wood, corroded metals, and deteriorated masonry and concrete. Replace materials as specified for finished Work.
3. Remove debris and abandoned items from area and from concealed spaces.
4. Prepare surface and remove surface finishes to provide for proper installation of new Work and finishes.
5. Close openings in exterior surfaces to protect existing Work and salvage items from weather and extremes of temperature and humidity. Insulate ductwork and piping to prevent condensation in exposed areas.

**F. Installation:**

1. Coordinate Work of alterations and renovations to expedite completion and if required sequence Work to accommodate Owner occupancy.
2. Remove, cut and patch Work in a manner to minimize damage and to provide restoring Products and finishes to original and or specified condition in accordance with Section 01045 "Cutting and Patching".
3. Refinish visible existing surfaces to remain in renovated rooms and spaces, to specified condition for each material, with neat transition to adjacent finishes in accordance with Section 01045 "Cutting and Patching".
4. In addition to specified replacement of *equipment* and *fixtures*, restore existing *plumbing, heating, ventilation, air conditioning, electrical*, systems to full operational condition.
5. Recover and refinish Work that exposes mechanical and electrical Work exposed accidentally during the Work.
6. Install Products as specified in individual sections.

**G. Transitions:**

1. Where new Work abuts or aligns with existing, perform a smooth and even transition. Patch work to match existing adjacent Work in texture and appearance.
2. When finished surfaces are cut so that a smooth transition with new Work is not possible, terminate existing surface along a straight line at a natural line of division and make recommendation to Architect/Engineer.

**H. Adjustments:**

1. Where removal of partitions or walls result in adjacent spaces becoming one, rework floors, walls, and ceilings to a smooth plane without breaks, steps, or bulkheads.
2. Where a change of plane of \_\_\_\_\_ inch in \_\_\_\_\_ or more occurs, request recommendation from Architect/Engineer for providing a smooth transition.
3. Trim existing doors as necessary to clear new floor finish. Refinish trim as required.
4. Fit Work at penetrations of surfaces as specified in Section 01045 "Cutting and Patching".

**I. Repair of Damaged Surfaces:**

1. Patch or replace portions of existing surfaces that are damaged, lifted, discolored, or showing imperfections.

2. Repair substrate prior to patching finish.

**J. Finishes:**

1. Finish surfaces as specified in individual Product sections.
2. Finish patches to produce uniform finish and texture over entire area. When finish cannot be matched, refinish entire surface to nearest intersections.

**K. Cleaning:**

1. In addition cleaning specified in Section 01700 "Project Closeout", clean Agency occupied areas of Work

---

**01121 SALVAGEABLE MATERIALS (NOT USED)**

---

- A. The Contractor shall be responsible for removing the following salvageable items from premises and transporting said items to the Grounds Department in the Facilities Management and Planning building.

---

**01200 PROJECT MEETINGS**

---

**A. Pre-construction Conference:**

1. The Contractor will attend a Pre-construction Conference before starting construction, as scheduled by the Construction Administrator convenient to the Owner, the Construction Administrator, Architect, and Contractor. This meeting will take place within fourteen (14) Calendar Days after the written Notice to Proceed and before the Contract Start Date. Hold the conference at the Project Site or another convenient location as directed by the Construction Administrator. The Construction Administrator shall conduct the Pre-construction Conference to review the Contractor and Subcontractor responsibilities and personnel assignments.
2. Attendees: Authorized representatives of the Construction Administrator, Owner, Architect, and their consultants; the Contractor and its superintendent; major subcontractors; agency; and other concerned parties shall attend the conference. All participants at the conference shall be familiar with the Project and authorized to conclude matters relating to the Work.
3. Agenda: Discuss items of significance that could affect progress, including the following:
  - a. *Tentative construction schedule.*
  - b. *Critical work sequencing.*
  - c. *Progress meeting schedule.*
  - d. *Designation of responsible personnel.*
  - e. *Procedures for processing field decisions and Change Orders.*
  - f. *Procedures for processing Applications for Payment.*
  - g. *Distribution of Contract Documents.*
  - h. *Submittal of Shop Drawings, Product Data, and Samples.*
  - i. *Preparation of record documents.*
  - j. *Use of the premises.*
  - k. *Parking availability.*
  - l. *Office, work, and storage areas.*
  - m. *Equipment deliveries and priorities.*
  - n. *Safety procedures.*
  - o. *First aid.*
  - p. *Security.*
  - q. *Housekeeping.*

- r. *Working hours.*
- s. *Coordination with Audio-Visual and Telecommunications.*

**B. Progress Meetings:**

1. The Construction Administrator will conduct progress meetings, bi-weekly, at the Project Site or at regular intervals as agreed upon at the Pre-construction Conference. The Construction Administrator will notify the Owner, the Architect, and the Contractor of the scheduled Progress Meeting dates. Coordinate dates of Progress Meetings with preparation of Application for Payment requests.
2. Attendees: In addition to representatives of the Contractor, Construction Administrator, Owner and the Architect, subcontractor, supplier, or other entity concerned with current progress or involved in planning, coordination, or performance of future activities may be requested to attend these meetings on an as needed basis. All participants at the meeting shall be familiar with the Project and authorized to conclude matters relating to the Work. The Contractor shall include the site superintendent as a minimum.
3. Agenda: Progress Meetings shall review and correct or approve minutes of the previous Progress Meeting. Review other items of significance that could affect progress. Include topics for discussion as appropriate to the status of the Project.
  - a. Construction Schedule: Review progress since the last Progress Meeting. Determine where each activity is in relation to the required Contractor's "Construction Schedule" and whether each activity is on time or ahead or behind Schedule. Determine how Work that is behind Schedule will be expedited; secure commitments from parties involved to do so. Discuss whether Schedule revisions are required to insure that current and subsequent activities will be completed within the Contract Time.
  - b. Review the present and future needs of each entity present
4. Reporting: The Construction Administrator will distribute minutes of the meeting to each party present, promptly and before the next scheduled meeting, and to parties who should have been present.
5. A schedule of regular Project Meetings will be established at the Pre-construction Conference.

---

**01300 SUBMITTALS**

---

**A. Summary:**

1. This Section includes administrative and procedural requirements for submittals required for performance of the Work, including but not limited to the following:
  - a. *Submittal schedule.*
  - a. Shop Drawings.
  - c. Product Data.
  - d. Samples.
  - e. Quality assurance submittals.
  - f. Proposed "Substitutions Request" form.
  - g. Warrantee samples.
  - h. Coordination Drawings.
  - i. O & M Manuals

**B. Administrative Submittals:** Refer to other Division 1 Sections and other Contract Documents for requirements for administrative submittals. Such submittals include, but are not limited to, the following:

1. Permits.
2. Applications for Payment.
3. Performance and payment bonds.
4. Contractor's construction schedule.
5. Daily construction reports.
6. Construction Photographs.

7. Insurance certificates.
8. List of subcontractors.
9. Subcontractors/Suppliers FEIN #'s and Connecticut tax registration #.

**C. Definitions:**

1. Coordination Drawings show the relationship and integration of different construction elements that require careful coordination during fabrication or installation to fit in the space provided or to function as intended and as identified in the Specification Division 2 through 16.
  - a. Preparation of Coordination Drawings is specified in Division 1 Section "Coordination" and may include components previously shown in detail on Shop Drawings or Product Data.
2. Field samples are full-size physical examples erected on-site to illustrate finishes, coatings, or finish materials. Field samples are used to establish the standard by which the Work will be judged.
3. Mockups are full-size assemblies for review of construction, coordination, testing, or operation; they are not Samples.

**D. Submittal Procedures:**

1. Coordination: Coordinate preparation and processing of submittals with performance of construction activities. Transmit each submittal sufficiently in advance of performance of related construction activities to avoid delay.
2. Coordinate each submittal with fabrication, purchasing, testing, delivery, other submittals, and related activities that requires sequential activity.
3. Coordinate transmittal of different types of submittals for related elements of the Work so processing will not be delayed by the need to review submittals concurrently for coordination.
4. The Architect reserves the right to withhold action on a submittal requiring coordination with other submittals until all related submittals are received.
5. The Architect reserves the right to reject incomplete submitted packages.
6. Processing: To avoid the need to delay installation as a result of the time required to process submittals, allow sufficient time for submittal review, including time for resubmittals.
  - a. Allow (2) two weeks for initial review. Allow additional time if the Architect must delay processing to permit coordination with subsequent submittals.
  - b. If an intermediate submittal is necessary, process the same as the initial submittal.
  - c. Allow (2) two for reprocessing each submittal.
  - d. No extension of Contract Time will be authorized because of failure to transmit submittals to the Architect sufficiently in advance of the Work to permit processing.

**E. Submittal Preparation:** Place a permanent label, title block or 8-1/2 inches x 11 inches cover page approved by the Architect, on each submittal for identification. Indicate the name of the entity that prepared each submittal on the label or title block.

1. The minimum number of copies required for each submittal shall be at a minimum 7 copies or as determine otherwise at the pre-construction conference or by the Construction Administrator.
2. Provide a space approximately 4 inches by 5 inches on the label, beside the title block or on the cover page on Shop Drawings to record the Contractor's review and approval markings and the action taken.
3. Include the following information on the label for processing and recording action taken.
  - a. *Project Name and State of Connecticut Project Number.*
  - b. *Date.*
  - c. *Name and address of the Architect, Construction Administrator, and Owner Representative.*
  - d. *Name and address of the Contractor.*
  - e. *Name and address of the subcontractor.*
  - f. *Name and address of the supplier.*

- g. Name of the manufacturer.*
  - h. Number and title of appropriate Specification Section.*
  - i. Drawing number and detail references, as appropriate.*
  - j. Indicate either initial or resubmittal.*
  - k. Indicate deviations from Contract Documents.*
  - l. Indicate if "equal" or "substitution".*
- F. Submittal Transmittal:** Package each submittal appropriately for transmittal and handling. Transmit each submittal from the Contractor to the Architect using a transmittal form. Copy the Construction Administrator on the transmittal. The Architect will return all submittals to the Contractor after action is taken with a complete copy of the submittal package and one complete copy of the submittal package. The Architect will not accept submittals received from sources other than the Contractor.
- 1. On the transmittal, record relevant information and requests for data. On the form, or separate sheet, record deviations from Contract Document requirements, including variations and limitations. Include Contractor's certification that information complies with Contract Document requirements.
- G Submittal Schedule:**
- 1. After development and review by the Owner and Architect acceptance of the Contractor's Construction Schedule prepare a complete schedule of submittals. Submit the schedule to the Construction Administrator within 30 days of Contract Award.
  - 2. Coordinate Submittal Schedule with the list of subcontracts, Schedule of Values, and the list of products as well as the Contractor's Construction Schedule
  - 3. Prepare the schedule in chronological order. Provide the following information:
    - a. Schedule date for the initial submittal.
    - b. Related section number.
    - c. Submittal category (Shop Drawings, Product Data, or Samples).
    - d. Name of Subcontractor.
    - e. Description of the part of Work covered.
    - f. Scheduled date for resubmittal.
    - g. Scheduled date for the Architect's final release of approval.
- H. Distribution:** Following response to the initial submittal, print and distribute copies to the Construction Administrator, Architect, Owner, subcontractors, and other parties required to comply with submittal dates indicated. Post copies in the Project meeting room and field office.
- 1. When revisions are made, distribute to the same parties and post in the same locations. Delete parties from distribution when they have completed their assigned portion of the Work and are no longer involved in construction activities.
- I. Schedule Updating:** Revise the schedule after each meeting or activity where revisions have been recognized or made. Issue the updated schedule concurrently with the report of each meeting.
- J. Daily Construction Reports**
- 1. Prepare a daily construction report recording the following information concerning events at the site, and submit duplicate copies to the Construction Administrator at weekly intervals:
    - a. List of subcontractors at the site.*
    - b. Approximate count of personnel at the site.*
    - c. High and low temperatures, general weather conditions.*
    - d. Accidents and unusual events.*
    - e. Meetings and significant decisions.*
    - f. Stoppages, delays, shortages, and losses.*

- g. Meter readings and similar recordings.*
- h. List of equipment on site and identify if idle or in use.*
- i. Orders and requests of governing authorities.*
- j. Change Orders received, start and end dates.*
- k. Services connected, disconnected.*
- l. Equipment or system tests and startups.*
- m. Partial Completion's, occupancies.*
- n. Substantial Completion's authorized.*
- o. Equals or Substitutions approved or rejected.*

**K. Shop Drawings:**

1. Submit newly prepared information drawn accurately to scale. Highlight, encircle, or otherwise indicate deviations from the Contract Documents. Do not reproduce Contract Documents or copy standard information as the basis of Shop Drawings. Standard information prepared without specific reference to the Project is not a Shop Drawing.
2. Shop Drawings include fabrication and installation Drawings, setting diagrams, schedules, patterns, templates and similar Drawings. Include the following information:
  - a. Dimensions:
  - b. Identification of products and materials included by sheet and detail number.
  - c. Compliance with specified standards.
  - d. Notation of coordination requirements.
  - e. Notation of dimensions established by field measurement.
  - f. Sheet Size: Except for templates, patterns and similar full-size Drawings, submit Shop Drawings on sheets at least 8-1/2 by 11 inches but no larger than 36 by 48 inches.
  - g. Submit one (1) reproducible media and seven (7) prints as directed by the Construction Administrator. The Contractor's submittal shall identify the specification section and/or drawing number applicable to the submittal.
  - h. Details shall be large scale and/or full size.
3. The Contractor shall review the Shop Drawings, stamp with this approval, and submit them with reasonable promptness and in orderly sequence so as to cause no delay in his Work or in the Work of any subcontractor. Shop Drawings shall be properly identified as specified for item, material, workmanship, and project number. At the submission, the Contractor shall inform the Architect, in writing of any deviation in the shop drawings from the requirements of the Contract Documents.
4. The Architect will review and comment on shop drawings with reasonable promptness so as to cause no delay, but only for conformance with the design concept of the project and with the information given in the Contract Documents. Refer to Article 5 of General Conditions. Shop Drawings received by the Architect that indicate insufficient study of drawings and specifications, illegible portions or gross errors, will be rejected outright. Such rejections shall not constitute an acceptable reason for granting the Contractor additional time to perform the work.
5. The Contractor shall make any corrections required by the Architect and shall resubmit the required number of corrected copies of shop drawings until fully reviewed.
6. Upon final review submit four (4) additional prints, same as submitted, to the Construction Administrator for his use.
7. The Architect's review and comments on shop drawings shall not relieve the Contractor of responsibility for any deviation from the requirements of the Contract Documents.
8. Only final reviewed shop drawings are to be used on the project site.

9. The Work installed shall be reviewed in accordance with the shop drawings and the drawings and specifications. Final Review of the shop drawings by the Architect shall constitute acceptance by the State and the Architect of a variation or departure that is clearly identified. Final reviewed shop drawings shall not replace or be used as a vehicle to issue or incorporate change orders.

**L. Product Data:**

1. Collect Product Data into a single submittal for each element of construction or system. Product Data includes printed information, schedules, such as manufacturer's installation instructions, catalog cuts, standard color charts, roughing-in diagrams and templates, standard wiring diagrams, and performance curves.
2. Mark each copy to show applicable choices and options. Where printed Product Data includes information on several products that are not required, mark copies to indicate the applicable information. Include the following information:
  - a. *Manufacturer's printed recommendations.*
  - b. *Compliance with trade association standards.*
  - c. *Compliance with recognized testing agency standards.*
  - d. *Application of testing agency labels and seals.*
  - e. *Notation of dimensions verified by field measurement.*
  - f. *Notation of coordination requirements.*
3. Do not submit Product Data until compliance with requirements of the Contract Documents has been confirmed.
4. Preliminary Submittal: Submit a preliminary single copy of Product Data where selection of options is required.
5. Submittals: Submit 7 copies of each required submittal; submit 5 copies where required for maintenance manuals. The Architect will retain one and will return the other marked with action taken and corrections or modifications required.
  - a. Unless noncompliance with Contract Document provisions is observed, the submittal may serve as the final submittal.
6. Distribution: Furnish copies of final submittal to installers, subcontractors, suppliers, manufacturers, fabricators, and others required for performance of construction activities. Show distribution on transmittal forms.
  - a. Do not proceed with installation until a copy of Product Data is in the Installer's possession.
  - b. Do not permit use of unmarked copies of Product Data in connection with construction.

**M. Samples:**

1. Submit full-size, fully fabricated Samples cured and finished as specified and physically identical with the material or product proposed. Samples include partial sections of manufactured or fabricated components, cuts or containers of materials, color range sets, and swatches showing color, texture, and pattern.
2. Store, mount or display Samples on site in the manner to facilitate review of qualities indicated. Prepare Samples to match the Architect's sample. Include the following:
  - a. *Specification Section number and reference.*
  - b. *Generic description of the Sample.*
  - c. *Sample source.*
  - d. *Product name or name of the manufacturer.*
  - e. *Compliance with recognized standards.*
  - f. *Availability and delivery time.*

3. Submit Samples for review of size, kind, color, pattern, and texture. Submit Samples for a final check of these characteristics with other elements and a comparison of these characteristics between the final submittal and the actual component as delivered and installed.
  - a. Where variation in color, pattern, texture, or other characteristic is inherent in the material or product represented, submit at least three (3) multiple units that show approximate limits of the variations.
  - b. Refer to other Specification Sections for requirements for Samples that illustrate workmanship, fabrication techniques, details of assembly, connections, operation, and similar construction characteristics.
  - c. Refer to other Sections for Samples to be returned to the Contractor for incorporation in the Work. Such Samples must be undamaged at time of use. On the transmittal, indicate special requests regarding disposition of Sample submittals.
  - d. Samples not incorporated into the Work, or otherwise designated as the Owner's property, are the property of the Contractor and shall be removed from the site prior to Substantial Completion.
4. Preliminary Submittals: Submit a full set of choices where Samples are submitted for selection of color, pattern, texture, or similar characteristics from a range of standard choices, unless otherwise noted in specification section.
  - a. The Architect will review and return preliminary submittals with the Architects notation, indicating selection and other action.
5. Submittals: Except for Samples illustrating assembly details, workmanship, fabrication techniques, connections, operation, and similar characteristics, submit three (3) sets. The Architect will return one set marked with the action taken.
6. Maintain sets of Samples, as returned, at the Project Site, for quality comparisons throughout the course of construction.
  - a. Unless noncompliance with Contract Document provisions is observed, the submittal may serve as the final submittal.
  - b. Sample sets may be used to obtain final acceptance of the construction associated with each set.
7. Distribution of Samples: Prepare and distribute additional sets to subcontractors, manufacturers, fabricators, suppliers, installers, and others as required for performance of the Work. Show distribution on transmittal forms.
  - a. Field samples are full-size examples erected on-site to illustrate finishes, coatings, or finish materials and to establish the Project standard.

**N. Quality Assurance Submittals:**

1. Submit quality-control submittals, including design data, certifications, manufacturer's instructions, manufacturer's field reports, and other quality-control submittals as required under other Sections of the Specifications.
2. Certifications: Where other Sections of the Specifications require certification that a product, material, or installation complies with specified requirements, submit a notarized certification from the manufacturer certifying compliance with specified requirements.
  - a. Signature: Certification shall be signed by an officer of the manufacturer or other individual authorized to sign documents on behalf of the company.
3. Inspection and Test Reports: Requirements for submittal of inspection and test reports from independent testing agencies are specified in Division 1 Section "Quality Control."

**O. Architect's Action:**

1. Except for submittals for the record or information, where action and return is required, the Architect will review each submittal, mark to indicate action taken, and return promptly.
  - a. Compliance with specified characteristics is the Contractor's responsibility.
2. Action Stamp: The Architect will stamp each submittal with a uniform, action stamp. The Architect will mark the stamp appropriately to indicate the action taken, as follows:

- a. Final Unrestricted Release: When the Architect marks a submittal "Approved for fabrication," the Work covered by the submittal may proceed provided it complies with requirements of the Contract Documents. Final payment depends on that compliance.
  - b. Final-But-Restricted Release: When the Architect marks a submittal "Incorporate Notations," the Work covered by the submittal may proceed provided it complies with notations or corrections on the submittal and requirements of the Contract Documents. Submit corrected copies for record. Final payment depends on that compliance.
  - c. Returned for Resubmittal: When the Architect marks a submittal "Rejected, or Revise and Resubmit," do not proceed with Work covered by the submittal, including purchasing, fabrication, delivery, or other activity. Revise or prepare a new submittal according to the notations; resubmit without delay. Repeat if necessary to obtain different action mark.
    - i. Do not use, or allow others to use, submittals marked "Rejected, or Revise and Resubmit" at the Project Site or elsewhere where Work is in progress.
  - d. Other Action: Where a submittal is for information or record purposes or special processing or other activity, the Architect will return the submittal marked "Action Not Required."
3. Unsolicited Submittals: The Architect will discard unsolicited submittals without action.

---

**01310 CONSTRUCTION SCHEDULE**

---

**A. Definitions:**

1. Construction Schedule: A method of planning and scheduling a construction project utilizing a horizontal bar chart with a separate bar for each major portion of the Work or operation to make the schedule an effective tool for planning and monitoring the progress of the work

**B. Format:**

1. Format: Utilize a horizontal bar chart (ganttt) with a separate bar for each major portion of the Work or operation, identifying first work day of each week.
2. Program: Use **Microsoft Project**, latest version.
3. Sequence of Listings: Utilize the Table of Contents of this Project Manual and the chronological order of the start of each item of work.
4. Scale and Spacing: Provide space for notations and revisions.
5. Sheet Size: To be coordinated with Construction Administrator.

**C. Quality Assurance:** The Contractor's Consultant: Retain a consultant to provide planning, evaluating, and reporting by CPM scheduling.

1. In-House Option: The Owner may waive the requirement to retain a consultant if the Contractor can demonstrate that:
  - a. The Contractor has the computer equipment required to produce construction schedules.
  - b. The Contractor employs skilled personnel with experience in construction scheduling and reporting techniques.
2. Program: Use "**Microsoft Project**" compatible, latest version.
3. Standards: Comply with procedures contained in AGC's "Construction Planning & Scheduling."

**D. Content:**

1. Show complete sequence of construction by activity, with dates beginning and completion of each element of construction.
2. Identify each item by specification section number.
3. Identify work of separate phases other and other logically grouped activities.

4. Show accumulated percentages of completion of each item, and total percentage of Work completed, as of the first day of each month.
5. Provide separate schedule of submittal dates for shop drawings, product data, and samples, Owner/Agency furnished products and any products identified as under Allowances, and dates reviewed submittals will be required from Architect/Engineer. Indicate decision dates for selection of finishes.
6. Indicate delivery dates for Owner/Agency furnished products and any products identified as under Allowances.
7. Coordinate content with Schedule of Values specified in Section 01027.

**E. Submittals And Revisions To Schedules:**

1. Indicate progress of each activity to date of submittal, and projected completion date of each activity.
2. Identify activities modified since previous submittal, major changes in scope, other identifiable changes.
3. Provide narrative report to define problem areas, anticipated delays, and impact on Schedule. Report corrective action taken, or proposed, and its effect.
4. An initial bar graph (gant) schedule is to be prepared by the General Contractor and submitted to the Construction Administrator within seven (7) calendar days of award of contract. This schedule is to cover all items of work from the start of the project up to the completion of the project. After review, resubmit required revised data within five (5) calendar days. This schedule must be revised monthly and when the actual schedule of significant items varies more than one (1) week from the proposed schedule.
5. Submit revised Construction Schedules each Application for Payment.
6. Submit four (4) copies of the Construction Schedule to the Construction Administrator.

**F. Distribution:**

1. Distribute copies of the Construction Schedules to Construction Administrator, Architect, Owner, Subcontractors, suppliers, and other concerned parties.
2. Instruct recipients to promptly report, in writing, problem anticipated by projections indicated in schedules.

---

**01380 CONSTRUCTION PHOTOGRAPHS (NOT APPLICABLE)**

---

- A. On the date the work is begun and every thirty (30) days thereafter (until the work is at least 95 percent complete), the Contractor shall have photographs of the construction taken by a professional photographer.
- B. Take 24-35 mm color digital photos each time. Note on each photo frame the date the picture was taken and the project number. Deliver digital photographs to the Construction Administrator in both digital and hard copy form.
- C. As photographs are a record of the work progress, they shall be taken each month, whether or not they show work done during the preceding month. Deliver digital photos to the Construction Administrator, in both digital and hard copy form, within 10 days of their taking.

---

**01400 QUALITY CONTROL**

---

- A. **Contractor Responsibilities:** Unless otherwise indicated as the responsibility of another identified entity, the Owner, through the Construction Administrator, shall provide inspections, tests, and other quality-control services specified elsewhere in the Contract Documents and required by authorities having jurisdiction. All tests required by the individual specification sections are required to be scheduled and notification given to the Construction Administrator forty-eight (48) hours in advance to the test/inspection as applicable. Costs for these services are not included in the Contract Sum.
  1. Where individual Sections specifically indicate that certain inspections, tests, and other quality-control services are the Contractor's responsibility, the Contractor shall employ and pay a qualified independent testing agency to perform quality-control services. Costs for these services are included in the Contract Sum.

2. Where individual Sections specifically indicate that certain inspections, tests, and other quality-control services are the Owner's responsibility, the Owner will employ and pay a qualified independent testing agency to perform those services.
  - a. Such services include Special Inspections as required by the latest adoption of the "Connecticut State building Code".
  - b. Where the Owner has engaged a testing agency for testing and inspecting part of the Work, and the Contractor is also required to engage an entity for the same or related element, the Contractor shall not employ the entity engaged by the Owner. The Owner will engage the services of a qualified Special Inspector for this project. The Special Inspector, as a representative of the Owner, shall document and confirm compliance with the provisions of the Connecticut State Building Code for Special Inspections.
  - c. Materials and assemblers for this project will be tested and construction operations inspected as the work progresses. Failure to detect any defective work or material shall not in any way prevent later rejection when such defect is discovered nor shall it obligate the State for final acceptance.
  - d. The Owner use of testing and inspection services shall in no way relieve the contractor of the responsibility to furnish materials and finished construction in full compliance with the Contract Documents and the Connecticut State Building Codes.
- B. Retesting:** The Contractor is responsible for retesting where results of inspections, tests, or other quality-control services prove unsatisfactory and indicate noncompliance with Contract Document requirements, regardless of whether the original test was Contractor's responsibility.
  1. The cost of retesting construction, revised or replaced by the Contractor, is the Contractor's responsibility where required tests performed on original construction indicated noncompliance with Contract Document requirements.
  2. The Owner will issue a credit change order to cover all costs incurred related to all re-tests/re-inspection due to non-compliance to the contract documents, including but not limited to the Owners costs and the Consultants costs.
- C. Associated Services:** Cooperate with agencies performing required inspections, tests, and similar services, and provide reasonable auxiliary services as requested. Notify the agency sufficiently in advance of operations to permit assignment of personnel. Auxiliary services required include, but are not limited to, the following:
  1. Provide access to the Work.
  2. Furnish incidental labor and facilities necessary to facilitate inspections and tests.
  3. Take adequate quantities of representative samples of materials that require testing or assist the agency in taking samples.
  4. Provide facilities for storage and curing of test samples.
  5. Deliver samples to testing laboratories.
  6. Provide an approved design mix proposed for use for material mixes that require control by the testing agency.
  7. Provide security and protection of samples and test equipment at the Project Site.
- D. Duties of the Testing Agency:** The independent testing agency engaged to perform inspections, sampling, and testing of materials and construction specified in individual Sections shall cooperate with the Construction Administrator, Architect and the Contractor in performance of the testing agency's duties. The testing agency shall provide qualified personnel to perform required inspections and tests.
  1. The testing agency shall notify the Construction Administrator and the Contractor promptly of irregularities or deficiencies observed in the Work during performance of its services.
  2. The testing agency is not authorized to release, revoke, alter, or enlarge requirements of the Contract Documents or approve or accept any portion of the Work.
  3. The testing agency shall not perform any duties of the Contractor.

- E. Owner will pay for the services of an independent testing agency laboratory to perform inspections, tests and other services required by the Specifications except as noted below, listed for which the Owner will issue a deduct change order to cover the cost associated with these tests:
  - a) When the Contractor notifies the Construction Administrator and/or Testing Agency less than twenty-four (24) hours before the expected time of testing.
  - b) When the Contractor requires testing for his own convenience.
  - c) When the Contractor schedules a test and is not ready for the required test.
- F. Reports of test that are part of the submittal requirements which indicate compliance or non-compliance with the specified standard.
- G. See also General Conditions Article 16.

**H. Fire Alarm/Acceptance Testing Procedures:**

- 1. The Department of Public Works has been given the Authority Having Jurisdiction with regards to construction Projects which do not exceed Threshold Limit Laws. The Contractor shall follow the "Department of Public Works "Acceptance Testing Procedures" as provided by the Owner prior to Acceptance Testing.

**I. Submittals:**

- 1. Unless the Contractor is responsible for this service, the independent testing agency shall submit a certified written report, in duplicate, of each inspection, test, or similar service to the Construction Administrator. If the Contractor is responsible for the service, submit a certified written report, in duplicate, of each inspection, test, or similar service through the Contractor.
- 2. Submit additional copies of each written report directly to the governing authority, when the authority so directs.
- 3. Report Data: Written reports of each inspection, test, or similar service include, but are not limited to, the following:
  - a. Date of issue.
  - b. Project title and number.
  - c. Name, address, and telephone number of testing agency.
  - d. Dates and locations of samples and tests or inspections.
  - e. Names of individuals making the inspection or test.
  - f. Designation of the Work and test method.
  - g. Identification of product and Specification Section.
  - h. Complete inspection or test data.
  - i. Test results and an interpretation of test results.
  - j. Ambient conditions at the time of sample taking and testing.
  - k. Comments or professional opinion on whether inspected or tested Work complies with Contract Document requirements.
  - l. Name and signature of laboratory inspector.
  - m. Recommendations on re-testing.

**J. Quality Assurance:**

- 1. Qualifications for Service Agencies: Engage inspection and testing service agencies, including independent testing laboratories, that are pre-qualified as complying with the National Voluntary Laboratory Accreditation Program and that specialize in the types of inspections and tests to be performed.
  - a. Each independent inspection and testing agency engaged on the Project shall be authorized by authorities having jurisdiction to operate in the state where the Project is located.

**K. Repair and Protection:**

1. General: Upon completion of inspection, testing, sample taking and similar services, repair damaged construction and restore substrates and finishes. Comply with Contract Document requirements for Division 1 Section "Cutting and Patching."
2. Protect constructions exposed by or for quality-control service activities, and protect repaired construction.
3. Repair and protection is Contractor's responsibility, regardless of the assignment of responsibility for inspection, testing, or similar services.

---

**01505 TEMPORARY ELECTRICITY AND LIGHTING (NOT APPLICABLE)**

---

- A. Power and lighting may be taken from the power company's nearest pole with temporary poles, if needed, to extend the line to project. If permanent power lines have been installed before beginning project, then temporary lines can be brought in from the last pole.
- B. Provide service required for construction with branch wiring and distribution boxes located to provide power and lighting by construction-type extension cords. Meter shall be provided and installed by the Contractor.
- C. All costs of temporary power and light shall be paid by the Contractor.
- A. Connect to existing service, provide branch wiring and distribution boxes located to provide power and lighting by construction-grade extension cords. Owner will pay cost of energy used. Take measures to conserve energy. Provide lighting for construction operations. At the termination of construction, return the facilities to their original condition.

---

**01510 TEMPORARY HEATING, COOLING AND VENTILATING AND LIGHTING (NOT APPLICABLE)**

---

- A. Provide temporary heat during construction for interior areas included in the Contract to counteract low temperatures or excessive dampness and, in any event, between October 15th and April 15th. Maintain during said period or periods until final completion of the Contract, unless otherwise approved by the Owner in writing. Windows, doors, ventilators and similar openings shall be temporarily closed. Provide heat and ventilation to maintain specified conditions for construction operations and to protect materials and finishes from damage by temperature or humidity. The permanent heating system is not to be used for temporary heating unless approved, in writing, by the Owner. The Contractor shall pay costs. See individual Sections for temperature/humidity limits. Temporary H methods shall comply with OSHA regulations and other applicable codes, statutes, rules and regulations and shall be approved by the Department of Public Works.
- B. Permanent air handling equipment, when used for temporary heating, shall be equipped with disposable "construction" filters. The construction filters shall have an average efficiency at least equal to the filters specified under Division 15, but not less than 30% when tested in accordance with ASHRAE 52-76. The filters shall have an average arrestance of not less than 90% efficiency on one (1) micron size particles. Before turning over the system for final acceptance, the contractor shall remove and dispose of the construction filters; spray clean the heating and cooling coils, and drain pans to "like new" condition; and install the filters specified in Division 15.
- A. The General Contractor may use the existing heating system with temporary extensions, radiators or unit heaters, but such use is subject to the Owner's approval. Coordinate use of existing facilities with Owner. Provide additional, temporary extensions and units to satisfy the criteria given in the preceding paragraph. Owner will pay cost of energy used. Take measures to conserve energy. At the termination of construction, return the facilities to their original condition. Before operation of permanent facilities, verify that installation is approved for operation and that filters are in place.
- A. Steam from the Agency's lines shall be metered and paid for by the Contractor at a price approved by the Agency. The Contractor shall arrange with his Heating Subcontractor to install and maintain temporary piping, radiators, or unit heaters, reducing valves, steam traps and other necessary fittings and accessories. Traps shall be provided to prevent steam from entering main returns. The temporary layout shall meet the approval of the Architect/Engineer. Condensate meter (or meters) shall be installed to record usage of steam. (The following sentence shall be used when steam is supplied free: "Steam from the Agency's lines will be furnished to the Contractor without cost, but may be discontinued if use is unreasonable or wasteful".) At the termination of construction, return the facilities to their original condition.

---

**01515 TEMPORARY TELEPHONE (NOT APPLICABLE)**

---

- A. General Contractor shall provide telephone service in his office. It is preferred the Contractor use a cellular phone. Local calls will be paid by the Contractor and toll calls by the respective users.

---

**01520 TEMPORARY WATER (NOT APPLICABLE)**

---

- A. Water for construction purposes may be taken from the existing service. The Contractor shall provide connections, approved backflow prevention device, meter and pipe to the water main or nearest hydrant, subject to the approval of the Owner. Upon completion of work, the Contractor shall remove the temporary connections and backfill if necessary. If new water service is installed before construction is complete, the new system may be used provided it is returned to the Owner in as-new condition. The Contractor shall pay for the water used, as metered.
- B. Water is not available on site. Transport water to the project. Cost shall be paid by the General Contractor.
- C. Connect to existing facilities, through an approved backflow prevention device; extend branch piping with outlets so that water is available by use of hoses. Owner will pay for water used. The Contractor shall not waste water or use faulty equipment. The Contractor shall provide, at his own expense, all connections, extensions and other apparatus required for use of such services. Upon completion of the Contract, the Contractor shall disconnect temporary extensions and return utility to its original condition.

---

**01525 TEMPORARY SANITARY FACILITIES (NOT APPLICABLE)**

---

- A. The Contractor shall provide, where directed, chemical toilets with toilet tissue, plus wash basins with water, soap and paper towels. The Contractor shall maintain the facilities in a sanitary condition.
- B. If women are employed in the work, provide separate, designated facilities for them of the same kind. Provide an adequate number of each kind of facility for each gender.
- C. Designated existing toilets may be used during construction. It is the responsibility of the Contractor to maintain the facilities in a clean and sanitary condition and return them to their original condition after use. No loitering or smoking will be permitted in these areas.

---

**01530 FIRE PROTECTION**

---

- A. The Contractor, during construction, shall be responsible for loss or damage by fire to the work of the Contract until completion. Any fire used within the structure for working purposes shall be extinguished when not in use. No flammable material shall be stored in the structure in excess of amounts allowed by the authorities. No gasoline shall be stored in or close to the building at any time. The Contractor shall assign a responsible employee to be in charge of fire protection measures.

---

**01535 CONSTRUCTION EQUIPMENT**

---

- A. The Contractor shall furnish tools, apparatus and appliances, hoists and/or cranes and power for same, scaffolding, runways, ladders, temporary supports and bracing and similar work or material necessary to insure convenience and safety in the execution of the Contract except where this is otherwise specified in any Specification Section. All such items shall meet the approval of the Owner but responsibility for design, strength and safety shall remain with the Contractor. All such items shall comply with Federal OSHA regulations and applicable codes, statutes, rules and regulations, including compliance with the requirements of the current edition of the "Manual of Accident Prevention in Construction" published by the A.G.C. and the standards of the State Labor Department.
- B. Staging, exterior and interior, required for the execution of this Contract, shall be furnished, erected, relocated if necessary and removed by the General Contractor. Staging shall be maintained in a safe condition without charge to and for the use of all trades as needed.

---

**01540 BARRIERS AND ENCLOSURES**

---

- A. Provide barriers to prevent public entry into construction areas and to protect existing facilities from damage by construction operations.

- B. Provide a fence around construction site; equip with vehicular and pedestrian gates with locks.
- C. Provide covered walkways as required by governing authorities for public rights-of-way and for public access to existing buildings.
- D. Provide barriers around trees and plants designated to remain. Protect against vehicular traffic, materials' dumping, chemically injurious materials, puddling or running water.
- E. Provide temporary, insulated, weathertight closures at openings to the exterior to provide acceptable working conditions and protection for materials, to allow for temporary heating and to prevent entry of unauthorized persons. Provide doors with self-closing hardware and locks.
- F. Barriers and enclosures shall be in conformance with code requirements. Do not block egress from occupied buildings unless necessary to further the work of the Contract. In this case, secure the Department's approval of an alternate egress plan.
- G. See also General Conditions Article 19.

---

**01545 PROTECTION**

---

- A. Protect buildings, equipment, furnishings, grounds and plantings from damage. Any damage shall be repaired or otherwise made good at no expense to the State.
- B. Provide protective coverings and barricades to prevent damage. The Contractor shall be held responsible for, and must make good at his own expense, any water or other type of damage due to improper coverings. Protect the public and building personnel from injury.
- C. Provide temporary protection for installed products. Control traffic in immediate area to minimize damage.
- D. Provide protective coverings for walls, projections, jambs, sills and soffits of openings. Protect finished floors and stairs from traffic, movement of heavy objects and storage. Prohibit traffic and storage on waterproofed and roofed surfaces and on lawn and landscaped areas.
- E. Provide temporary partitions and ceilings to separate work areas from Owner-occupied areas to prevent penetration of dust and moisture into Owner-occupied areas and equipment. Erect framing and sheet materials with closed joints and sealed edges at intersections with existing surfaces.
- F. See also General Conditions Article 19.

---

**01550 SECURITY**

---

- A. Provide security program and facilities to protect work, existing facilities and Owner's operations from unauthorized entry, vandalism and theft. Coordinate with Owner's security program.
- B. The Contractor shall be solely responsible for damage, loss or liability due to theft or vandalism.

---

**01555 TRAFFIC WAYS**

---

- A. The Contractor may use on-site paved roads and parking areas but shall not encumber same or their access. Public highways shall not be blocked by standing trucks, parked cars, material storage, construction operations or in any other manner.
- B. Public roads and existing paved roads, drives and parking areas on Owner's property shall be kept free from scrap or debris due to construction operations and any damage to their surface caused by the Contractor shall be repaired by him at his own expense.
- C. If the work of the Contract affects public use of any street, road, highway or thoroughfare, the G. C. shall confer with the police authority having jurisdiction to determine if and how many police are needed for public safety in addition to any barriers and signals that may be needed. The G.C. will be responsible for payment of any needed police services.

---

**01560 TEMPORARY CONTROLS**

---

- A. **Temporary Environmental Controls:** Contractor is to provide the following controls.

1. Rodent and Pest Control: Before deep foundation work has been completed, retain a local exterminator or pest control company to recommend practices to minimize attraction and harboring of rodents, roaches, and other pests. Employ this service to perform extermination and control procedures at regular intervals so the Project will be free of pests and their residues at materials.
2. *Dust Control (construction and demolition).*
3. *Noise Control, Pest Control.*
4. *Erosion and Sediment Control.*
5. *Pollution Control.*
6. *Traffic Control.*

---

**01565 STORM WATER CONTROL (NOT APPLICABLE)**

---

- A. Assume responsibility for Storm Water pollution control by submitting to the Connecticut Department of Energy and Environmental Protection (DEEP) a "General Permit for the Discharge of Storm Water and Dewatering Wastewaters from Construction Activities" registration; conform to the permit requirements.
- B. Conform to the Storm Water Pollution Control Plan included in the Contract Documents or have another plan, prepared at the General Contractor's expense, which has been approved by the Owner and Environmental Protection.
- C. The "General Permit for the Discharge of Storm Water and Dewatering Wastewater from Construction Activities" "draft" registration is attached to the technical Section 0227\_\_\_Storm Water Pollution Control.
- D. Sign, and cause to be signed by each appropriate subcontractor, the Certification Statement required by the General Permit.
- E. Provide, maintain, and monitor a rain gauge on the site; monitoring shall include maintaining a log of the readings. The rain gauge shall remain the property of the General Contractor.

---

**01570 CLEANING**

---

- A. Maintain areas under Contractor's control free of waste materials, debris and rubbish. Maintain in a clean and orderly condition.
- B. Remove debris and rubbish from pipe chases, plenums, attics, crawl spaces and other closed or remote spaces before closing the space.
- C. Periodically clean interior areas before start of surface finishing and continue cleaning on an as-needed basis.
- D. Control cleaning operations so that dust and other particulates will not adhere to wet or newly-coated surfaces.
- E. Remove waste materials, debris and rubbish from site daily and dispose of legally off-site. No scrap/debris shall remain inside the building or anywhere on site upon final acceptance of the project.
- F. See also General Conditions Article 24.

---

**01575 PROJECT SIGNS (NOT APPLICABLE)**

---

- A. Project Signs: Engage an experienced sign painter to apply graphics. Comply with details to be furnished by the Construction Administrator.
  1. Project Sign: The Contractor shall contact the Construction Administrator for the proper wording for the project sign. Fabricate sign of 3/4", exterior grade, A-B Fir plywood. Mount sign on preservative treated Fir posts. The Owner shall provide design, color selection and illustration of the Project Sign. Paint both sides and all edges of sign and the posts with two coats of exterior, white, alkyd primer. Paint the border and letters with "bulletin" (sign) paint. Letter sizes, colors and related information is given on the illustration from the Owner. A self-adhesive decal of the State seal will be furnished at the Contract signing. Erect the sign within two weeks after execution of the Contract and remove the sign within one week after completion of the project.
  2. The contractor shall contact the Construction Administrator for the proper wording for the project sign.

---

**01580 FIELD OFFICES AND SHEDS (NOT APPLICABLE)**

---

**A. Field Offices:**

1. The Contractor shall provide an office for his own use which may be a trailer type facility with electric lighting, air conditioning, and heat. It shall have ample natural light, a table, chairs, counter, shelf, plan racks and file cabinets. Provide a 5 lb. ABC fire extinguisher and an OSHA-approved first aid kit. If the contract amount is \$2,500,000 or more, the Contractor shall provide a facsimile machine in his office and shall also provide his superintendent with a message beeper.
2. The Contractor shall provide a field office for the Construction Administrator of not less than 150 sq. ft. which may be a trailer type facility. The field office shall have ample natural light, a heater of sufficient capacity to maintain 70 degrees (F) in winter and an air conditioner of sufficient capacity to maintain 75 degrees (F) in summer. The Contractor shall provide a 5-lb. ABC fire extinguisher, and an OSHA-approved first aid kit. The contractor shall furnish the following furniture, which will remain his property. Furniture may be used but shall be in good condition, as judged by the Construction Administrator.
  - a. (1) one two pedestal desk
  - b. (1) One plan table.
  - c. (1) One plan rack.
  - d. (5) Five chairs.
  - e. (2) Two file cabinets (lockable four drawer letter size).
  - f. (2) Two bookshelves w/10 L.F. of 12" wide shelving.
  - g. (2) Two large capacity waste receptacles.
  - h. (1) One Fax Machine with telephone line.
  - i. (1) One telephone with telephone line.
  - J. (1) One Answering Machine with telephone line.
  - k. (1) One Computer having PC with telephone line and E-mail connection capabilities: 200 MHz, (minimum) Pentium II with operating software, including but not limited to, Windows 95, AutoCAD (latest version), Microsoft Office 97, Microsoft Project (latest version) File Maker.
  - l. (1) One Laser printer with supplies.
  - m. (1) One Copy Machine with supplies.
2. The Agency will furnish, without charge, one room for the Contractor's use and one room for the Construction Administrator's use as an office in an existing building. The Contractor shall be responsible for furniture and shall keep these areas clean and return them to their original condition after use. The Contractor shall provide and install a 5-lb. ABC fire extinguisher and an approved first aid kit in both rooms.

**B. Storage and Fabrication Sheds:** Install storage and fabrication sheds sized, furnished, and equipped to accommodate materials and equipment involved, including temporary utility service. Sheds may be open shelters or fully enclosed spaces within the building or elsewhere on-site.

1. Storage sheds for tools, materials and equipment shall be weathertight with heat, lighting and ventilation for products requiring controlled conditions.
2. Remove temporary materials, equipment services and construction before Substantial Completion.
3. Clean and repair damage caused by installation or use of temporary facilities. Restore existing facilities used during construction to specified or to original condition.

---

**01585 IDENTIFICATION BADGES (NOT APPLICABLE)**

---

**A. Identification Badges for Contractor's Personnel, Visitors & Parking Stickers:**

1. The Contractor will provide each person working or visiting at the site with an identification badge, bearing the name of the Contractor and a number. As badges are assigns, a record shall be kept by the

- Contractor and given to the Construction Administrator and Agency Administrator. Update and correct the records of all badges issued on a semi-monthly basis.
2. Badges are to be worn on outer garment where visible at all times while at the construction site, return them to the Contractor's field office at the end of each day and pick them up there each morning.
  3. All vehicles parking in the Contractor's parking lot and those used around the site require an ID sticker. They will be issued by the Agency. Each contractor shall apply for parking stickers through the Construction Administrator no more than semi-monthly and shall keep record of all stickers issued.

---

**01600 MATERIALS AND EQUIPMENT CONTROLS**

---

- A. Materials and Equipment:** Shall be delivered, stored and handled to prevent intrusion of foreign matter and damage by weather or breakage. Packaged materials shall be delivered and stored in original, unbroken packages.
1. Promptly inspect shipments to assure that products comply with requirements, that quantities are correct and products are undamaged.
  2. Packages, materials and equipment showing evidence of damage will be rejected and replaced at no additional cost to the Owner.
- B. Storage and Protection:**
1. Store products in accordance with manufacturers' instructions with seals and labels intact and legible. Store sensitive products in weathertight enclosures; maintain within temperature and humidity range required by manufacturer.
  2. For exterior storage of fabricated products, place on sloped supports above ground. Cover products subject to deterioration with impervious sheet covering; provide ventilation to avoid condensation.
  3. Store loose granular material on solid surfaces in a well-drained area; prevent mixing with foreign matter.
  4. Arrange storage to provide access for inspection. Periodically inspect to insure products are undamaged and are maintained under required conditions. Keep log showing date, time and problems, if any.
  5. Stone, masonry units and similar materials shall be stored on platforms or dry skids and shall be adequately covered and protected against damage.
  6. The Contractor shall prepare, as directed by the Owner, one area or space in the building for storage of State-owned equipment.

---

**01631 EQUALS AND SUBSTITUTIONS**

---

- A. Definitions:** Definitions in this Article do not change or modify the meaning of other terms used in the Contract Documents.
1. Equals or Substitutions General: Changes in products, materials, equipment, and methods of construction required by the Contract Documents proposed by the Contractor after award of the Contract.
  2. Equal: Any deviation from the specification which is defined as follows: A replacement for the specified material, device, procedure, equipment, etc., which is recognized and accepted as substantially equal to the first listed manufacturer or first listed procedure specified, after review, by the Architect and may be rejected or approved at the sole discretion of the owner. All equals must be substantially equivalent to the first manufacturer or first procedure listed in the Specifications with reference to all of the following areas: the substance and function considering quality, workmanship, economy of operation, durability and suitability for purposes intended; size, rating and cost. The equal does not constitute a modification in the scope of Work, the Schedule or Architect/Engineer's design intent of the specified material, device, procedure, equipment, etc.
  3. Substitution: Any deviation from the specified requirements, which is defined as follows: A replacement for the specified material, device, procedure, equipment, etc., which is not recognized or accepted as equal to the first manufacturer or procedure listed in the Specification after review by the Architect and may be rejected or approved by the Owner. The Substitution is not equal to the specified requirement in comparison to the first manufacture or first procedure listed in the Specifications in one or more of the following areas: the substance and function considering quality, workmanship, economy of operation,

durability and suitability for purposes intended; size; cost and rating. The Substitution constitutes a modification in the scope of Work, the Schedule or the Architect/Engineer's design intent of the specified material, device, procedure, equipment, etc.

4. The following are not considered to be requests for Equals or Substitutions:
  - a. Revisions to the Contract Documents requested by the Owner or Architect.
  - b. Specified options of products and construction methods included in the Contract Documents.
  - c. The Contractor's determination of and compliance with governing regulations and orders issued by governing authorities having jurisdiction.

**B. Submittals:**

1. Equals and Substitution Request Submittals: The Owner will consider requests for equals or substitutions if received within time period designated in the General Conditions Article 15. Requests received more than the days specified in Article 15 after the start date of the contract will be rejected.
  - a. The Contractor is required to prepare and submit 3 copies of the required data for the first manufacturer listed or procedure listed in the specifications section with reference to all of the following areas: the substance and function considering quality, workmanship, economy of operation, durability and suitability for purposes intended including the size, rating and cost. All submissions must include all the required data for the first listed manufacturer or procedure as specified, as well as the required data for the proposed Equal or Substitution. This will enable the Owner and Architect to determine that the proposed Equal or Substitution is or is not substantially equal to the first listed manufacturer or procedure.
2. Identify the product or the fabrication or installation method to be replaced in each request. Include related Specification Section and Drawing numbers.
3. Provide complete documentation showing compliance with the requirements for equals or substitutions, and the following information, as appropriate on a "Substitution Request" form as required by the Owner:
  - a. Coordination information, including a list of changes or modifications needed to other parts of the Work and to construction performed by the Owner and separate contractors that will be necessary to accommodate the proposed Equal or Substitution.
  - b. A detailed comparison chart of significant qualities of the proposed substitution with those of the Work specified. Significant qualities may include elements, such as performance, weight, size, durability, and visual effect.
  - c. Product Data, including Shop Drawings and descriptions of products and fabrication and installation procedures.
  - d. Samples, where applicable or requested.
  - e. A statement indicating the effect on the Contractor's Construction Schedule or CPM Schedule compared to the schedule without approval of the Equal or Substitution. Indicate the effect on overall Contract Time.
  - f. Cost information, broken down, including a proposal of the net change, if any in the Contract Sum.
  - g. The Contractor's certification that the proposed Equal or Substitution conforms to requirements in the Contract Documents in every respect and is appropriate for the applications indicated.
  - h. The Contractor's waiver of rights to additional payment or time that may subsequently become necessary because of the failure of the Equal or Substitution to perform adequately.
4. Architect's Action: If necessary, the Architect will request additional information or documentation for evaluation within one week of receipt of the original request for equal or substitution request. The Architect will notify the Construction Administrator who will notify the Owner of recommended acceptance or rejection of the proposed equal or substitution, within two (2) weeks of receipt of the request, or one (1) week of receipt of additional information or documentation, whichever is later. The Construction Administrator will give final acceptance or rejection by the Owner not less than one (1) week after notification.

- a. Any request deemed an "Equal" and accepted by the Construction Administrator, Architect, Owner, and Agency will result in written notification to the Contractor and will not be in the form of a change order for an "Equal".
- b. Any request deemed a "Substitution" and rejected or approved by Construction Administrator, Architect, and Owner may result in written notification to the Contractor and may be in the form of a change order if the "Substitution" is approved.

**C. Equal or Substitutions:**

1. Conditions: The Architect will consider the Contractor's request for Equal or Substitution of a product or method of construction when one or more of the following conditions are satisfied, as determined by the Architect. If the following conditions are not satisfied, the Architect will return the requests to the Construction Administrator without action except to record noncompliance with these requirements.
  - a. The proposed request does not require extensive revisions to the Contract Documents.
  - b. The proposed request is in accordance with the general intent of the Contract Documents.
  - c. The proposed request is timely, fully documented, and/or properly submitted.
  - d. The proposed request can be provided within the Contract Time. However, the Architect will not consider the proposed request if it is a result of the Contractor's failure to pursue the Work promptly or coordinate activities properly.
  - e. The proposed request will offer the Owner a substantial advantage, in cost, time, energy conservation, or other considerations, after deducting additional responsibilities the Owner must assume. However, if the proposed request requires the Owner to incur additional responsibilities, including but not limited to, additional compensation to the Architect for redesign and evaluation services, increased cost of other construction by the Owner or similar considerations, then the Owner will have just cause to reject the request for Equal or Substitution.
  - f. The proposed request can receive the necessary approvals, in a timely manner, required by governing authorities having jurisdiction.
  - g. The proposed request can be provided in a manner that is compatible with the Work as certified by the Contractor.
  - h. The proposed request can be coordinated with the Work as certified by the Contractor.
  - i. The proposed request can uphold the warranties required by the Contract Documents as certified by the Contractor.
2. The Contractor's submission and the Architect's review of Submittals, including but not limited to, Samples, Manufacturer's Data, Shop Drawings, or other such items, which are not clearly identified as a request for an Equal or Substitution, will not be considered or accepted as a valid request for an Equal or Substitution, nor does it constitute an approval.

---

**01650 STARTING OF SYSTEM**

---

**A. General:**

1. Coordinate schedule for start-up of various equipment and systems.
2. Provide written notification the Construction Administrator thirty (30) Calendar Days prior to start-up of each item.
3. Verify that each piece of equipment or system has been checked for proper lubrication, drive rotation, belt tension, and control sequence for other conditions that may cause damage.
4. Verify that tests, meter readings, and specified electrical characteristics agree with those required by the equipment or system manufacturer.
5. Verify in wiring and support components are complete and tested.
6. Execute the start-up under supervision of manufacturer's representative, in accordance with manufacturer's instructions.

7. When referenced in individual specification sections, require manufacturer to provide an authorized representative to be present at the site to inspect, check, and approve equipment or system installation prior to start-up, and to supervise placing equipment or system in operation.
8. Submit a written report in accordance Section 01400 "Quality Control" that the equipment or system has been properly installed and is functioning properly.

**B. Demonstration and Instructions:**

1. Demonstrate operation and maintenance of Products to Owner and Agency Personnel two (2) weeks prior to substantial completion.
2. Demonstrate Project equipment and instruct in a classroom environment at location designated by the Construction Administrator and instructed by a qualified manufacturer's representative who is knowledgeable about the project.
3. For equipment or systems requiring seasonal operation perform demonstration for season within six (6) months.
4. Utilize operation and maintenance manuals as basis for instruction. Review contents of manual with Owner and Agency Personnel in detail to explain all aspects of operation and maintenance.
5. Demonstrate start-up, operation, control, adjustment, troubleshooting, servicing, and maintenance, and shutdown of each item at agreed upon scheduled time and at equipment or designated location.
6. Prepare and insert additional data in operations and maintenance manuals when need for additional data becomes apparent during demonstration.

**C. Testing Adjusting, and Balancing:**

1. The Contractor will employ and pay for the testing services of an independent consultant to verify the testing, adjusting, and balancing.
2. Reports will be submitted by the independent testing consultant to the Construction Administrator indicating observations and results of tests and indicating compliance or non-compliance with the requirements of the Contract Documents.
3. The Owner may employ and pay for the services of an independent consultant to verify testing, adjusting, and balancing which was performed by the Contractor.

---

**01700 CONTRACT CLOSEOUT**

---

**A. Substantial Completion:**

1. Preliminary Procedures: Before requesting inspection for Certification of Substantial Completion, complete the following. List exceptions in the request.
  - a. In the Application for Payment that coincides with, or first follows, the date Substantial Completion is claimed, show 100 percent completion for the portion of the Work claimed as substantially complete.
    - i. Include supporting documentation for completion as indicated in these Contract Documents and a statement showing an accounting of changes to the Contract Sum.
    - ii. If 100 percent completion cannot be shown, include a list of incomplete items, the value of incomplete construction, and reasons the Work is not complete.
  - b. Advise the Owner of pending insurance changeover requirements.
  - c. Submit specific warranties, workmanship bonds, maintenance agreements, final certifications, and similar documents.
  - d. Obtain and submit releases enabling the Owner unrestricted use of the Work and access to services and utilities. Include occupancy permits, operating certificates, and similar releases.
  - e. Submit record drawings, maintenance manuals, damage or settlement surveys, property surveys, and similar final record information.
  - f. Deliver tools, spare parts, extra stock, and similar items.

- g. Make final changeover of permanent locks and transmit keys to the Owner. Advise the Owner's personnel of changeover in security provisions.
  - h. Demonstration, thru operation and testing, the functions of all systems and/or equipment to the satisfaction of the Owner for compliance to the contract. Complete testing of systems, and instruction of the Owner's operation and maintenance personnel. Discontinue and remove temporary facilities from the site, along with mockups, construction tools, and similar elements.
  - i. Complete final cleanup requirements, including touchup painting.
  - j. Touch up and otherwise repair and restore marred, exposed finishes.
2. Inspection Procedures: The Contract shall be ready and prepared when they request a Substantial Completion inspection. If the inspection reveals that the work is not complete, there are extensive punchlist items and as the items listed above are not complete, the Construction Administrator, Architect, and Owner will determine the inspection has failed.
3. The Contractor is responsible for all costs to re-inspect due to a failed inspection. The Owner will issue a deduct change order to cover all costs for re-inspection.
- a. The Architect will repeat inspection when requested and assured that the Work is substantially complete.
  - b. Results of the completed inspection will form the basis of requirements for final acceptance.

**B. Final Acceptance:**

1. Preliminary Procedures: Before requesting final inspection for certification of final acceptance and final payment, complete the following. List exceptions in the request.
- a. Submit the final payment request with releases and supporting documentation not previously submitted and accepted. Include insurance certificates for products and completed operations where required.
  - b. Submit an updated final statement, accounting for final additional changes to the Contract Sum.
  - c. Submit a certified copy of the Architect's final inspection list of items to be completed or corrected, endorsed and dated by the Architect. The certified copy of the list shall state that each item has been completed or otherwise resolved for acceptance and shall be endorsed and dated by the Architect.
  - d. Submit final meter readings for utilities, a measured record of stored fuel, and similar data as of the date of Substantial Completion or when the Owner took possession of and assumed responsibility for corresponding elements of the Work.
  - e. Submit consent of surety to Final Payment.
  - f. Submit evidence of final, continuing insurance coverage complying with insurance requirements.
2. Reinspection Procedure: The Inspection Group will re-inspect the Work upon receipt of notice from the Construction Administrator that the Work, including inspection list items from earlier inspections, has been completed, except for items whose completion is delayed under circumstances acceptable to the Owner.
- a. Upon completion of reinspection, the Construction Administrator will prepare a certificate of final acceptance. If the Work is incomplete, the Construction Administrator will advise the Contractor of Work that is incomplete or of obligations that have not been fulfilled but are required for final acceptance.

**C. Record Document Submittals:**

1. **General:** Do not use record documents for construction purposes. Protect Record Documents from deterioration and loss in a secure, fire-resistant location. Provide access to record documents for the Architect's reference during normal working hours. Keep documents current; do not permanently conceal any work until required information has been recorded. Failure to keep documents current is sufficient cause to withhold progress payments.
- a. The Contractor shall also hire the services of a Surveyor registered in the State of Connecticut to conduct a final survey to determine the location of exterior underground utility lines and to record the results, and update existing electronic media

- b. The record of exterior underground utilities shall be made at the time of installation on Mylar film drawing and AutoCAD (latest version) compatible disks. The drawing shall bear the seal of the Land Surveyor and a statement of accuracy.
- 2. Record Drawings:** The Contractor shall maintain one clean, complete undamaged set of blue or black line white-prints of Contract Drawings and Shop Drawings. Mark the set to show the actual installation where the installation varies substantially from the Work as originally shown. Mark which drawing is most capable of showing conditions fully and accurately. Where Shop Drawings are used, record a cross-reference at the corresponding location on the Contract Drawings. Give particular attention to concealed elements that would be difficult to measure and record at a later date.
  - a. Mark record sets with erasable pencil to distinguish between variations in separate categories of the Work.
  - b. Mark all new information that is not shown on Contract Drawings.
  - c. Note related change-order numbers where applicable.
  - d. Organize record drawing sheets into manageable sets. Bind sets with durable-paper cover sheets; print suitable titles, dates, and other identification on the cover of each set.
  - e. Upon completion of the work, the Contractor shall submit Record Drawings to the Construction Administrator for the Owner's Records who will pass them on to the Architect or Engineer for transferring the changes to the Record Drawing Mylar Tracings.
  - g. Submit electronic format data of all revised drawings on CD-ROM format and in AutoCAD (latest version) compatible format.
- 3. Record Specifications:** The Contractor shall maintain one complete copy of the Project Manual, including Addenda. Include with the Project Manual one copy of other written construction documents, such as Change Orders and modifications issued in printed form during construction.
  - a. Mark these documents to show substantial variations in actual Work performed in comparison with the text of the Specifications and modifications.
  - b. Give particular attention to equals and substitutions and selection of options and information on concealed construction that cannot otherwise be readily discerned later by direct observation.
  - c. Note related record drawing information and Product Data.
  - d. Upon completion of the Work, submit record Specifications to the Construction Administrator for the Owner's records.
- 4. Record Product Data:** The Contractor shall maintain one copy of each Product Data submittal. Note related Change Orders and markup of record drawings and Specifications.
  - a. Mark these documents to show significant variations in actual Work performed in comparison with information submitted. Include variations in products delivered to the site and from the manufacturer's installation instructions and recommendations.
  - b. Give particular attention to concealed products and portions of the Work that cannot otherwise be readily discerned later by direct observation.
  - c. Upon completion of markup, submit complete set of Record Product Data to the Construction Administrator for the Owner's records.
- 5. Record Sample Submitted:** Immediately prior to Substantial Completion, the Contractor shall meet with the Construction Administrator, Architect and the Owner's personnel at the Project Site to determine which Samples are to be transmitted to the Owner for record purposes. Comply with the Owner's instructions regarding delivery to the Owner's Sample storage area.
- 6. Miscellaneous Record Submittals:** Refer to other Specification Sections for requirements of miscellaneous record keeping and submittals in connection with actual performance of the Work. Immediately prior to the date or dates of Substantial Completion, complete miscellaneous records and place in good order. Identify miscellaneous records properly and bind or file, ready for continued use and reference. Submit to the Construction Administrator for the Owner's records.

7. **Maintenance Manuals:** Organize operation and maintenance data into suitable sets of manageable size. Bind properly indexed data in individual, heavy-duty, 2-inch (51-mm), 3-ring, vinyl-covered binders, with pocket folders for folded sheet information. Mark appropriate identification on front and spine of each binder according to section 01730. Included but not limited to the following types of information:
- a. *Emergency instructions.*
  - b. *Spare parts list.*
  - c. *Copies of warranties.*
  - d. *Wiring diagrams.*
  - e. *Recommended "turn-around" cycles.*
  - f. *Inspection procedures.*
  - g. *Shop Drawings and Product Data.*
  - h. *Fixture lamping schedule.*

**D. Closeout Procedures:**

1. Operation and Maintenance Instructions: Arrange for each Installer of equipment that requires regular maintenance to meet with the Owner's personnel to provide instruction in proper operation and maintenance. Provide instruction by manufacturer's representatives if installers are not experienced in operation and maintenance procedures. Include a detailed review of the following items:
  - a. *Maintenance manuals.*
  - b. *Record documents.*
  - c. *Spare parts and materials.*
  - d. *Tools.*
  - e. *Lubricants.*
  - f. *Fuels.*
  - g. *Identification systems.*
  - h. *Control sequences.*
  - i. *Hazards.*
  - j. *Cleaning.*
  - k. *Warranties and bonds.*
  - l. *Maintenance agreements and similar continuing commitments.*
2. As part of instruction for operating equipment, demonstrate the following procedures:
  - a. Startup.
  - b. Shutdown.
  - c. Emergency operations.
  - d. Noise and vibration adjustments.
  - e. Safety procedures.
  - f. Economy and efficiency adjustments.
  - g. Effective energy utilization.

**E. Final Cleaning:**

1. **General:** The General Conditions requires general cleaning during construction. Regular site cleaning is included in Division 1 Section 01570 "Cleaning".
2. Employ experienced workers or professional cleaners for final cleaning. Clean each surface or unit to the condition expected in a normal, commercial building cleaning and maintenance program. Comply with manufacturer's instructions. Complete the following cleaning operations before requesting inspection for Certification of Substantial Completion and Certification of Occupancy.

**3. Interior:**

- a. Remove labels that are not permanent labels.
- b. Clean transparent materials, including mirrors and glass in doors and windows. Remove glazing compounds and other substances that are noticeable vision-obscuring materials. Replace chipped or broken glass and other damaged transparent materials. Remove paint spots; wash and polish glass
- c. Clean exposed interior hard-surfaced finishes to a dust-free condition, free of stains, films, and similar foreign substances. Restore reflective surfaces to their original condition. Leave concrete floors broom clean. Vacuum carpeted surfaces.
- d. Wash washable surfaces of mechanical, electrical equipment and fixtures and replace filters, clean strainers on mechanical equipment. Remove excess lubrication and other substances. Clean plumbing fixtures to a sanitary condition. Clean light fixtures and lamps.
- e. Clean and polish finish hardware.
- f. Clean and polish tile and other glazed surfaces.
- g. Clean floors; wax and buff resilient tile. Clean vinyl or rubber base.
- h. Vacuum and/or dust walls, ceilings, lighting fixtures, ceiling diffusers and other wall and ceiling items.
- i. Remove defacements, streaks, fingerprints and erection marks.

**4. Exterior:**

- a. Clean the site, including landscape development areas, of rubbish, litter, and other foreign substances. Sweep paved areas broom clean; remove stains, spills, and other foreign deposits. Rake grounds that are neither paved nor planted, to a smooth, even-textured surface.
- b. Clean exposed exterior hard-surfaced finishes to a dust-free condition, free of stains, films, and similar foreign substances
- c. Clean roofs, gutters and downspouts.
- d. Remove waste and surplus materials, rubbish and construction equipment and facilities from the site, and deposit it legally elsewhere.
- e. Clean transparent materials, including mirrors and glass in doors and windows. Remove glazing compounds and other substances that are noticeable vision-obscuring materials. Replace chipped or broken glass and other damaged transparent materials. Remove paint spots; wash and polish glass.

**5. Pest Control:** Engage an experienced, licensed exterminator to make a final inspection and rid the work of rodents, insects, and other pests.

**6. Removal of Protection:** Remove temporary protection and facilities installed for protection of the Work during construction.

**7. Compliance:** Comply with regulations of authorities having jurisdiction and safety standards for cleaning. Do not burn waste materials. Do not bury debris or excess materials on the Owner's property. Do not discharge volatile, harmful, or dangerous materials into drainage systems. Remove waste materials from the site and dispose of lawfully.

- a. Where extra materials of value remain after completion of associated Work, they become the Owner's property. Dispose of these materials as directed by the Construction Administrator.
- b. Leave building clean and ready for occupancy. If the Contractor fails to clean up, the Owner may do so, with the cost charged to the Contractor. The Owner will issue a credit change order to cover the costs.

---

**01730 OPERATION AND MAINTENANCE DATA**

---

- A. The Contractor shall instruct the State's designated personnel in the operation of new equipment and shall provide manuals and if required, provide video tapes of this basic maintenance of the equipment for training purposes. Provide qualified personnel for as long as necessary to instruct the State's personnel.
- B. Submit four copies of the manuals in 3-ring, loose-leaf notebooks to the Architect/Engineer for approval. Manuals may consist of plain paper copies of approved shop drawings and catalog cuts. Upon completion and approval, 3 copies will be forwarded to the State and one copy retained by the Architect/Engineer.
- C. Manuals shall include:
  - 1. Operating Procedures:
    - a. Typewritten procedures for each mode of operation of each piece of equipment. Procedures shall indicate the status of each component of a system in each operating mode.
    - b. Procedures shall include names, symbols, valve tags, circuit numbers, schematic wiring diagrams, locations of thermostats, manual starters, control cabinets and other controls of each system.
    - c. Emergency shut-down procedures for each piece of equipment or system, both automatic and manual, as appropriate.
  - 2. Maintenance Schedule:
    - a. Typewritten schedule describing manufacturers schedule of maintenance and maintenance procedures.
  - 3. Catalog Cuts:
    - a. To illustrate each piece of installed equipment, including options.
    - b. Include equipment descriptions including physical, electrical and mechanical; performance characteristics; installation or erection diagrams.
    - c. Include spare parts numbers and names, address and phone number of manufacturer; name, address and phone number of local representative or service department.
    - 4. Typewritten list of all subcontractors on the project, including name, address and phone number of local representative or service department.
- 4. Manuals shall be indexed with dividers indicating each system or piece of equipment.

---

**01740 WARRANTIES AND GUARANTEES**

---

- A. **Disclaimers and Limitations:** Manufacturer's disclaimers and limitations on product warranties do not relieve the Contractor of the warranty on the Work that incorporates the products. Manufacturer's disclaimers and limitations on product warranties do not relieve suppliers, manufacturers, and subcontractors required to countersign special warranties with the Contractor.
- C. **Related Damages and Losses:** When correcting failed or damaged warranted construction, remove and replace construction that has been damaged as a result of such failure or must be removed and replaced to provide access for correction of warranted construction.
- B. **Reinstatement of Warranty:** When Work covered by a warranty has failed and been corrected by replacement or rebuilding, reinstate the warranty by written endorsement. The reinstated warranty shall be equal to the original warranty with an equitable adjustment for depreciation.
- C. **Replacement Cost:** Upon determination that Work covered by a warranty has failed, replace or rebuild the Work to an acceptable condition complying with requirements of the Contract Documents. The Contractor is responsible for the cost of replacing or rebuilding defective Work regardless of whether the Owner has benefited from use of the Work through a portion of its anticipated useful service life.
- D. **Owner's Recourse:** Expressed warranties made to the Owner are in addition to implied warranties and shall not limit the duties, obligations, rights, and remedies otherwise available under the law. Expressed warranty periods shall not be interpreted as limitations on the time in which the Owner can enforce such other duties, obligations, rights, or remedies.

1. Rejection of Warranties: The Owner reserves the right to reject warranties and to limit selection to products with warranties not in conflict with requirements of the Contract Documents.
- E. Where the Contract Documents require a special warranty, or similar commitment on the Work or part of the Work, the Owner reserves the right to refuse to accept the Work, until the Contractor presents evidence that entities required to countersign such commitments are willing to do so.
- F. The Contractor shall guarantee all materials and workmanship for a period of eighteen months from the date of acceptance of the Work. In addition, the Contractor shall furnish the warranties listed below. Submit four copies of each to the Construction Administrator in the supplier's standard form or in the form given below if there is no standard form available.
- F. The Contractor shall guarantee all materials and workmanship for a period of eighteen months from the date of acceptance of the Work. In addition, the Contractor shall furnish the warranties listed below. Submit four copies of each to the Construction Administrator in the supplier's standard form or in the form given below if there is no standard form available.
- G. Submit certification that finish materials are fire rated as specified.
- H. Form of Guarantees and Warranties:

*Facilities Management & Planning  
83 Windham Street Willimantic, Connecticut 06226*

*Baseball, Softball, & Rugby, Field Renovation  
ECSU 2020-8*

*I (We) hereby guarantee and warranty)*

*the \_\_\_\_\_ work on the referenced project for a period of \_\_\_\_\_ years  
from \_\_\_\_\_, 2020 against failures of workmanship and materials in accordance  
with the requirements of Section \_\_\_\_, Page \_\_\_\_, Paragraph \_\_\_\_, of the Specifications.*

*Signed* \_\_\_\_\_

*General Contractor  
(or authorized agent)* \_\_\_\_\_

- I. Bonds shall be by approved Surety Companies, made out to the Director of Facilities Management & Planning, Eastern Connecticut State University on the Companies standard form.
- J. Guarantees, warranties or bonds supplied by Subcontractors, Suppliers or Manufacturers shall reference the project name, number, and location and be certified by the General Contractor to be for the product and installation on the project and must be countersigned by the General Contractor.

**G. Submittals:**

- 1. Submit written warranties prior to the date certified for Substantial Completion. If the Architect's Certificate of Substantial Completion designates a commencement date for warranties other than the date of Substantial Completion for the Work, or a designated portion of the Work, submit written warranties upon request of the Architect.
- 2. Forms for special warranties are included in this Section. Prepare a written document utilizing the appropriate form, ready for execution by the Contractor, or by the Contractor, subcontractor, supplier, or manufacturer. Submit a draft to the Owner, through the Construction Administrator, for approval prior to final execution.
  - a. Refer to Divisions 2 through 16 Sections for specific content requirements and particular requirements for submitting special warranties.
- 3. Form of Submittal: At Final Completion compile 2 copies of each required warranty properly executed by the Contractor, or by the Contractor, subcontractor, supplier, or manufacturer. Organize the warranty documents into an orderly sequence based on the table of contents of the Project Manual.
- 4. Bind warranties and bonds in heavy-duty, commercial-quality, durable 3-ring, vinyl-covered loose-leaf binders, thickness as necessary to accommodate contents, and sized to receive 8-1/2-by-11-inch (115-by-280-mm) paper.
  - a. Provide heavy paper dividers with celluloid covered tabs for each separate warranty. Mark the tab to identify the product or installation. Provide a typed description of the product or installation, including the name of the product, and the name, address, and telephone number of the Installer.
  - b. Identify each binder on the front and spine with the typed or printed title "WARRANTIES," Project title or name, and name of the Contractor.
  - c. When warranted construction requires operation and maintenance manuals, provide additional copies of each required warranty, as necessary, for inclusion in each required manual.

**END OF DIVISION 1- GENERAL REQUIREMENTS**

**Project No. ECSU 2020-8**

# TECHNICAL SPECIFICATIONS

## TABLE OF CONTENTS

<b>Section No.</b>	<b>Title</b>
02200	General Earthwork
02230	Site Preparation
02810	Irrigation
02910	Athletic Playing Fields
02920	Topsoil

**PART 1 - GENERAL**

**1.1 REQUIREMENTS, CODES**

- A. All applicable portions of Division 1 - General Requirements shall be considered as included with this section.
- B. The following are minimum requirements and shall govern except that all Federal, Local and/or State Codes and Ordinances shall govern when their requirements are in excess hereof.

**1.2 RELATED DOCUMENTS**

- A. The Contract Drawings indicate and show limits of construction for this project. These Specifications specify material and work requirements for this project. Both are complementary to each other, and both shall be followed to properly complete the work. Plans govern over technical specifications.

**1.3 GENERAL DESCRIPTION**

- A. For field areas: remove surface turf for fraise mowing, partial root zone mix for sod installation, infield mixes, excavation via trenching for irrigation adjustments, or otherwise unsuitable material from the proposed improvement area.
- B. Without limiting the generality thereof, furnish all labor and materials to complete earthwork within the limits of work as shown on the Contract Drawings and/or herein specified including, but not necessary limited to:
  - 1. Construction stakeout performed by the Contractor.
  - 2. Excavation and legal off-site disposal of excess soil materials.
  - 3. Fill and refill and finish grade preparation as indicated or required, using specified materials.
  - 4. Placement of bedding and backfilling of any trenches needed.
  - 5. Fine grading including compaction for existing materials, backfills and refills.
  - 6. Control of all groundwater and surface water for all work under this Contract.
  - 7. Dust, erosion, siltation and environmental controls.
  - 8. Removal and disposal of debris materials and surplus excavated soils.
- C. Related Work Described Elsewhere:
  - 1. Submittals Division 1 General Conditions
  - 2. Testing Laboratory Services General Conditions  
for Quality Control
  - 3. Site Preparation and Clearing Section 02230



8. Costs related to retesting due to failure shall be paid for by the Contractor at no additional expense to Owner. Owner reserves right to employ an independent testing laboratory and to direct testing that is deemed necessary. Contractor shall provide free access to site for testing activities.
  
- C. Costs for sampling, transporting and making all laboratory tests required to obtain characteristics of materials from on-site and off-site sources proposed to be used for fills, refills, surcharge fills and backfills including gradation tests and determination of moisture-density relationships, shall be borne by the Contractor.

## **1.5 SUBMITTALS**

- A. Test Reports: Submit in accordance with Division 1.
  1. At least one (1) gradation test and one plasticity test per ASTM D 4318 report for each type of fill for the infield mix. Report shall include name and location of sample tested.
  2. Compaction Curves per ASTM D-1557 for each type of soil material used.

The Owner will retain a consultant who will perform various tests and observations to determine if the suitability of the infield preparation area and subgrade. The testing consultant shall also verify that proper materials and construction methods are used, and that the Contractor is achieving the minimum amount of compaction as required by these specifications.

## **1.6 SITE INVESTIGATION**

- A. The Contractor acknowledges that he has satisfied himself as to the nature and location of the work, the general and local conditions, particularly those bearing upon transportation, disposal, handling and storage of materials, availability of labor, water, electric power, roads and uncertainties of weather, groundwater table or similar physical conditions at the site, the conformation of subsurface materials to be encountered, the character of equipment and facilities needed prior to and during the prosecution of the work and all other matters which can in any way affect the work or the cost thereof under this contract. Any failure by the Contractor to acquaint himself with all information concerning these conditions will not relieve him from responsibility for estimating properly the difficulty or cost of successfully performing the work.

## **1.7 PROTECTION OF EXISTING STRUCTURES**

- A. The Contractor shall protect existing underground utilities to remain, the location of which is shown approximately on the drawings or which are located in the fields. Utilities whose location is not known shall be protected insofar as possible. All costs for repair of broken or damaged utilities will be the responsibility of the Contractor.
  
- B. Visit the site to review all details of the work and working conditions and to verify dimensions in the field including headroom and interference's from adjacent structures. Notify the Owner in writing of any discrepancy before performing any work.

- C. Protect existing above ground structures and appurtenances from movement or settlement. Provide bracing and shoring as needed.
- D. Consult official records of existing utilities, both surface and subsurface, and their connections to be fully informed on all existing conditions and limitations as they apply to this work and its relation to other construction work. The Contractor shall contact Call before you Dig” at 1-800-922-4455 to assist in locating utilities at least 4 working days prior to performing any earthwork operations on the site.
- E. Make a personal inspection of the site to evaluate the conditions affecting the work. No claim for additional costs will be allowed because of lack of knowledge of any existing conditions discernible from observation of the site, adjoining properties, or other available sources of information.

### **1.8 APPLICABLE STANDARDS**

- A. ASTM D-422 - Method for sieve analysis of fine and coarse aggregates.
- B. ASTM D-1140 - Method for determination of fine soil fraction.
- C. ASTM D-1556 - Test method for density of soil and soil aggregate in place by the sand cone method.
- D. ASTM D-1557 - Test method for moisture - density relationships of soils and soil aggregate mixtures.
- E. ASTM D-2167 - Test method for density of soil and soil aggregate in place by the balloon method.
- F. ASTM D 4318 Test method for determination of Plasticity Index of soils.
- G. ASTM D-5195 - Test method for density of soil and rock at depths below the surface by nuclear methods.
- H. ASTM D-5220 - Test method for water content of soil and rock in-place by neutron depth probe method.

### **1.9 SITE PREPARATION**

- A. The Contractor shall verify existing grades prior to beginning general earthwork. If existing grades are at variance with the Drawings, notify the Owner and receive instructions prior to proceeding.
- B. All bench marks shall be protected during construction. If disturbed or destroyed, replace in original position.

## **PART 2 - PRODUCTS**

### **2.1 MATERIALS**

- A. Topsoil shall consist of suitable organic soil, free from ice and snow, clay, large stones, or debris conforming to the requirements of Division 2 of these specifications.
- B. Field specific materials are covered in Section 02910 - Athletic Playing Fields.

## **PART 3 EXECUTION**

### **3.1 EXAMINATION AND PREPARATION**

- A. Verify that survey benchmark and intended elevation for the work are as indicated.
- B. Identify required lines, levels, contours, and datum.
- C. Notify Owner in writing of unexpected subsurface conditions and discontinue affected work in area until notified to resume work.
- D. Identify and flag known utility locations. Maintain and protect existing utilities to remain and which pass through the work areas.
- E. No fill material from the site shall be reused. Contractor shall import new, tested, and approved material for the infield.

### **3.2 PROTECTION OF ADJACENT WORK**

- A. Protect all adjacent structures which may be damaged by excavation work, including service utilities and pipe chases. All damage caused by construction activities shall be repaired by the Contractor at no additional expense to the Owner.
- B. Grade excavations and fills to prevent surface water runoff into the work area or to adjacent wetlands.

### **3.3 EXCAVATION AND REMOVAL OF SOIL MATERIAL**

- A. Excavated sod, soil mixtures, and unsuitable materials shall be removed from the project at the Contractor's expense.

### **3.4 SITE EXCAVATION**

- A. All areas within the limits of work shall be excavated or filled with suitable material to the subgrade lines and elevations as shown on the plans and cross sections in accordance with these specifications

Surplus material shall be disposed of off-site in a legal manner at the Contractor's expense.

- B. Protect all subgrade soils.
- C. Maintain safe and stable excavation walls in accordance with OSHA requirements.
- D. Correct unauthorized excavation at no additional cost to the Owner.

### **3.5 TRENCH EXCAVATION**

- A. Excavate for irrigation system at locations indicated on the Drawings. Over excavate and remove unsuitable material and replace and compact with material approved by the Construction Administrator.
- B. Support pipe and conduit during placement and compaction of bedding fill.
- C. Protect and/or modify existing irrigation system.
- D. Backfill trenches with specified material according to the specifications contained herein and the Contract Drawings to required contours and elevations.
- E. Place and compact fill materials in accordance with specifications contained hereinafter.
- F. Dispose of unsuitable materials, rock not to be used, etc. in a legal manner offsite.

### **3.6 PROOFROLLING**

- A. Proofroll existing natural soil subgrade and fill subgrades within athletic field areas prior to placement of fill in all areas, in two perpendicular directions. Proofrolling shall be accomplished with a minimum of 6 passes of a vibratory steel drum roller with a minimum static weight of 30,000 pounds. This work shall be performed under the direct observation of the Construction Administrator.

### **3.7 PLACEMENT AND COMPACTION OF FILL**

- A. All areas within the limits of work shall be filled or excavated and filled with approved materials to the subgrade lines and elevations as shown on the plans as herein specified.
- B. The Construction Administrator must be allowed sufficient time to make necessary observations and tests. A minimum of four working days shall be required by the Construction Administrator for performing laboratory compaction and sieve tests.  
  
Forty-eight hours notice shall be given by the Contractor to the Construction Administrator when field observations and tests are required.
- C. Grade and compact fill surface to readily shed water. Slope fill surfaces away from buildings a minimum of two inches in 10 feet, unless otherwise noted. Make grade changes gradual. Blend slope into level areas.
- D. At completion of work, leave site completely free of excess fill materials.

- E. The degree of compaction shall be based on a maximum dry density as determined by ASTM D-1557. Compaction of silt and clays and of fine sand and silty sand shall be per materials at moisture contents within the percentages of acceptable optimum moisture contents. The degree of compaction for fill placed in various areas shall be as follows:

<u>Areas</u>	<u>Maximum Degree of Compaction</u>
1. Trench backfill	92%
2. General Landscaping Areas	90%

- F. After all excavation has been completed, unless indicating otherwise herein, all new fill materials shall be deposited in loose lift thickness not exceeding six (6) inches in depth over the areas to be filled.

The entire area of each layer shall be compacted with the specified equipment to the specified degree as outlined herein. No subsequent layer shall be deposited until the specified compaction is achieved for the previous layer. If necessary to obtain the required compaction due to fill becoming too dry, water shall be added if authorized by the Construction Administrator.

Compacted fills shall be prevented from freezing by use of approved admixtures or by use of approved protection on the surface, or both.

- G. Excavated material is unacceptable as fill within the proposed improvement area.

H. Procedures

1. Protect both fill and cut areas by grading surface topography to promote drainage away from these areas and by providing smooth surfaces which readily shed water.

To the extent that it is practicable, each layer of fill shall be compacted to the specified density the same day it is placed.

2. Fill that is too wet for proper compaction shall be diced, harrowed, or otherwise dried to a proper moisture content for compaction to the required density. If the fill material cannot be dried within forty-eight (48) hours of placement, it shall be removed and replaced with drier fill.

New fill shall have a moisture content which is within 5% of the optimum moisture content per ASTM D-1557 for Clay and Silt placed greater than 6 feet below pavement or embankment grades.

### **3.8 FILL PLACEMENT IN TRENCHES**

- A. As soon as practicable after the pipe has been placed and the pipe joints made in accordance with the appropriate Sections(s) of the Specification, and the pipe has been inspected and approved by the Construction Administrator, backfilling shall be performed. The Contractor shall be held

- responsible for the satisfactory execution of pipe line construction. If subsequent testing shows defects in materials or workmanship, the necessary repairs and replacements shall be made by the Contractor at his own expense to the satisfaction of the Construction Administrator
- B. Bedding shall be as specified for the particular type of pipe installation and as shown on the Drawings. Backfill shall be placed simultaneously on either side of the pipe alignment. In placing material, care shall be taken that stones do not strike the pipe.
  - C. Placement of bedding shall be done manually by persons skilled in this operation and shall precede the laying of pipe by no more than a few feet.
  - D. From the bottom of the pipe in the trench to a minimum of 6 inches above the pipe crown, the trench shall be backfilled by placing and packing the specified materials by hand shovel. The filling shall be carried up evenly on both sides of the pipe, care being taken not to raise or otherwise dislodge the pipe. Backfill to this depth shall be thoroughly compacted with approved hand-operated devices.
  - E. No stone or rock fragment greater than 1 inch shall be placed into the trench. Large masses of backfilling materials shall not be dropped into the tamped layers of backfill until at least one foot of backfill has been placed over the top of the pipe. Backfilling shall be placed in 12-inch maximum loose lifts.

### **3.9 GRADING AND ELEVATIONS**

- A. Base preparation shall be carefully shaped to the required cross section and constructed as follows:
  - 1. All grading, cuts and fills shall be controlled by conical laser guided earthwork machinery. Failure to use a conical laser setup shall be grounds for rejection of any and all of the grading required to construct the infield areas.
  - 2. Fill areas of subgrade where required in 6 inch lifts using laser guided equipment. Compact to 86% to 92%. Tolerance from elevation for prepared subgrade shall be  $\pm 1$  inch using a 10 foot straight edge upon completion. The Owner shall inspect subgrade elevations prior to placement of any other material. Correct subgrade grading per Owner's direction.
  - 3. Thoroughly water soak draining layer with water, a minimum of 2" of water over the entire surface to insure proper settlement. Fill in any low spots identified after watering.
  - 4. For installation of infield mix and sod, see Section 02910 Athletic Playing Fields.
  - 5. Fine grade to proper elevations. Tolerance from elevation for finished grade shall be  $+1/2$ in,  $-0$  inch using a 10 foot straight edge upon completion. Project Owner shall inspect subgrade elevations prior to placement of any other material. Correct subgrade grading per Owner's direction.
- B. Grading outside building lines shall consist of grading areas adjacent to building lines to drain away from structures and to prevent ponding. Finish ground surfaces shall be free from irregular surface changes, and meet the following requirements:
  - 1. Planted areas: Finished areas scheduled to receive topsoil to within not more than 2" above or below the required subgrade elevations.

2. Pavements: Shape surface areas under pavement to line, grade and cross-section, with finish surface not more than 1" above or below the required subgrade elevation.
- C. The Drawings indicate, in general, the alignment and finished grade elevations of site structures, the Owner's representative, however, may make such adjustments in grades and alignment as are found necessary in order to avoid interference and other special conditions encountered. Grading between indicated final grades shall provide smooth, even surfaces, except as otherwise required. Minimum cover over pipes shall, in any case, conform to requirements of local and state agencies having jurisdiction.

### **3.10 REMOVAL OF SURPLUS MATERIALS**

- A. Remove all surplus earth, boulders, and rock materials including unsuitable miscellaneous fill materials and debris, not needed to complete filling and grading to an approved area off-site and outside of the work limits. No on-site area shall be approved by the Owner. All surplus materials removed off-site and outside of the work limits shall become the property of the Contractor. Costs for transportation and disposal of surplus on-site and off-site materials shall be included in the Contractor's Lump Sum Bid Price.

### **3.11 FIELD QUALITY CONTROL**

- A. Testing and analysis of fill materials will be performed in accordance with ASTM D-422, D-1140 and D-1557.
- B. In-place compaction testing will be performed in accordance with ASTM D-1556, D-2167 or ASTM D-5195.
- C. If tests indicate work does not meet specified requirements, remove work or recompact where appropriate, replace and retest at no cost to Owner.

### **3.12 PROTECTION**

- A. Protect excavations to prevent cave-in or loose soil or debris from falling into excavation. Observe OSHA standards for trenching and excavation.

**END OF SECTION 02200**

## **PART 1 - GENERAL**

### **1.1 RELATED DOCUMENTS**

- A. Drawings and general provisions of the Contract, including General and Supplementary Conditions and Division 1 Specification Sections, apply to this Section.

### **1.2 SUMMARY**

- A. This Section includes the following:
  - 1. Protecting existing drainage pipe, irrigation system, and grass to remain.
  - 2. Regrading existing infield mix
  - 3. Irrigation head and swing joint removal and other adjustments / additions.
  - 4. Stripping and exporting turf plant material.
  - 5. Temporary erosion and sedimentation control measures.
- B. Related Sections include the following:
  - 1. Division 1 Section 01500 "Construction Facilities and Temporary Controls" for temporary utilities, temporary construction and support facilities, temporary security and protection facilities, and temporary erosion and sedimentation control procedures.
  - 2. Division 1 Section 01010 "Summary of Work" for verifying utility locations and for recording field measurements.
  - 3. Division 2 Section 02200 "Earthwork" for soil materials, excavating, backfilling, and site grading.
  - 4. Division 2 Section 02910 "Athletic Playing Fields" for finish grading including preparing and placing infield mixes and testing of soil material.
  - 5. Division 2 Section 02920 "Topsoil" for finish grading including preparing and placing topsoil and testing.

### **1.3 DEFINITIONS**

- A. Topsoil: Natural or cultivated surface-soil layer containing organic matter and sand, silt, and clay particles; friable, pervious, and black or a darker shade of brown, gray, or red than underlying subsoil; reasonably free of subsoil, clay lumps, gravel, and other objects more than 2 inches (50 mm) in diameter; and free of subsoil and weeds, roots, toxic materials, or other nonsoil materials.

### **1.4 MATERIAL OWNERSHIP**

- A. Except for stripped topsoil or other materials indicated to remain Owner's property, cleared materials shall become Contractor's property and shall be removed from Project site.

**1.5 SUBMITTALS**

- A. Photographs, sufficiently detailed, of existing conditions, adjoining construction, and site improvements that might be misconstrued as damage caused by site clearing.
- B. Record drawings, according to Division 1 Section "Project Record Documents," identifying and accurately locating capped utilities and other subsurface structural, electrical, and mechanical conditions.

**1.6 QUALITY ASSURANCE**

- A. Pre-installation Conference: Conduct conference at Project site to comply with requirements in Division 1 Section "Project Management and Coordination."

**1.7 PROJECT CONDITIONS**

- A. Traffic: Minimize interference with adjoining roads, streets, walks, and other adjacent occupied or used facilities during site-clearing operations.
  - 1. Do not close or obstruct streets, walks, or other adjacent occupied or used facilities without permission from Owner and authorities having jurisdiction.
  - 2. Provide alternate routes around closed or obstructed traffic ways if required by authorities having jurisdiction.
- B. Salvable Improvements: Carefully remove items indicated to be salvaged and store on Owner's premises where indicated.
- C. Utility Locator Service: Notify utility locator service for area where Project is located before site clearing.
- D. Do not commence site clearing operations until temporary erosion and sedimentation control measures are in place.

**PART 2 - PRODUCTS**

**2.1 SOIL MATERIALS**

- A. Satisfactory Soil Materials: Requirements for satisfactory soil materials are specified in Division 2 Section "Earthwork" and "Athletic Playing Fields".
  - 1. Obtain tested and approved soil materials off-site.

## **PART 3 - EXECUTION**

### **3.1 PREPARATION**

- A. Protect and maintain benchmarks and survey control points from disturbance during construction.
- B. Locate and clearly mark lawn to remain.
- C. Protect existing site improvements to remain from damage during construction.
  - 1. Restore damaged improvements to their original condition, as acceptable to Owner.

### **3.2 TEMPORARY EROSION AND SEDIMENTATION CONTROL**

- A. Provide temporary erosion and sedimentation control measures to prevent soil erosion and discharge of soil-bearing water runoff or airborne dust to adjacent properties and walkways, according to control drawings as indicated on the plans.
- B. Inspect, repair, and maintain erosion and sedimentation control measures during construction until permanent vegetation has been established.
- C. Remove erosion and sedimentation controls and restore and stabilize areas disturbed during removal.

### **3.3 UTILITIES / IRRIGATION SYSTEM**

- A. Locate, identify, disconnect, and seal or cap off irrigation systems as indicated to be modified.
- B. Existing Utilities: Do not interrupt utilities serving facilities occupied by Owner or others unless permitted under the following conditions and then only after arranging to provide temporary utility services according to requirements indicated:

### **3.4 CLEARING**

- A. Remove obstructions and turf to permit installation of new construction.
  - 1. Do not remove turf indicated to remain.
- B. Fill depressions caused by clearing operations with satisfactory soil material unless further excavation or earthwork is indicated.
  - 1. Place fill material in horizontal layers not exceeding a loose depth of 6 inches, and compact each layer to a density equal to adjacent original ground.

### **3.5 TOPSOIL STRIPPING**

- A. Remove sod / grass before stripping topsoil.

- B. Strip turf plant structure to depth as specified to prevent intermingling with underlying subsoil or other waste materials.
  - 1. Remove turf plant material from topsoil, including trash, debris, weeds, roots, and other waste materials.

**3.6 DISPOSAL**

- A. Disposal: Remove surplus soil material, unsuitable topsoil, obstructions, demolished materials, and waste materials including trash and debris, and legally dispose of them off Owner's property.
  - 1. Separate recyclable materials produced during site clearing from other nonrecyclable materials. Store or stockpile without intermixing with other materials and transport them to recycling facilities.

**END OF SECTION 02230**

**PART 1 - GENERAL**

**1.01 SECTION SUMMARY**

- A. Partial removal and reinstallation of an underground lawn irrigation system for the area as shown and specified on the Drawings.
- B. Description of Work:
  - 1. The work includes, but is not necessarily limited to, the following:
    - a. Modifications to an automatic irrigation system with electric/manual control including piping, fittings and accessories.
    - b. Testing and instruction.
    - c. Excavating and backfilling irrigation system work.
    - d. Maintenance and warranty.
  - 2. The extent of the alterations to the existing irrigation system is shown on the Drawings.

**1.02 RELATED WORK OF OTHER SECTIONS**

- A. EARTHWORK Division 2

**1.03 QUALITY ASSURANCE**

- A. It is the intent of these Specifications and Drawings to modify the existing irrigation system. Therefore, any items not specifically noted but, reasonably necessary for the intent of a complete installation, shall be furnished. The system shall efficiently and uniformly irrigate all areas designated and perform as required by the Contract Documents.
- B. QUALIFICATIONS
  - 1. The work of this Section shall be performed by a qualified and experienced installer, acceptable to the Owner or Owner's Representative. The term "Installer" as used herein, shall mean a firm of established reputation which is regularly engaged in and which maintains a regular force of workmen skilled in the installation of the type of work specified in this section.
  - 2. Before approval, the Installer shall submit to the Owner's representative three (3) copies of a list of several comparable projects of similar work that the Installer has completed within the past five years with job

locations, names of the owners, their telephone numbers and dates on which the work on each project was started and completed.

C. REFERENCE STANDARDS:

1. Materials, equipment, and methods of installation shall comply with the applicable requirements of the authorities having jurisdiction including the following codes and standards:

- a. National Fire Protection Association, National Electrical Code
- b. American Society for Testing and Materials (ASTM)
- c. National Sanitation Foundation (NSF)
- d. American Society of Agricultural Engineers (ASAE)

D. Excavating, backfilling, and Compacting Operation: as specified.

E. Obtain Owner's Representative's acceptance of installed and tested irrigation system.

**1.04 WARRANTY**

A. Warranty new components of the irrigation system and all related equipment and accessories within the project limits for a period of eighteen (18) months from the date of substantial completion against all defects in workmanship and/or material.

B. The warranty period will commence upon acceptance of substantial completion by the Owner for a complete system and/or any portion thereof has been put into operation and acceptable to the Owner's representative.

C. Defects caused by vandalism, damage by vehicles, acts of God, fire or acts of neglect by others are not included in the warranty.

**1.05 PROJECT SITE CONDITIONS**

A. Locate and identify existing underground and overhead services and utilities within contract limit work areas. Provide adequate means of protection of utilities and services designated to remain. Utilities damaged during site work operations shall be repaired at Installer's expense.

B. When uncharted or incorrectly charted record drawings of underground piping or other utilities and services are encountered during site work operations, notify the Owner's Representative and applicable utility company immediately to obtain procedural directions. Cooperate with the applicable utility company in maintaining active services in operation.

- C. Examine the areas and conditions under which site work is to be performed. Promptly notify the Owner's Representative of unexpected sub-surface conditions. Do not proceed with the work until unsatisfactory conditions are corrected.
- D. Protect irrigation components beyond the project limits from damage caused by site work operations. Replace or repair and restore damaged items to original condition. This will be at the decision of Owner's Representative.
- E. The remaining portions of the existing irrigation system beyond the project limits shall be operational during the contract period.
- F. During zone valves, rotor head, and swing joint pipe removals, the lateral pipe shall be capped and sealed to prevent contamination of the system.

#### **1.06 SUBMITTALS**

- A. Refer to and comply with Section 01300, Submittals, for procedure and additional submittal criteria.
- B. Product Data: Submit all manufacturer's technical data, catalog cuts and installation instructions for all products and equipment specified.
- C. Record Drawings:
  - 1. Submit one (1) set of "As-built" drawings showing actual construction. The drawings shall indicate exact field locations of all sprinkler heads, piping, valves and miscellaneous equipment for the irrigation system with in the project limits.
- D. Submit all product warranties to Owner's Representative.

#### **1.07 DELIVERY, STORAGE, AND HANDLING**

- A. Deliver irrigation system components in manufacturer's original undamaged and unopened containers with labels intact and legible.
- B. Deliver plastic piping in bundles, packaged to provide adequate protection of pipe ends, both threaded or plain.
- C. Store and handle materials to prevent damage and deterioration.

## **PART 2 - PRODUCTS**

### **2.01 IRRIGATION MANUFACTURERS**

- A. Hunter Industries, 1940 Diamond Street, San Marcos, California 92069  
(619) 744-5240.

### **2.2 MATERIALS**

- A. General:

- 1. Wherever in the Drawings and Specifications a particular brand, make of materials, device or equipment is shown or specified, it shall be considered "or equal".
- 2. Provide only new materials, without flaws or defects and of the highest quality of their specified class and kind.

- B. Rotor Head:

- 1. Hunter I-25-04-SS-20

- C. Rotor Head Swing Joint Assembly:

- 1. Three (3) elbow Dura NPT inlet x NPT outlet swing joint. 1"x12" PVC swing joint.

- D. Valves and Valve Boxes:

- 1. HUNTER PGV-151. PGV Series 1-1/2" Globe / Angle Valve with Flow Control.
- 2. NDS Pro-Spec Valve Boxes. Size as appropriate to house valve(s).

- E. Plastic Pipe, Fittings and Connections:

- 1. Provide pipe continuously and permanently marked with manufacturer's name or trade mark, size schedule and type of pipe, working pressure at 73 degrees F and National Sanitation Foundation (NSF) approval.
- 2. Main line piping shall be polyvinyl chloride pipe (PVC), Class 200 SDR-21 PVC as per ASTM D-2241 with gasketed joints conforming to ASTM D-3139. Pipe shall be rigid, unplasticized PVC, extruded from virgin parent material conforming to ASTM D1784, Grade 1, Type 1 standards. Pipe shall be as manufactured by JM Pipe.

3. Lateral line piping shall be polyvinyl chloride pipe, Class 200 solvent weld conforming to ASTM D2241 standards. Pipe shall be rigid, unplasticized PVC, extruded from virgin parent material conforming to ASTM D1784, Grade 1, Type 1 standards. Provide pipe homogeneous throughout and free from visible cracks, holes, foreign materials, blisters, wrinkles, and dents. Pipe shall be as manufactured by JM Pipe.
4. Lateral line pipe fittings shall be ASTM D-2266 Schedule 40 PVC molded fittings suitable for solvent weld, or screwed connections, as manufactured by Lasco.
5. Main line PVC pipe fittings shall be ASTM D2241 PVC molded fittings suitable for gasketed connections, as manufactured by Flo Control.

F. PVC Nipples:

1. PVC nipples shall be Schedule 80, PVC.

### **2.03 ACCESSORY MATERIALS**

A. Drainage Fill at Valve Boxes:

1. Provide ½” washed pea gravel or crushed stone inside and adjacent to exterior of valve boxes.

B. Bedding Material (Sand):

1. Provide as specified in Section 02200, Earthwork.

C. Trench Backfill:

1. Conform to requirements of Topsoil as specified in Division 2, Site Preparation.
2. Suitable excavated materials removed to accommodate the irrigation system work shall be used as fill materials provided it conforms to the requirements of fill as noted above.

D. PVC Solvent Cement:

1. Provide professional grade cement, IPS #711 for Schedule 40 PVC pipe and fittings.

E. PVC Primer/Cleaner:

1. Provide professional grade primer/cleaner, IPC P-70 (purple) primer.

### **PART 3 - EXECUTION**

#### **3.01 SYSTEM DESIGN**

- A. The design intent for the modified irrigation system is to adequately irrigate all infield mix areas where noted on the Drawings.
- B. The location of sprinkler heads, valves and pipe shown on the Drawings are generally diagrammatic to the extent that swing joints, off sets and all pipe fittings are not shown. Exact location and type of piping, sprinkler heads, valves and other components is to be designed by the Contractor for the Owner's Representative's approval of shop drawing submission.

#### **3.02 PREPARATION**

- A. Layout and stake the location of the sprinkler heads and piping.
- B. Final system layout shall meet the Owner's Representative's approval for acceptance.
- C. Contractor shall supply all stakes and equipment necessary to layout system.
- D. Coordinate irrigation work with sod areas installation schedule as to have irrigation available at time of the turf establishment.

#### **3.03 INSTALLATION**

- A. Interior Plumbing:
  1. Protect and utilize existing interior piping and fittings.
- B. Main Line Isolation Valve:
  2. Protect and utilize existing main line isolation valves.
- C. Backflow Preventer:
  1. Protect and utilize existing backflow preventer.
- D. Excavating and Backfilling (if required):
  1. Excavate trenches of sufficient depth and width to permit proper handling and installation of pipe and fittings.

2. Excavate to depths required to provide 2" depth of sand bedding material for piping when unsuitable bearing materials are encountered.
3. Install main line irrigation lines with a cover of eighteen inches (18") based on finished grades.
4. Install lateral irrigation lines with a cover of fourteen inches (14") based on finished grades.
5. Fill trench to match adjacent grade elevations with fill material approved by the Owner's Representative. Place and compact fill in layers not greater than 6" depth.
  - a. Fill bottom 3" of trench with 3" sand for pipe bed.
  - b. Fill to within 10" of final grade with approved excavated fill material.
6. Excavate trenches and install piping and fill during the same working day. Do not leave open trenches or partially filled trenches open overnight.

**E. Pipe**

1. Install pipe and pipe fittings in accordance with manufacturer's installation instructions. Provide for thermal expansion and contraction.
2. Allow joints to set at least 24 hours before pressure is applied to the system.
3. Maintain pipe interiors free of dirt and debris. Close open ends of pipe by acceptable methods when pipe installation is not in progress.
4. All penetrations to be watertight. Penetrations and seals shall be acceptable to the Owner's Representative.
5. Mate plastic to metal joints with plastic male adapters.

**F. Sprinklers, Fittings, and Accessories**

1. Install fittings, valves, sprinkler heads, risers and accessories in accordance with manufacturer's instructions, except as otherwise indicated on or as detailed on the drawings.

2. Install all rotor heads with flex pipe swing joints as shown on the drawings.
  3. Obtain Owner's Representative's review and acceptance of height for risers, spray heads quick coupling valves.
- G. Valve Assemblies
1. Protect and utilize existing valves.
- H. Controller
1. Protect and utilize existing controller.
- I. Controller Power Supply
1. Protect and utilize controller power supply.
- J. Rain Sensor
1. Protect and utilize existing rain sensor.
- K. Control Wiring
1. Protect and utilize existing wiring system.

### **3.04 FLUSHING, TESTING AND ADJUSTMENT**

- A. After piping is installed and before rotor heads are installed, open control valves and flush out the system with full head of water.
- B. Cap all risers and perform system testing upon completion of lateral pipe installation. All pipes shall be tested 100 PSI for 24 hours. During this time a visual inspection shall be made for leaks. All leaks shall be repaired and the lines retested until satisfactory.
- C. Adjust all electric automatic valve control stems and pressure regulating valves for system balance and optimum performance.
- D. Adjust all spray heads and risers for proper distribution of water over the pattern coverage.

- E. After the system has been installed, test the entire system and demonstrate that the entire system meets coverage requirements and automatic controls function properly.
- F. Notify the Owner's Representative seventy-two (72) hours prior to testing.

**3.05 CLEANING AND DISPOSAL OF WASTE MATERIAL**

- A. Perform clean-up during installation of the work and upon completion of the work. Remove from site all excess materials, soil, debris, and equipment as fast as it accumulates.
- B. Restore and repair all disturbed or damaged areas resulting from irrigation installation operations to original condition in a manner acceptable to the Owner's Representative.
- C. Stockpile, haul from site, and legally dispose of water materials, including unsuitable excavated materials, rock, trash, and debris.

**3.06 FINAL REVIEW AND ACCEPTANCE**

- A. When all work has been completed and upon receipt of a written notice (at least ten (10) days prior to the anticipated review), a final review of the irrigation system will be made by the Owner's Representative, upon written notice requesting such a review.
- B. Upon final review and acceptance, the Owner's Representative will notify the Owner in writing, as to final acceptance of the irrigation system. Date of the final acceptance by the Owner is at substantial completion and this date is the date beginning the warranty period.
- C. Any irrigation equipment item required under this contract that is malfunctioning or in need of repair is to be removed and replaced by the Contractor. All replacements are to be of equipment and/or material originally specified. The cost of replacement is to be borne by the Contractor, except for replacements resulting from removal or loss due to the occupancy of the project in any part, vandalism, or acts of neglect on the parts of others, physical damage by vehicles, fire, lightning or other acts of God.

**3.07 MAINTENANCE**

- A. During the warranty period, maintain the irrigation system to insure complete operation of the entire system. Adjust and repair all settled piping, trenches and sprinkler heads within the project limits. Correct all defective or damaged work as soon as possible.

**END OF SECTION 02810**

## **PART 1 - GENERAL**

### **1.1 GENERAL REQUIREMENTS**

- A. These specifications are for the renovation of the baseball and softball infields and the rugby field. The scope of the project shall include but may not be limited to the removal of existing turf, limited root zone mix, and laser grading of existing and new infield mixes, fraise mowing, vertical slit drainage, core aeration, topdressing, over-seeding, within the defined area, and replacement with new specified materials, and repair or replacement of irrigation heads within the defined area.

### **1.2 RELATED DOCUMENTS**

- A. Drawings and general provisions of Contract, including General and Supplementary (or Special) Conditions apply to this section.

### **1.3 SUMMARY**

- A. This section includes: (All work by Contractor)
1. Submission of infield mixes, sand, and topsoil materials for testing.
  2. Fine grading of the field surface, including compaction of the infield skin.
  3. Fraise mowing, vertical slot drainage, core aeration, topdressing, and over-seeding of rugby field.
  4. Replacement of affected sections of irrigation system.
  5. Sodding of a portion of the infield area.
  6. Construction of the warning track.
  7. Initial fertilizing and other amendments.
  8. Providing all labor, materials, equipment, and services to complete the work as specified herein.
- B. Related Sections include the following:
1. Division 1 Section 01500 "Construction Facilities and Temporary Controls" for temporary utilities, temporary construction and support facilities, temporary security and protection facilities, and temporary erosion and sedimentation controls procedures.
  2. Division 1 Section 01010 "Summary of Work" for verifying utility locations and for recording new measurements.
  3. Division 2 Section 02200 "General Earthwork" for soils materials, excavating, backfilling and site grading.
  4. Division 2 Section 02920 "Topsoil" for finish grading including preparing and placing topsoil and testing.

- 5. Division 2 Section 02810 "Irrigation" for alterations of the irrigation system.
  
- C. Field contractor to verify existing conditions prior to commencement of work.

#### **1.4 DEFINITIONS**

- A. Finish Grade: Elevation of finished surface of planting soil, sod, or mix.
- B. Root zone mix (sand base): Growing medium of homogeneously blend of sand and peat.
- C. Infield Mix: Soil mix used for the skinned area of the infield.
- D. Warning Track: A system of warning track mix located along the perimeter of the field.
- E. Subgrade: Surface or elevation of subsoil remaining after completing excavation, or top surface of a fill or backfill immediately beneath planting soil.
- F. Subsoil: All soil beneath the topsoil layer of the soil profile and typified by the lack of organic matter and soil organisms.

#### **1.5 SUBMITTALS**

##### **A. SOIL PRODUCT SUBMITTALS**

All reports, submittals, samples, test results, and product information shall be sent to the Owner for approval.

- 1. Sand Product: Prior to beginning any work in the field, submit to the Owner one 5-pound sample of the sand product, name of material source, and laboratory tests certifying the material meets the specifications.
- 2. Infield Mixes: Prior to beginning any work in the field, submit to the Owner one 5-pound sample of the sand product, name of material source, and laboratory tests certifying the material meets the specifications.
- 3. Warning Track Materials: Prior to beginning any work in the field, submit to the Owner a one gallon sample of the sand product, name of material source, and laboratory tests certifying the material meets the specifications.
- 4. Sod: The Contractor shall submit a sample of the soil or sand on which the sod is grown to the Owner for testing of particle size analysis and approval.

5. The Contractor is responsible for all costs associated with obtaining, containerizing, labeling and transporting the samples, as well as all reporting costs. Eastern shall pay for laboratory tests which are found acceptable. Re-testing of previously rejected material shall be provided at the Contractor's expense.
  6. Inspection Costs: The Contractor shall bear all costs for re-testing rejected material including all costs required to gain approval of rejected materials.
- B. Submit the Certification of the sod plant mix to the Owner for approval.
- C. Certification of Grass Seed: From seed vendor for each grass-seed monostand or mixture, stating the botanical and common name, percentage by weight of each species and variety, and percentage of purity, germination, and weed seed. Include the year of production and date of packaging.
1. Product Certificates: For fertilizers, from manufacturer.
  2. Pesticides and Herbicides: Product label and manufacturer's application instructions specific to Project.

## **1.6 PROJECT CONDITIONS**

- A. Contractor shall not begin sodding until approved to do so by the Owner and after review of the baseball sand base (rootzone mix) grade preparation.
- B. Contractor shall not begin seeding until approved to do so by the Owner and after review of the rugby field preparation.

## **1.7 BIDDER QUALIFICATIONS**

- A. Contractors submitting bids shall be and have been actively and directly engaged in constructing sand-based natural turf systems and provide proof of five (5) or more of such sports turf installations that have been in active use for three or more years.

In addition, the bidder shall be a member organization of the American Sports Builders Association, Golf Course Builders Association, and/or have a Certified Sports Turf Manager on site for the duration of the project.

Any bidder not meeting these requirements shall submit the following list for consideration as a qualified bidder:

Listing of Work similar to that required under this contract with phone numbers, client contacts, and installation dates.

Listing of employees to be used on the job and their experience level.

Listing of equipment proposed for construction.

Project Schedule: List in order types of work to be performed and length of time for each.

### **1.8 DELIVERY, STORAGE AND HANDLING**

- A. Packaged Materials: Deliver packaged materials in containers showing weight, analysis, and name of manufacturer. Protect materials from deterioration during delivery, and while stored at site.
- B. Infield Mixes: The mix materials are to be blended at an off-site (off-playing field) location and approved through laboratory results prior to delivery to the site. Deliver approved lots in clean, washed and covered trucks to eliminate contamination during transportation. Stockpile of material on site to be coordinated with the General Contractor and placed in an area free of contamination such as low, wet and/or refuse areas.
- C. Sod: Time delivery so that sod will be placed within 24 hours after stripping. Protect sod against drying and breaking of rolled strips.

### **1.9 COMPLETION DATES/INSPECTIONS**

- A. Substantial Completion: **Date of substantial completion shall occur on or before July 24, 2020.** At this date, the Owner shall perform a final inspection if notified in writing, 7 days prior, for “Substantial Completion”.
- B. The following items shall be provided per specification in order for the playing fields to be defined as “Playable” or “Substantially Complete”.
  - 1. All improvements performed for the rugby field such as, fraise mowing, vertical slot drainage, core aeration, topdressing, and over-seeding work.
  - 2. Root depth of 3-1/2” averaged over the newly sodded areas as determined by 8 core samples equally representative of the infield and outfield areas.
  - 3. Absence of all joints and cracks in sod installation as to appear “seamless”.
  - 4. Dense, green, consistent turf void of any bare or patchy areas of more than 3 square inches.
  - 5. Smooth, level playing surface compacted and level to grading tolerances.
  - 6. Turf maintained at a height of 1” to 1-1/2” mowed with reel-type equipment.
  - 7. Stockpiling of field materials per specification.
  - 8. Installation of warning track as needed.
  - 9. Installation, alterations, and head adjustments for baseball, softball, and rugby field irrigation systems.
  - 10. Installation and laser grading of skinned areas of baseball and softball fields.

11. Installation of bases and plates for baseball and softball fields.

- C. Warranty: The “scope of work” shall be warranted against defect in installation or materials for a period of eighteen months beginning at the date of substantial completion.
1. The following are inclusive of the term “scope of work”:
    - a. Working functions of the irrigation system.
    - b. Final grade tolerances to one-quarter inch in the length of 25’ of finish grade.
    - c. Materials as specified.
    - d. Turf to be true of species and type and free from objectionable weeds and/or grasses.
    - e. The Contractor shall warrant parts and labor necessary to correct any deficiencies in the above.

**PART 2 - PRODUCTS**

**2.1 SAND**

- A. Rugby: Sand for use for the vertical slot drainage shall be a naturally occurring (not manufactured) processed, non-calcareous sand meeting the following particle size criteria:

	<u>Sieve Mesh</u>	<u>Diameter of sieve (mm)</u>	<u>Allowable range % retained</u>
Gravel	10	2.00	0 - 5%
Very coarse sand gravel	18	1.00	0 - 20% combined w/
Coarse	35	0.50	at least 60%
Medium	60	0.25	in this range
Fine	100	0.15	15% maximum
Very fine	270	0.05	3% maximum
Silt		0.002	5% maximum
Clay		< 0.002	3% maximum

In addition, there should be 100% passing the No.5 screen (4 mm), and no more than 10% combined very fine sand, silt, and clay. The sand shall have a coefficient of uniformity of 2.3 to 3.5.

**2.2 INFIELD MIX FOR SKIN**

- A. Baseball: DuraEdge Collegiate mix produced by Read Custom Soils, Hingham MA (781-828-6303) or an approved equal.

The infield mix shall be a blend of clean, dry clay with a washed mason type sand resulting in a weed free mixture that is reddish brown in color, meeting the following particle size:

- a) A total sand content of 65 - 69%
- b) The combined amount of medium, coarse, and very coarse sand (0.25 - 1 mm) shall be greater than or equal to 45%.
- c) The combined amount of silt and clay shall be 31 - 35%
- d) The ratio of silt to clay, otherwise noted as SCR, shall be 0.5 to 1.
- e) There shall be no particles larger than 3 mm.
- f) There shall be no more than 5% retaining on a 2 mm screen.

- B. Softball: DuraEdge **Recreational** mix produced by Read Custom Soils, Hingham MA (781-828-6303) or an approved equal.

The infield mix shall be a blend of clean, dry clay with a washed mason type sand resulting in a weed free mixture that is reddish brown in color, meeting the following particle size:

- a) A total sand content of 70 - 75%
- b) The combined amount of medium, coarse, and very coarse sand (0.25 - 1 mm) shall be greater than or equal to 40%.
- c) The combined amount of silt and clay shall be 25 - 30%
- d) The ratio of silt to clay, otherwise noted as SCR, shall be 0.5 to 1.
- e) There shall be no particles larger than 3 mm.
- f) There shall be no more than 5% retaining on a 2 mm screen.

### **2.3 WARNING TRACK**

- A. Warning Track Mix: “3/16” Red Warning Track” as produced by Partac Peat Corporation One Kelsey Park Great Meadows, New Jersey 07838 or approved equal.
- B. Warning Track Subbase: Washed, evenly graded mixture of crushed stone, or crushed or uncrushed gravel, ASTM D 448, coarse aggregate grading size 57, with 100 percent passing a 1-1/2” sieve and not more than 5 percent passing a No. 8 sieve.

### **2.4 SOD**

- A. Sod shall be grown on mineral soil high in sand (> 50%), with no more than 10% very fine sand. The sod shall be high quality, free of weeds, disease and insects, and of good color and density. Soil on which the sod is grown shall be tested by the owners testing agent, and approved by the designers. Acceptable sources include Tuckahoe Sod (Hammonton, NJ) and East Coast Sod Farms (Pilesgrove, NJ). Alternates shall be approved by the designers. Sod shall be machine cut at a

uniform soil thickness necessary for plant viability during the harvest - transport - installation cycle. Individual pieces of sod shall be cut to the suppliers' standard width and length. Sod grass mix shall consist of the one hundred (100%) percent to be Kentucky Bluegrass. The sod shall be a blend of at least three Kentucky bluegrass varieties of which at least 60% shall include two of the following: America, Brilliant, Princeton-105, Showcase, Apollo, Unique, Blacksburg, Eclipse, Northstar, Jefferson, Conni, Wildwood, Rambo, Nustar, Midnight, Liberator, Blackstone, Total Eclipse, and Rugby II. Alternates shall be approved by the designers.

- B. The sod shall be machine cut at a uniform soil thickness of **two (2") inches**,  $\pm$  one eighth (1/8") inch, at the time of cutting. Measurement for thickness shall exclude top growth and thatch. Individual pieces of sod shall be cut to the supplier's standard width and length. Maximum allowable deviation from standard widths and lengths shall be five (5%) percent. Broken pads and torn or uneven ends will not be acceptable. Sod shall be at least on (1) year old and no more than (2) years old from time of original seeding.
- C. Sod shall be furnished and installed in rectangular sod strips measuring twelve (12") inches or sixteen (16") inches in width and from four feet to six feet (4'-6') in length, stored in rolls with the grass top side inverted so that the topsoil is to the exterior. Big roll sod will also be accepted.
- D. Sod shall be harvested, delivered and installed within a period of twenty four (24) hours. Soil on sod pads shall be kept moist at all times.

## **2.5 SEED**

- A. Grass Seed: Fresh, clean, dry, new-crop seed complying with AOSA's "Rules for Testing Seeds" for purity and germination tolerances.
- B. Seed Species:
  - 1. Quality: State-certified seed of grass species as listed below for solar exposure.
  - 2. Athletic Seed Mix: Proportioned by weight as follows:
    - a. 30% American Kentucky Bluegrass
    - b. 20% NuGlade Kentucky Bluegrass
    - c. 20% Moonlight Kentucky Bluegrass
    - d. 30% Grand Slam 2 Perennial Ryegrass

## **2.6 FERTILIZER**

- A. Starter Fertilizer: Starter fertilizer shall be a commercial turfgrass starter having the analysis of 18-24-6 or similar. A minimum of seventy five (75%) percent of total nitrogen shall be derived from urea, methylene ureas, and/or monoammonium or diammonium phosphate.
- B. Liming (used when required to adjust pH of topsoil as determined by the soil

analysis):

1. Ideally the lime would be applied at a rate sufficient to bring the pH of the root zone mix to between 6.0 and 7.0 as determined by the pH-testing lab, during the blending process. If that is not possible the lime shall be applied prior to sodding at a rate recommended by the soil testing lab and incorporated to a depth of 4 inches.
- C. Apply pre-plant fertilizer amendments as directed by a qualified soil testing lab, such as University of Massachusetts Lab, A&L Eastern, or CLC Labs.

## **2.7 PESTICIDES**

- A. General: Pesticide, registered and approved by the EPA, acceptable to authorities having jurisdiction, and of type recommended by manufacturer for each specific problem and as required for Project conditions and application. Do not use restricted pesticides unless authorized in writing by authorities having jurisdiction.
- B. Pre-Emergent Herbicide (Selective and Nonselective): Effective for controlling the germination or growth of weeds within planted areas at the soil level directly below the mulch layer.
- C. Post-Emergent Herbicide (Selective and Nonselective): Effective for controlling weed growth that has already germinated.

## **PART 3 - EXECUTION**

### **3.1 PREPARATION FOR FIELD SURFACES**

- A. Protection of Work: Contractor to protect all on-going work, so as not to delay work due to weather or project related construction. This includes but is not limited to the use of tarps, geotextiles, plywood, etc.
- B. All work on athletic field preparation shall be in strict conformance with the requirements of these specifications including, but not limited to: verification of required grades, compaction, loosening hauling, and depositing of earth materials, excavation and removal of unsuitable material.
- C. Baseball Sod Layout: Layout areas to receive sod as indicated on the drawings and as directed by the Owner. Obtain approval from the Owner. The area shall be formed using an appropriated edging material sufficient to hold material and of appropriate height. Edging shall be removed prior to sodding and compaction of field. Edges of the skinned infield should meet the turf areas evenly. Ridges and/or depressions that may pool water will not be permitted.
- D. Baseball Sod Placement: Remove existing sod and excavate partial existing root

zone mix to receive thicker cut of new sod, taking care to prevent contamination of the sand base (root zone mix).

- E. Turn off irrigation system and remove irrigation heads and connected swing pipe within the area of renovation. Cap and seal remaining sections of irrigation system so no contaminants enter the system. Irrigation zones for baseball and softball outfields shall remain operational to maintain sod area.
- F. The root zone mix shall be spread with low ground pressure tracked equipment. Under no circumstance shall trucks be driven on placed root zone mix. Laser grade all turf areas to finish grades as indicated on the Drawings within a tolerance of 1/4 inch in 25 feet. All finish grading shall be performed with small tractors outfitted with flotation (turf-type) tires. When no grades are shown, areas shall have a smooth and continual grade between existing or fixed controls and elevations shown on plans. Roll, scarify, rake and level as necessary to obtain true even field surface. All turf areas shall slope to drain. Finish grades shall be approved by the Owner.
- G. Compaction of root zone mix: Operate the irrigation system one full cycle or until water is known to be draining through the subsurface drain system. Fill in low spots to finish grade with root zone mix as appropriate and water in thoroughly. The process shall be repeated as necessary to bring the field to finish grade within the tolerances described. Finish grades shall be verified by survey instruments. Provide copy of survey to Owner for approval. If a light roller is used to obtain field grade, the surface shall be scarified before sodding. Field compaction shall not exceed the bulk density as performed in laboratory testing.
- H. Rugby Field: Layout area to receive improvement as indicated on the drawings and as directed by the Owner. Obtain approval from the Owner. The area shall be marked either by stakes or painted lines. Ensure irrigation system is protected prior to start of field work. Determine if goal posts will require removal in order to perform the work.

### **3.2 LASER GRADING OF INFIELD SKIN AREAS (BASEBALL & SOFTBALL)**

- A. Remove plates and bases.
- B. Remove and protect irrigation heads and system within infield limits.
- C. Place supplemental infield mix across infield areas as required and lightly compact to 85 to 90% maximum standard proctor density. The density can often be obtained by rolling with a 1 ton roller. Scarify the surface between new material and existing material. Repeat as necessary until finish grade elevation is achieved.
- D. If unable to achieve optimum compaction, lightly water prior to compacting.

- E. The mix shall be finish graded with a laser guided device that allows grade accuracy to  $\pm 1/8$  inch. The finished surface of the infield shall be smooth and free of any visible dips, humps, or other blemishes that would hinder removal of surface water though positive surface drainage.

### **3.3 BASEBALL WARNING TRACK**

- A. Mix shall be installed per manufacturer's instructions. Material shall be applied to a depth of 4 inches. Subbase gravel material shall be rolled to 95% standard proctor density to a depth of and elevation as shown on the drawings.

### **3.4 BASEBALL SODDING**

- A. Root zone mix shall be watered to moisten it prior to laying sod.
- B. The sod shall be laid smoothly, edge to edge, and where continuous or solid sodding is called for on the plans sod shall be laid with the longest dimension parallel to the contours. Vertical joints between sods shall be staggered. Immediately after laying, sod shall be pressed firmly into contact with the sod bed by light rolling, or by other approved methods so as to eliminate all air pockets, provide true and even surfaces, insure knitting and protect all exposed sod edges, but without displacement of the sod or deformation of the sod surface.
- C. Sod may be placed from April 15<sup>th</sup> to November 1<sup>st</sup> as long as the ground is not frozen and the irrigation system is operational.
- D. Sod shall be harvested, delivered and transplanted within a period of twenty four (24) hours.
- E. Sod shall be watered immediately during and after installation to prevent drying. It shall then be thoroughly irrigated to a depth sufficient that the underside of the new sod pad, and soil immediately below the pad, is thoroughly wet.
- F. Top Dressing: In addition to the initial top dressing during the sod installation to fill in gaps between sod, two lifts of  $1/4$  inch will be required using the same rootzone mix as specified previously. Additional top dressing as required to ensure a smooth and safe playing surface may be required. Care should be used to avoid smothering sod. One top dressing to occur prior to both initial completion and substantial completion.
- G. Aerification: Aerification of the field will be required at least one time prior to playing on the field and only after the sod is firmly knitted. Removal of cores will be required. Only hollow tine equipment shall be utilized with a maximum of  $1/2$  inch diameter with 3"x 3" grids.
- H. Sod Replacement/Patching: Verified sod of the same type and source shall be used when necessary.

- I. Fertilization: Four days after sod installation apply by spray, Pana Sea plus, a liquefied sea plant extract at 4 ounces per 1000 square feet. Apply an additional application two weeks later. One week after the installation of the sod and the initial fertilization, apply one half pounds of N of Scott's product 8420 (9-0-32) or equivalent per 1000 square feet every 5-7 days until rootzone surface is stabilized and turf clippings are able to be collected. At that time take soil and tissue samples and submit to the testing laboratory assigned by the Owner's testing agency for results. These results and recommendations shall be submitted to the Testing Agent for consideration and approval. An appropriate fertilizer and rate shall be applied as recommended by the fertility tests throughout Substantial Completion. Both granular and liquid fertilizers can be used.
- J. Weed and Pest Control: All treatments will comply with local and state codes. Contractor will be required to utilize only commercially licensed personnel and applicators to perform these operations. Treatments will be made according to the needs of the field as determined by the Owner and Testing Agent.
- K. Irrigation System: The system shall be adjusted on a continual basis as necessary to maintain specified coverage. Heads shall be adjusted to elevation when necessary. All repairs to lines, valves, heads, field mixes, etc. shall be performed in a timely manner repairing to the previous condition and specifications. Heads shall be cleaned as necessary to insure full pop-up and flush lowered positions.
  - 1. Controller shall be set for appropriate watering intervals with adequate instruction to the Owner.

**3.5 RUGBY TURF RENOVATION (FRAISE MOWING, DECOMPACTION, SLOT DRAINAGE, AERATION, TOPDRESSING, AND OVERSEEDING)**

- A. Renovate existing rugby turf as indicated on the drawings.
- B. Remove undesirable sod and vegetation while leaving desirable grass crowns and root systems from turf areas by **Fraise mowing**. The Contractor shall utilize Koro FieldTopMaker (FTM) equipment with a working depth of 0-50mm. Contractor to provide the appropriate equipment to receive and dispose of debris material from mowing operations.
- C. Provide **deep decompaction** using an Air2G2 by laterally injecting pressurized air up to 12-inches beneath the surface of the soil in a diameter of up to 9 feet. Provide coverage across the field area as recommended by the manufacturer.
- D. Provide vertical slot drainage and aeration by utilizing a **Verti-Quake** rotary aerator along with a **Redexim Sand Master** unit to fill the voids made with the aerator with sand. The aerator shall operate at a depth of 8 inches and create channels of ½" to ¾" in width at 10 inches apart. Approximately three (3) trailer

loads (22 tons per load of sand) will be required to infill the channels over the limits of the field area.

- E. **Core aerate** the entire field area. Utilize aeration equipment with a hollow tine size of 3/4 inch diameter and a penetration depth of 4 to 6 inches, spaced at 2"x2". Remove all cores from field area.
- F. **Top-dress** field area with approximately one truck load (22 tons per load) of sand with a Dakota Top-Dressing applicator of approved equal. Application of sand shall be a minimum of 1/4 inch but not to exceed 1/2 inch thickness. Use drag mats to spread top-dressing into core holes.
- G. Remove topsoil containing foreign materials, such as oil drippings, fuel spills, stones, gravel, and other construction materials resulting from Contractor's operations, and replace with new planting soil. Remove waste and foreign materials, including weeds, soil cores, grass, vegetation, and turf, and legally dispose of them off Owner's property.
- H. Renovate turf damaged by Contractor's operations, such as storage of materials or equipment and movement of vehicles.
  - 1. Reestablish turf where settlement or washouts occur or where minor regrading is required.
  - 2. Install new planting soil as required.
- I. Apply initial fertilizer required for establishing new turf. Install new planting soil to fill low spots to meet finish grades within the field area.
  - 1. Soil Amendment(s): according to requirements of Section 329113 Soil Preparation.
  - 2. Initial Fertilizer: Commercial fertilizer applied according to manufacturer's recommendations.
- J. Sow seed with spreader or overseeding machine. Do not broadcast or drop seed when wind velocity exceeds 5 mph.
  - 1. Evenly distribute seed by sowing equal quantities in two directions at right angles to each other.
  - 2. Do not use wet seed or seed that is moldy or otherwise damaged.
- K. Sow seed at a total rate of 8 to 10 lb/1000 sq. ft.
- L. Over-seed lightly into top 1/8 inch of soil, roll lightly, and water with fine spray.
- M. Water newly planted areas and keep moist until new turf is established.

**3.6 PESTICIDE APPLICATION**

- A. Apply pesticides and other chemical products and biological control agents according to requirements of authorities having jurisdiction and manufacturer's written recommendations. Coordinate applications with Owner's operations and others in proximity to the Work. Notify Owner before each application is performed.
- B. Post-Emergent Herbicides (Selective and Nonselective): Apply only as necessary to treat already-germinated weeds and according to manufacturer's written recommendations.

**3.7 FIELD QUALITY CONTROL**

- A. Testing Agent: Shall test and approve, as required, all agronomical materials before placement and perform subsequent tests during construction necessary to guarantee performance of the filed system.
- B. Acceptance of Sod: At the end of each day, the Owner's Representative shall inspect in place sod for conformance with requirements. Unacceptable sod shall be removed immediately from the site and replaced the following work day. This preliminary acceptance does not guarantee final acceptance at Substantial Completion.
- C. Sod Root Depth: Sod shall display a minimum average of roots 4" in depth prior to acceptance of substantial completion.

**3.6 SATISFACTORY TURF (BASEBALL & RUGBY)**

- A. Turf installations shall meet the following criteria as determined by Owner:
  - 1. Satisfactory Seeded Turf: At end of maintenance period, a healthy, uniform, close stand of grass has been established, free of weeds and surface irregularities, with coverage exceeding 90 percent over any 10 sq. ft. and bare spots not exceeding 5 by 5 inches.
  - 2. Satisfactory Sodded Turf: At end of maintenance period, a healthy, well-rooted, even-colored, viable turf has been established, free of weeds, open joints, bare areas, and surface irregularities.
- B. Use specified materials to reestablish turf that does not comply with requirements, and continue maintenance until turf is satisfactory.

**3.7 POST INSTALLATION MAINTENANCE**

- A. General: Maintain and establish turf by watering, fertilizing, weeding, mowing, trimming, replanting, and performing other operations as required to establish

healthy, viable turf. Roll, regrade, and replant bare or eroded areas and remulch to produce a uniformly smooth turf. Provide materials and installation the same as those used in the original installation.

- B. Fill in as necessary soil subsidence that may occur because of settling or other processes. Replace materials and turf damaged or lost in areas of subsidence.
- C. Apply treatments as required to keep turf and soil free of pests and pathogens or disease. Use integrated pest management practices whenever possible to minimize the use of pesticides and reduce hazards.
- D. Watering: Install and maintain temporary piping, hoses, and turf-watering equipment to convey water from sources and to keep turf uniformly moist to a depth of 4 inches.
- E. Schedule watering to prevent wilting, puddling, erosion, and displacement of seed or mulch. Lay out temporary watering system to avoid walking over muddy or newly planted areas.
- F. Water turf with fine spray at a minimum rate of 1 inch per week unless rainfall precipitation is adequate.
- G. Mow turf as soon as top growth is tall enough to cut. Repeat mowing to maintain specified height without cutting more than one-third of grass height. Remove no more than one-third of grass-leaf growth in initial or subsequent mowings. Do not delay mowing until grass blades bend over and become matted. Do not mow when grass is wet. Schedule initial and subsequent mowings to maintain the following grass height:
  - 1. Mow Kentucky bluegrass, annual ryegrass, and red fescue to a height of 1-1/2 to 2 inches.
- I. Turf Postfertilization: Apply commercial fertilizer after initial mowing and when grass is dry.
- J. Use fertilizer that provides actual nitrogen of at least 1 lb/1000 sq. ft. to turf area.
- K. Turf Maintenance Service: Provide full maintenance by skilled employees of landscape Installer. Begin maintenance immediately after each area is planted and continue until acceptable turf is established, but for not less than the following periods:
  - 1. Seeded Turf: 60 days from date of planting completion.

When initial maintenance period has not elapsed before end of planting season, or if turf is not fully established, continue maintenance during next planting season.

2. Sodded Turf: 30 days from date of planting completion.
- L. Repeat mowing to maintain specified height without cutting more than 1/3 of grass height. Remove no more than 1/3 of grass-leaf growth in initial or subsequent mowings.
- M. Following Substantial Completion, the Owner will maintain turf areas by watering, fertilizing, weeding, mowing, trimming, reseeding, and other operations as necessary.

**3.8 INSPECTION AND ACCEPTANCE**

- A. The Owner shall inspect the field upon written request by the Contractor. The request shall be received at least ten (10) days before the anticipated date of inspection.
- B. Final acceptance will not be granted until all seeded and sodded areas are in satisfactory condition.
- N. If the grass is in satisfactory condition, the Contractor's care and maintenance responsibilities will end. If the grass stand is unsatisfactory, the Contractor's maintenance responsibility shall continue, including all those maintenance activities identified above, until an acceptable stand of grass is achieved.

**3.9 CLEAN UP**

- A. Absolutely no debris may be left on the site. Excavated material shall be removed as directed. Repair any damage to site or structures to restore them to their original condition, as directed by the Owner, at no cost to the Owner.

**END OF SECTION 02910**

**SECTION 02920 – TOPSOIL**

**PART 1 – GENERAL**

**1.1 GENERAL REQUIREMENTS**

- A. Work of this Section, as shown or specified shall be in accordance with the requirements of the Contract Documents.

**1.2 SECTION INCLUDES**

- A. Work of this Section includes labor, materials, equipment and services necessary to complete the topsoil work for restoration areas which includes but is not necessarily limited to the following:
  - 1. Preparing sub-grades in areas to receive topsoil.
  - 2. Providing new topsoil, if required.
  - 3. Testing topsoil.
  - 4. Delivering and spreading new topsoil.
  - 5. Fine grading.

**1.3 RELATED SECTIONS**

- A. Section 02200 General Earthwork
- B. Section 02230 Site Preparation

**1.4 QUALITY ASSURANCE**

- A. Work of this Section will be performed by approved Landscape Firm with good reputation, successful record over past 5 years on projects of similar size and complexity and which maintains regular force of experienced workers skilled in work of this section.
- B. Construction Administrator will approve, and reserves right to inspect source of new topsoil. Inspection of new topsoil source will not affect right of rejection on delivery or during progress of work if topsoil does not meet quality and other material requirements, nor relieve Contractor of responsibility for requirements.
- C. Testing:
  - 1. Provide and pay for materials testing by recognized, independent testing service approved by Construction Administrator.
  - 2. Take representative samples for testing from materials as they are delivered or where they are found on-site in presence of and in manner satisfactory to Construction Administrator as follows:
    - a. New topsoil: Each 100 cy.
  - 3. Provide testing of following materials for analysis data indicated:
    - a. Topsoil:

- i. Topsoil chemical tests including acidity-alkalinity test and organic constituents analysis.
- ii. Topsoil physical tests including sieve analysis for range outlined in art. 2.01, para. A, subpara.1.a.
- iii. Each analysis shall be accompanied by service's recommendations for bringing topsoil to true range of pH values listed below for the following uses.

Lawns and Grasses – pH 6.0 – 6.8

## **1.5 SUBMITTALS**

- A. Deliver submittals to Construction Administrator and obtain his approval prior to ordering materials or beginning work or as otherwise required. Time delivery to allow reasonable review period and prevent delays.
- B. Submit name and location of proposed supply source of new topsoil with certified analysis by recognized, independent testing service including tests for quality requirements in Part. 2.01, para. A., subpara. I. of proposed topsoil
- C. Submit test reports for topsoil

## **1.6 DELIVERY, STORAGE, AND HANDLING**

- A. Keep topsoil from being mixed with subsoil, subgrade materials, other stockpiled materials, waste materials, debris and other contaminants.

## **1.7 JOB CONDITIONS**

- A. Coordinate work under this Section closely with work of other trades wherever such work affects or is affected by work included herein.
- B. Divide site into logical work parcels scheduling and completing work in each area in continuous operation so that grass and planting work can follow expeditiously.
- C. Fine grading shall be accepted by Construction Administrator prior to seeding.
- D. Do not work with soggy, muddy or frozen topsoil or install topsoil during rain or on subgrades, which are muddy, under water or frozen.
- E. Topsoil:
  1. Provide new topsoil from off-site source to complete work.
  2. Any excess topsoil will remain property of Owner.

## **PART 2 – PRODUCTS**

### **2.1 MATERIALS**

- A. New Topsoil: Imported, fertile, friable material of loamy character; of uniform grade without admixture of subsoil material; reasonably free of clods, stiff clay, hardpan, large stones, plants, roots, sticks, glass, waste building materials, rubbish, debris and other deleterious or objectionable materials.
  - 1. Quality:
    - a. One hundred percent by weight will pass 1” mesh sieve and 97% to 100% will pass ¼” mesh sieve. In material passing ¼” mesh sieve there will not be less than 20% or more than 65% passing No. 200 mesh sieve as determined by wash test made in accordance with standard test ASTM DII 40.
    - b. Topsoil will contain not less than 4% nor more than 20% organic matter in portion of sample which passes ¼” mesh sieve when determined by wet combustion method on sample dried at 105 degrees C.
    - c. Topsoil will have true range of pH values from 7.0 – 5.5
  - 2. Source will be single origin with supply of sufficient size to meet complete project needs and one of the following:
    - a. Area from which no topsoil has been previously taken and which possesses such uniformity as to offer assurance to the Construction Administrator that product will be homogeneous and will meet specified requirements.
    - b. Area which is or has been in cultivation within past ten years and is producing or has produced fair to good yield of farm crops within unusual fertilization, or area which would be readily cultivable for farm crop, and is supplied with good normal drainage.
    - c. Approved topsoil supplier or producer of manufactured, soil-based growing medium with a stockpile of material uniformly treated and of consistent nature meeting required characteristics and qualities.

## **PART 3 – EXECUTION**

### **3.1 INSPECTION**

- A. Examine proposed areas to be topsoiled and conditions of installation. Do not start topdressing work until unsatisfactory conditions are corrected.

### **3.2 INSTALLATION**

- A. Distribute, uniformly spread topdressing of soil in areas to be seeded with grass and not otherwise planted, surfaced or paved as indicated on Drawings.

- B. While spreading topsoil, remove excessive amounts of large clods, hard lumps, rocks, roots, sticks, vegetative matter and other debris.
- C. Fine grade topsoiled areas:
  - 1. Shape and rake surfaces to lines, finish grades and thickness required providing a smooth, uniform surface with an uninterrupted drainage pattern free of hollows and pockets.
  - 2. Fill, trim, blend and feather proposed grades to meet surrounding existing terrain in smooth transition without abrupt level changes.
  - 3. Pitch surfaces for positive drainage, shedding runoff in direction of drainage courses or drain structures.
- D. Rake surfaces clean of debris and stones 1/2" or larger in any dimension.
- E. Compact topsoiled areas with approved roller weighing approximately 500 lbs. Regrade to eliminate bumps and depressions until satisfactory finish grade is obtained.
- F. Stockpile and spread excess topsoil not required for work in locations and to depths and grades determined by Construction Administrator.

### **3.3 PROTECTION**

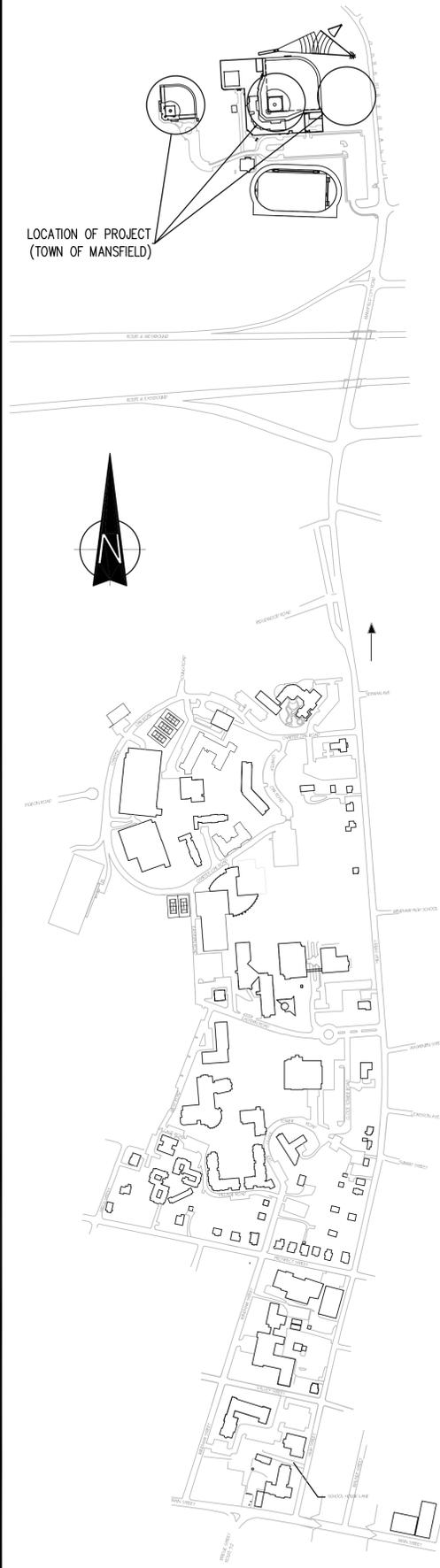
- A. Protect fine graded areas from traffic and erosion and keep free of trash and debris.
- B. Repair, re-shape and re-establish finished grades where areas settle, erode, are disturbed and damaged.

### **3.4 CLEANING**

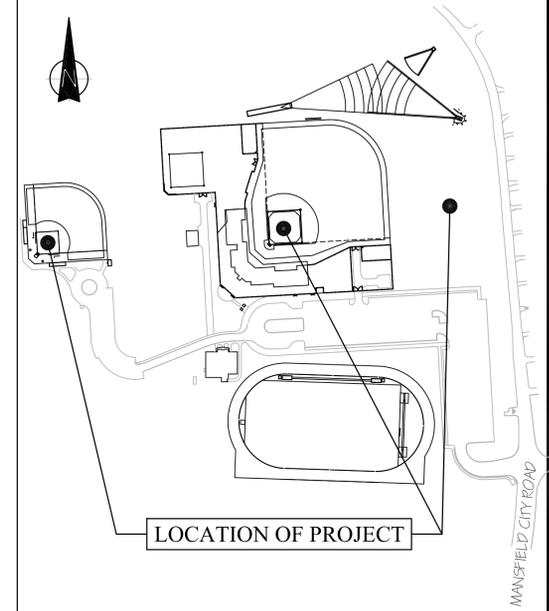
- A. Clean topsoiled areas of debris, making them suitable for grass work prior to acceptance by Construction Administrator.
- B. Remove trash and debris from site and dispose of it legally. Do not dispose of rocks, stones, boulders, vegetative materials, trash or other debris in existing wooded or shrub areas.

**END OF SECTION 02920**

SITE PLAN



LOCATION PLAN



**EASTERN CONNECTICUT STATE UNIVERSITY**

WILLIMANTIC, CONNECTICUT

**BASEBALL, SOFTBALL, & RUGBY  
FIELD RENOVATION**

**PROJECT # ECSU 2020-8  
Facilities Management & Planning**

ELSA NUÑEZ  
PRESIDENT

April 2020

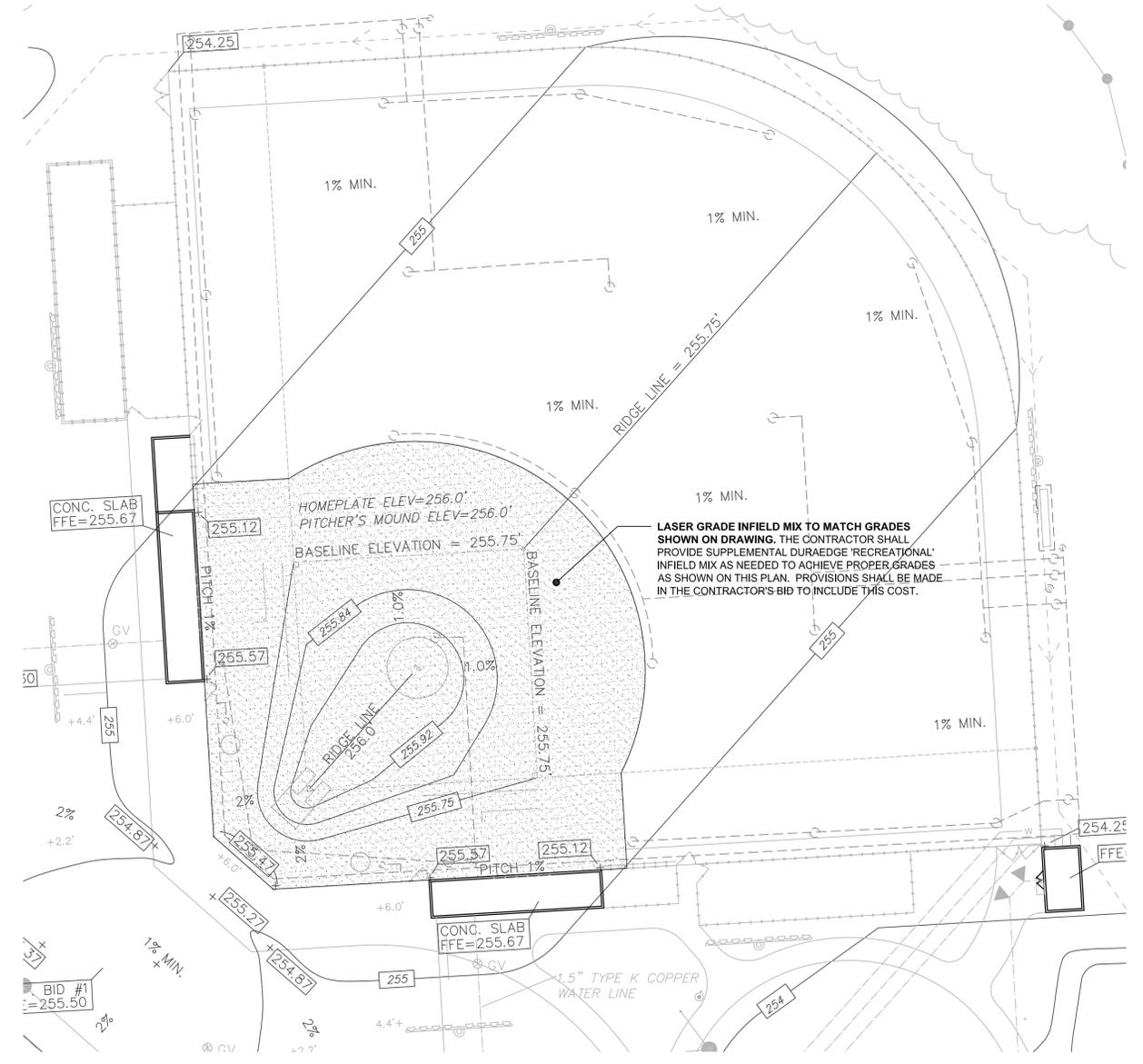
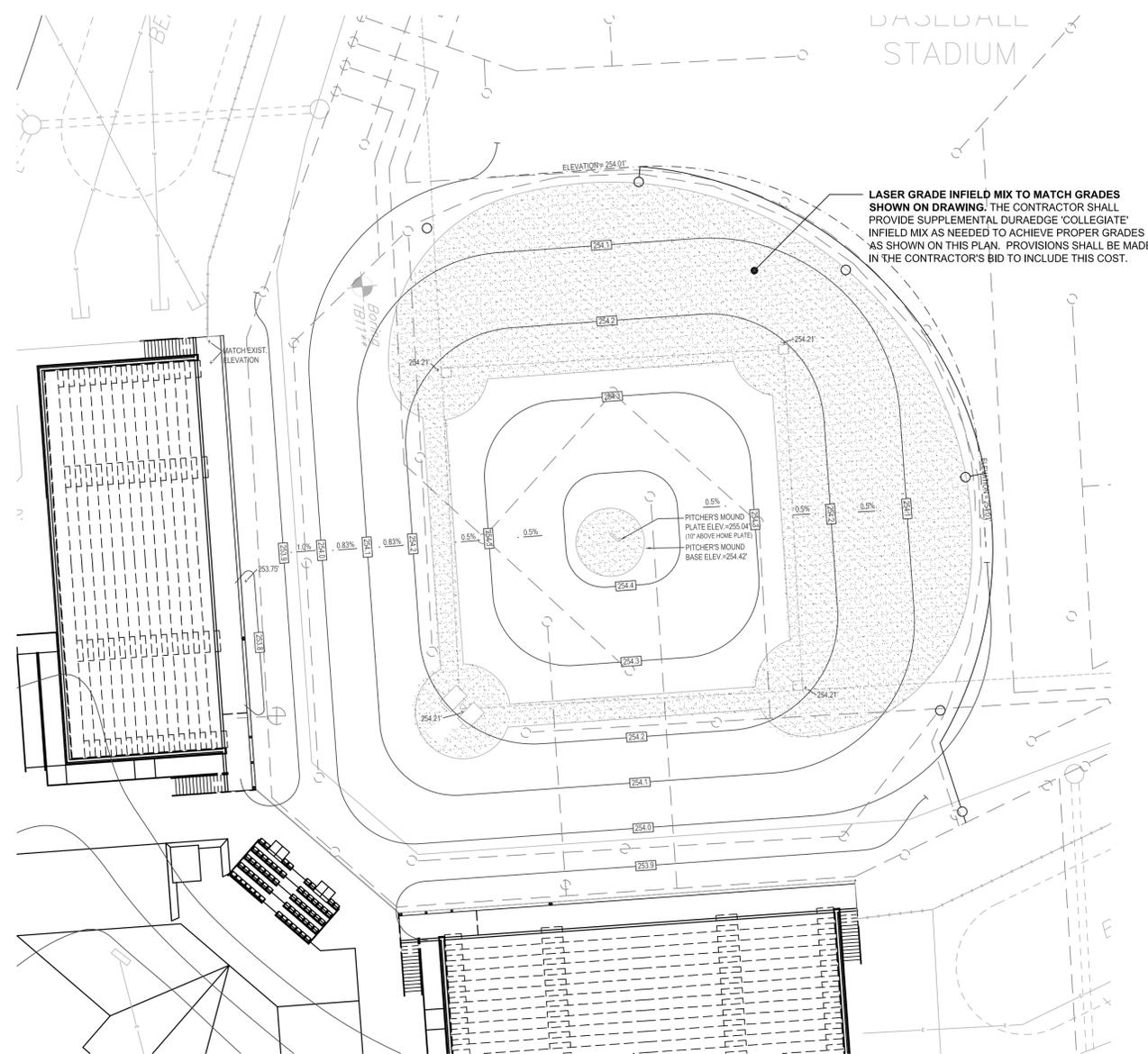
**LIST OF DRAWINGS**

-	COVER
SP-1	SITE PLAN
GR-1	GRADING PLAN
DN-1	DETAIL SHEET

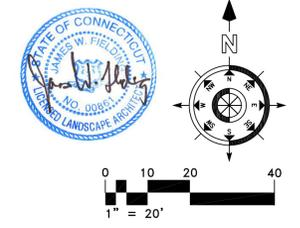


JAMES W. FIELDING, RLA, LEED AP  
COORDINATOR OF UNIVERSITY CONSTRUCTION





- GENERAL NOTES:**
1. THE CONTRACTOR SHALL FURNISH ALL MATERIALS, LABOR, TOOLS, AND EQUIPMENT NECESSARY FOR LASER GRADING OPERATIONS AND INSTALLATION OF SUPPLEMENTAL INFIELD MIX ON ALL AREAS DETAILED ON THIS DRAWING.
  2. THE CONTRACTOR SHALL MAINTAIN A CLEAN AND ORDERLY JOB SITE. ALL EXCESS MATERIALS SHALL BE REMOVED FROM THE CONSTRUCTION AREA AND PROPERLY DISPOSED OF OFF SITE. SCRAP SHALL BE REMOVED IN THE SAME MANNER. MATERIAL SHALL NOT BE DISPOSED OF ON SITE.
  3. THE CONTRACTOR SHALL RESTORE GRASSED AREAS TO THEIR ORIGINAL CONDITION AFTER THE WORK HAS BEEN COMPLETED.
- GRADING NOTES:**
1. THE CONTRACTOR SHALL VERIFY THE ELEVATIONS OF THE INFIELD TO ENSURE THERE IS POSITIVE PITCH. THE CONTRACTOR SHALL AVOID CREATING DIPS OR DEPRESSIONS. ANY DEPRESSIONS CREATED SHALL BE RECTIFIED AT THE CONTRACTOR'S EXPENSE.
  2. THE CONTRACTOR SHALL PROVIDE SUPPLEMENTAL DURAEDGE INFIELD MIXES TO ACHIEVE PROPER GRADES AS SHOWN ON THIS PLAN. PROVISIONS SHALL BE MADE IN THE CONTRACTOR'S BID TO INCLUDE THIS COST.

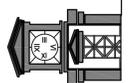


No.	Revision/Issue	Date

PROJECT NAME:  
**Baseball, Softball, & Rugby Field Renovation**

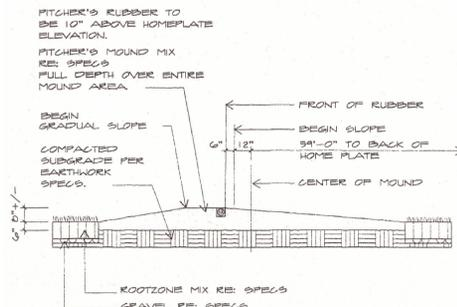
DRAWING NAME:  
**Grading Plan**

Project No.: **ECSU 2020-8**  
 Date: **4/15/2020** Drawing No.: **GR-1**  
 Scale: **AS NOTED**  
 Plot Size: **24 x 36**

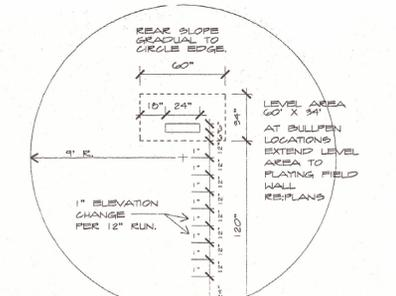


**EASTERN CONNECTICUT STATE UNIVERSITY**

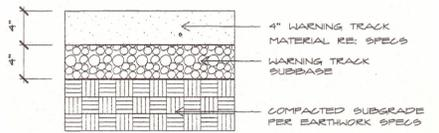
Facilities Management and Planning  
 83 Windham Street, Willimantic CT 06226



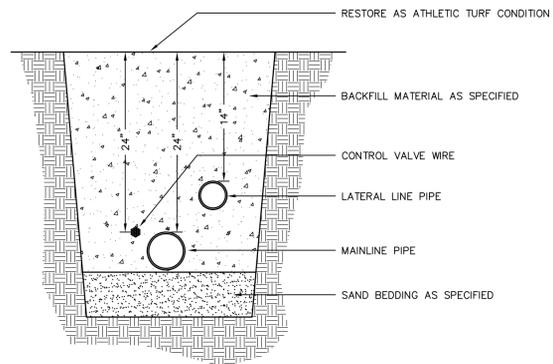
**BASEBALL PITCHERS MOUND SECTION**  
N.T.S.



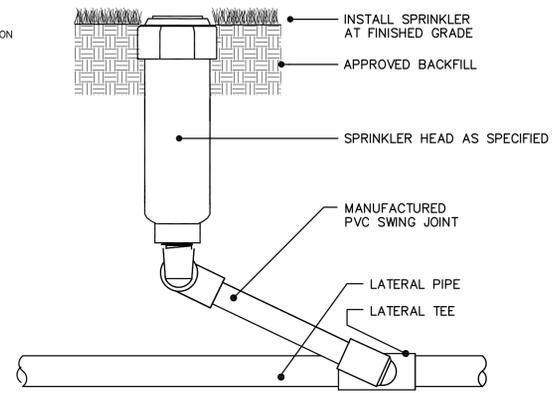
**PITCHING MOUND LAYOUT**  
N.T.S.



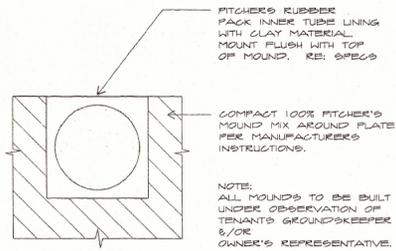
**BASEBALL WARNING TRACK DETAIL**  
N.T.S.



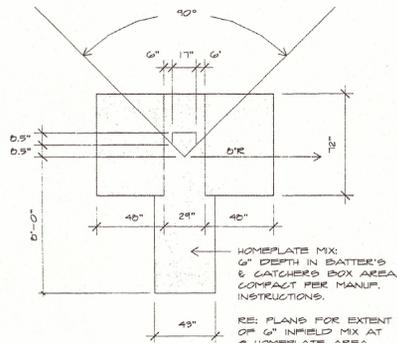
**IRRIGATION TRENCH**  
N.T.S.



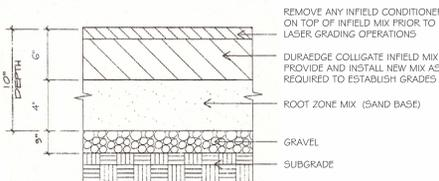
**ROTARY SPRINKLER**  
N.T.S.



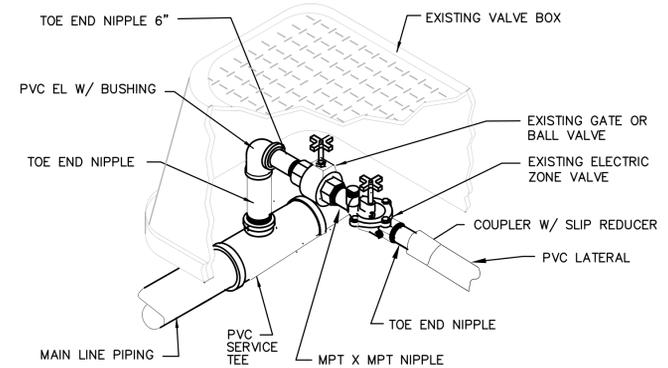
**PLATE INSTALLATION**  
NO SCALE PITCHER'S RUBBER



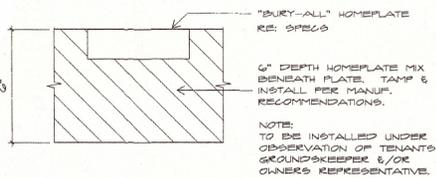
**BASEBALL BATTER'S BOX LAYOUT**  
N.T.S.



**BASEBALL INFELD MIX**  
N.T.S.

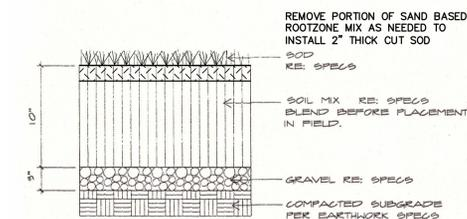


**VALVE ASSEMBLY FOR RELOCATION**  
N.T.S.

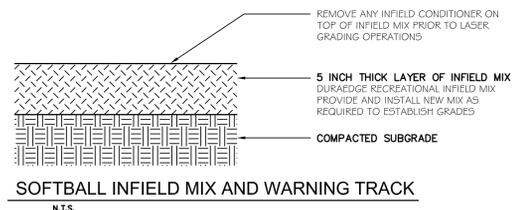


**PLATE INSTALLATION**  
NO SCALE HOMEPLATE

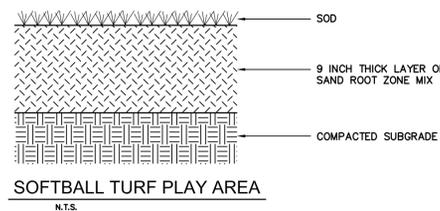
BASE, PLATE, AND LAYOUT DETAILS PROVIDED FOR REFERENCE ONLY



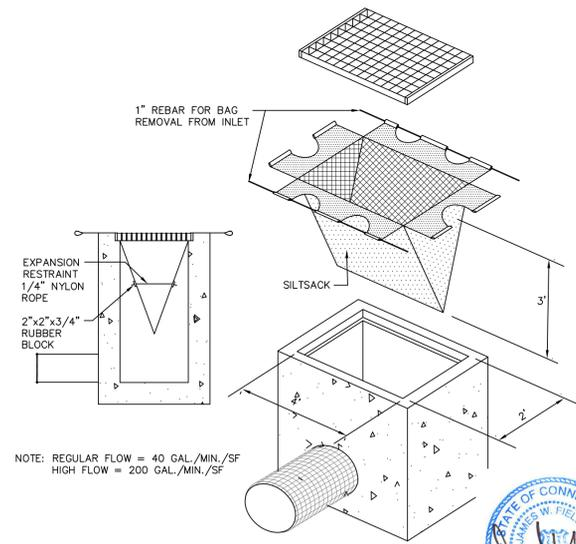
**BASEBALL ROOTZONE MIX**  
N.T.S.



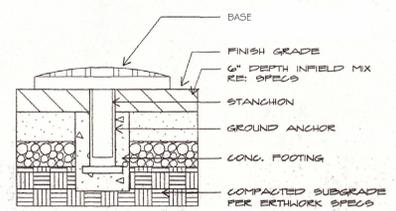
**SOFTBALL INFELD MIX AND WARNING TRACK**  
N.T.S.



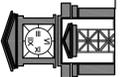
**SOFTBALL TURF PLAY AREA**  
N.T.S.



**SILTSACK DETAIL**  
N.T.S.



**BASE ANCHOR DETAIL**  
NO SCALE



No.	Revision/Issue	Date

PROJECT NAME:

**Baseball, Softball, & Rugby Field Renovation**

DRAWING NAME:

**Detail Sheet**

Project No.:

**ECSU 2020-8**

Date:

**4/15/2020**

Drawing No.:

**DN-1**

Scale:

**AS NOTED**

Plot Size:

**24 x 36**

