

F. H.W. A. REGION NO.	STATE	TOWN	FED. AID PROJ. NO.	PROJ. NO.	YEAR	ROUTE NO.	SHEET NO.	TOTAL SHEETS
1	CONN.	SOUTHINGTON-FARMINGTON PLAINVILLE-WEST HARTFORD NEW BRITAIN-HARTFORD	I-IR-84-3 (155)42	131-145	1982	I-84	1	115

CONNECTICUT DEPARTMENT OF TRANSPORTATION PLAN FOR I-84 BRIDGE DECK REPAIRS

IN THE TOWNS OF
 SOUTHWINGTON FARMINGTON
 PLAINVILLE WEST HARTFORD
 NEW BRITAIN HARTFORD

FROM STA. 105+30.00 TO STA. 173+75.00
 LENGTH _____ FT.

DESIGN SCALES { PLAN 1 IN. = _____ FT.
 PROFILE HOR. 1 IN. = _____ FT. VERT. 1 IN. = _____ FT.
 CROSS SECTIONS 1 IN. = _____ FT.

OTHER SCALES AS NOTED

TO BE MAINTAINED BY THE STATE

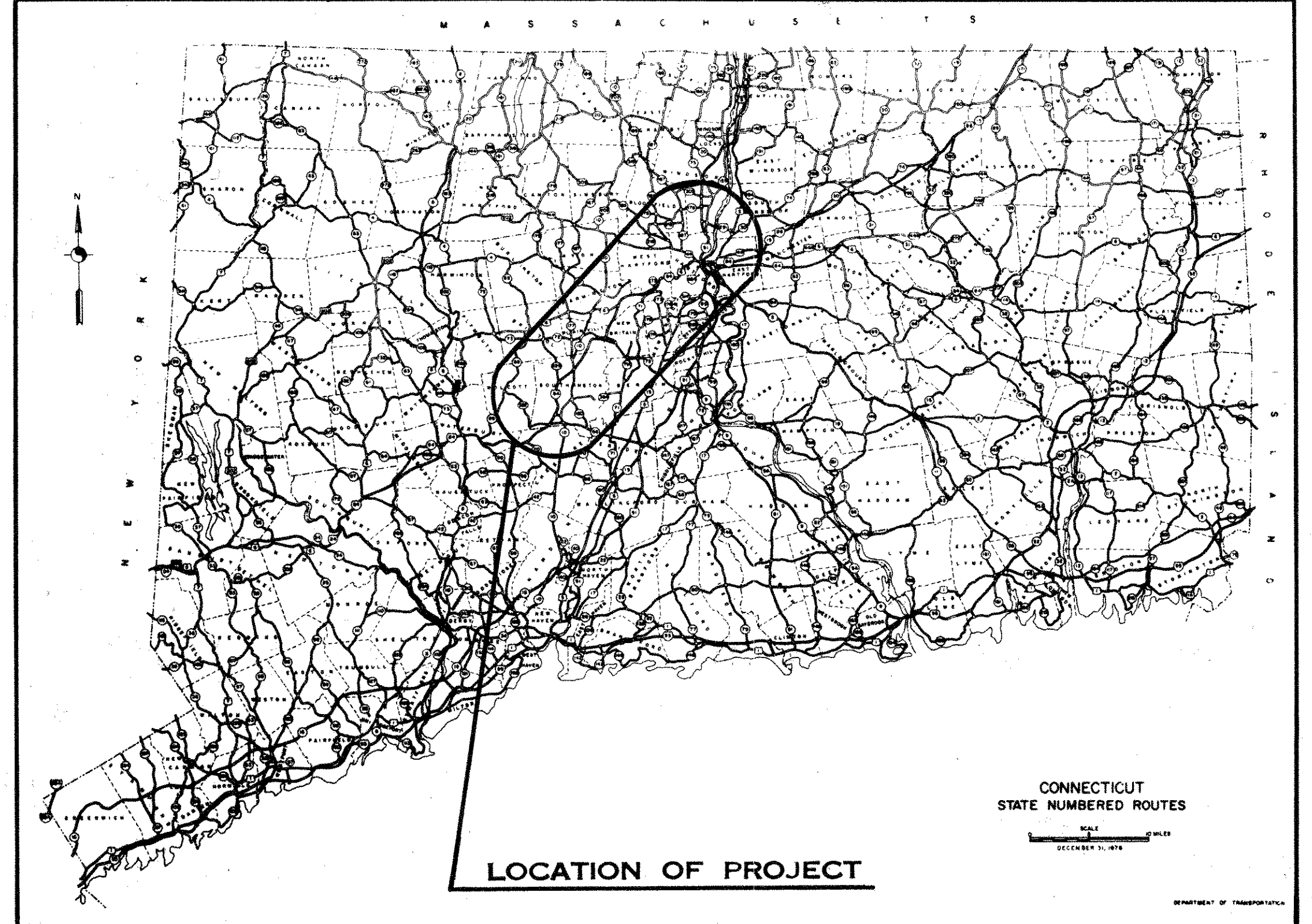
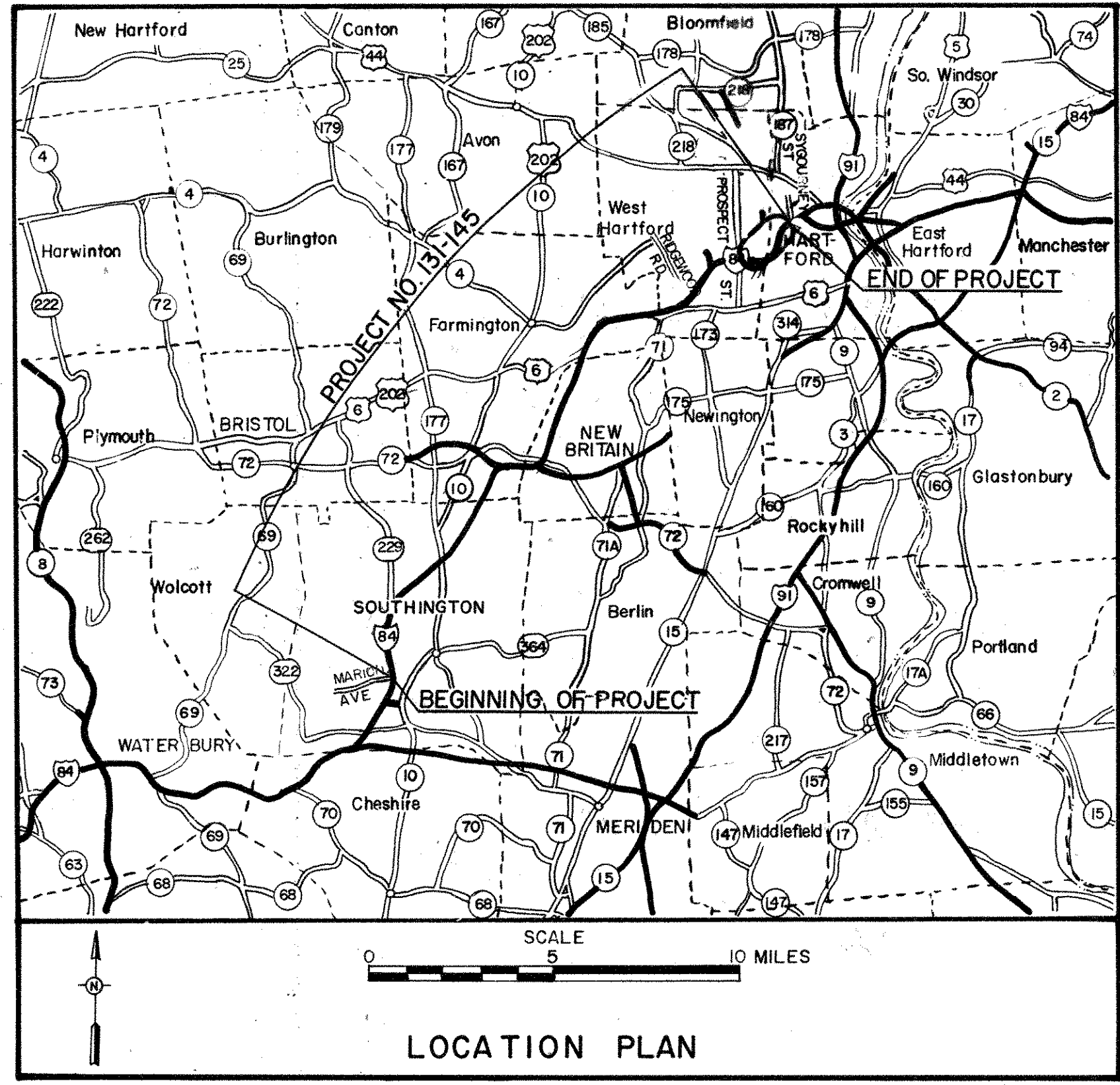

1980 SPECIFICATIONS, FORM NO. 812 INCLUDING
 SUPPLEMENT THERETO DATED JAN. 1982 GOVERN
 ALL ELEVATIONS ON THIS PROJECT

TOWN NO. 131
 PROJECT NO. 145

WHEREVER I-IR-84-3(155)42 APPEARS
 ON THESE PLAN SHEETS, IT SHALL
 READ I-84-3(155)42

JULY 13, 1982

SEPT. 14, 1985

FEDERAL AID PROJECT NO. I-84-3(155)42 CONTRACT 4

STANDARD CONVENTIONS

LIST OF DRAWINGS				
SHEET NO.	TITLE	SHEET NO.	STANDARD SHEETS	FEDERAL HIGHWAY ADMINISTRATION APPROVAL DATE
1	TITLE SHEET	220 F	METAL BEAM RAIL (TYPE R-1)	6-22-73
2-5	INDEX PLANS	222 C	CURBING	11-16-66
6-7	DETAILED ESTIMATE SHEETS	228 D	STEEL FRAME & GRATE-TYPE 'A' FOR TYPE 'C' CATCH BASIN	2-25-76
8-13	TYPICAL CROSS SECTIONS & MISC. SHTS.	228 E	TYPE 'C' CATCH BASIN	2-18-76
14-100	BRIDGE DECK REPAIR PLANS	228 F	STEEL FRAME & GRATE-TYPE 'B' FOR TYPE 'C' CATCH BASIN	3-27-67
101-109	BRIDGE PROTECTIVE FENCE PLANS	415 A	PRESSURE RELIEF JOINT FOR R.C. PAVEMENT	6-8-81
110-115	TRAFFIC SIGNS AND PAVEMENT MARKINGS	822 A	PRECAST CONCRETE MEDIAN BARRIER CURB FOR TEMPORARY TRAFFIC CONTROL	4-29-79
		925 A	PAVEMENT FOR RAILING	9-14-79
		918A		
		918B		

LIST OF DRAWINGS (CONT.)			
SHEET NO.	DESCRIPTION	DATE	REVISED BY
24, 3A, 4A, 5A & Standard Sheets 918A & B	Add for Addendum No. 1	4/14/82	D.G.
115-1	New Sheet Added for Construction Order	7/13/85	J.C.C.

U.S. DEPARTMENT OF TRANSPORTATION
 FEDERAL HIGHWAY ADMINISTRATION

APPROVED: _____
 DIVISION ADMINISTRATOR

DATE _____

SUBMITTED March 25 1982

ENGINEER OF DESIGN [Signature]

APPROVAL RECOMMENDED 3-25 1982

SECTION SUPERVISOR - STATE DESIGN SECTION [Signature]

APPROVED 3/26 1982

MANAGER OF DESIGN [Signature]

INDEX PLAN

BEGINNING OF FEDERAL AID PROJECT NO. I-84-3(155)42
 STATE PROJECT NO. 131-145
 I-84 @ STA. 105+30.00

SOUTHINGTON I-84-3 (155)42 131-145 1982 2A 115

I-84 BRIDGE DECK REPAIRS

SCALE IN FEET
 800' 400' 0 800'

Revised 4/14/82

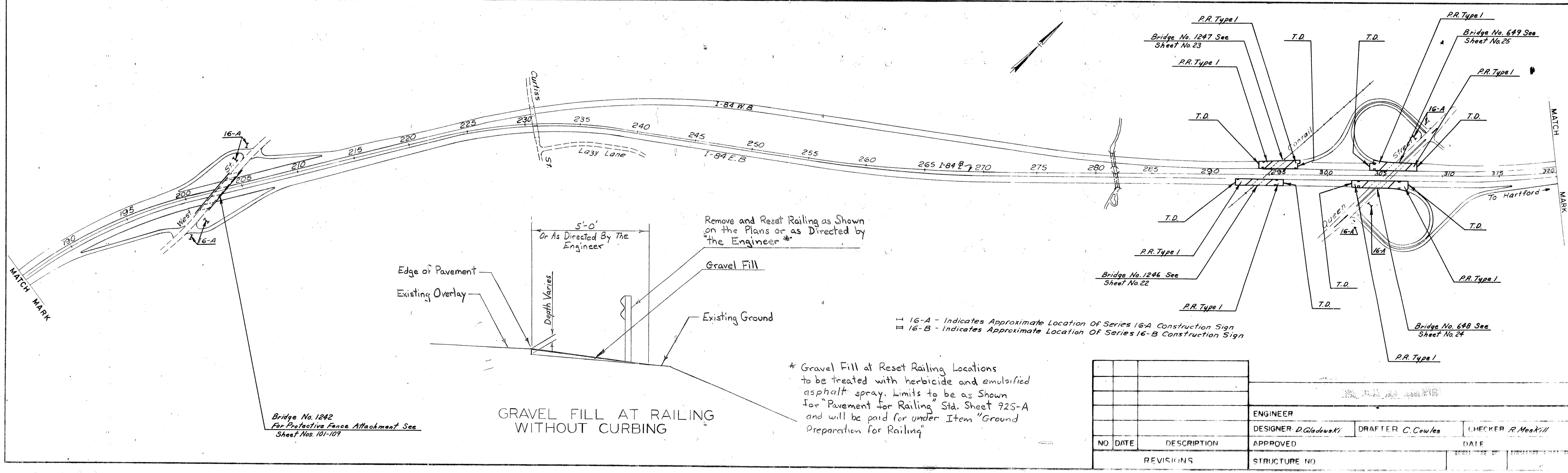
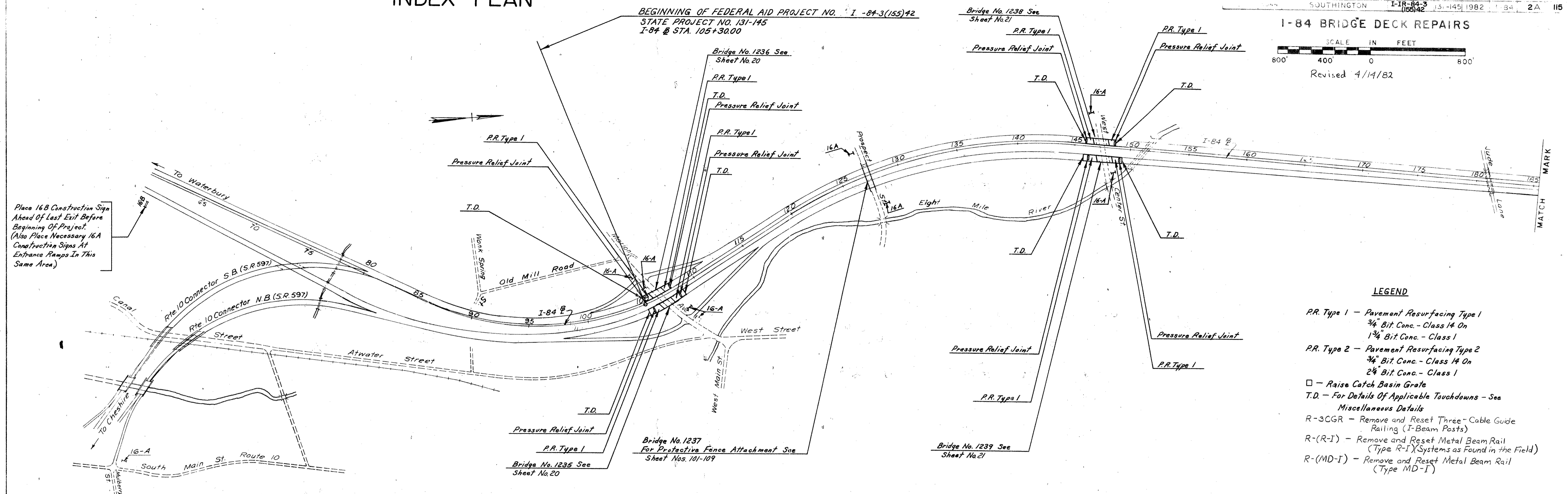

NO		DATE	DESCRIPTION	APPROVED	DATE
REVISIONS		STRUCTURE NO.			
ENGINEER			DESIGNER D. Gladuski	DRAFTER C. Cowles	CHECKER R. Meskill

INDEX PLAN

FOR LEGEND SEE SHEET NO. 2

SOUTHINGTON-FARMINGTON	I-84-3 (165)42	131-145	1982	I-84	3	115
------------------------	-------------------	---------	------	------	---	-----

I-84 BRIDGE DECK REPAIRS

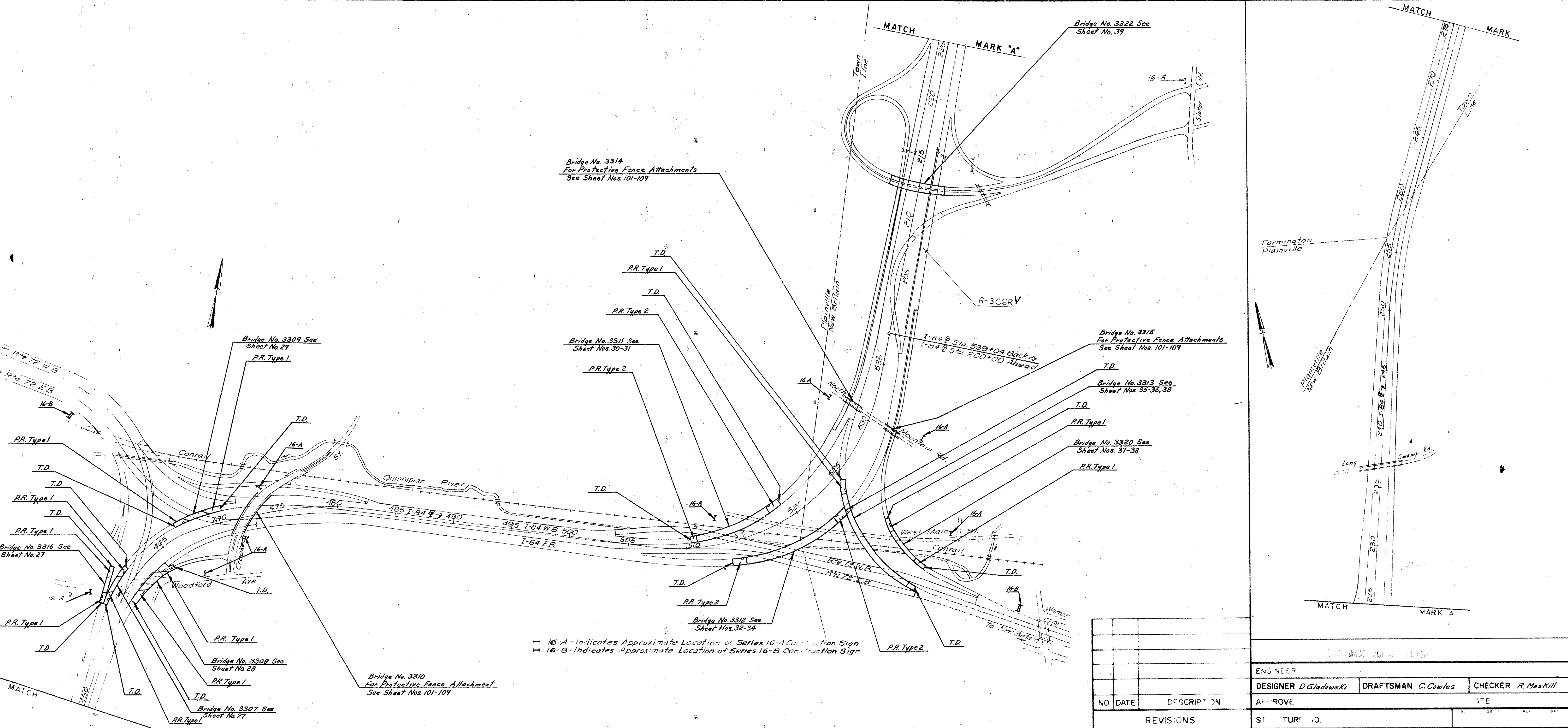
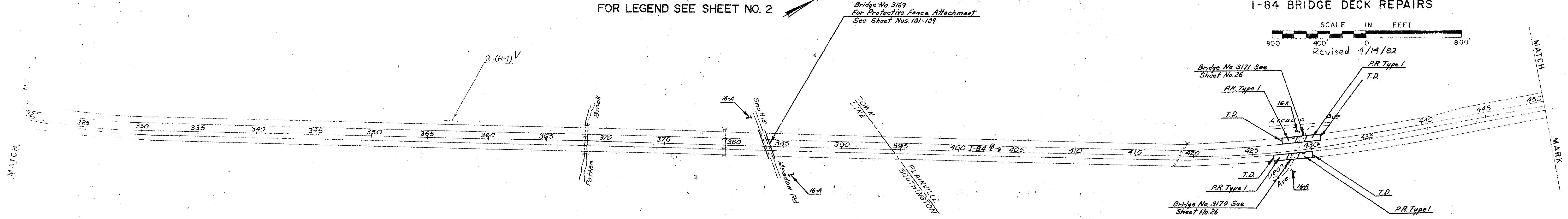
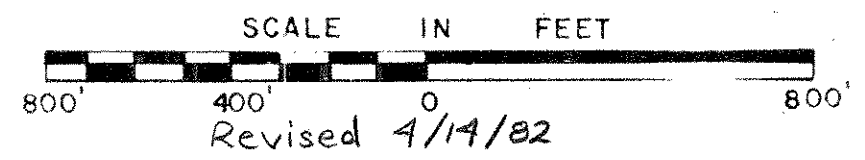

- I 16-A - Indicates Approximate Location of Series 16-A Construction Sign
- II 16-B - Indicates Approximate Location of Series 16-B Construction Sign

REVISIONS		ST	TUR	NO.
NO.	DATE	DESCRIPTION	APPROVE	DATE
		ENGINEER	DESIGNER <i>D. Gladowski</i>	DRAFTSMAN <i>C. Cowles</i>
		CHECKER <i>R. Meskill</i>		

F.R.W.A. DIST.	STATE	TOWN	PROJ. NO.	CONTRACT NO.	YEAR	ROUTE NO.	SHEET NO.	TOTAL SHEETS
CONN.	SOUTHINGTON-FARMINGTON	1-84-3	131-145	1982	1-84	3	115	

INDEX PLAN

FOR LEGEND SEE SHEET NO. 2

I-84 BRIDGE DECK REPAIRS

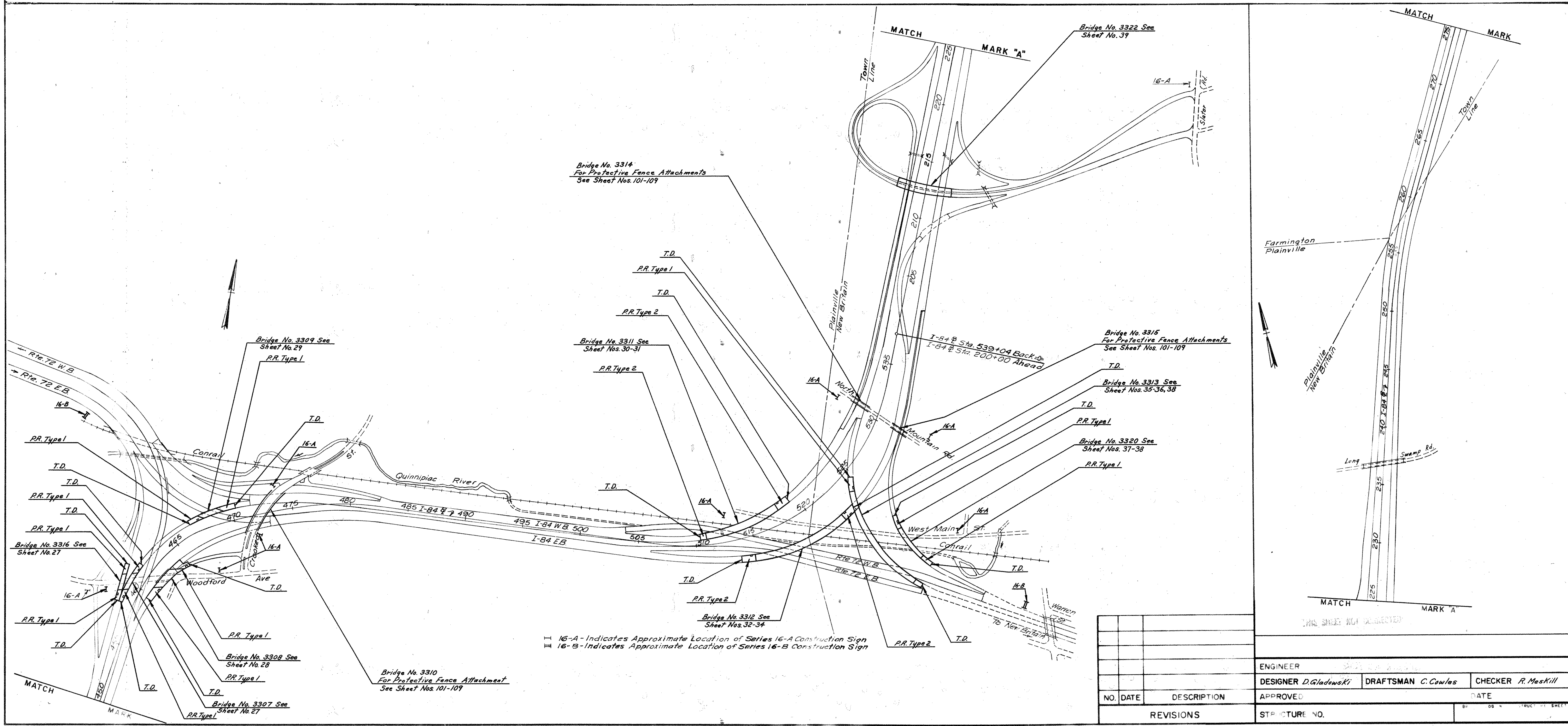
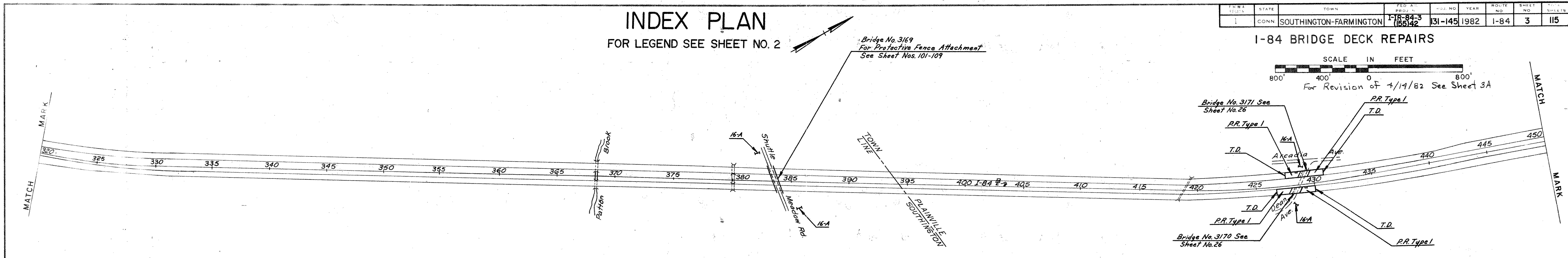
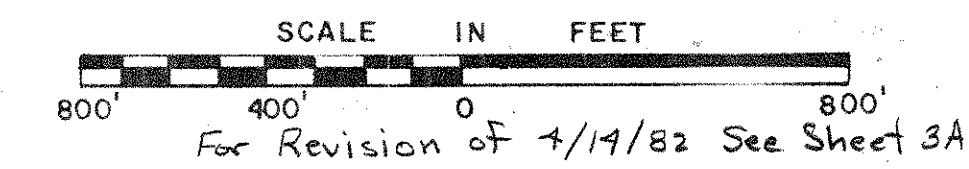

- I 16-A - Indicates Approximate Location of Series 16-A Construction Sign
- II 16-B - Indicates Approximate Location of Series 16-B Construction Sign

NO. DATE		DESCRIPTION	APPROVED	DATE
REVISIONS		STP. CTURE NO.		
ENGINEER		DRAFTSMAN	CHECKER	
DESIGNER D. Gladowski		C. Cawles	R. Meskill	

INDEX PLAN

FOR LEGEND SEE SHEET NO. 2

TOWN	STATE	FED. AID PROJ. NO.	PR. NO.	YEAR	ROUTE NO.	SHEET NO.	TOTAL SHEETS
FARMINGTON-WEST HARTFORD	CONN.	I-IR-84-3 (165)42	131-145	1982	1-84	4	115

I-84 BRIDGE DECK REPAIRS
 For Revision of 4/14/82 See Sheet 4A
 SCALE IN FEET
 800' 400' 0' 800'

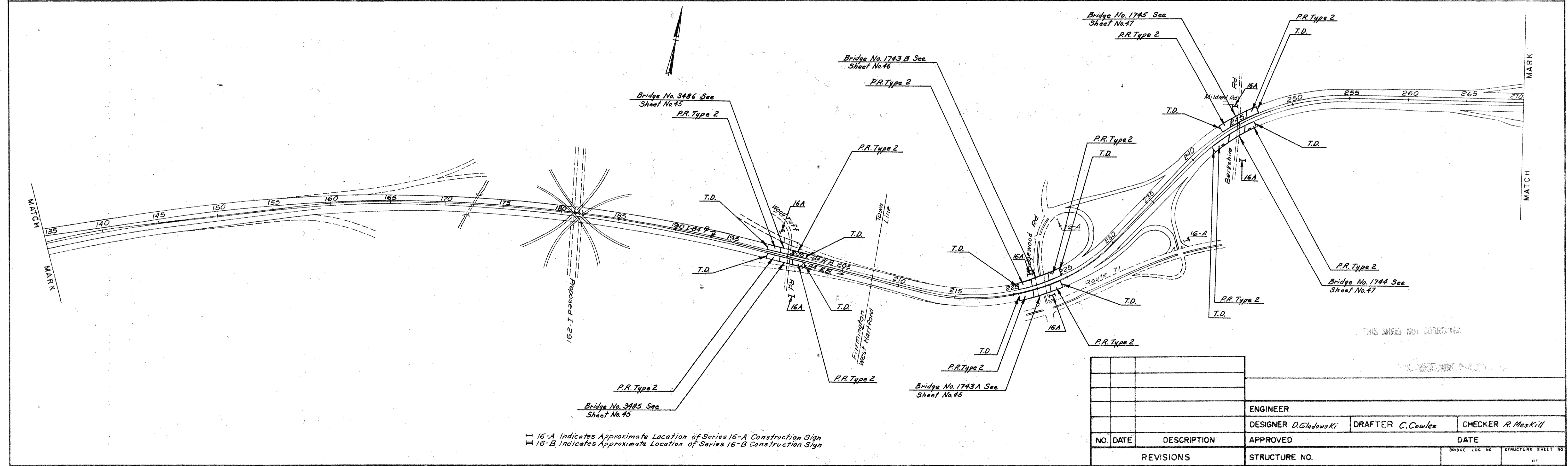
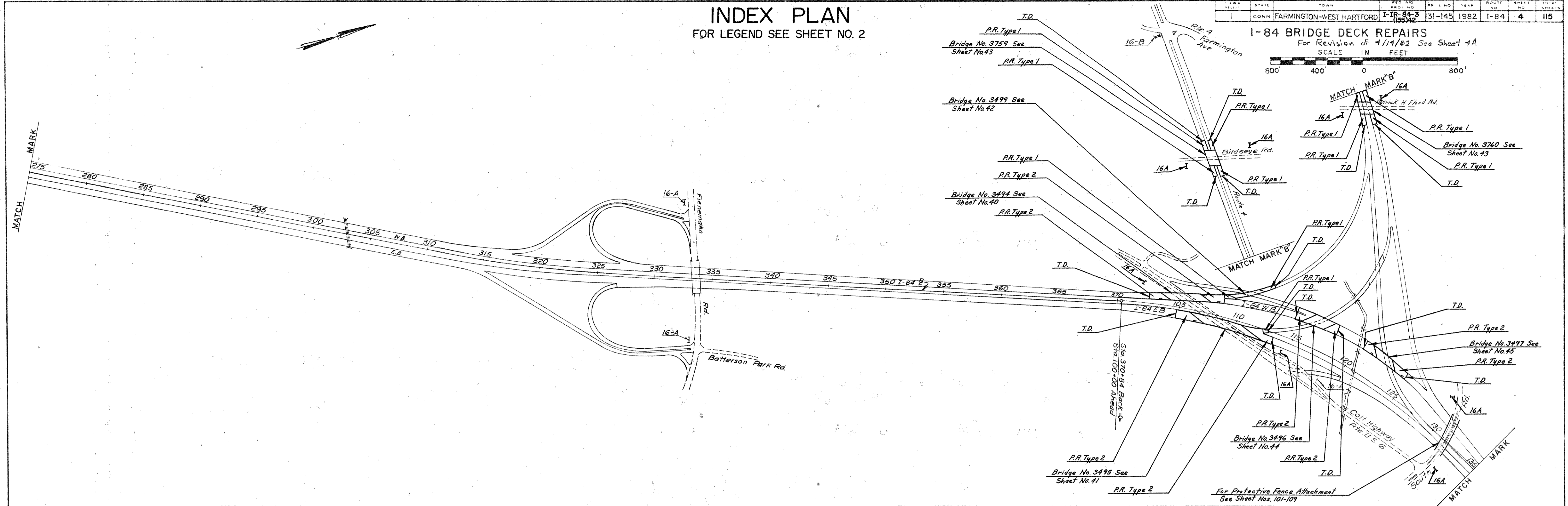

16-A Indicates Approximate Location of Series 16-A Construction Sign
 16-B Indicates Approximate Location of Series 16-B Construction Sign

ENGINEER		DESIGNER D. Gladowski		DRAFTER C. Cowles		CHECKER R. Meskill	
NO.	DATE	DESCRIPTION	APPROVED	DATE			
REVISIONS				STRUCTURE NO.		BRIDGE LOG NO.	STRUCTURE SHEET NO.

THIS SHEET NOT CORRECTED

INDEX PLAN

FOR LEGEND SEE SHEET NO. 2

I-84 BRIDGE DECK REPAIRS

SCALE IN FEET
800' 400' 0' 400' 800'

Revised 4/17/82

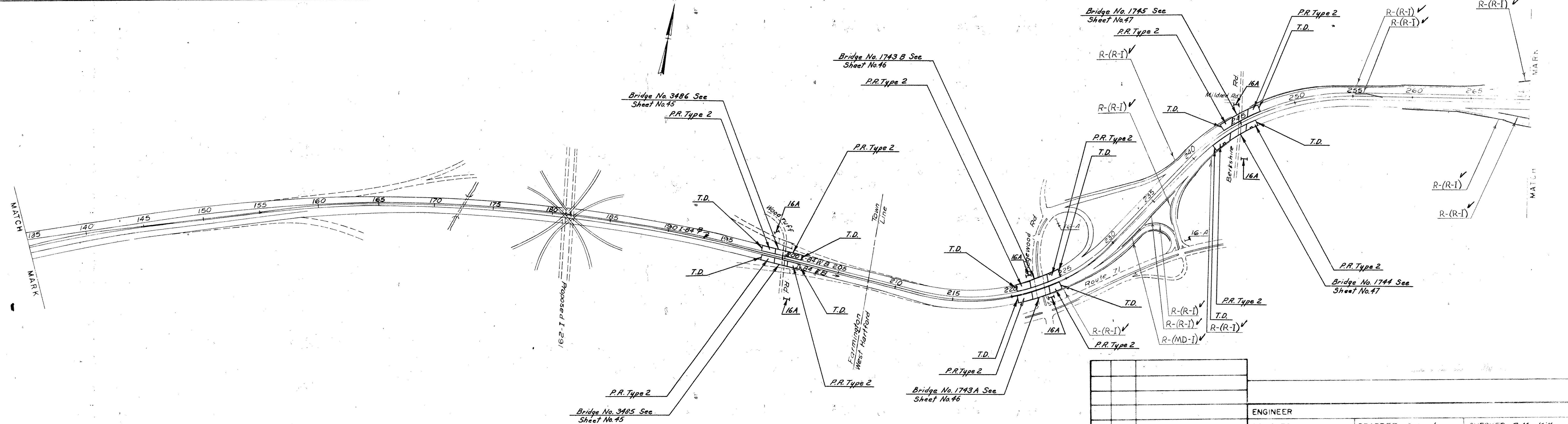
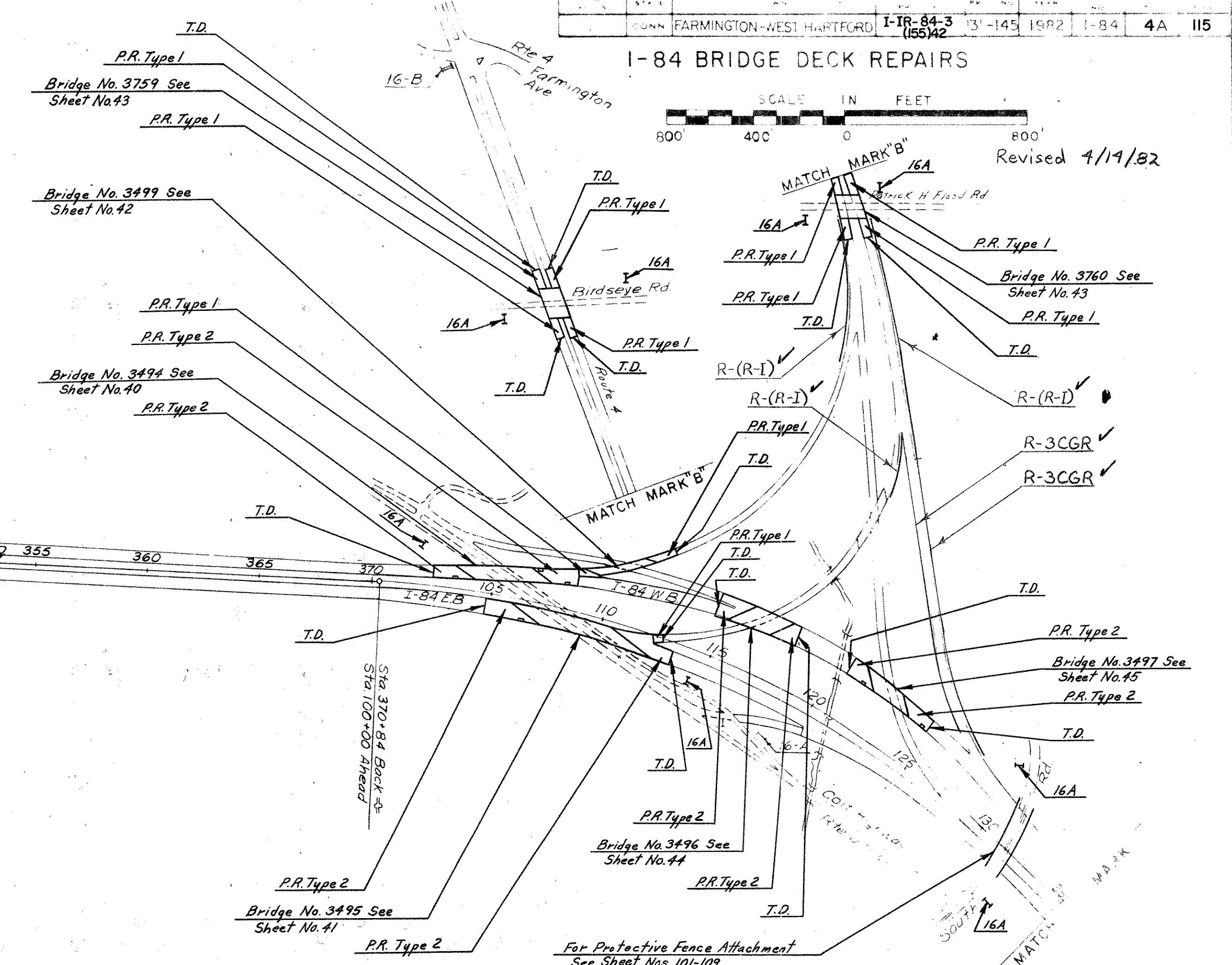
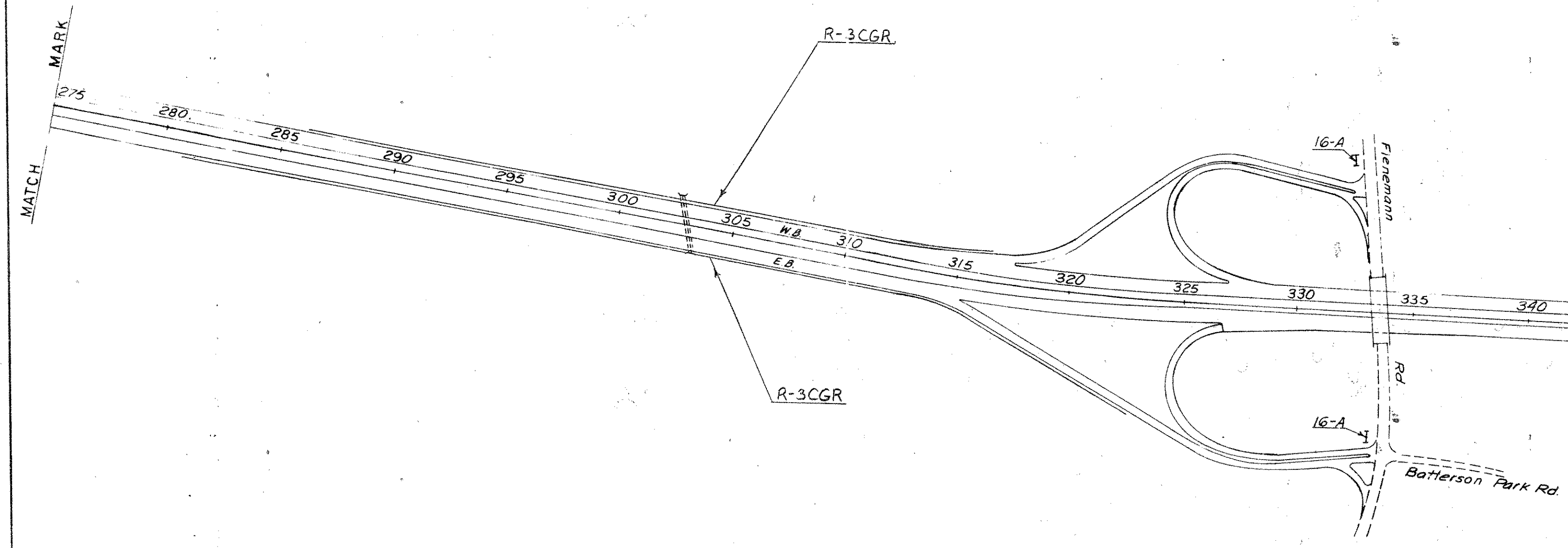

I 16-A Indicates Approximate Location of Series 16-A Construction Sign
 II 16-B Indicates Approximate Location of Series 16-B Construction Sign

		ENGINEER	
		DESIGNER <i>D. Gladuski</i>	DRAFTER <i>C. Cowles</i>
		CHECKER <i>R. Meskill</i>	
NO.	DATE	DESCRIPTION	APPROVED
		REVISIONS	STRUCTURE NO.

INDEX PLAN

FOR LEGEND SEE SHEET NO. 2

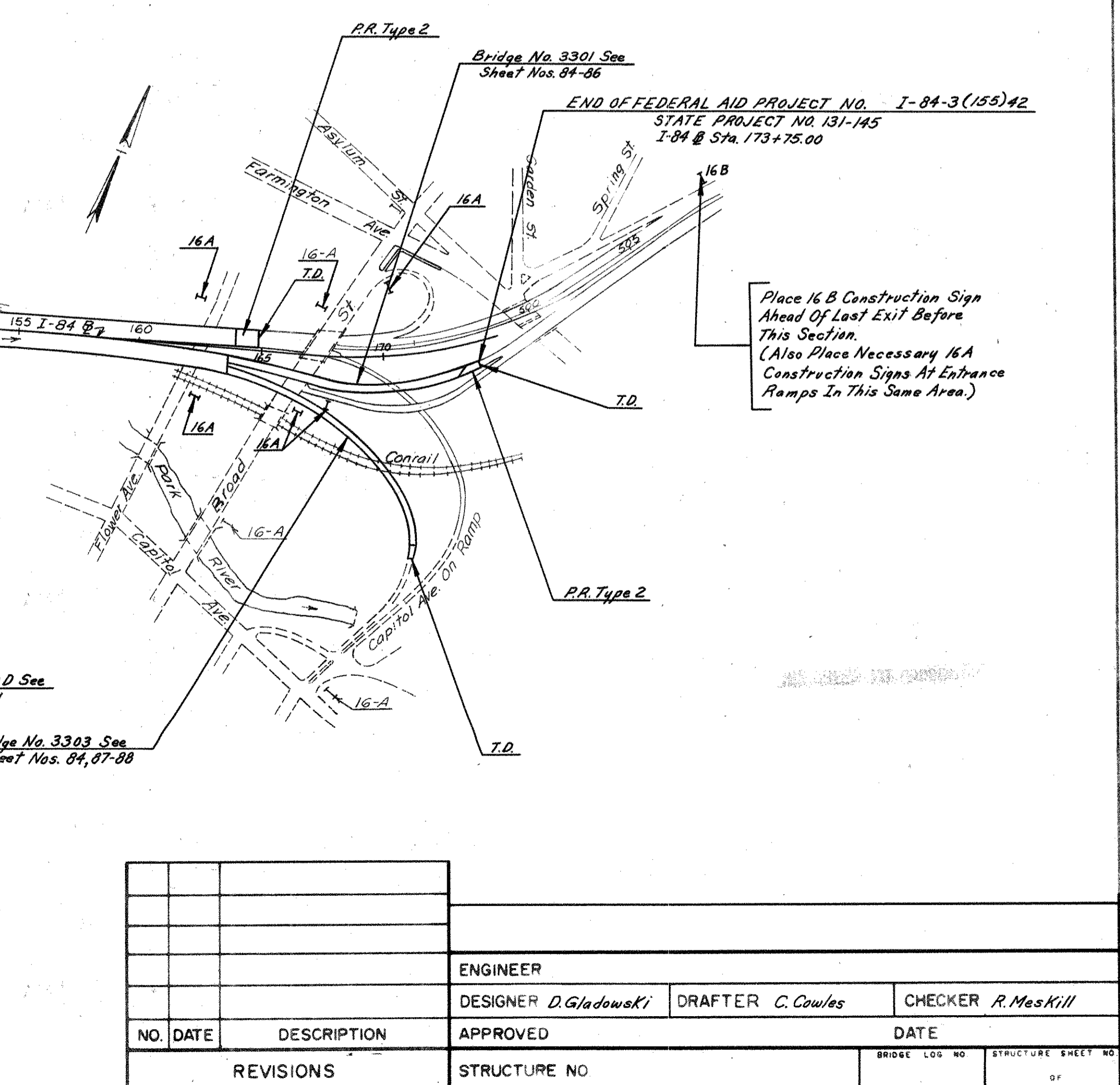
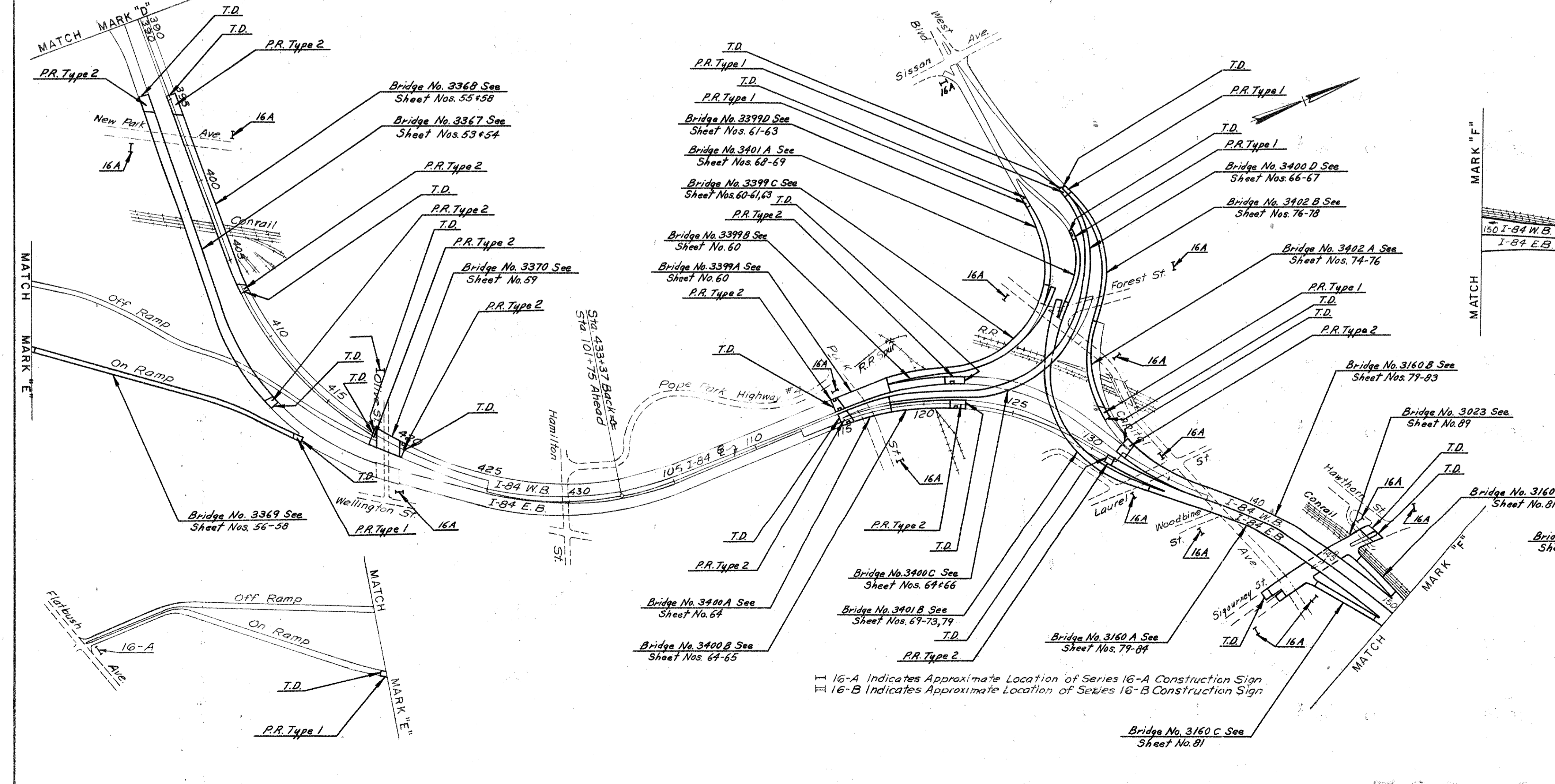
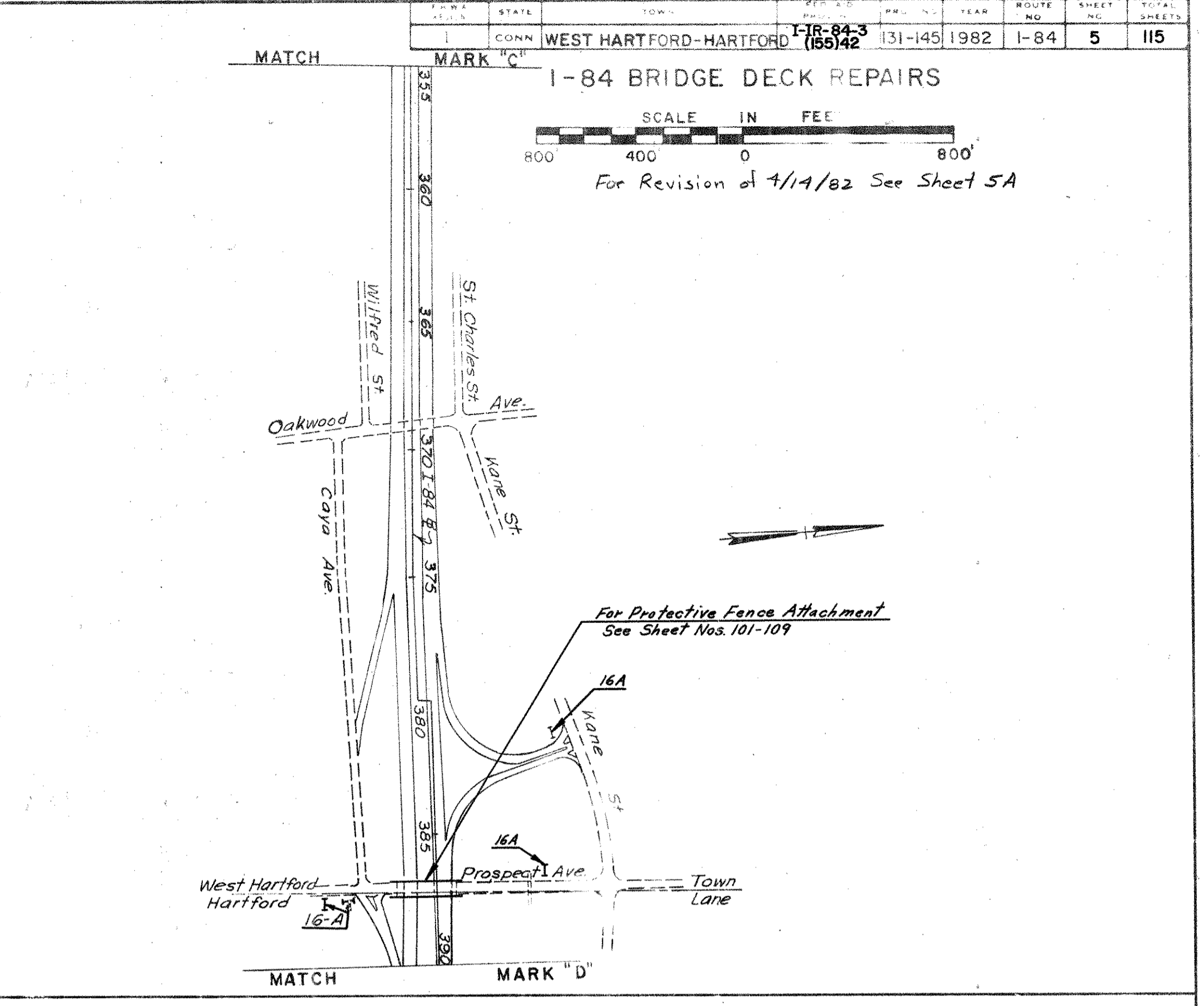
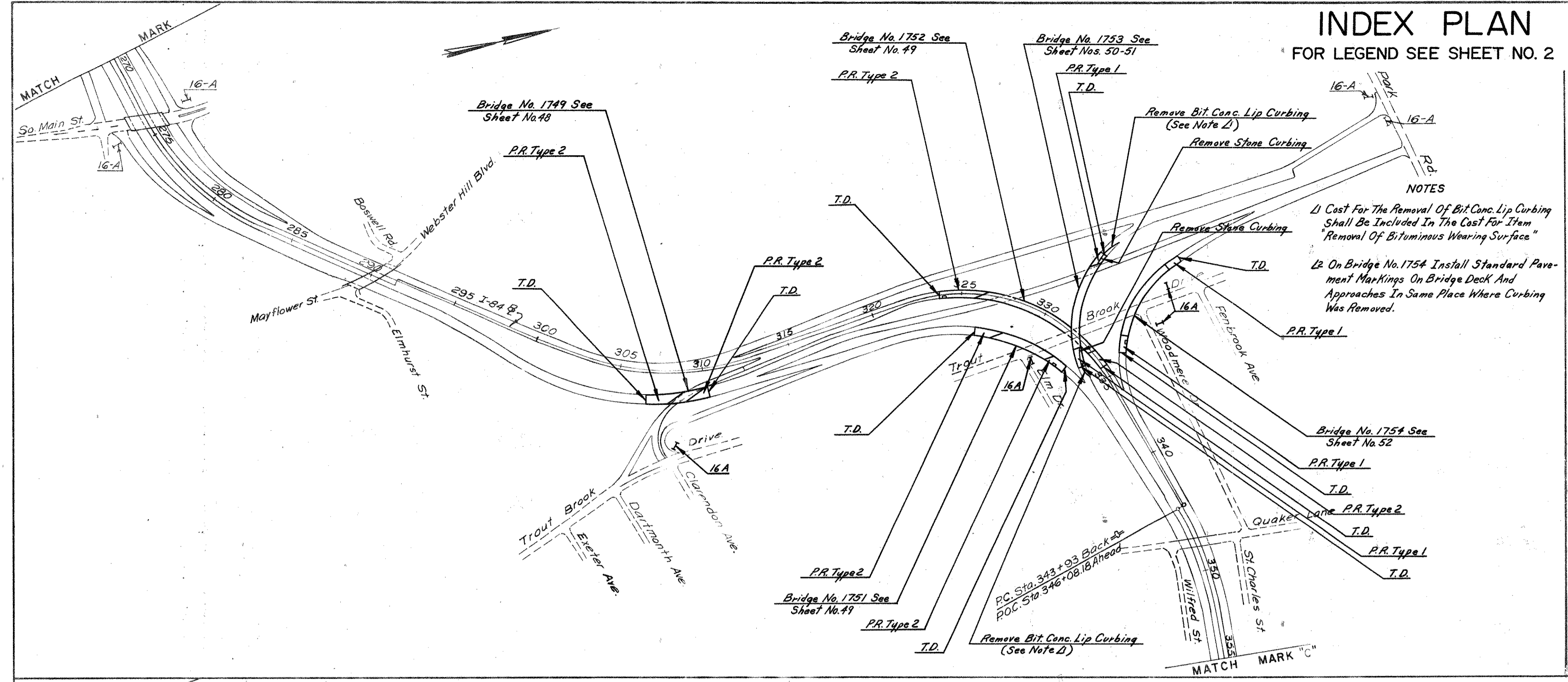
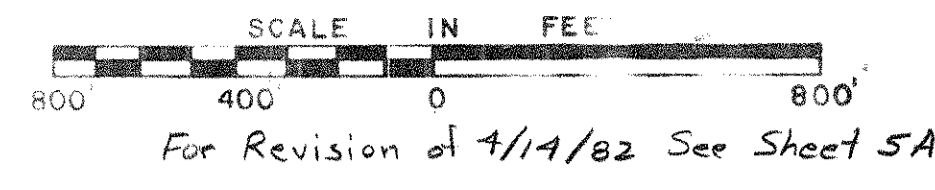

16-A Indicates Approximate Location of Series 16-A Construction Sign
 16-B Indicates Approximate Location of Series 16-B Construction Sign

ENGINEER		DESIGNER <i>D. Gladowski</i>		DRAFTER <i>C. Cowles</i>		CHECKER <i>R. Meskill</i>	
NO.	DATE	DESCRIPTION	APPROVED	DATE			
REVISIONS				STRUCTURE NO.	BRIDGE LOG NO.	STRUCTURE SHEET NO.	OF

INDEX PLAN

FOR LEGEND SEE SHEET NO. 2

SCALE IN FEET
 0 400 800
 Revised 1/14/82

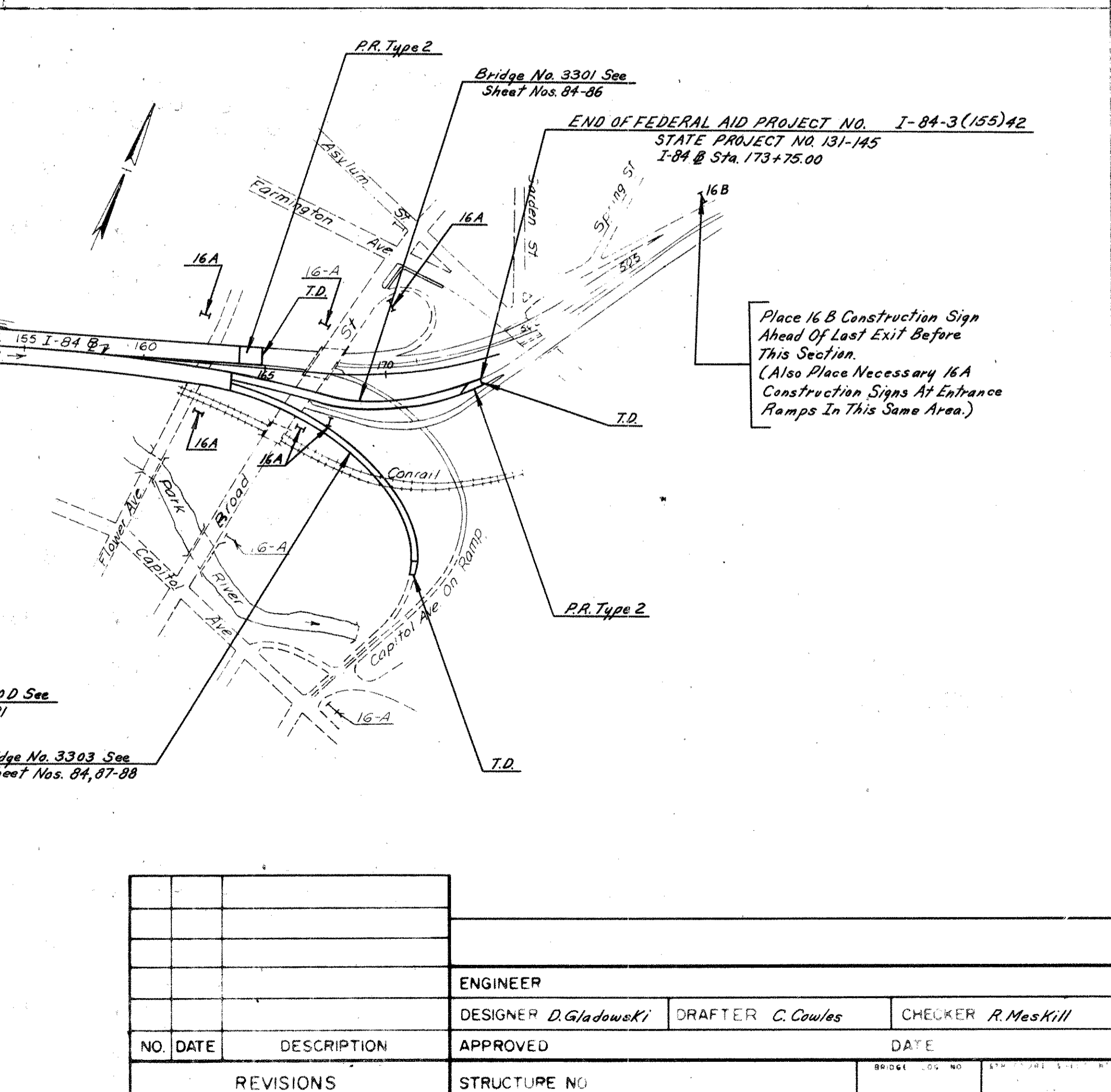
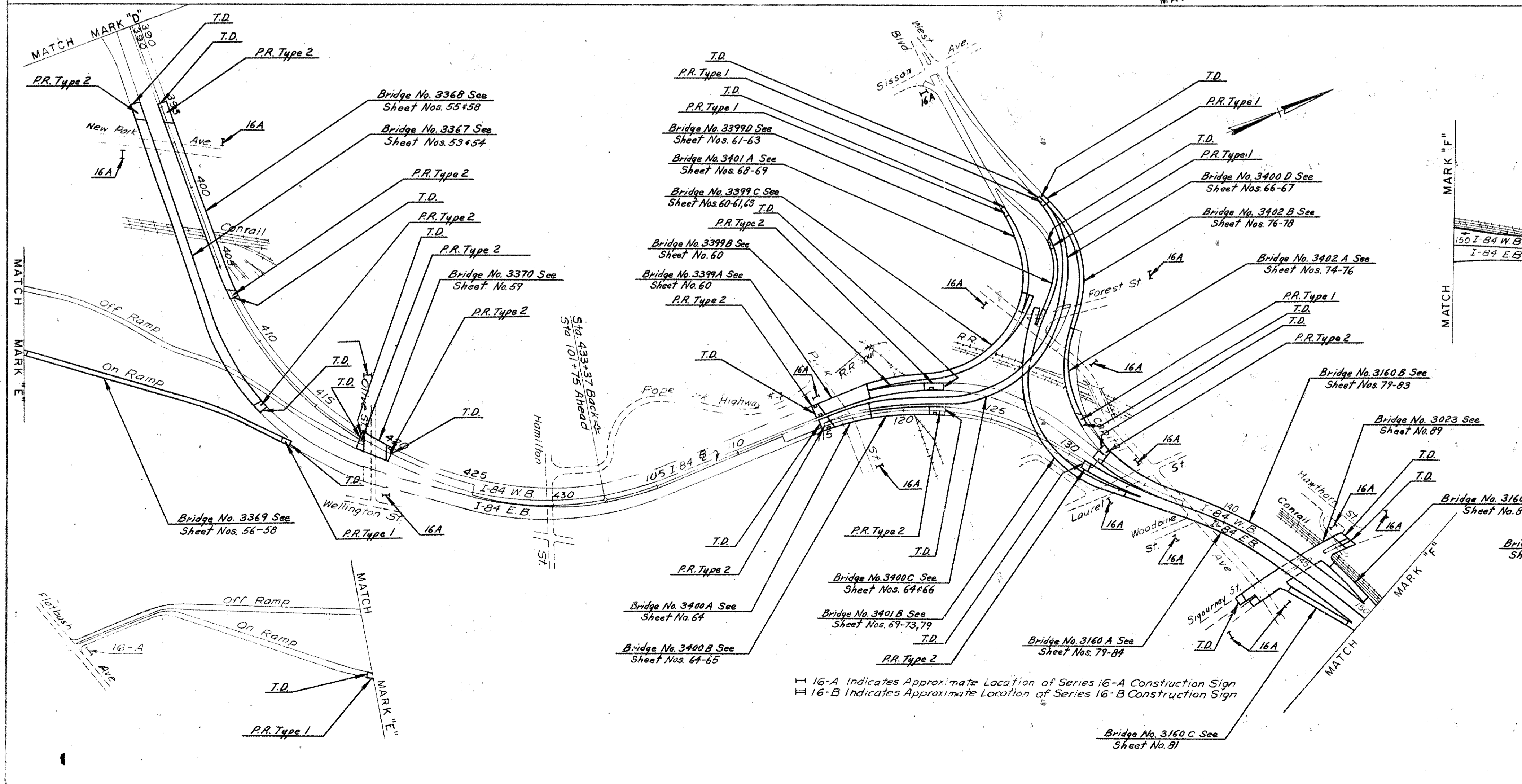
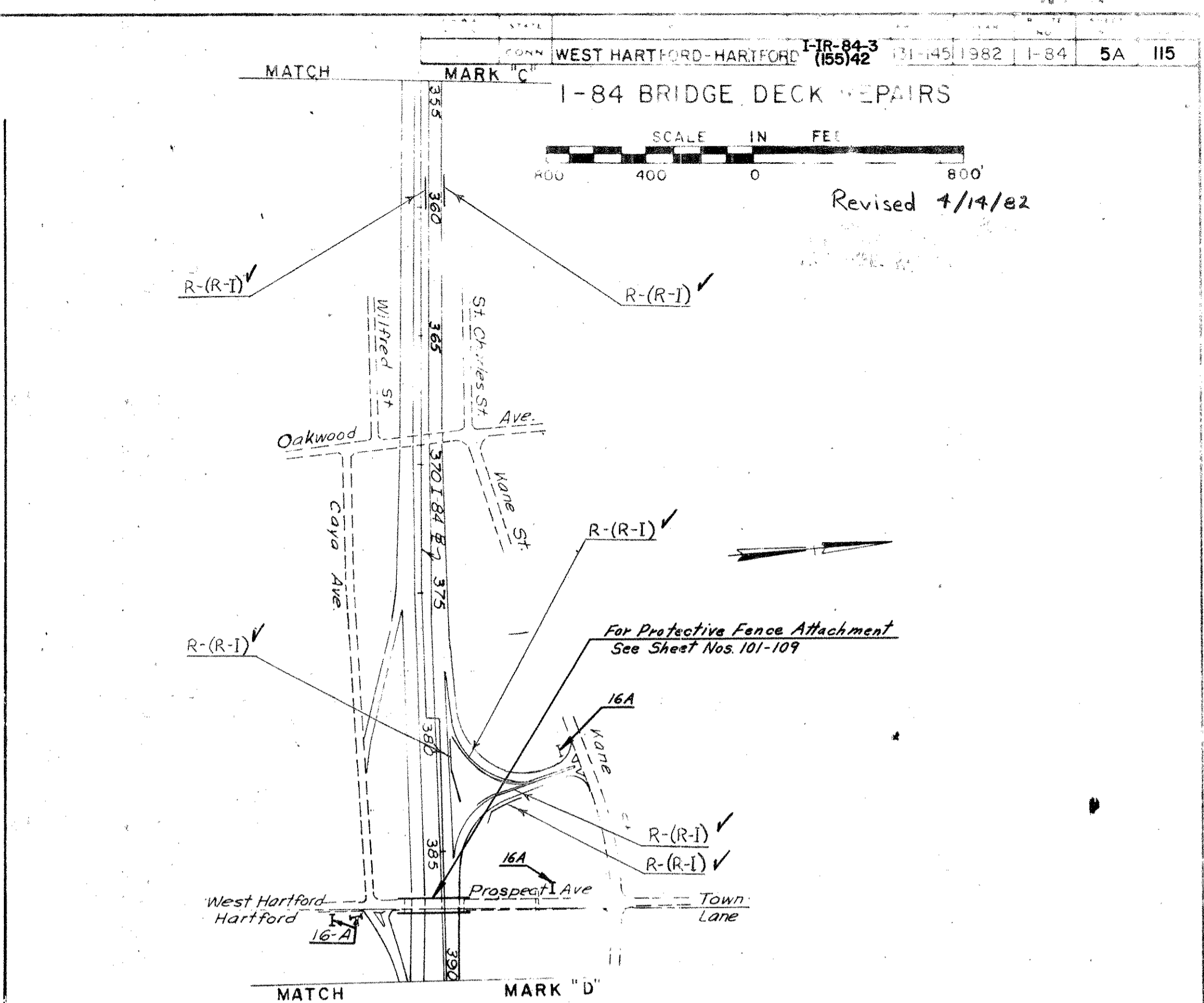
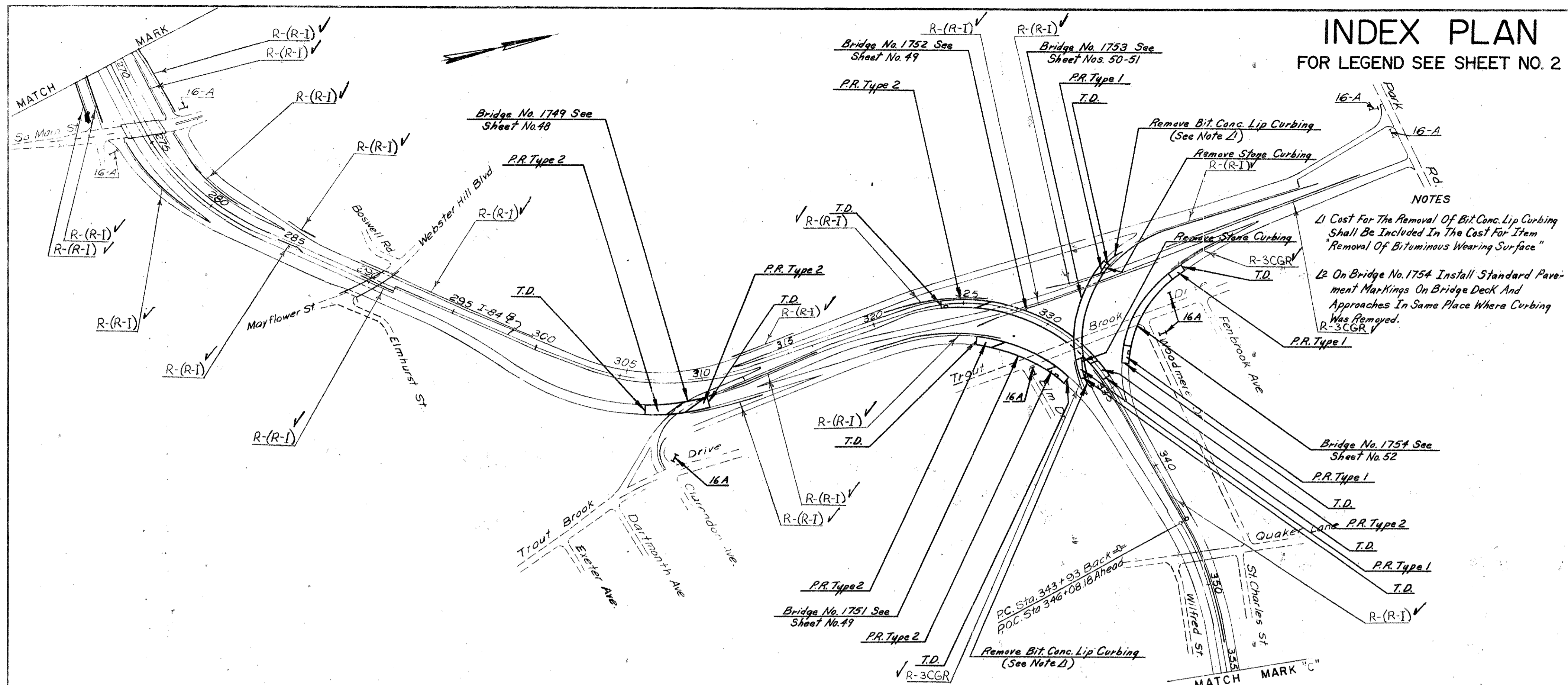

NOTES
 1) Cast For The Removal Of Bit Conc. Lip Curbing Shall Be Included In The Cast For Item "Removal Of Bituminous Wearing Surface"
 2) On Bridge No. 1754 Install Standard Pavement Markings On Bridge Deck And Approaches In Same Place Where Curbing Was Removed.
 R-3CGR ✓

END OF FEDERAL AID PROJECT NO. I-84-3(155)42
 STATE PROJECT NO. 131-145
 I-84 @ Sta. 173+75.00
 Place 16-B Construction Sign Ahead Of Last Exit Before This Section.
 (Also Place Necessary 16-A Construction Signs At Entrance Ramps In This Same Area.)

16-A Indicates Approximate Location of Series 16-A Construction Sign
 16-B Indicates Approximate Location of Series 16-B Construction Sign

ENGINEER		DESIGNER D. Gladowski		DRAFTER C. Cowles		CHECKER R. MasKil	
NO. DATE		DESCRIPTION		APPROVED		DATE	
REVISIONS				STRUCTURE NO.			

THE INFORMATION, INCLUDING ESTIMATED QUANTITIES OF WORK, SHOWN ON THESE SHEETS IS BASED ON LIMITED INVESTIGATIONS BY THE STATE AND IS IN NO WAY WARRANTED TO INDICATE THE TRUE CONDITIONS OR ACTUAL QUANTITIES OR DISTRIBUTION OF QUANTITIES OF WORK WHICH WILL BE REQUIRED.

DETAILED ESTIMATE SHEET

I-84 BRIDGE DECK REPAIRS

Table with columns: B.P.R. REGION NO., STATE, TOWN, FED. AID PROJ. NO., PROJ. NO., YEAR, ROUTE NO., SHEET NO., TOTAL SHEETS. Values include: 1, CONN., SOUTHWINGTON - HARTFORD, I-84-3(155)42, 131-145, 1982, I-84, 6, 115.

FOR THE CONSTRUCTION OF

IN THE TOWNS OF SOUTHWINGTON, PLAINVILLE, NEW BRITAIN, FARMINGTON, WEST HARTFORD AND HARTFORD

FROM STA. 105+30.00 TO STA. 173+75.00 LENGTH FEET: BASE COURSE WIDTH FEET: DEPTH INCHES: SURFACE COURSE 3/4" BIT. CONC. CLASS 14 ON 1/4" TO 2 1/4" BIT. CONC. CLASS 1 WIDTH VARIES FEET: DEPTH INCHES

* BRIDGES TO WHICH PROTECTIVE FENCES ARE TO BE ADDED

THIS SHEET NOT CORRECTED

ROADWAY ITEMS

BRIDGE ITEMS

Main data table with columns for Bridge No., Description, and various material quantities (LF, SY, CY, TON, GAL) for Roadway and Bridge items. Includes rows for Southwington, Plainville, New Britain, Farmington, West Hartford, and Hartford.

DRAFTED 3/7/82 CHECKED 8/10/82

MISCELLANEOUS and UNASSIGNED rows with material quantities.

TOTALS row summarizing all material quantities across all categories.

THE INFORMATION, INCLUDING ESTIMATED QUANTITIES OF WORK, SHOWN ON THESE SHEETS IS BASED ON LIMITED INVESTIGATIONS BY THE STATE AND IS IN NO WAY WARRANTED TO INDICATE THE TRUE CONDITIONS OR ACTUAL QUANTITIES OR DISTRIBUTION OF QUANTITIES OF WORK WHICH WILL BE REQUIRED.

S.P.R. REGION NO.	STATE	TOWN	FED. AID PROJ. NO.	PROJ. NO.	YEAR	ROUTE NO.	SHEET NO.	TOTAL SHEETS
1	CONN.	SOUTHINGTON - HARTFORD	HR-84-3055M2	131-145	1982	1-84	7	115

DETAILED ESTIMATE SHEET

FOR THE CONSTRUCTION OF

1-84 BRIDGE DECK REPAIRS

IN THE TOWNS OF SOUTHINGTON, PLAINVILLE, NEW BRITAIN, FARMINGTON, WEST HARTFORD AND HARTFORD

FROM STA. 105+30.00 TO STA. 173+75.00 LENGTH FEET: BASE COURSE WIDTH FEET: DEPTH INCHES: SURFACE COURSE 3/4" BIT. CONC. CLASS 14 ON 1 3/4" TO 2 1/4" BIT. CONC. CLASS 1 WIDTH VARIES FEET: DEPTH INCHES

THIS SHEET NOT CONNECTED

MISCELLANEOUS AND TRAFFIC ITEMS

LOCATION	CONSTRUCTION FIELD OFFICE (TYPE A)	MAINTENANCE AND PROTECTION OF TRAFFIC	SAFETY PATROL SERVICE	MOBILIZATION AND DEMOBILIZATION	CONSTRUCTION STAKING	TRAFFICMEN	TRAFFICMEN (STATE POLICE OFFICERS)	TRAFFICMEN (TOWN (CITY) POLICE OFFICERS)	TRAFFIC CONE	TRAFFIC DRUM	BARRICADE WARNING LIGHTS - LOW INTENSITY	BARRICADE WARNING LIGHTS - HIGH INTENSITY	BARRICADE WARNING LIGHTS - STEADY BURN	HIGH MOUNTED INTERNALLY ILLUMINATED FLASHING ARROW	HIGH MOUNTED INTERNALLY ILLUMINATED VARIABLE MESSAGE SIGN	PAINTED PAVEMENT MARKINGS - 4" YELLOW	PAINTED PAVEMENT MARKINGS - 4" WHITE	CONSTRUCTION SIGNS ENCAPSULATED LENS REFLECTIVE SHEETING	4" WHITE CLASS 1 PREFORMED PLASTIC PAVEMENT MARKINGS	4" YELLOW CLASS 1 PREFORMED PLASTIC PAVEMENT MARKINGS	8" WHITE CLASS 1 PREFORMED PLASTIC PAVEMENT MARKINGS	12" WHITE CLASS 1 PREFORMED PLASTIC PAVEMENT MARKINGS	PREFORMED PLASTIC PAVEMENT MARKINGS SYMBOLS & LEGEND CLASS 1
	MO	LS	HR	LS	LS	HR	HR	HR	EA	DAY	DAY	DAY	DAY	DAY	DAY	LF	LF	SF	LF	LF	LF	LF	SF
1-84	37	LS	3000	LS	LS	800	2500	200	200	5000	10000	8000	10000	4000	500	85000	130000	3608	70200	47500	5200	260	350
UNASSIGNED																		182					
TOTALS	37	LS	3000	LS	LS	800	2500	200	200	5000	10000	8000	10000	4000	500	85000	130000	3790	70200	47500	5200	260	350

STA. TO STA.																							
--------------	--	--	--	--	--	--	--	--	--	--	--	--	--	--	--	--	--	--	--	--	--	--	--

TOTALS																							
--------	--	--	--	--	--	--	--	--	--	--	--	--	--	--	--	--	--	--	--	--	--	--	--

BY DATE
PREPARED
DRAFTED
CHECKED

F.H.W.A. REGION NO.	STATE	TOWN	FED. AID PROJ. NO.	PROJ. NO.	YEAR	ROUTE NO.	SHEET NO.	TOTAL SHEETS
1	CONN.	SOUTHINGTON - HARTFORD	I-19-84-3 15842	131-145	1982	I-84	8	115

MISCELLANEOUS DETAILS

NOT TO SCALE

I-84 BRIDGE DECK REPAIRS

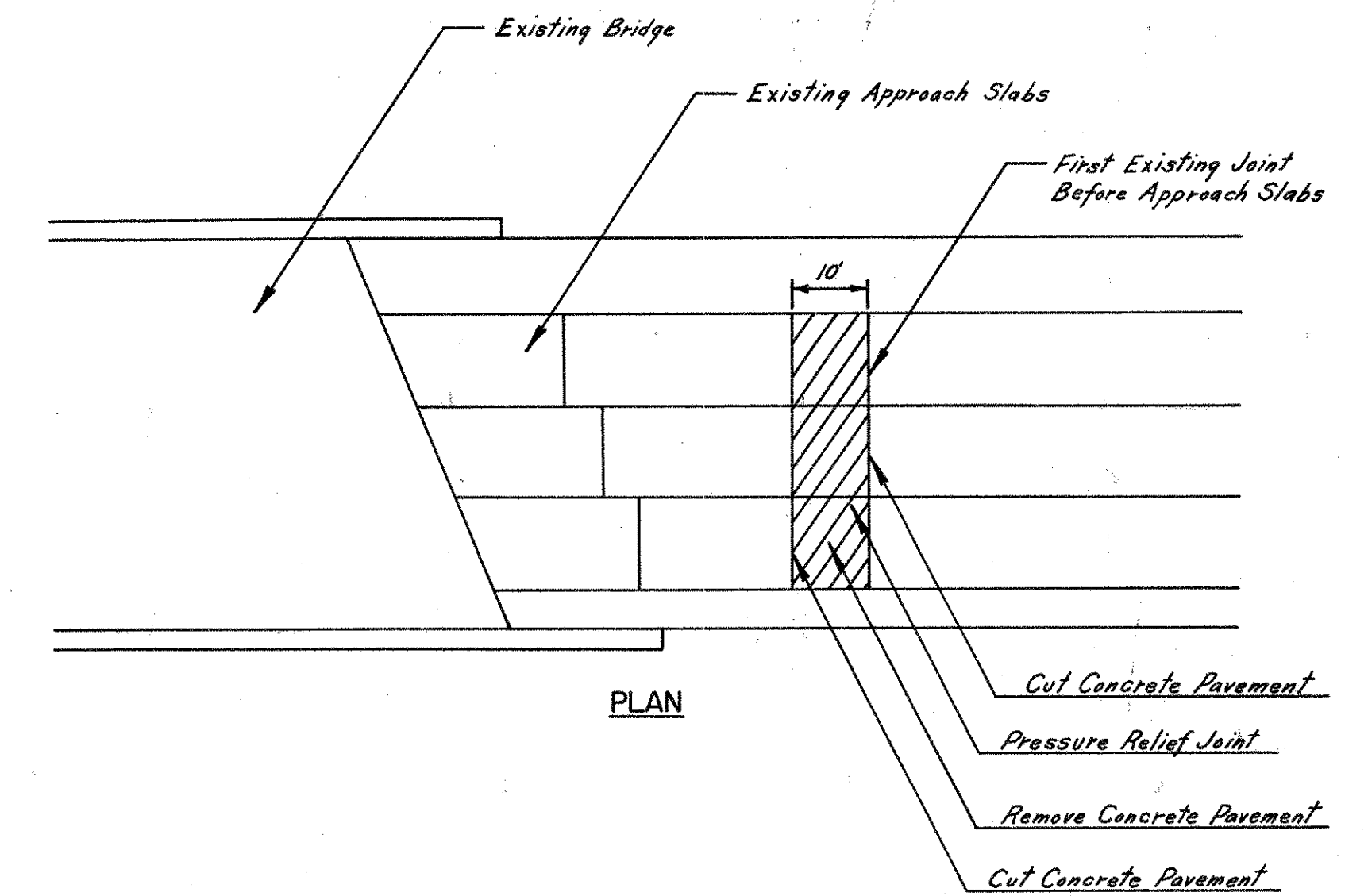
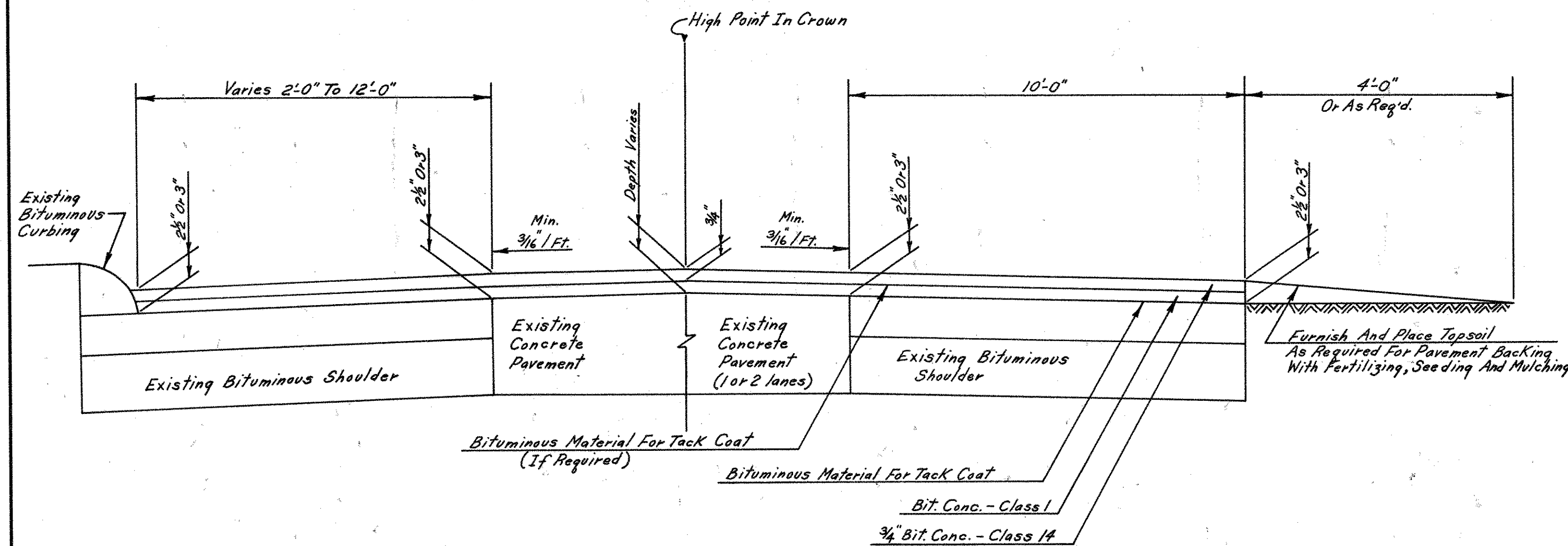

PRESSURE RELIEF JOINT

TRANSVERSE PAVEMENT RESURFACING DETAIL (TYPICAL MAINLINE)

- Notes
1. For Location Of Resurfacing Depths - See Plans
 2. For Ramps And Turning Roadways Details - See Same Sheet
 3. Where Roadway Is Banked, A Constant Depth Of Resurfacing Shall Be Maintained - With A Minimum Cross Slope Of 3/16" / Ft.

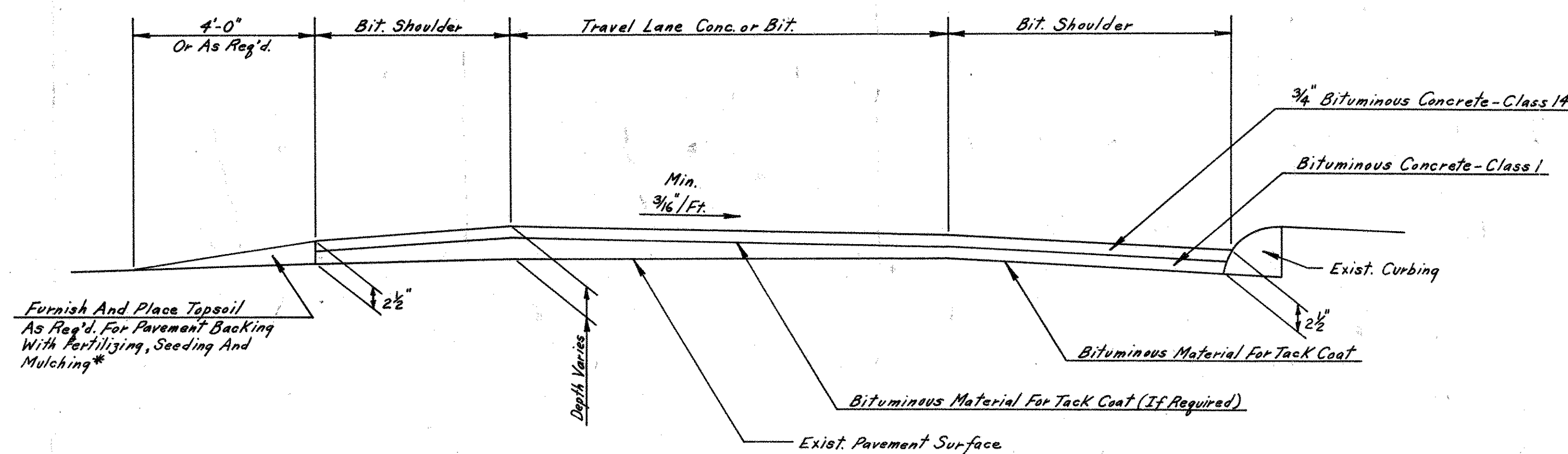

TRANSVERSE PAVEMENT RESURFACING DETAIL (TYPICAL RAMP OR TURNING ROADWAY)

- Note:
- Where Roadway Is Banked, A Constant Depth Of Resurfacing Shall Be Maintained - With A Minimum Cross Slope Of 3/16" / Ft.

* Place Gravel Fill In Areas With Railing

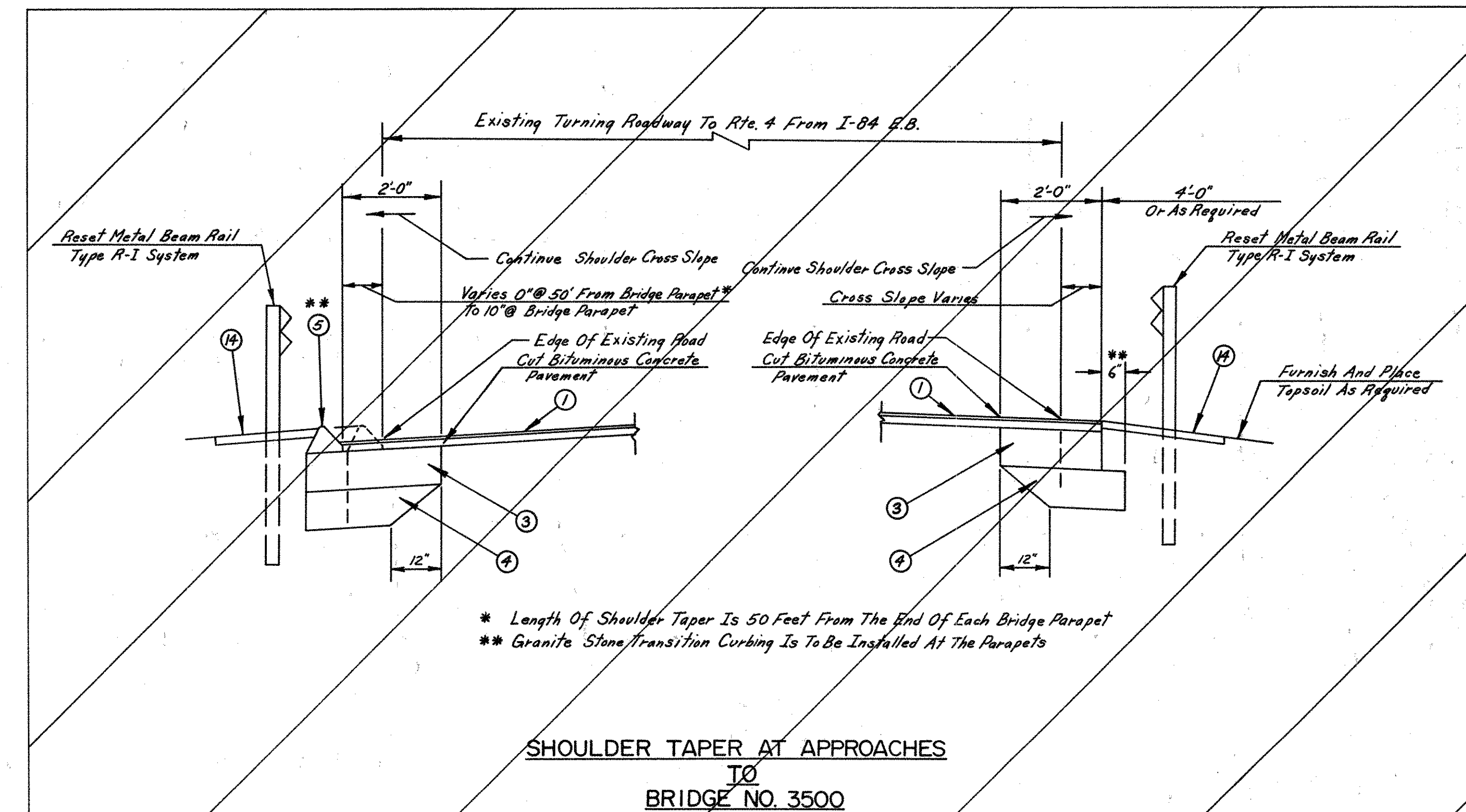

SHOULDER TAPER AT APPROACHES TO BRIDGE NO. 3500

REVISIONS			
NO.	DATE	DESCRIPTION	REV. SHEET NO.

PUB. ROAD DIV. NO.	STATE	TOWN	FED. AID PROJ. NO.	PROJ. NO.	YEAR	ROUTE NO.	SHEET NO.	TOTAL SHEETS
1	CONN.	SOUTHINGTON - HARTFORD	1-18-84-3 (15342)	131-145	1982	1-84	9	115

MISCELLANEOUS DETAILS

NOT TO SCALE

I-84 BRIDGE DECK REPAIRS

DATE	CHECKED BY	DATE	BY

Checked	
Planned	
Traced	
Designed	
New Const. Noted	
Top. Field Chk. Noted	

PLAN	
NOTEBOOK NO.	

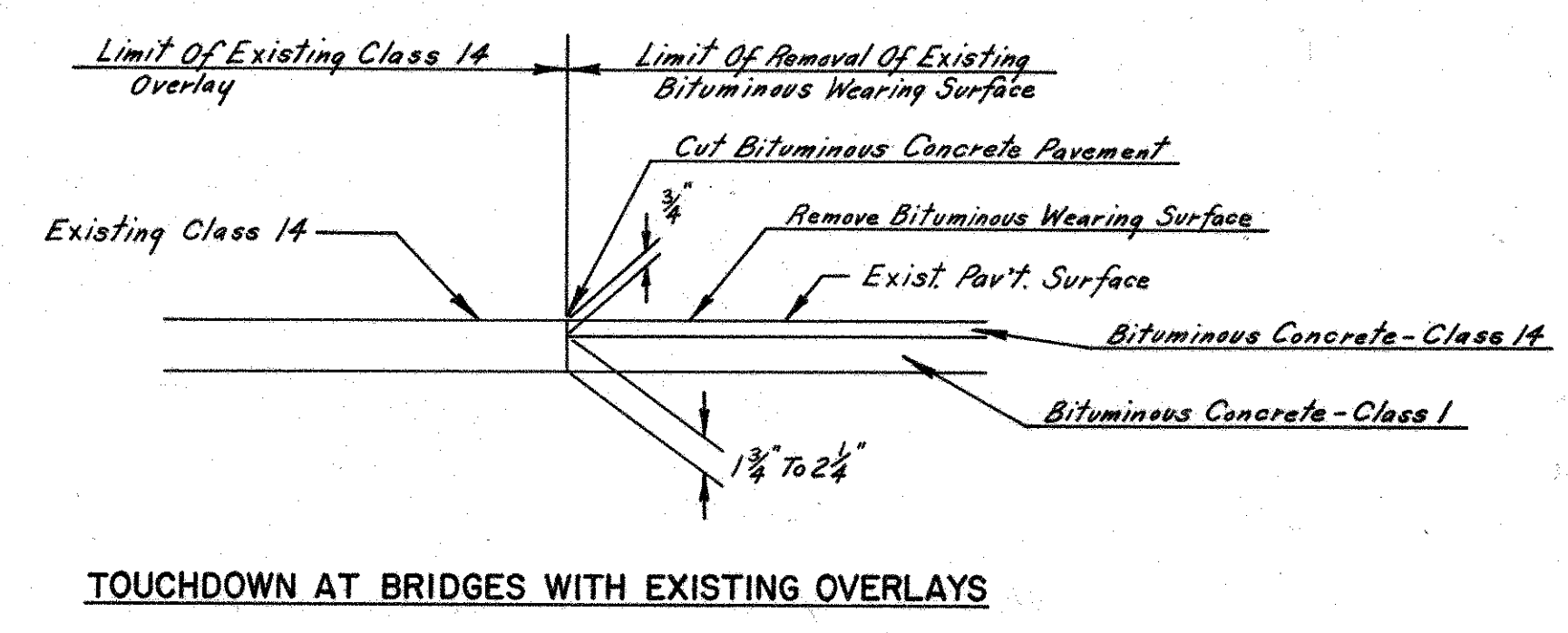

TOUCHDOWN AT BRIDGES WITH EXISTING OVERLAYS

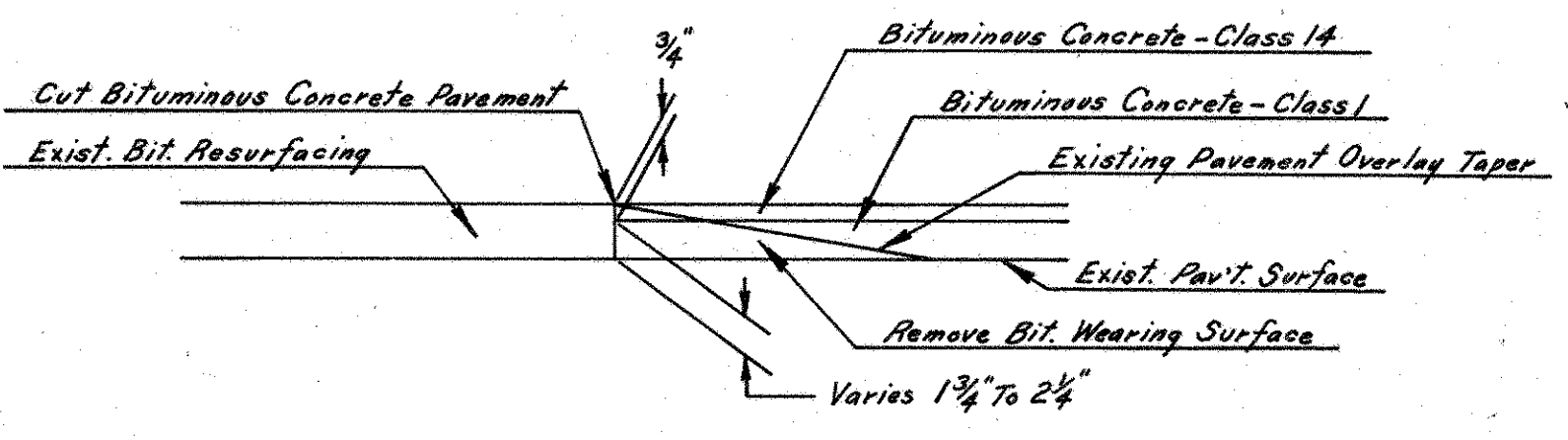

TOUCHDOWN AT EXISTING RESURFACED PAVEMENT

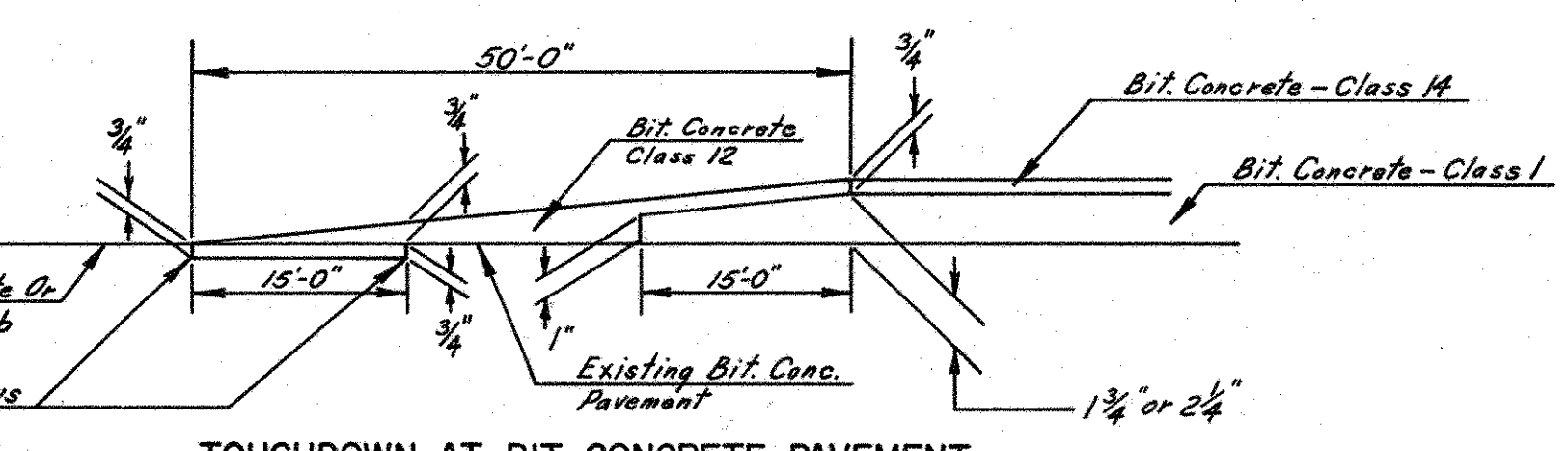

TOUCHDOWN AT BIT. CONCRETE PAVEMENT

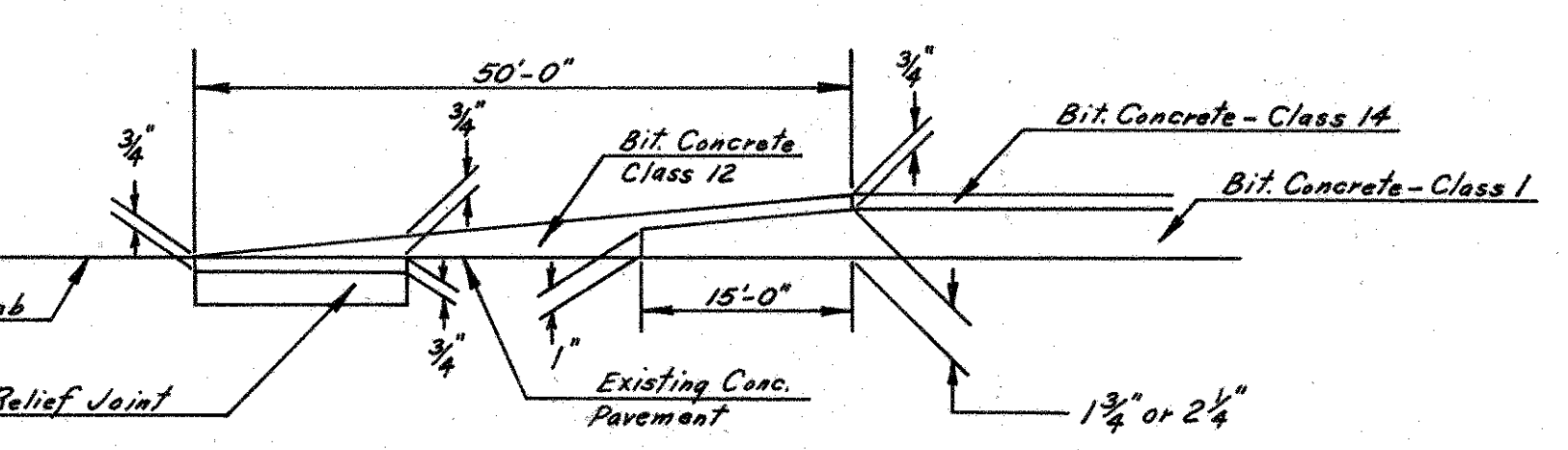

TOUCHDOWN AT PRESSURE RELIEF JOINT

DETAILS FOR MATCHING EXISTING PAVEMENT

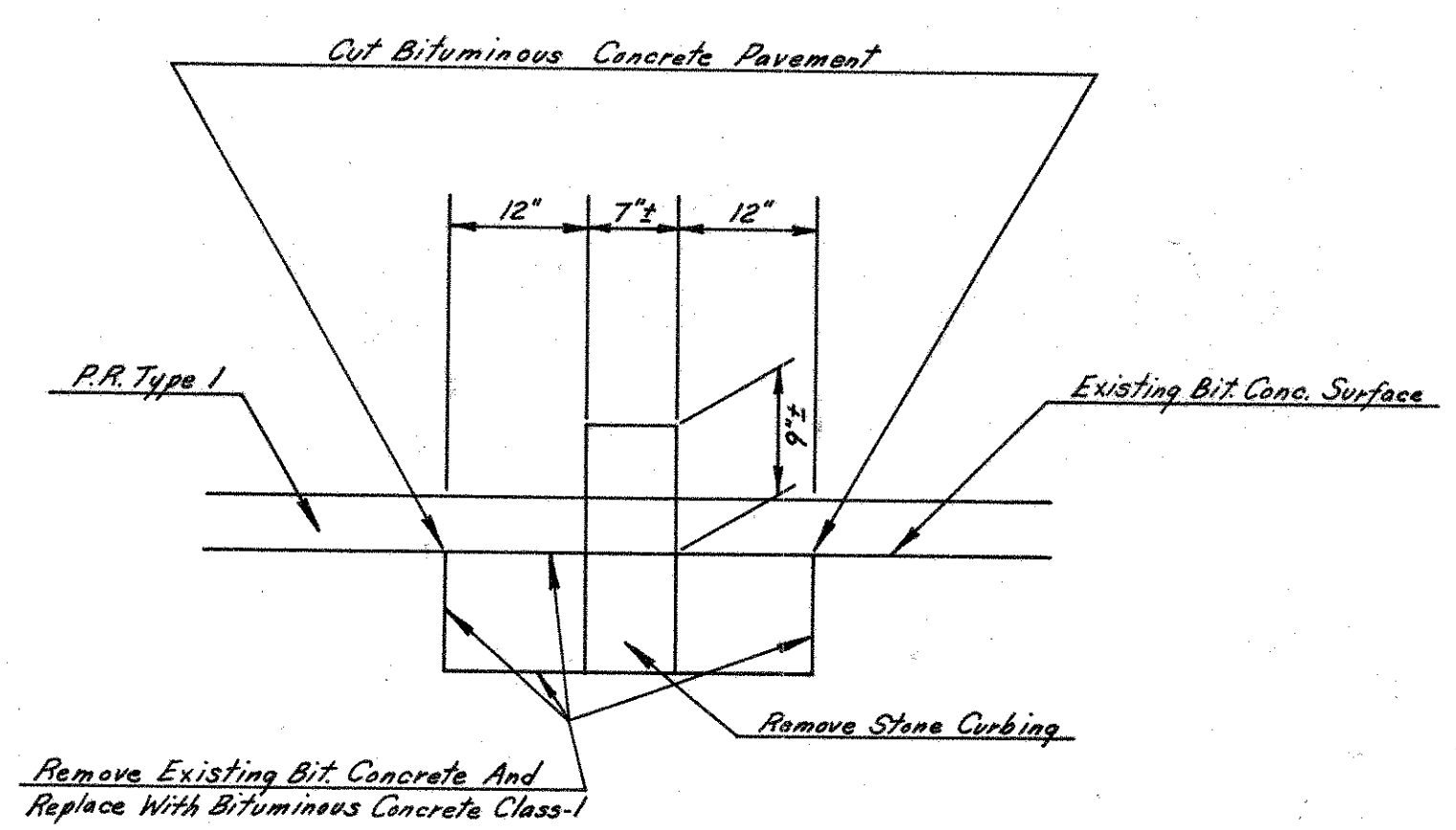

ELEVATION

DETAIL FOR REMOVE STONE CURBING AT APPROACHES TO BRIDGE NO. 1753 IN WEST HARTFORD

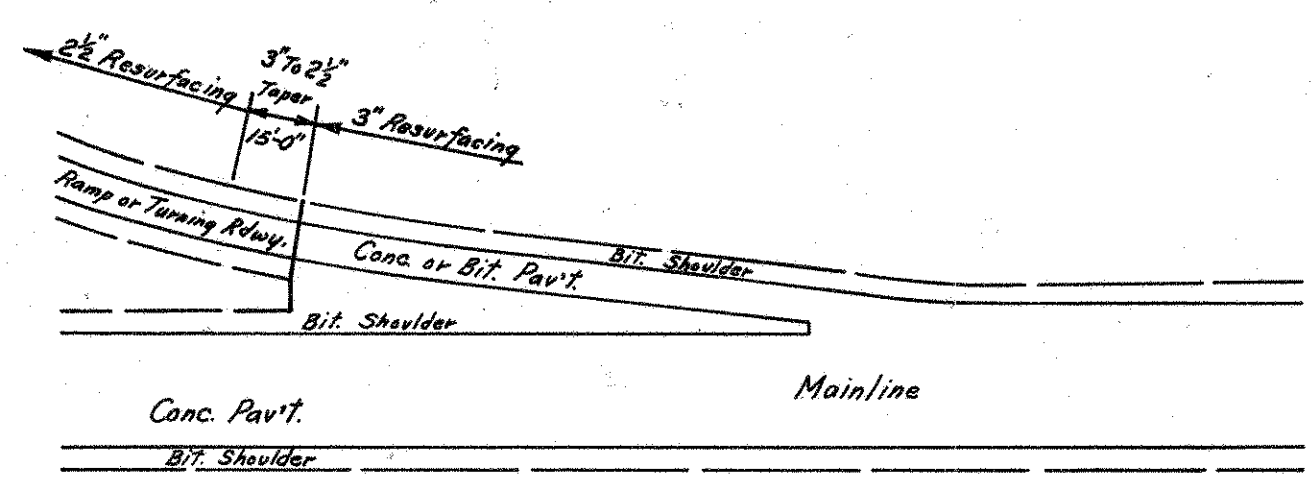

PLAN

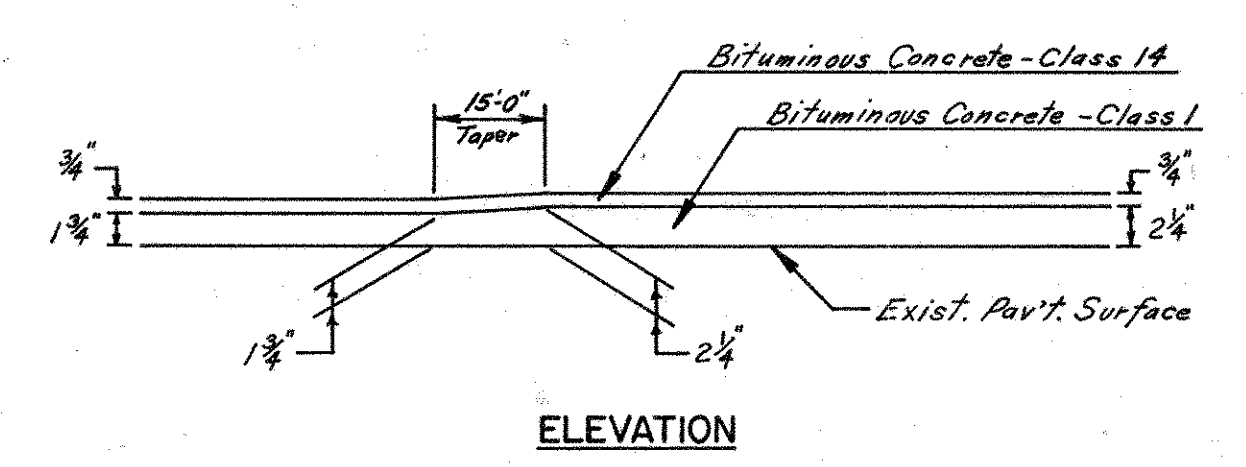

ELEVATION

DETAILS SHOWING TRANSITION FOR RAMP OR TURNING ROADWAY RESURFACING DEPTHS

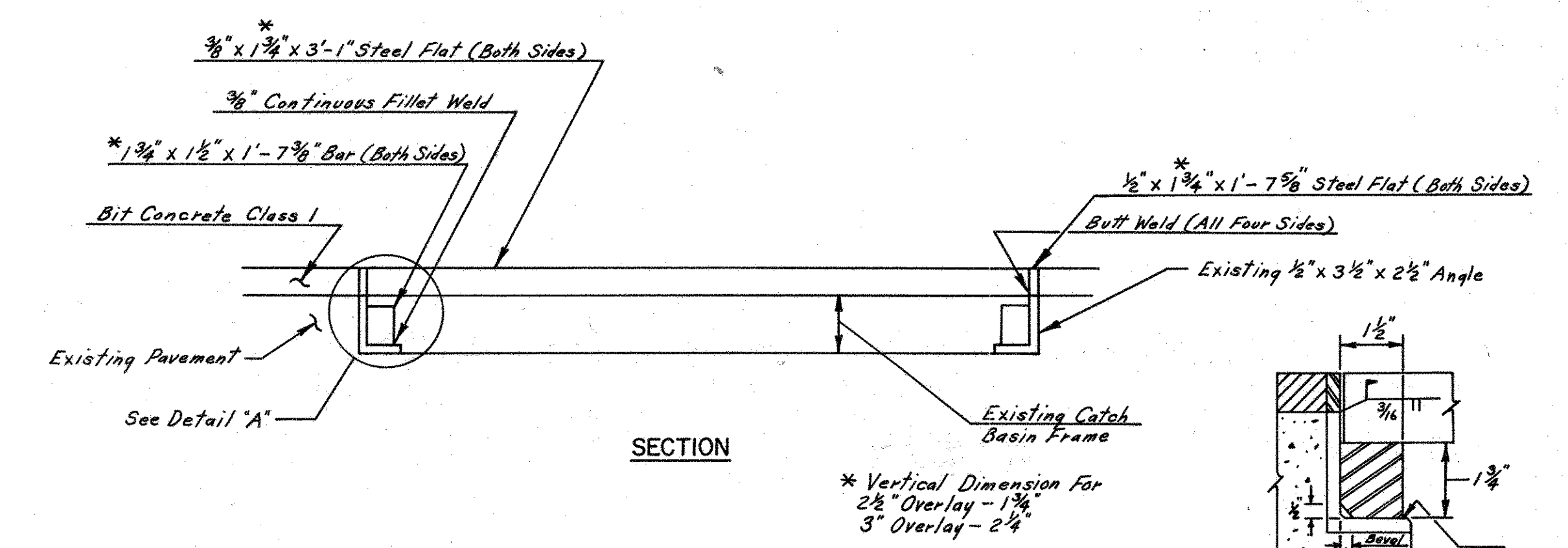

SECTION

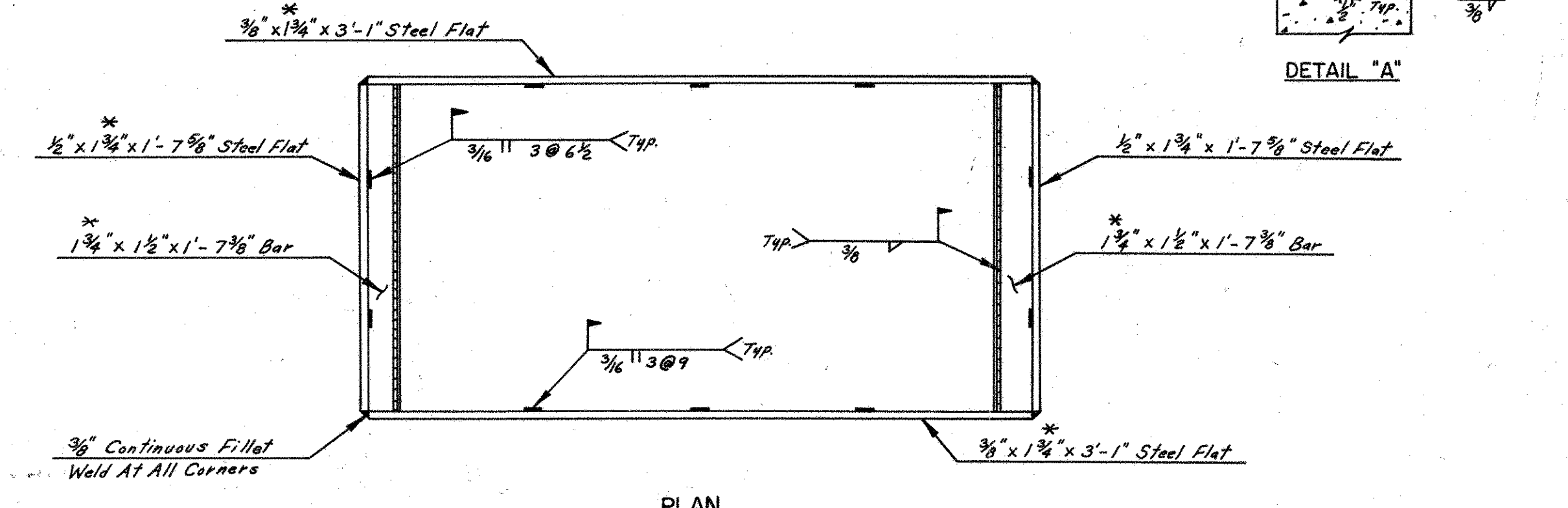

PLAN

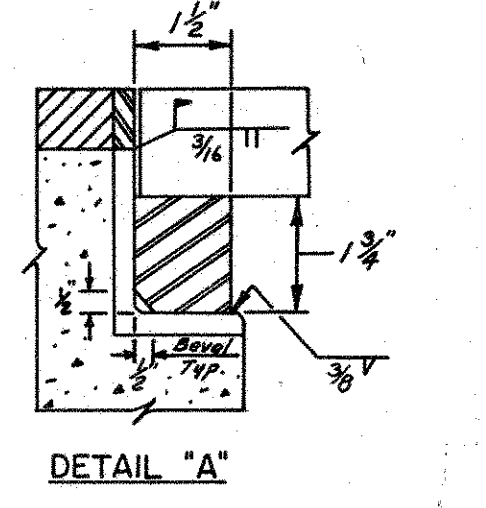

DETAIL "A"

Steel - All Steel To Be Structural Grade Conforming To A.S.T.M. Des. A-588, Or A-283 Of Latest Issue, Grade B, Or Better, Except In The Chemical Composition Of Steel, The 0.20% Of Copper May Be Omitted.

Painting - All Exposed Steel Shall Be Painted One Shop Coat Of Red Lead Paint Conforming To Standard Specifications In Addition All Areas So Painted Shall Be Given A Field Coat Of R-C2 Asphalt Or SS-1 Emulsion.

DETAIL FOR "RAISE CATCH BASIN GRATE"

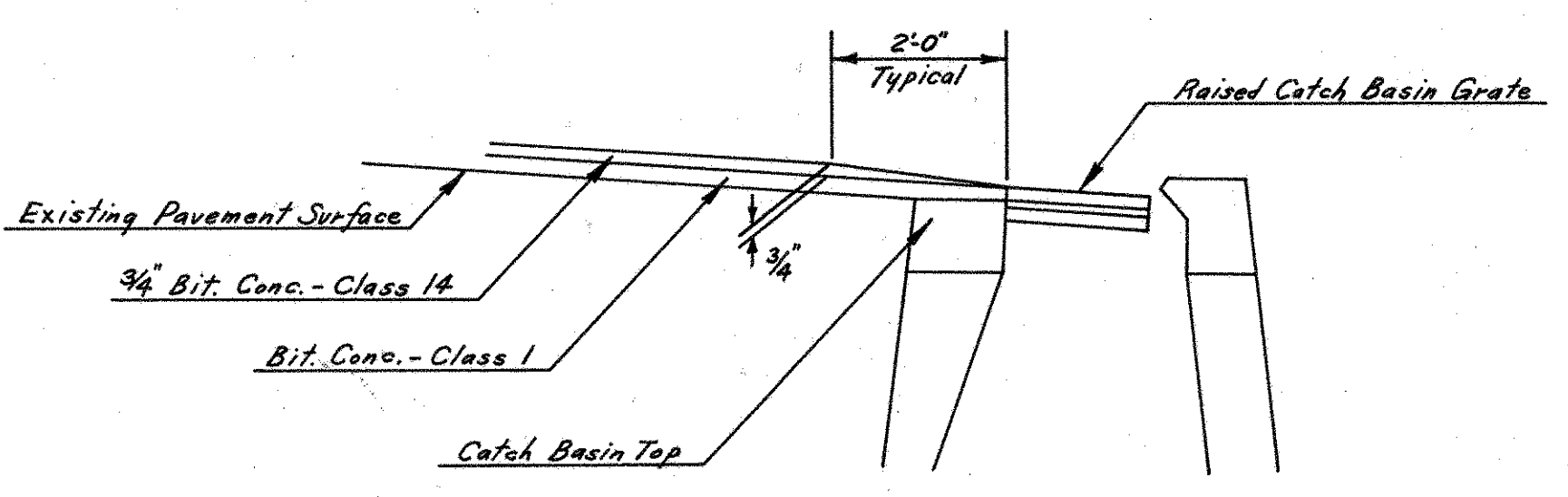

RESURFACING TREATMENT AT CATCH BASINS

REVISIONS			
NO.	DATE	DESCRIPTION	REV. SHEET NO.

F.H.W.A. REGION NO.	STATE	TOWN	FED. AID PROJ. NO.	PROJ. NO.	YEAR	ROUTE NO.	SHEET NO.	TOTAL SHEETS
1	CONN.	HARTFORD	I-R-84-3(55)42	31-45	1982	1-84	10	115

I-84 BRIDGE DECK REPAIRS

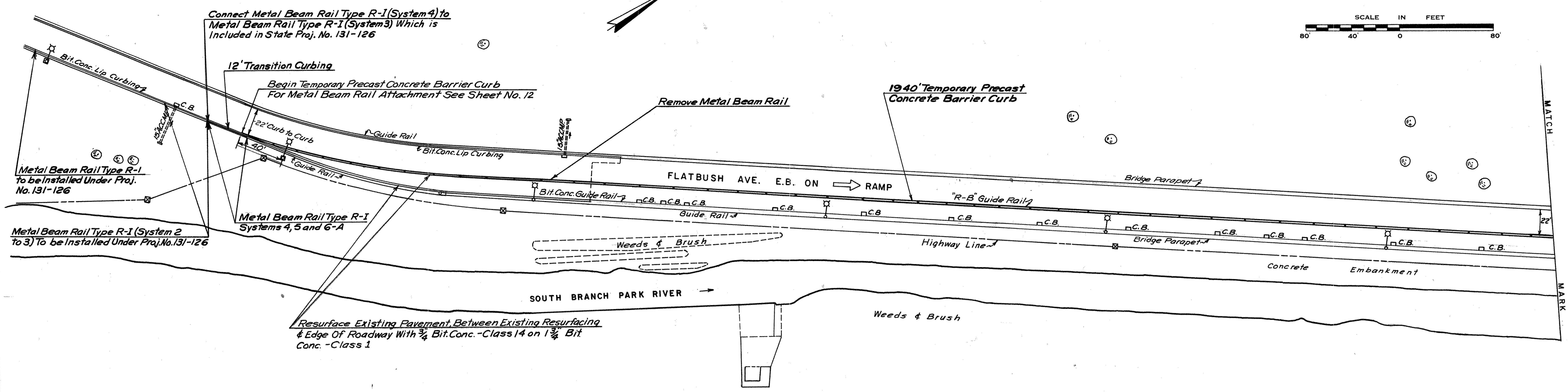
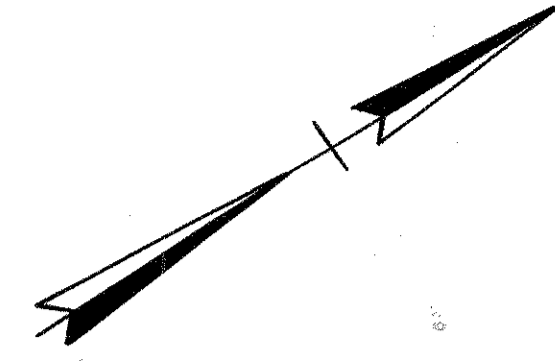
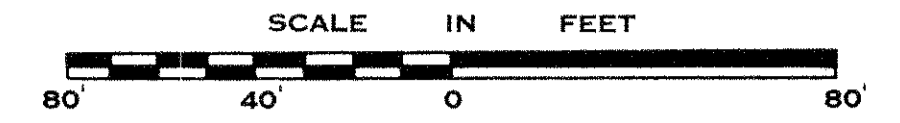

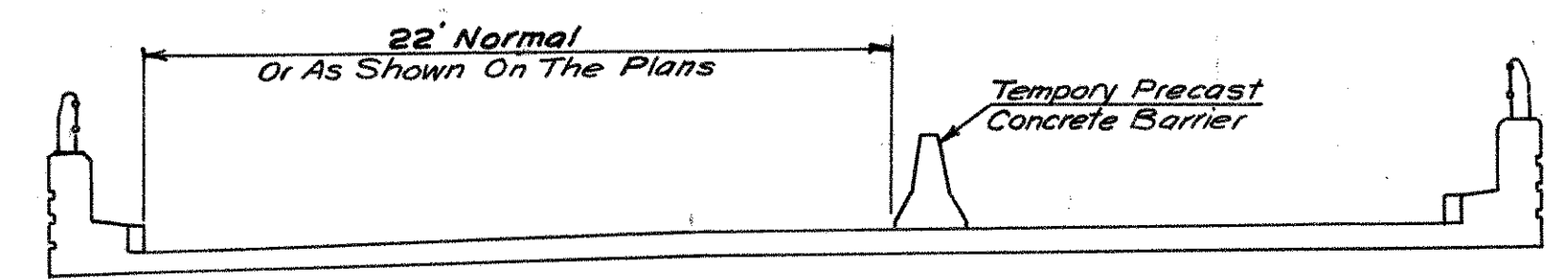
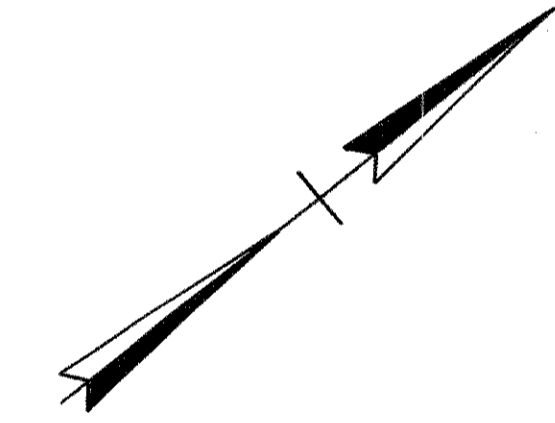
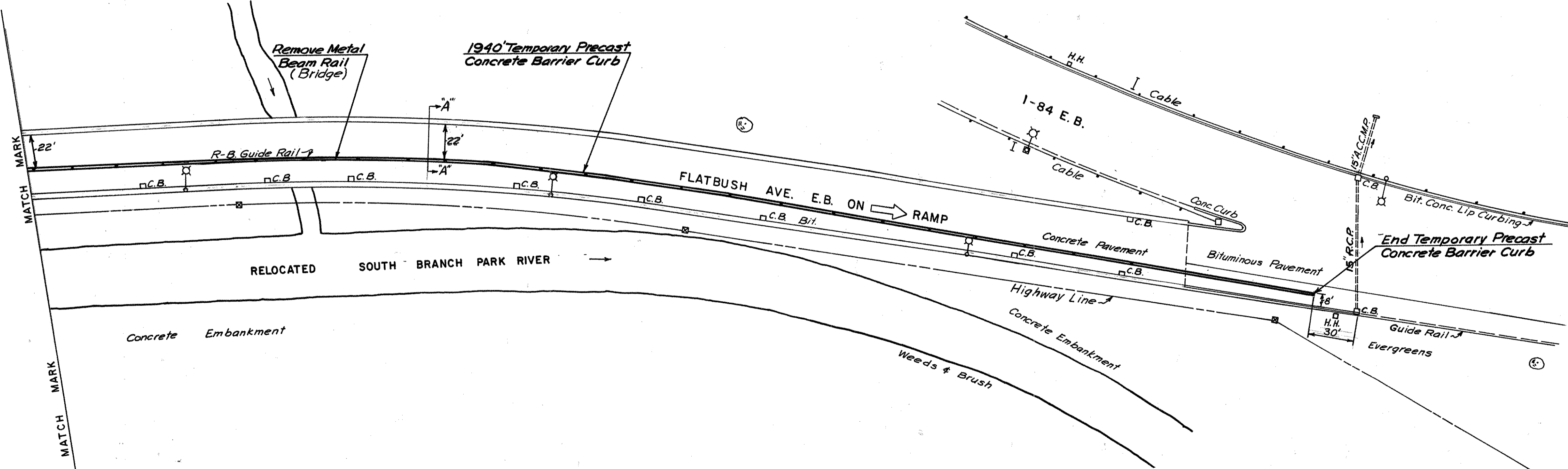

Checked By	DATE
By	DATE
Surveys	
Planned	
Traced	
Designed	
Reviewed	
Field Ck. Meas.	
PLAN	NO.
NOTEBOOK	

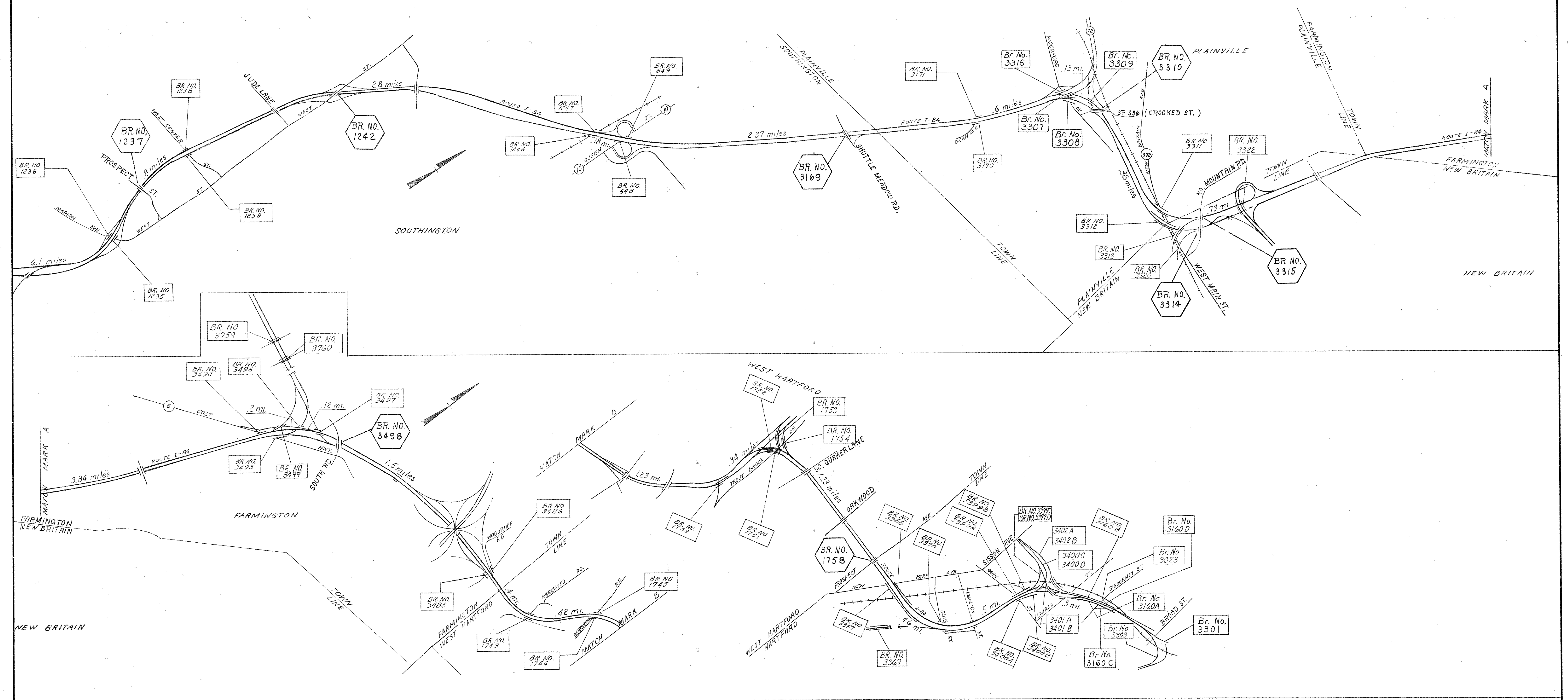

SECTION A-A

REVISIONS			
NO.	DATE	DESCRIPTION	REV. SHEET NO.

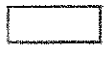

 Denote Bridges Which Are To Have Protective Fences Installed.
 Denotes Bridges Which Are To Have Deck Repairs, Membranes And Overlays. Approximate Mileage Is Shown Between These Bridges.

CONNECTICUT		
DEPARTMENT OF TRANSPORTATION		
SOUTHINGTON - HARTFORD		
INTERSTATE ROUTE 84		
59 STRUCTURES		
DECK REPAIRS		
INDEX PLAN		
ENGINEER BRIDGE DESIGN UNIT		
DESIGNER G.D.B.	DRAFTSMAN T.S.R.	CHECKER G.D.B.
APPROVED <i>[Signature]</i>	DATE 3/17/82	
NO. DATE	DESCRIPTION	STRUCTURE NO.

THE INFORMATION, INCLUDING ESTIMATED QUANTITIES OF WORK SHOWN ON THESE SHEETS IS BASED ON LIMITED INVESTIGATIONS BY THE STATE AND IS IN NO WAY WARRANTED TO INDICATE THE TRUE CONDITIONS OR ACTUAL QUANTITIES OR DISTRIBUTION OF QUANTITIES OF WORK WHICH WILL BE REQUIRED.

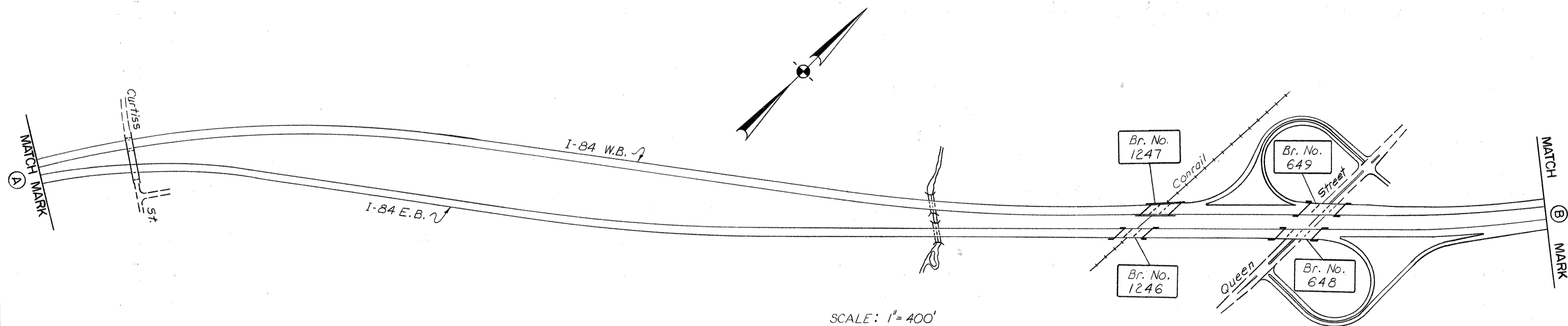
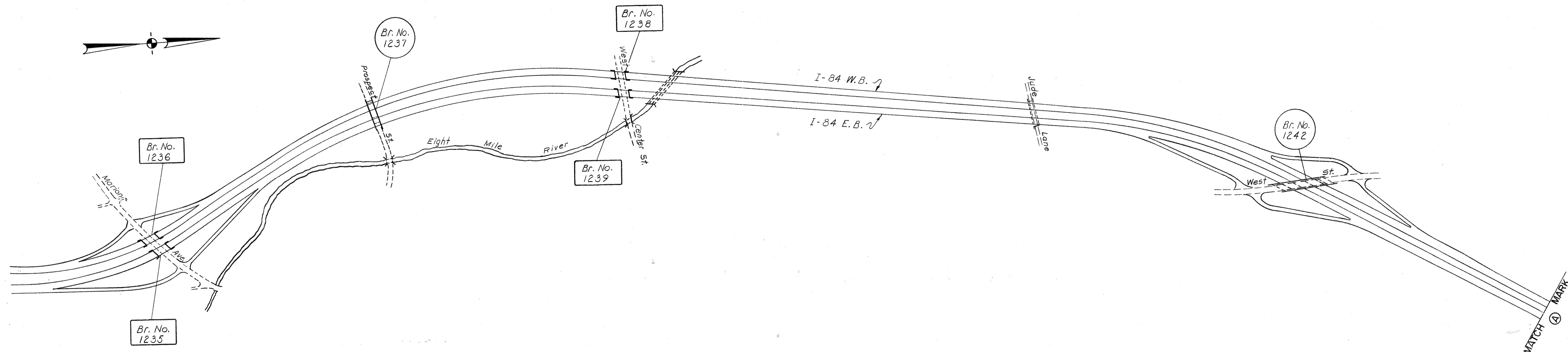

SCALE: 1" = 400'

LOCATION PLAN NOTES:
 Denotes bridges which are to have deck repairs, membrane and overlays. See Str. Sht. 7 thru 16 of 87.

Denotes bridges which are to have protective fences installed. See Str. Sht. 1 thru 9 of 9.

NO.	DATE	DESCRIPTION

STATE OF CONNECTICUT		
DEPARTMENT OF TRANSPORTATION		
SOUTHINGTON - HARTFORD		
INTERSTATE ROUTE 84		
59 STRUCTURES		
DECK REPAIRS		
LOCATION PLAN I		
ENGINEER BRIDGE DESIGN UNIT		
DESIGNER G. D. B.	DRAFTER J. J. C.	CHECKER G. D. B.
APPROVED <i>[Signature]</i>	DATE 3/17/82	
	STRUCTURE NO.	BRIDGE LOG NO. / STRUCTURE SHEET NO.
		2 of 87

THE INFORMATION, INCLUDING ESTIMATED QUANTITIES OF WORK SHOWN ON THESE SHEETS IS BASED ON LIMITED INVESTIGATIONS BY THE STATE AND IS IN NO WAY WARRANTED TO INDICATE THE TRUE CONDITIONS OR ACTUAL QUANTITIES OR DISTRIBUTION OF QUANTITIES OF WORK WHICH WILL BE REQUIRED.

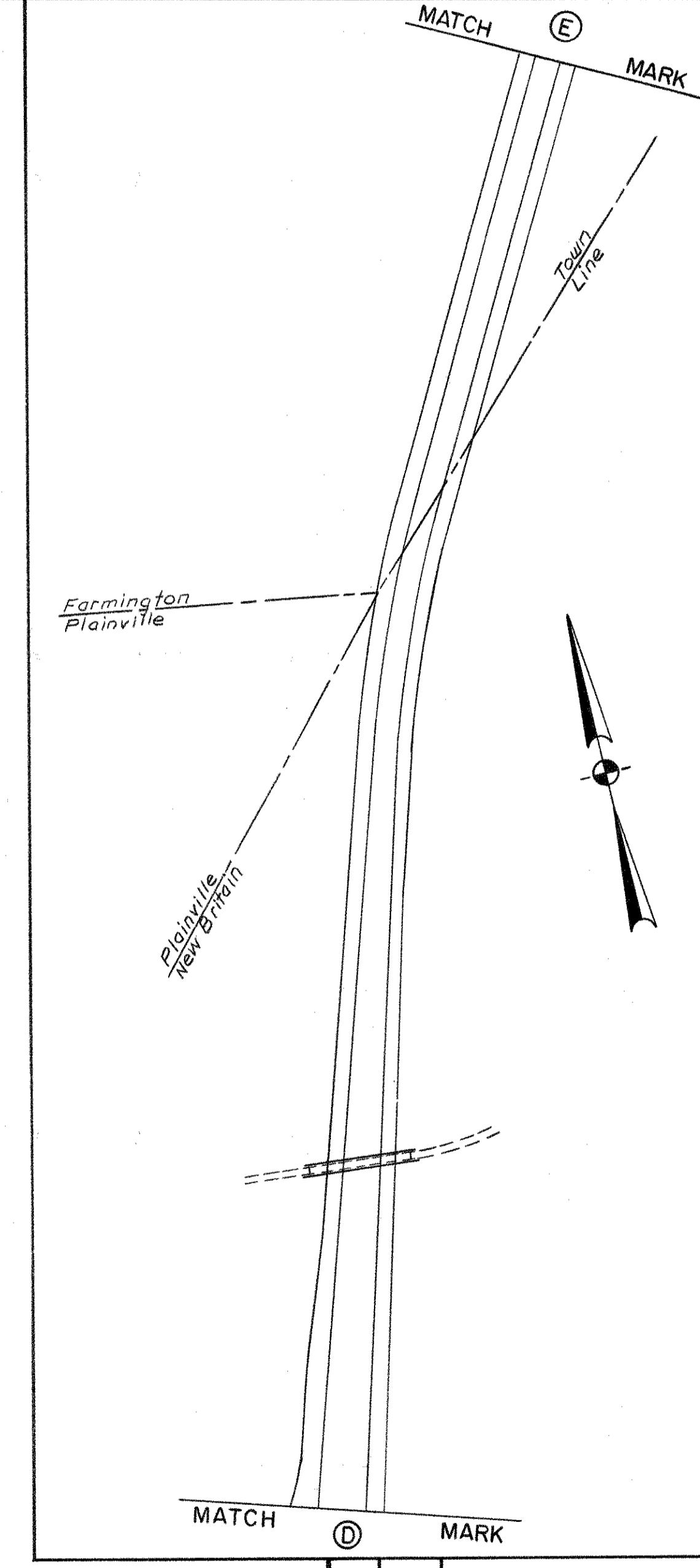
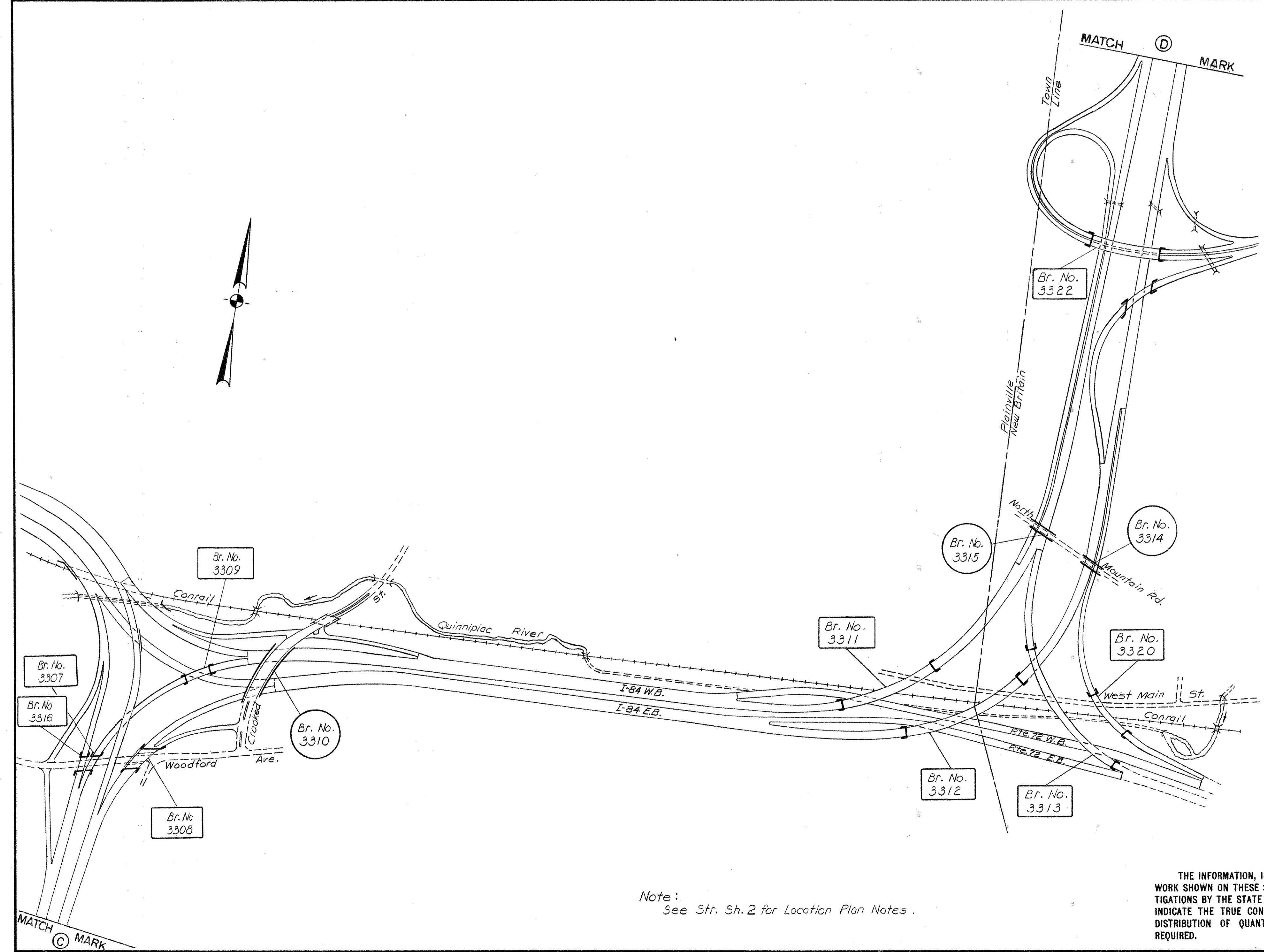
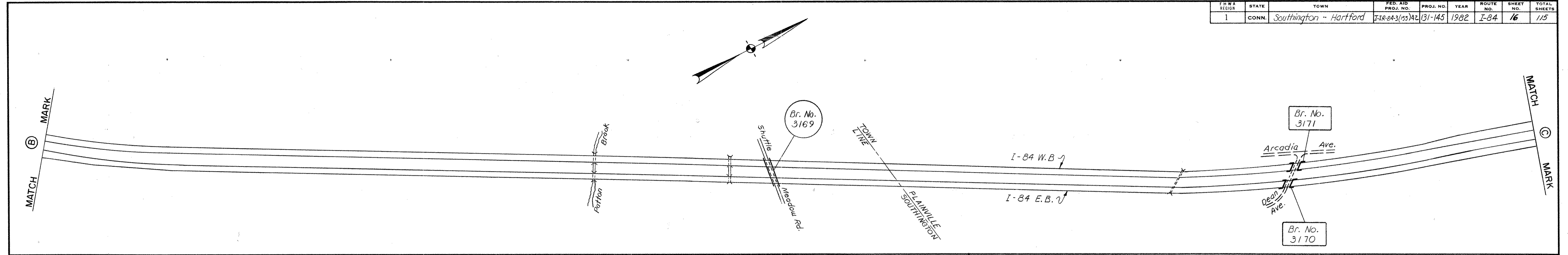

STATE OF CONNECTICUT			
DEPARTMENT OF TRANSPORTATION			
SOUTHINGTON - HARTFORD			
INTERSTATE ROUTE 84			
59 STRUCTURES			
DECK REPAIRS			
LOCATION PLAN II			
ENGINEER BRIDGE DESIGN UNIT			
DESIGNER G. D. B.		DRAFTER J. J. C.	
APPROVED <i>[Signature]</i>		CHECKER G. D. B.	
NO. DATE		DESCRIPTION	
REVISIONS		DATE 3/17/82	
STRUCTURE NO.		BRIDGE LOG NO.	
		STRUCTURE SHEET NO. 3 of 87	

Note: See Str. Sh. 2 for Location Plan Notes.

THE INFORMATION, INCLUDING ESTIMATED QUANTITIES OF WORK SHOWN ON THESE SHEETS IS BASED ON LIMITED INVESTIGATIONS BY THE STATE AND IS IN NO WAY WARRANTED TO INDICATE THE TRUE CONDITIONS OR ACTUAL QUANTITIES OR DISTRIBUTION OF QUANTITIES OF WORK WHICH WILL BE REQUIRED.

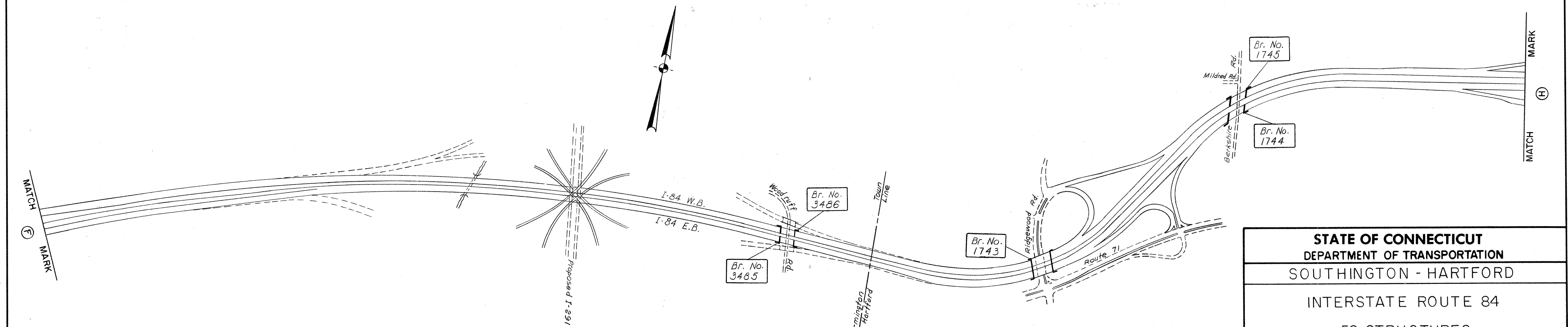
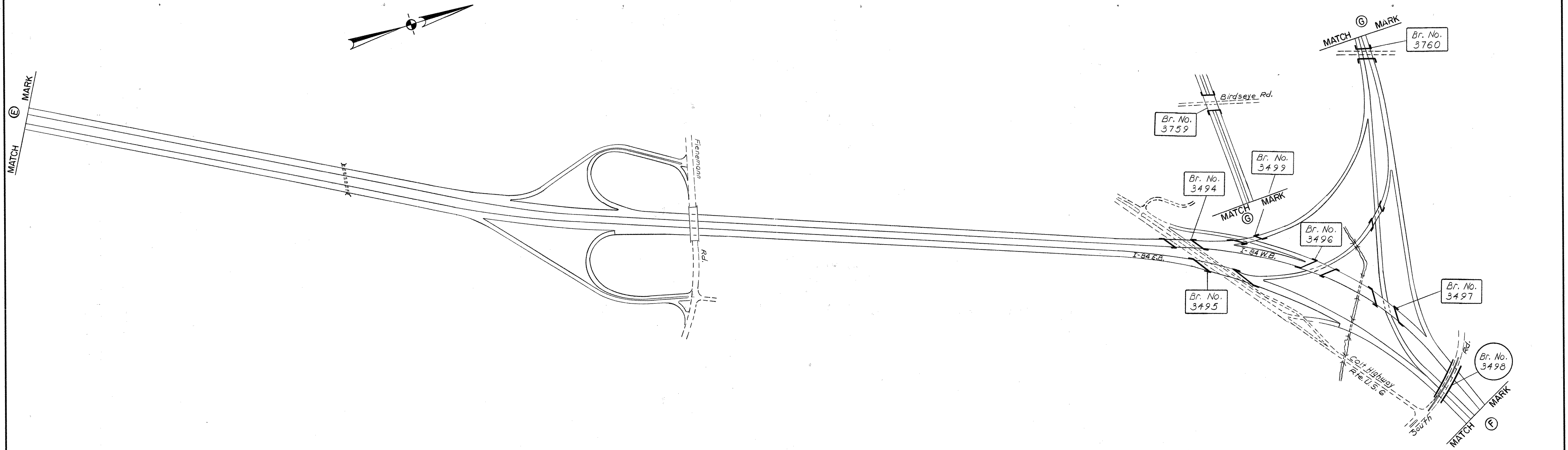

Note: See Str. Sht. 2 for Location Plan Notes.

THE INFORMATION, INCLUDING ESTIMATED QUANTITIES OF WORK SHOWN ON THESE SHEETS IS BASED ON LIMITED INVESTIGATIONS BY THE STATE AND IS IN NO WAY WARRANTED TO INDICATE THE TRUE CONDITIONS OR ACTUAL QUANTITIES OR DISTRIBUTION OF QUANTITIES OF WORK WHICH WILL BE REQUIRED.

STATE OF CONNECTICUT			
DEPARTMENT OF TRANSPORTATION			
SOUTHINGTON - HARTFORD			
INTERSTATE ROUTE 84			
59 STRUCTURES			
DECK REPAIRS			
LOCATION PLAN III			
ENGINEER BRIDGE DESIGN UNIT			
DESIGNER G. D. B.		DRAFTER J. J. C.	
CHECKER G. D. B.		DATE 3/17/82	
APPROVED <i>[Signature]</i>		BRIDGE LOS NO. 4	
STRUCTURE NO.		STRUCTURE SHEET NO. 4 of 87	

NO.	DATE	DESCRIPTION

F.H.A. REGION	STATE	TOWN	FED. AID PROJ. NO.	PROJ. NO.	YEAR	ROUTE NO.	SHEET NO.	TOTAL SHEETS
1	CONN.	Southington-Hartford	10-843(55)M2	131-145	1982	I-84	18	115

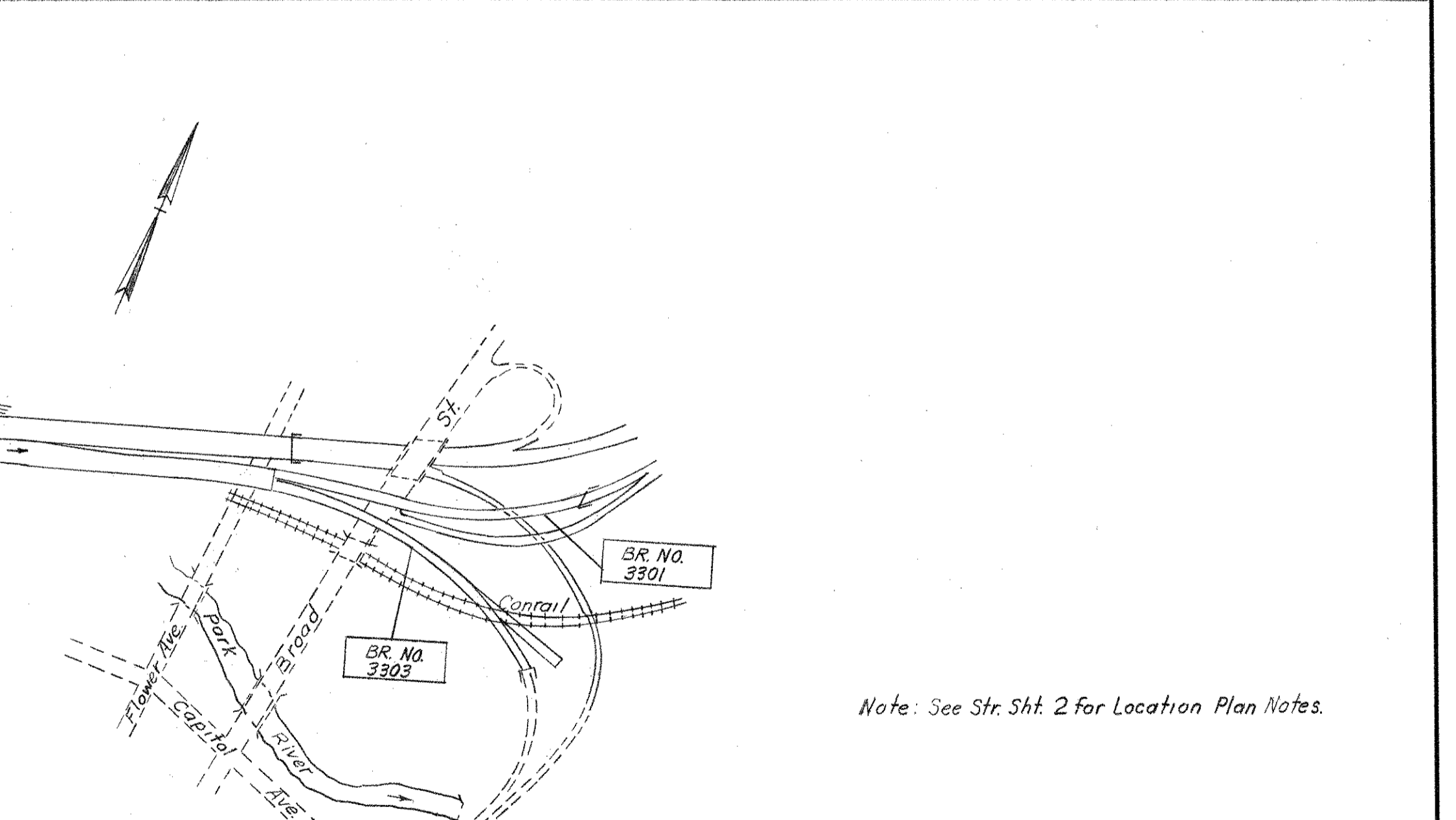
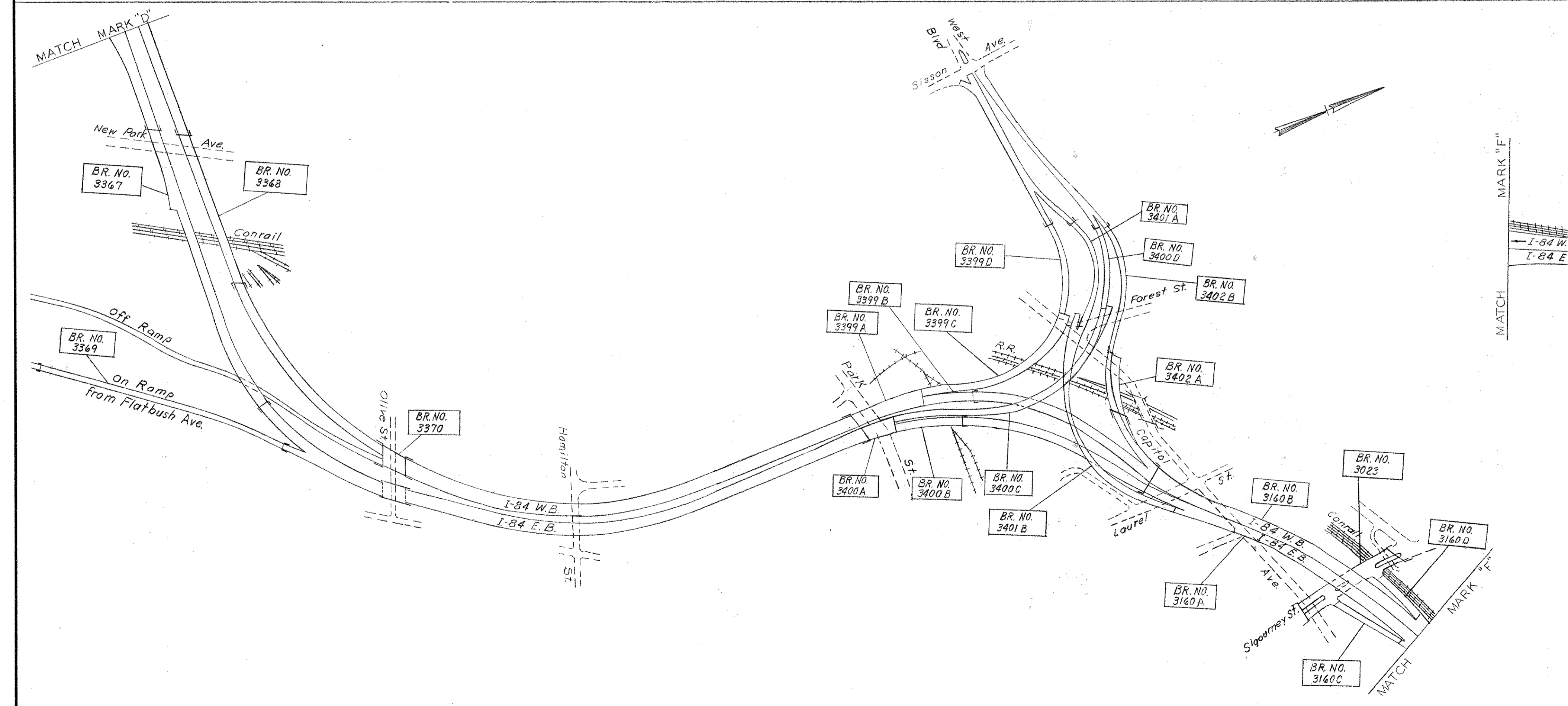
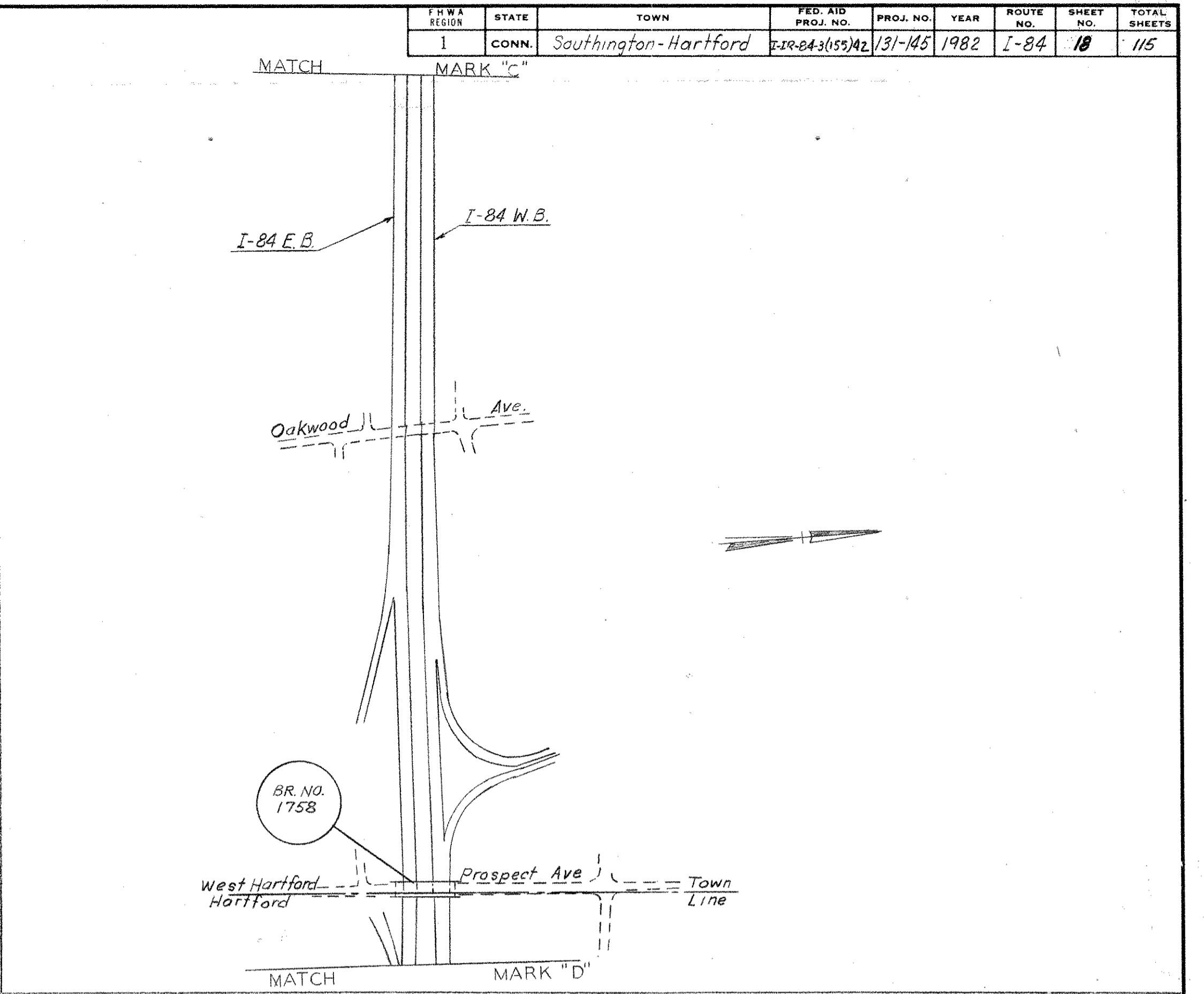
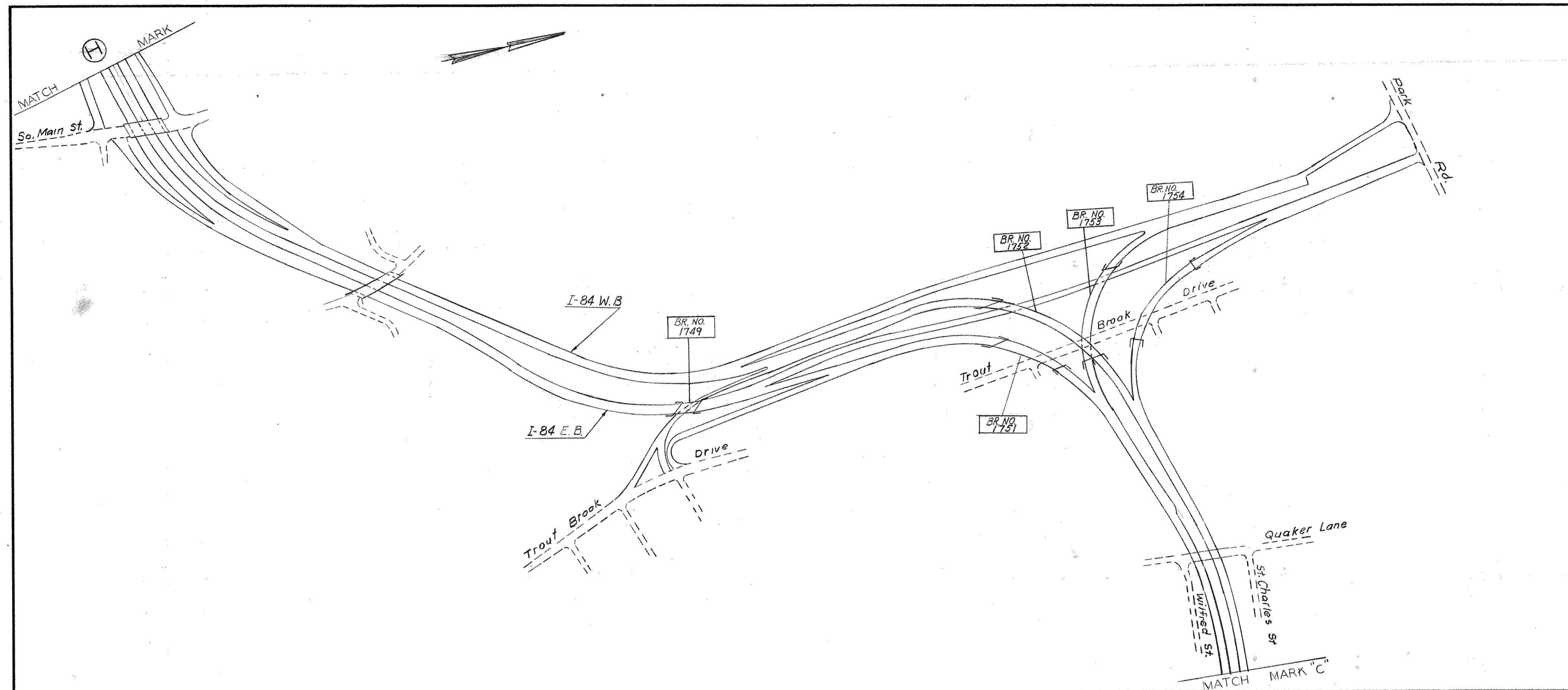

Note: See Str. Sht. 2 for Location Plan Notes.

STATE OF CONNECTICUT
DEPARTMENT OF TRANSPORTATION
 SOUTHINGTON - HARTFORD
 INTERSTATE ROUTE 84
 59 STRUCTURES
 DECK REPAIRS
 LOCATION PLAN IV

ENGINEER BRIDGE DESIGN UNIT		
DESIGNER G.D.B.	DRAFTER T.S.R.	CHECKER G.D.B.
APPROVED <i>[Signature]</i>	DATE 3/7/82	
NO. DATE	DESCRIPTION	STRUCTURE SHEET NO.
	REVISIONS	5 of 87

THE INFORMATION, INCLUDING ESTIMATED QUANTITIES OF WORK SHOWN ON THESE SHEETS IS BASED ON LIMITED INVESTIGATIONS BY THE STATE AND IS IN NO WAY WARRANTED TO INDICATE THE TRUE CONDITIONS OR ACTUAL QUANTITIES OR DISTRIBUTION OF QUANTITIES OF WORK WHICH WILL BE REQUIRED.

INDEX PLAN

FORM NO. 15A (10-4-80)	STATE	TOWN	PROJ. NO.	YEAR	ROUTE NO.	SHEET NO.	TOTAL SHEETS
	CONN.	SOUTHINGTON	I-84-3 (155)42	131-145	1982	I-84	2
						115	

I-84 BRIDGE DECK REPAIRS

SCALE IN FEET
 800' 400' 0 800'
 For Revision of 4/14/82 See Sheet 2A

BEGINNING OF FEDERAL AID PROJECT NO. I-84-3(155)42
 STATE PROJECT NO. 131-145
 I-84 @ STA. 105+30.00

Place 16B Construction Sign Ahead Of Last Exit Before Beginning Of Project.
 (Also Place Necessary 16A Construction Signs At Entrance Ramps In This Same Area.)

LEGEND

- PR. Type 1 - Pavement Resurfacing Type 1
 3/4" Bit. Conc. - Class 14 On
 1 3/4" Bit. Conc. - Class 1
- PR. Type 2 - Pavement Resurfacing Type 2
 3/4" Bit. Conc. - Class 14 On
 2 1/4" Bit. Conc. - Class 1
- - Raise Catch Basin Grate
- T.D. - For Details Of Applicable Touchdowns - See Miscellaneous Details

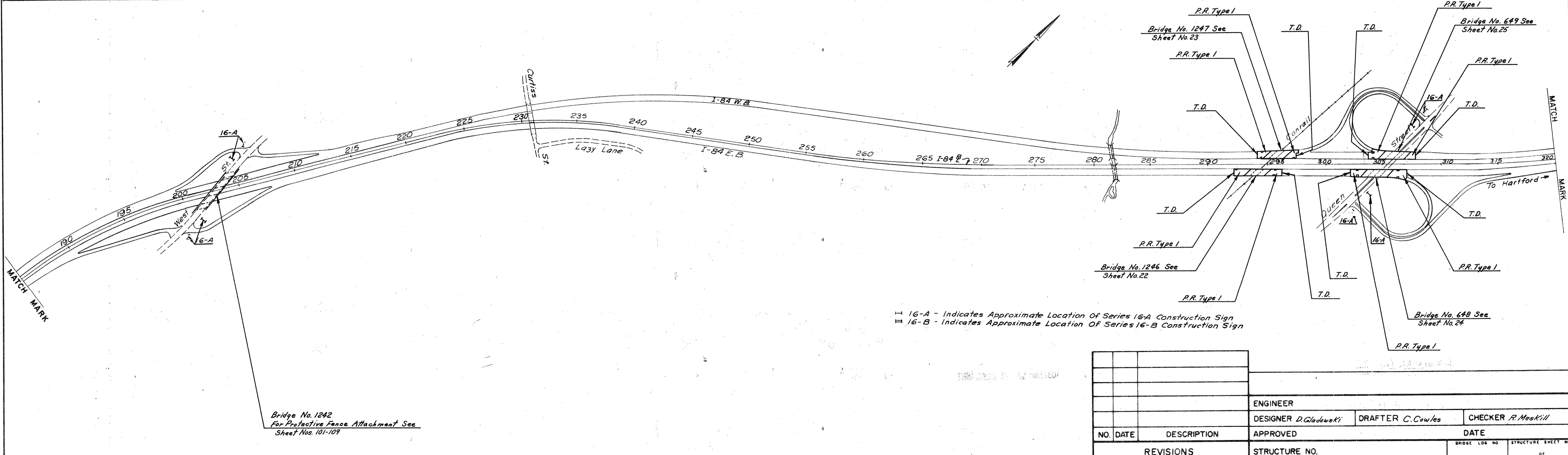
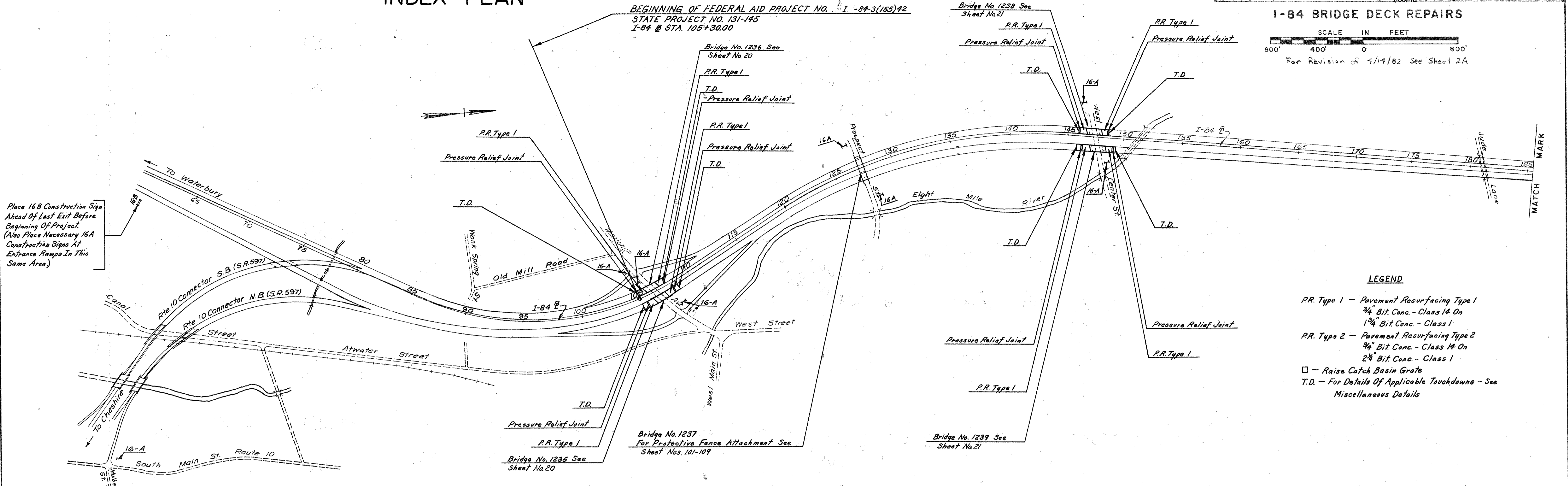

16-A - Indicates Approximate Location Of Series 16A Construction Sign
 16-B - Indicates Approximate Location Of Series 16-B Construction Sign

NO. DATE		DESCRIPTION	APPROVED	DATE
REVISIONS		STRUCTURE NO.	BRIDGE LOG NO.	STRUCTURE SHEET NO.

ENGINEER
 DESIGNER D. Gladuski
 DRAFTER C. Cowles
 CHECKER R. Moskitt

505 01

FHW A REGION	STATE	TOWN	FED AID PROJ NO	PROJ NO	YEAR	ROUTE NO	SHEET NO	TOTAL SHEETS
1	CONN	Southington	131-145	131-145	1982	I-84	20	115

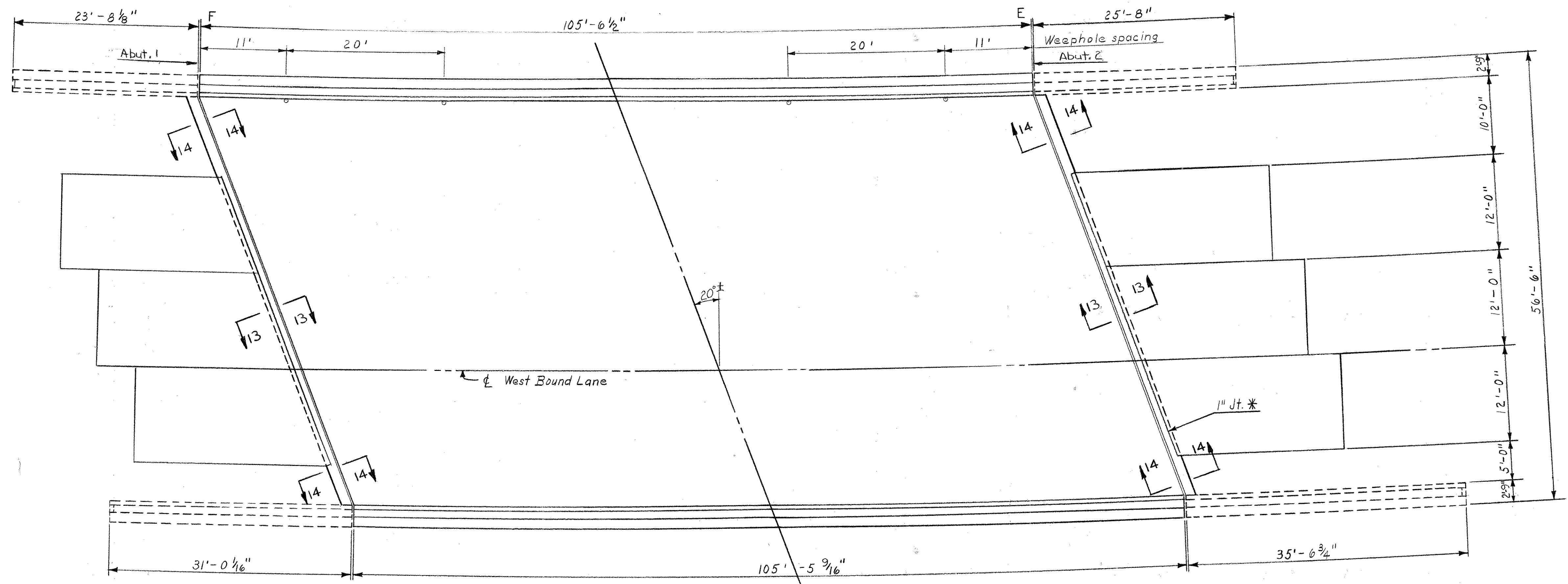

DECK PLAN - BRIDGE NO. 1236
Scale 1/8" = 1'-0"

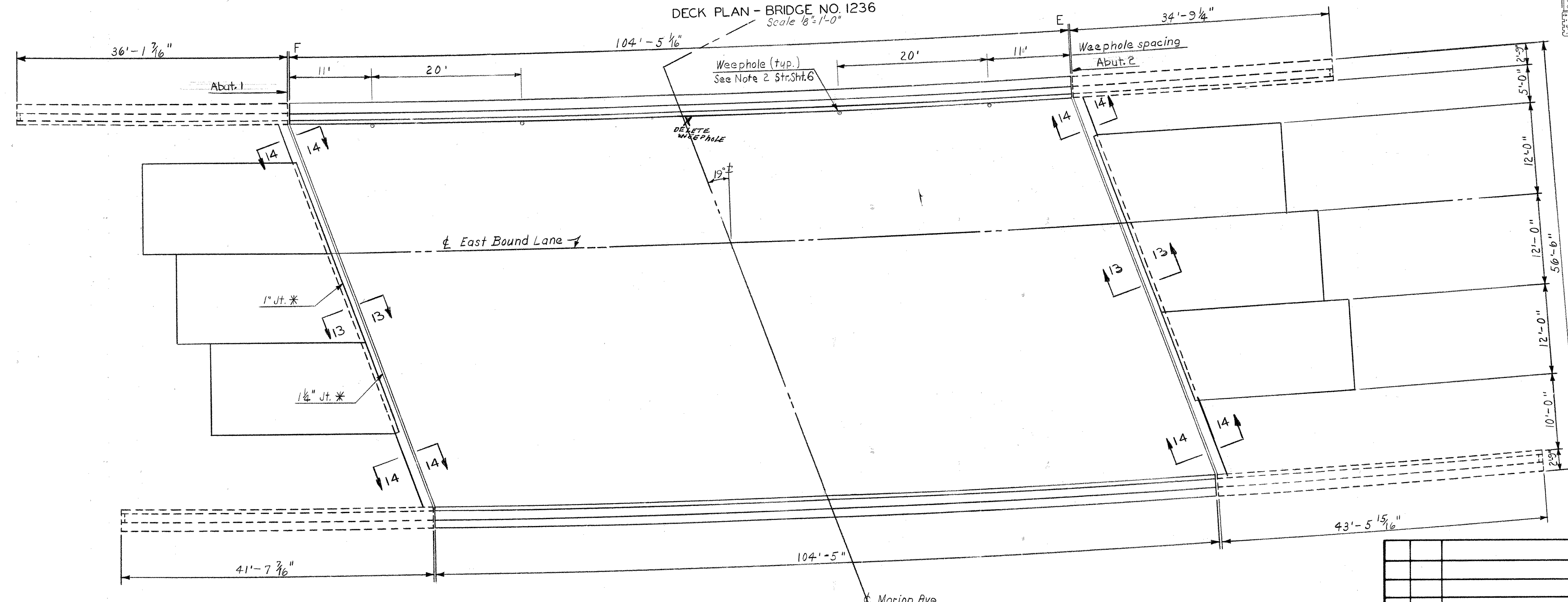

DECK PLAN - BRIDGE NO. 1235
Scale 1/8" = 1'-0"

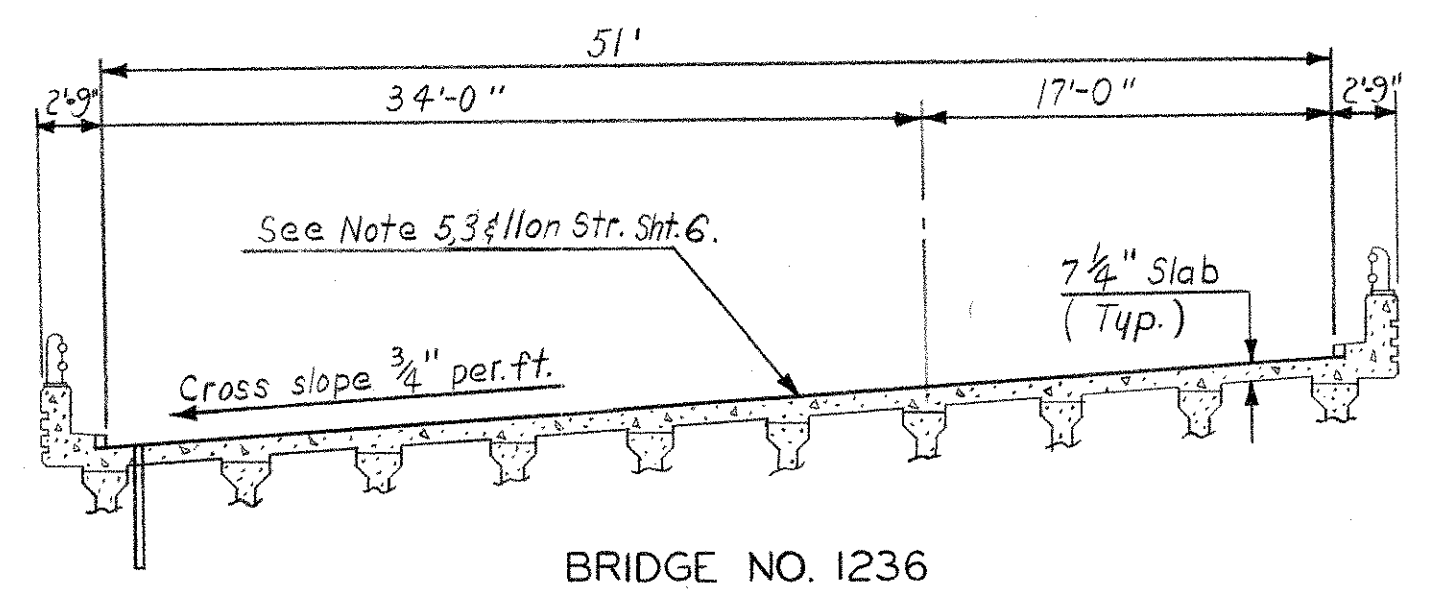

BRIDGE NO. 1236

* Jt. Dimensions taken 3/16/81.

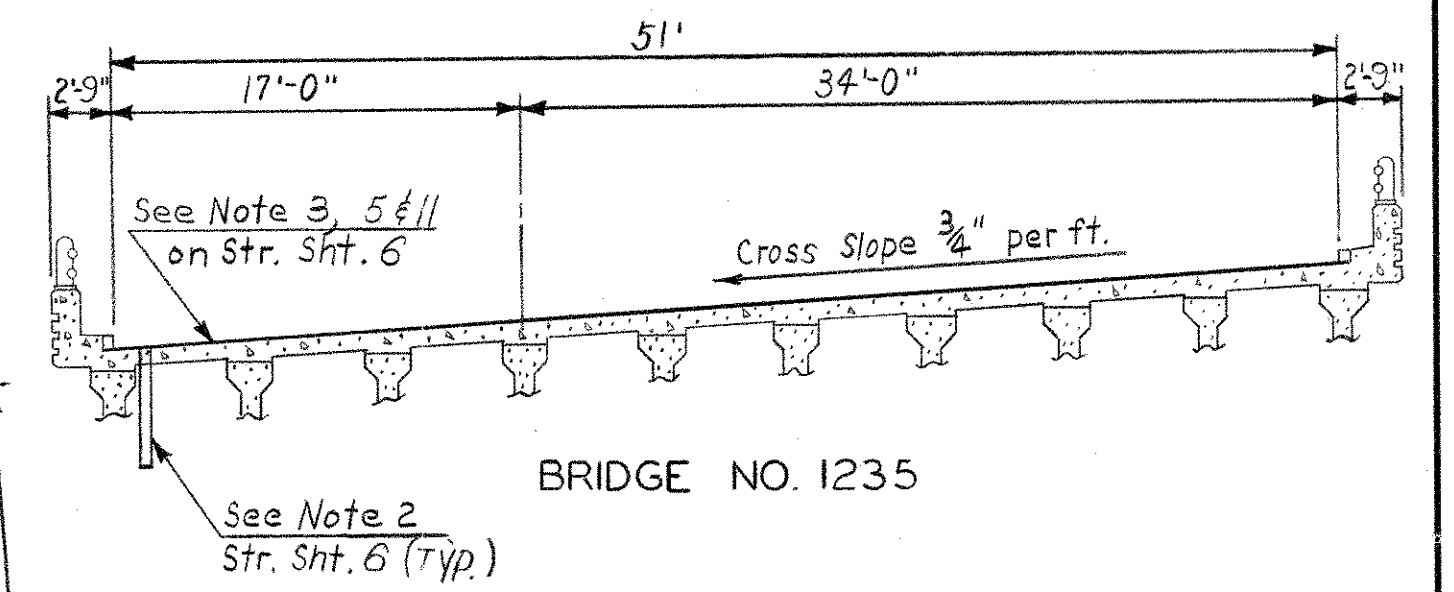

BRIDGE NO. 1235

TYPICAL BRIDGE SECTION

Looking North
Scale 1/8" = 1'-0"

Note: For Sections 13-13 & 14-14 see str. sh. No. 83.

CONNECTICUT
DEPARTMENT OF TRANSPORTATION
SOUTHINGTON - HARTFORD
INTERSTATE ROUTE 84
59 STRUCTURES
DECK REPAIRS
I-84 E.B. & W.B. OVER MARION AVE.

ENGINEER BRIDGE DESIGN UNIT		
DESIGNER J.P.L.	DRAFTER R.G.	CHECKER G.D.B.
APPROVED <i>[Signature]</i>	DATE 3/17/82	
STRUCTURE NO. 131-145-1235-1236		BRIDGE LOG NO. 1235 1236
		STRUCTURE SHEET NO. 7 of 87

THE INFORMATION, INCLUDING ESTIMATED QUANTITIES OF WORK SHOWN ON THESE SHEETS IS BASED ON LIMITED INVESTIGATIONS BY THE STATE AND IS IN NO WAY WARRANTED TO INDICATE THE TRUE CONDITIONS OR ACTUAL QUANTITIES OR DISTRIBUTION OF QUANTITIES OF WORK WHICH WILL BE REQUIRED.

NO.	DATE	DESCRIPTION

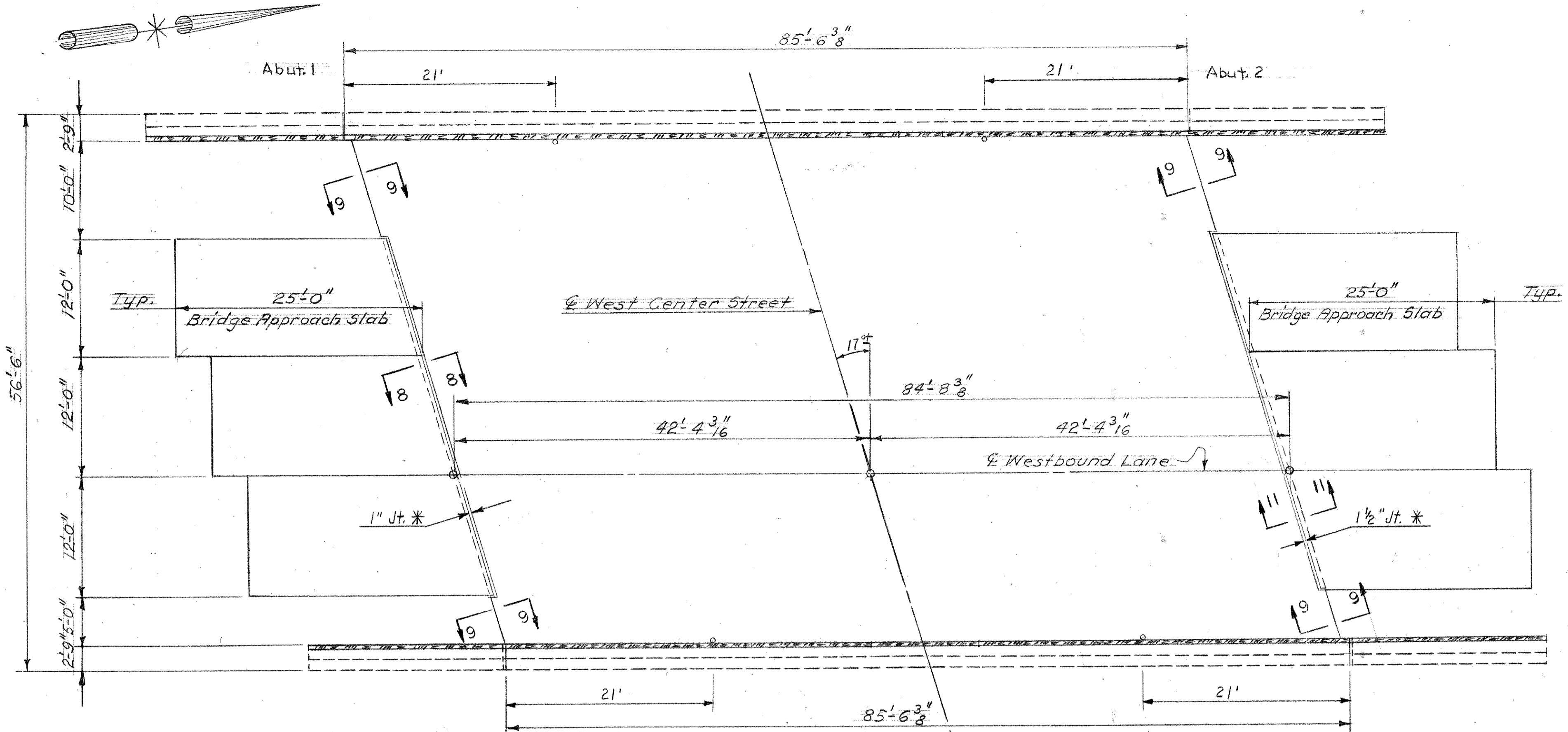

DECK PLAN-BRIDGE NO. 1238
I-84 OVER WEST CENTER STREET
Scale: 1/8" = 1'-0"

* Jt. dimensions taken 3/16/81

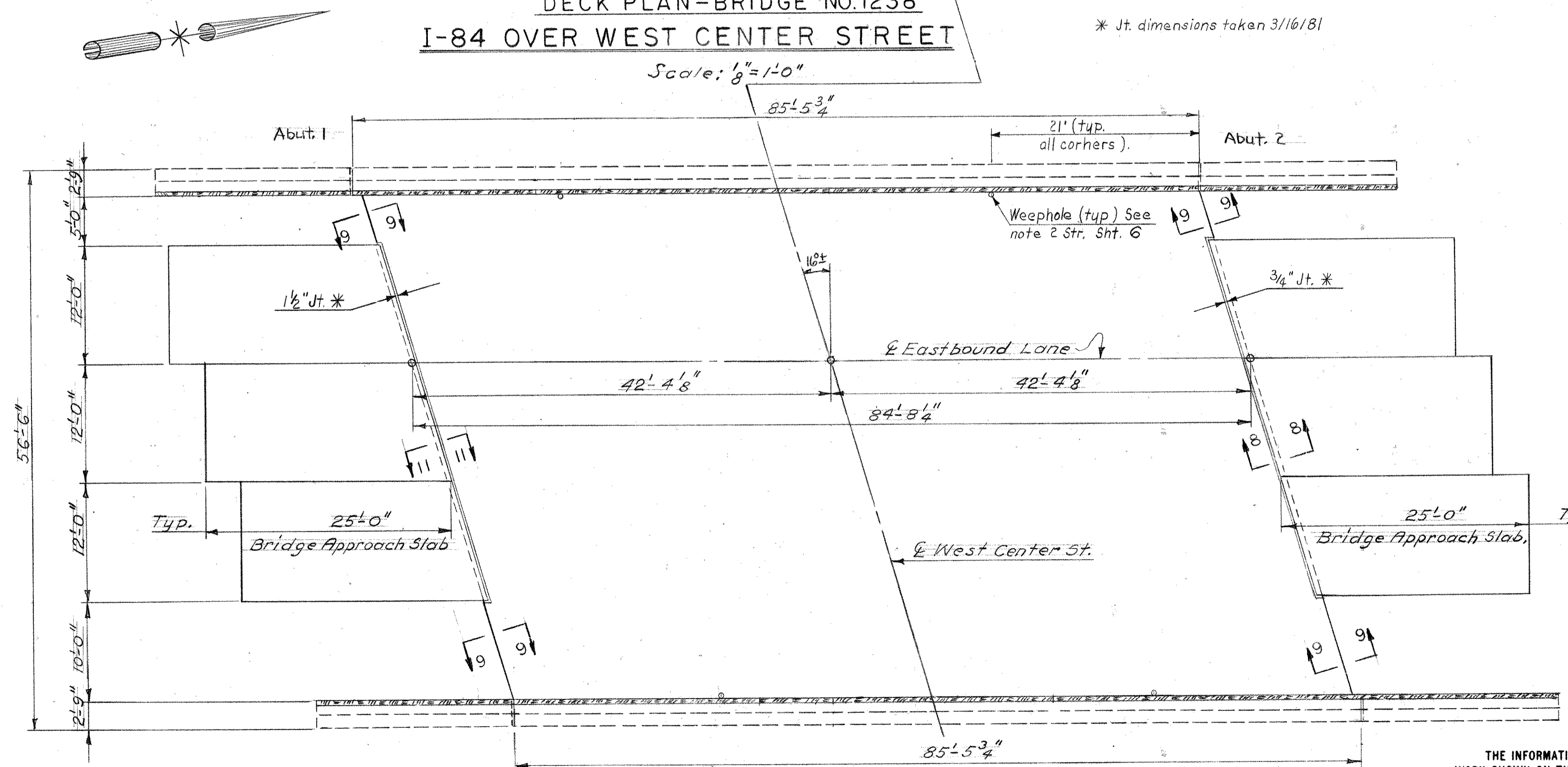

DECK PLAN-BRIDGE NO. 1239
I-84 OVER WEST CENTER STREET
Scale: 1/8" = 1'-0"

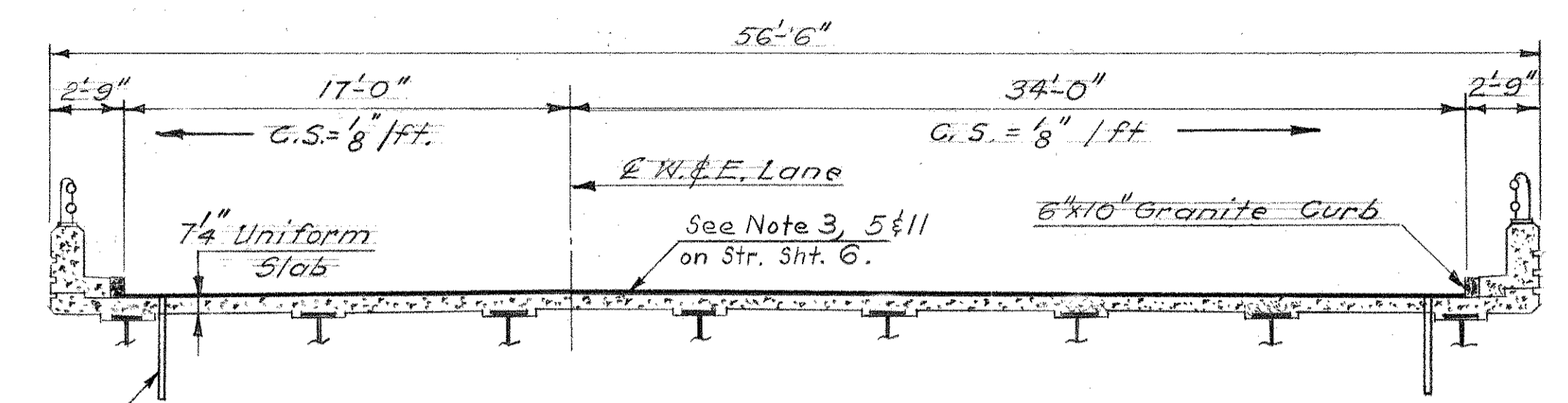

BRIDGE NOS 1238 & 1239
TYPICAL BRIDGE SECTION
Scale: 3/16" = 1'-0"

Note: For Sections 8-8, 9-9 See Str. Sht. 86.
For Section 11-11 See Str. Sht. 82.

CONNECTICUT DEPARTMENT OF TRANSPORTATION		
SOUTHINGTON - HARTFORD		
INTERSTATE ROUTE 84		
59 STRUCTURES		
DECK REPAIRS		
I-84 E.B. & W.B. OVER WEST CENTER ST.		
ENGINEER BRIDGE DESIGN UNIT		
DESIGNER J.P.L.	DRAFTER G.O.K.	CHECKER G.D.B.
APPROVED <i>[Signature]</i>	DATE 3/17/82	
NO. DATE	DESCRIPTION	BRIDGE LOG NO. STRUCTURE SHEET NO.
	REVISIONS	1238-1239 8 of 87

THE INFORMATION, INCLUDING ESTIMATED QUANTITIES OF WORK SHOWN ON THESE SHEETS IS BASED ON LIMITED INVESTIGATIONS BY THE STATE AND IS IN NO WAY WARRANTED TO INDICATE THE TRUE CONDITIONS OR ACTUAL QUANTITIES OR DISTRIBUTION OF QUANTITIES OF WORK WHICH WILL BE REQUIRED.

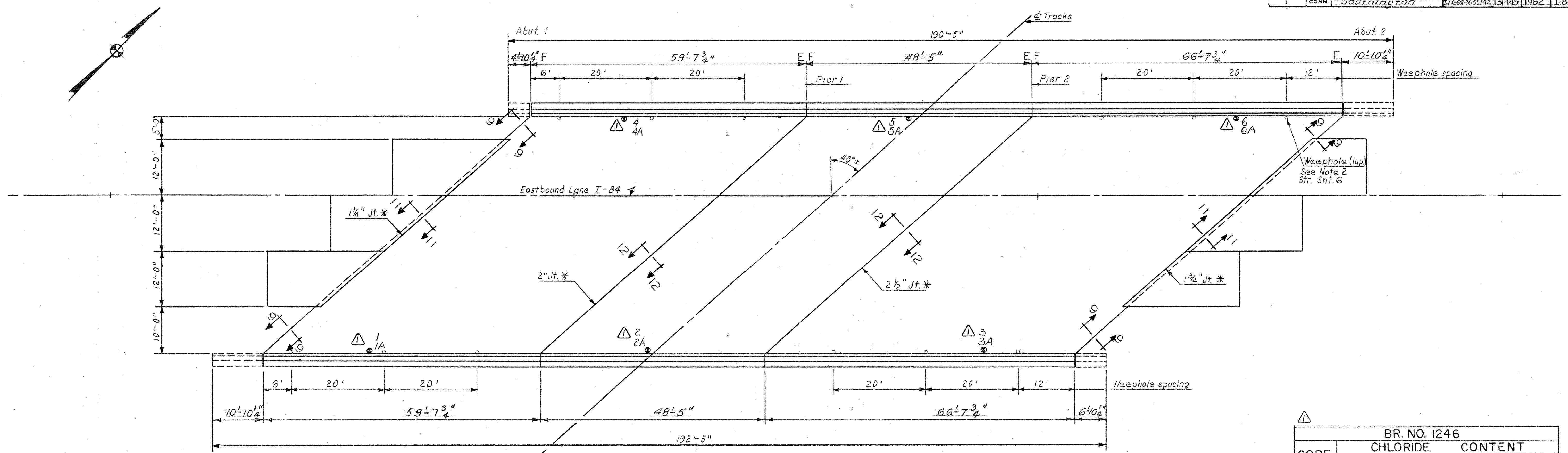

CORE NO.	BR. NO. 1246			
	CHLORIDE		CONTENT	
	% BY WT.	LBS./C.Y.	% BY WT.	LBS./C.Y.
(See Note 4 Str. Sht. 6) Date 1-8-82				
1	0.121	4.743	0.106	4.155
1A	0.102	3.998	—	—
2	0.112	4.390	—	—
2A	0.071	2.783	—	—
3	0.083	3.254	—	—
3A	0.037	1.450	—	—
4	0.164	6.429	0.162	6.350
4A	0.075	2.940	—	—
5	0.223	8.742	0.210	8.232
5A	0.136	5.331	—	—
6	0.135	5.292	0.126	4.939
6A	0.079	3.097	—	—

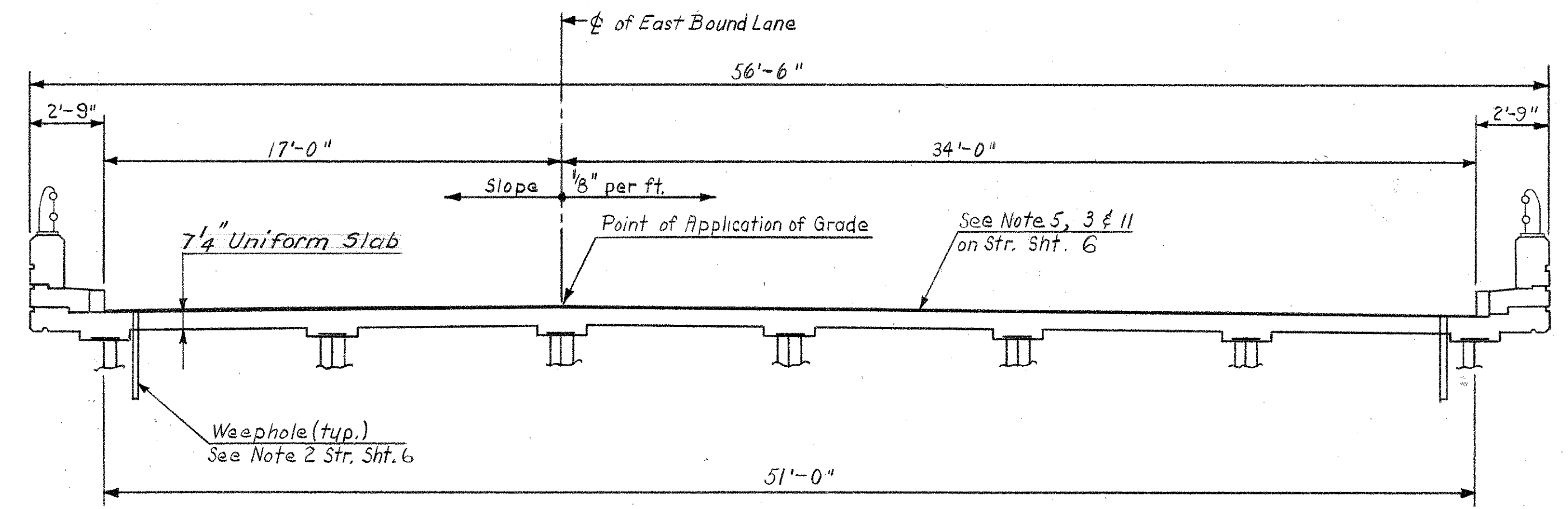

Note: For Section 9-9 see Str. Sht. 86.
For Sections 11-11, 12-12 see Str. Sht. 82.

CONNECTICUT DEPARTMENT OF TRANSPORTATION		
SOUTHINGTON - HARTFORD		
INTERSTATE ROUTE 84		
59 STRUCTURES		
DECK REPAIRS		
I-84 E.B. OVER P.C.R.R.		
ENGINEER BRIDGE DESIGN UNIT		
DESIGNER J.P.L.	DRAFTER R.G.	CHECKER G.D.B.
NO. DATE	DESCRIPTION	APPROVED <i>[Signature]</i> DATE 3/17/82
REVISIONS		STRUCTURE NO. 131-145-1246
		BRIDGE LOG NO. 1246
		STRUCTURE SHEET NO. 9 of 87

THE INFORMATION, INCLUDING ESTIMATED QUANTITIES OF WORK SHOWN ON THESE SHEETS IS BASED ON LIMITED INVESTIGATIONS BY THE STATE AND IS IN NO WAY WARRANTED TO INDICATE THE TRUE CONDITIONS OR ACTUAL QUANTITIES OR DISTRIBUTION OF QUANTITIES OF WORK WHICH WILL BE REQUIRED.

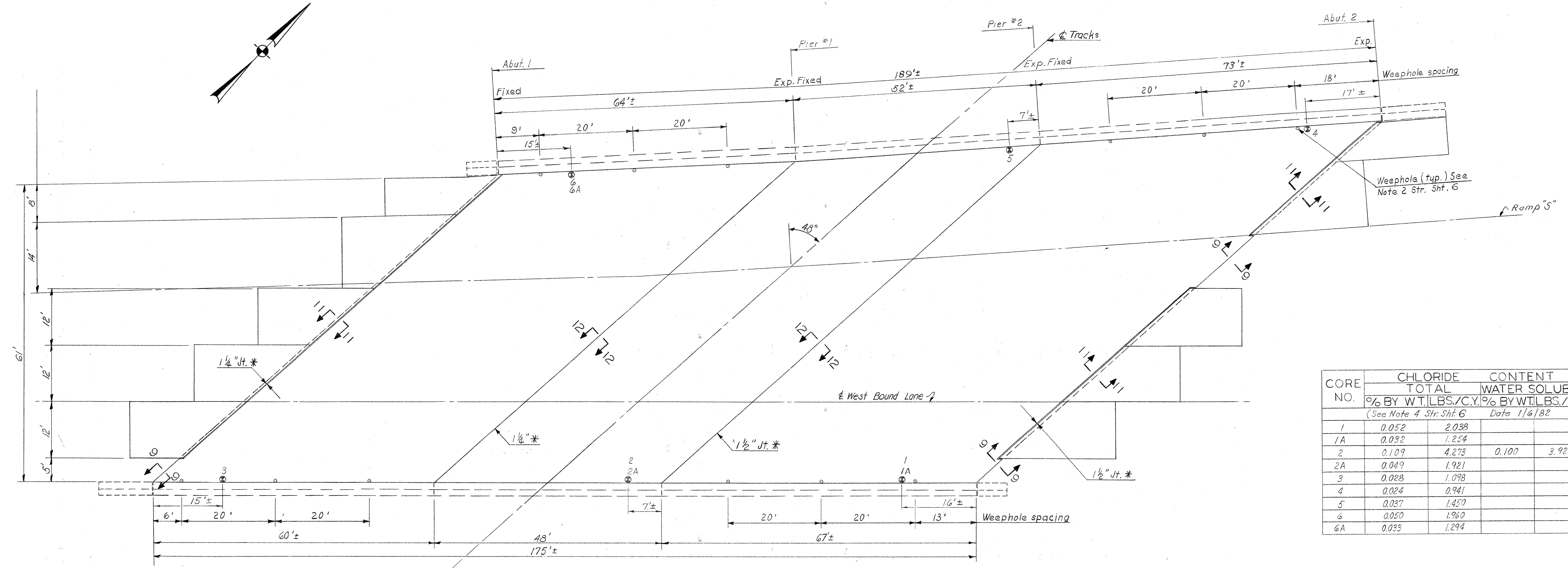

CORE NO.	CHLORIDE CONTENT		DATE 1/6/82	
	TOTAL % BY WT/LBS./CY.	WATER SOLUBLE % BY WT/LBS./CY.		
1	0.052	2.038		
1A	0.032	1.254		
2	0.109	4.273	0.100	3.920
2A	0.049	1.921		
3	0.028	1.098		
4	0.024	0.941		
5	0.037	1.450		
6	0.050	1.960		
6A	0.033	1.294		

INTERSTATE RTE. NO. 84
OVER
PCRR
WEST BOUND LANE
Scale 3/32" = 1'-0"

* Joint Dimensions taken 3/19/81
⊙ Denotes Core Location

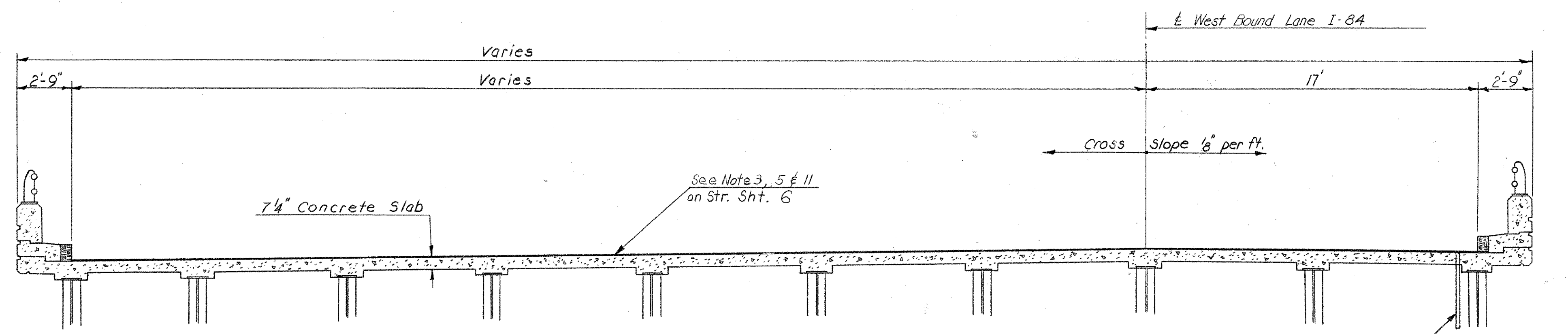

Note: For Section 9-9 see Str. Sht. 86.
For Sections 11-11, 12-12 see Str. Sht. 82

CONNECTICUT DEPARTMENT OF TRANSPORTATION SOUTHINGTON - HARTFORD INTERSTATE ROUTE 84 59 STRUCTURES DECK REPAIRS I-84 W.B. OVER P.C.R.R.		
ENGINEER BRIDGE DESIGN UNIT		
DESIGNER J.P.L.	DRAFTER J.J.C.	CHECKER G.D.B.
APPROVED <i>[Signature]</i>	DATE 3/17/82	
STRUCTURE NO. 131-145-01247		BRIDGE LOG NO. 01247
REVISIONS		STRUCTURE SHEET NO. 10 of 87

THE INFORMATION, INCLUDING ESTIMATED QUANTITIES OF WORK SHOWN ON THESE SHEETS IS BASED ON LIMITED INVESTIGATIONS BY THE STATE AND IS IN NO WAY WARRANTED TO INDICATE THE TRUE CONDITIONS OR ACTUAL QUANTITIES OR DISTRIBUTION OF QUANTITIES OF WORK WHICH WILL BE REQUIRED.

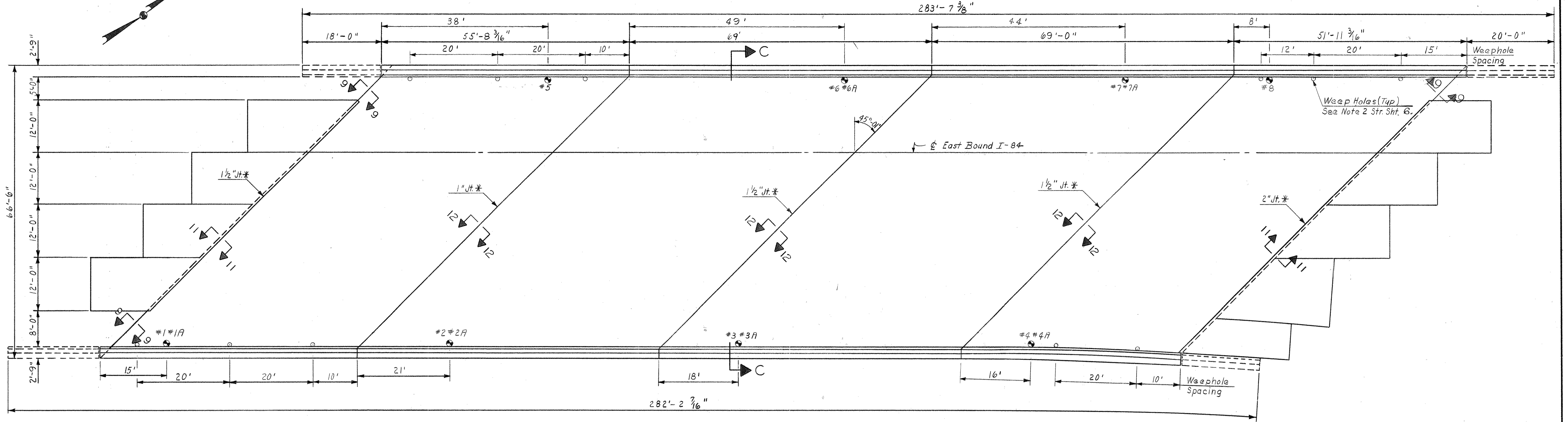

PLAN
SCALE 3/32" = 1'-0"

⊙ Denotes Core Location
* Jt. Dimension Taken 3-19-81.

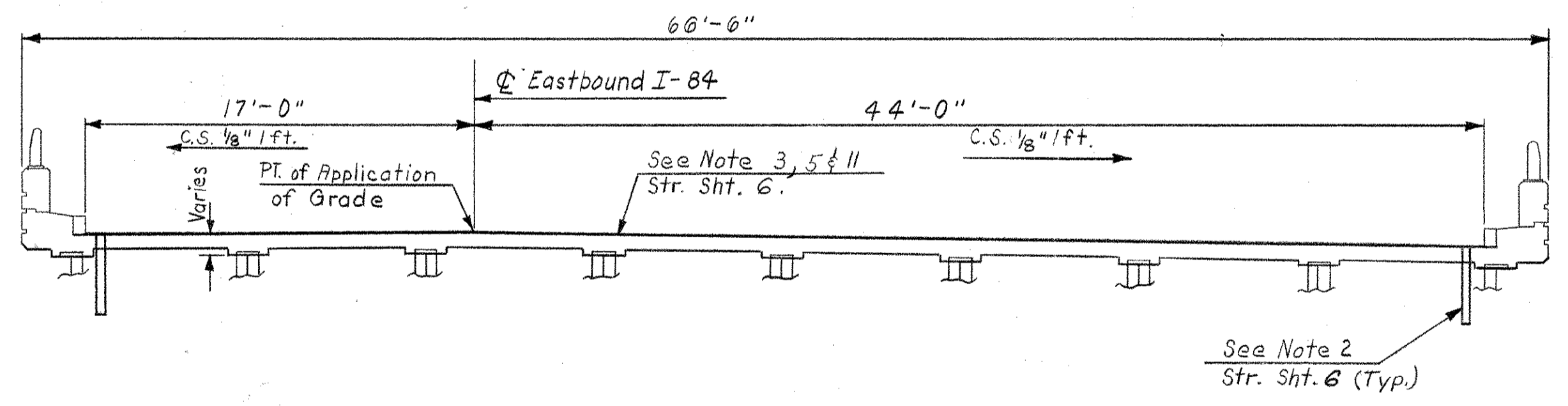

SECTION C-C
SCALE 3/16" = 1'-0"

BR. NO. 648

CORE NO.	CHLORIDE CONTENT		WATER SOLUBLE	
	% BY WT.	LBS./CY.	% BY WT.	LBS./CY.
1	0.065	2.548		
1A	0.038	1.490		
2	0.070	2.744		
2A	0.040	1.568		
3	0.093	3.046	0.090	3.528
3A	0.054	2.117		
4	0.063	2.470		
4A	0.044	1.725		
5	0.036	1.411		
6	0.087	3.410		
6A	0.071	2.783		
7	0.057	2.234		
7A	0.015	0.588		
8	0.029	1.137		

(See Note 4 Str. Sht. 6 Date 11/6/82)

Note: For Section 9-9 see Str. Sht. 86.
For Sections 11-11, 12-12 see Str. Sht. 82.

CONNECTICUT DEPARTMENT OF TRANSPORTATION		
SOUTHINGTON - HARTFORD		
INTERSTATE ROUTE 84		
59 STRUCTURES		
DECK REPAIRS		
I-84 E.B. OVER ROUTE 10 (QUEEN ST.)		
ENGINEER BRIDGE DESIGN UNIT		
DESIGNER J.P.L.	DRAFTER R.G.	CHECKER G.D.B.
NO. DATE	DESCRIPTION	APPROVED DATE 3/17/82
REVISIONS		STRUCTURE NO. 131-145-648
		BRIDGE LOG NO. 648
		STRUCTURE SHEET NO. 11 of 87

THE INFORMATION, INCLUDING ESTIMATED QUANTITIES OF WORK SHOWN ON THESE SHEETS IS BASED ON LIMITED INVESTIGATIONS BY THE STATE AND IS IN NO WAY WARRANTED TO INDICATE THE TRUE CONDITIONS OR ACTUAL QUANTITIES OR DISTRIBUTION OF QUANTITIES OF WORK WHICH WILL BE REQUIRED.

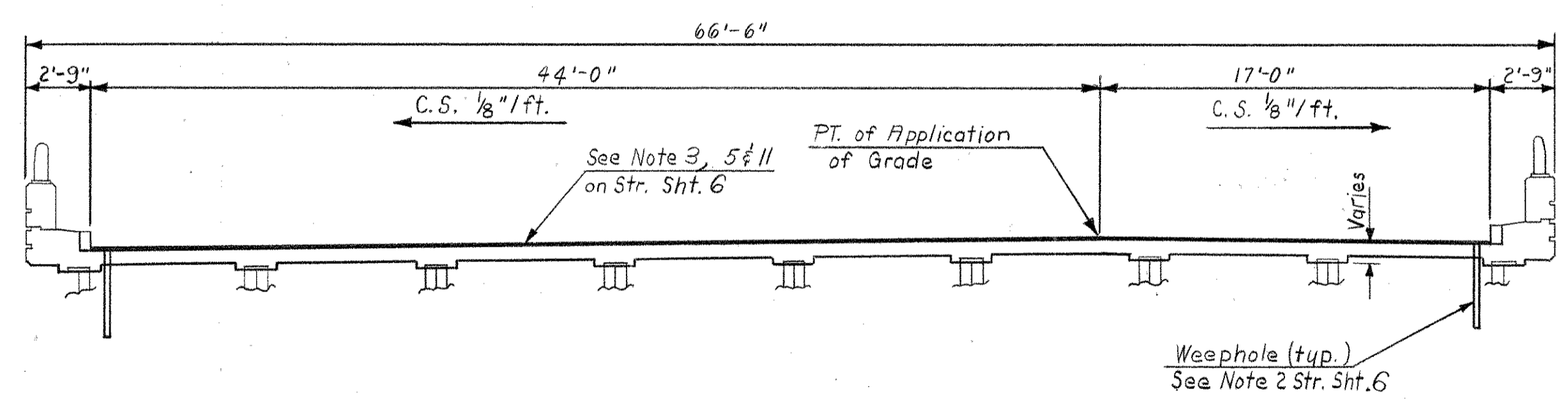
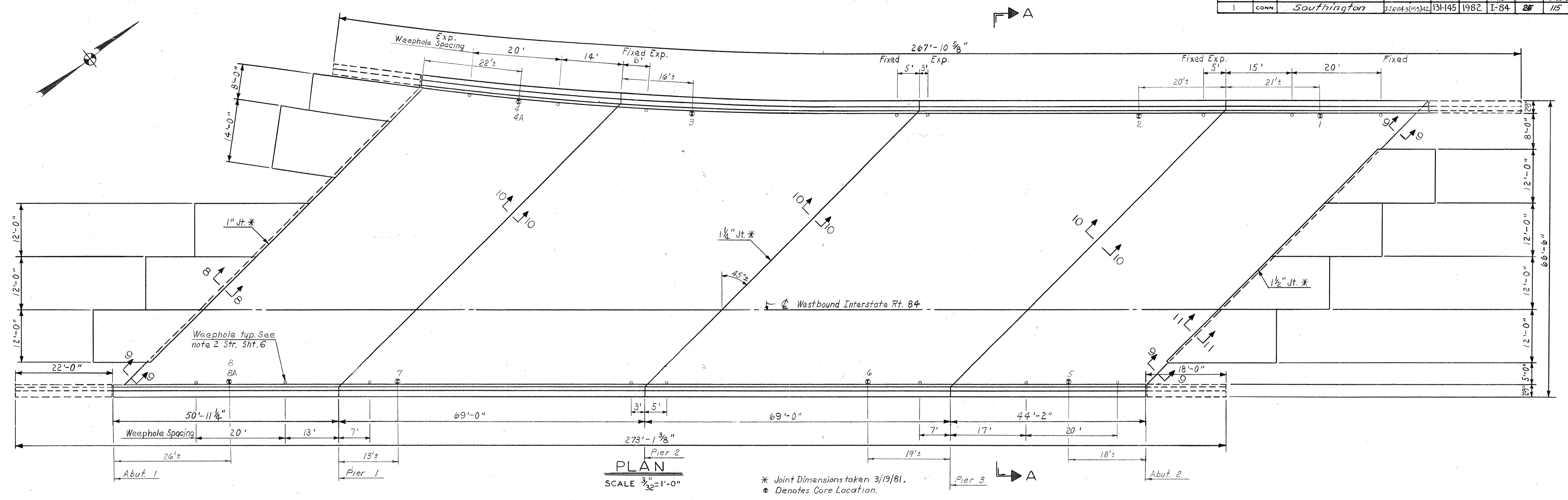

CORE NO.	CHLORIDE CONTENT		WATER SOLUBLE	
	TOTAL	% BY WT. LBS./C.Y.	% BY WT. LBS./C.Y.	% BY WT. LBS./C.Y.
1	0.047	1.842		
2	0.013	0.510		
3	0.023	0.902		
4	0.050	1.960		
4A	0.036	1.411		
5	0.028	1.098		
6	0.038	1.490		
7	0.033	1.294		
8	0.052	2.038	0.052	2.038
8A	0.041	1.607		

(See Note 4 Str. Sht. 6) Date 1/6/82

Note: For Sections 8-8, 9-9 & 10-10 see Str. Sht. 86.
For Section 11-11, see Str. Sht. 82.

CONNECTICUT
DEPARTMENT OF TRANSPORTATION
SOUTHINGTON - HARTFORD

INTERSTATE ROUTE 84
59 STRUCTURES
DECK REPAIRS
I-84 W.B. OVER ROUTE 10 (QUEEN ST.)

ENGINEER BRIDGE DESIGN UNIT		DESIGNER J.P.L.		DRAFTER R.G.		CHECKER G.D.B.	
APPROVED <i>[Signature]</i>		DATE 3/17/82		BRIDGE LOG NO. 649		STRUCTURE SHEET NO. 12 of 87	
NO. DATE		DESCRIPTION		STRUCTURE NO. 131-145-649			
REVISIONS							

THE INFORMATION, INCLUDING ESTIMATED QUANTITIES OF WORK SHOWN ON THESE SHEETS IS BASED ON LIMITED INVESTIGATIONS BY THE STATE AND IS IN NO WAY WARRANTED TO INDICATE THE TRUE CONDITIONS OR ACTUAL QUANTITIES OR DISTRIBUTION OF QUANTITIES OF WORK WHICH WILL BE REQUIRED.

CORE NO.	WATER SOLUBLE CHLORIDE CONTENT % BY WT.	LBS./CY.
1	0.054	2.117
3	0.065	2.548
5	0.147	5.762

(See Note 4 Str. Sht. Date 6/5/81)

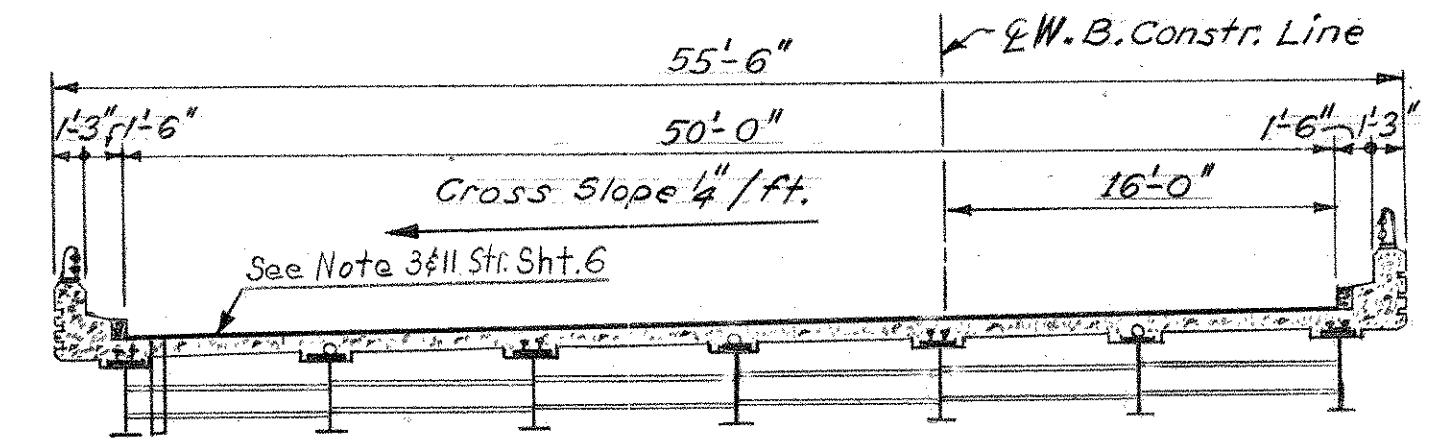

BRIDGE NO. 3171
 WEST BOUND ROADWAY BRIDGE SECTION
 Scale: 1/8" = 1'-0"

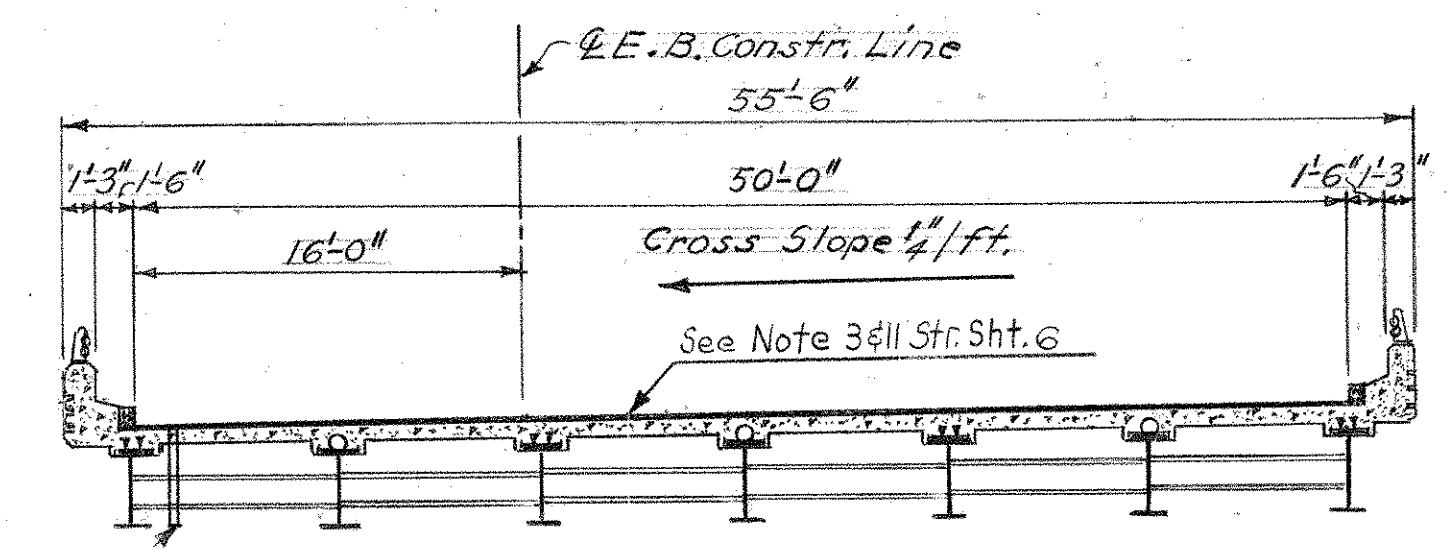

BRIDGE NO. 3170
 EASTBOUND ROADWAY BRIDGE SECTION
 Scale: 1/8" = 1'-0"

* Joint dimensions taken and deck condition survey done 5/81.

CORE NO.	CHLORIDE CONTENT (% BY WEIGHT)	CHLORIDE CONTENT (LBS./C.U. YD.)
1	0.076	2.979
1A	0.015	0.588
2	0.019	0.745
2A	0.005	0.196
3	0.067	2.626
3A	0.011	0.431
4	0.037	1.450
4A	0.006	0.235
5	0.154	6.037
5A	0.068	2.666
6	0.051	1.999
6A	0.040	1.568
7	0.021	0.823
7A	0.013	0.510
8	0.025	0.980
8A	0.015	0.588

(See Note 4 Str. Sht. 6 Date of tests 6/5/81)

Note: For Section 9-9, See Str. Sht. 86.
 For Section 11-11 See Str. Sht. 82.

CONNECTICUT
 DEPARTMENT OF TRANSPORTATION
 SOUTHINGTON - HARTFORD
 INTERSTATE ROUTE 84
 59 STRUCTURES
 DECK REPAIRS
 I-84 E.B. & W.B. OVER DEAN AVE.

ENGINEER BRIDGE DESIGN UNIT		
DESIGNER J.P.L.	DRAFTER G.O.K.	CHECKER G.D.B.
APPROVED <i>[Signature]</i>	DATE 3/17/82	
NO. DATE	DESCRIPTION	REVISIONS
STRUCTURE NO. 131-145-3171 & 3170	BRIDGE LOT NO. 3171-3170	STRUCTURE SHEET NO. 13 OF 87

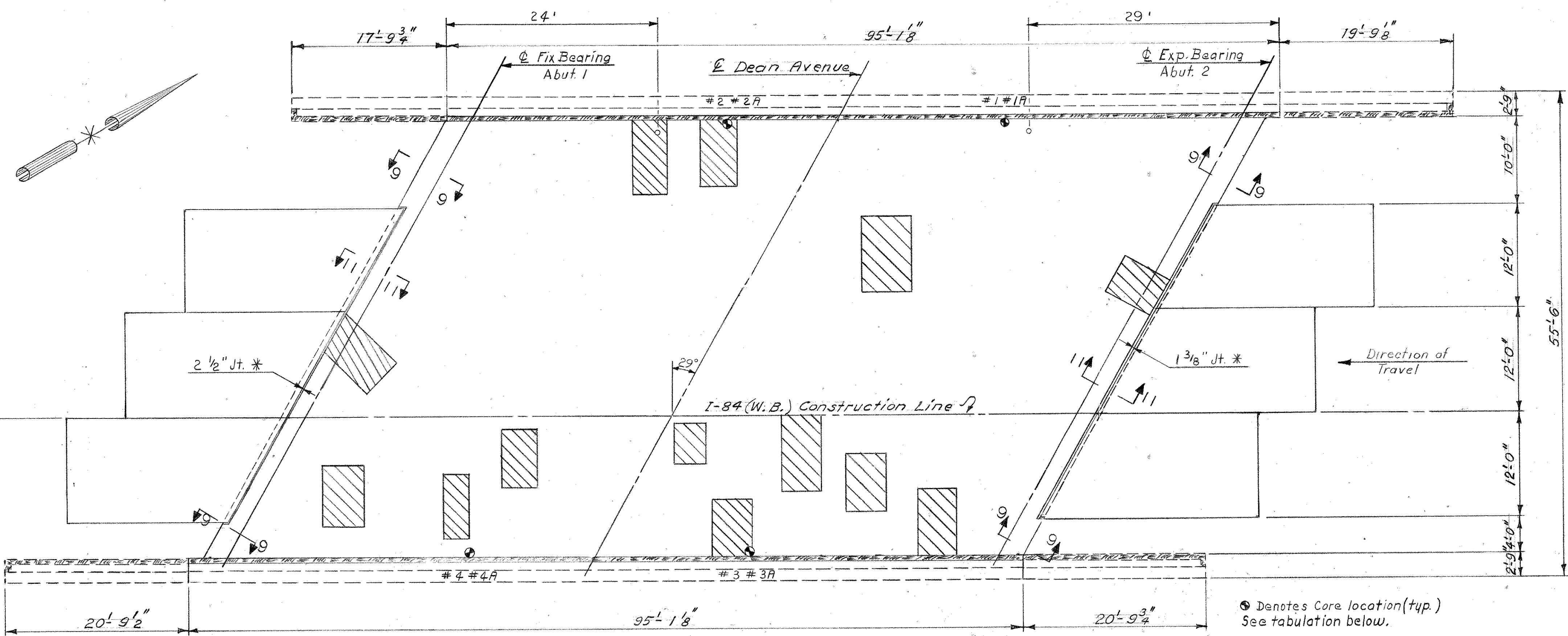

BRIDGE NO. 3171
 DECK PLAN - WESTBOUND BRIDGE
 Scale: 1/8" = 1'-0"

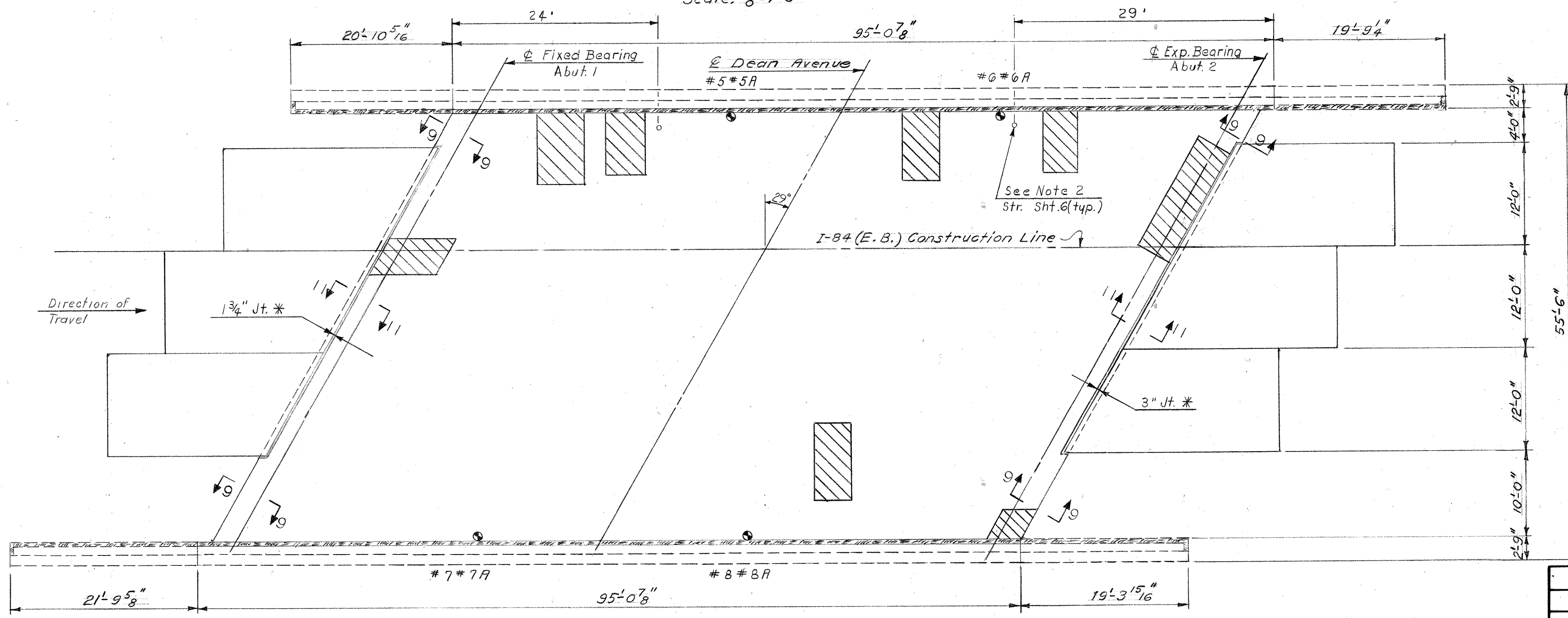

BRIDGE NO. 3170
 DECK PLAN - EASTBOUND BRIDGE
 Scale: 1/8" = 1'-0"

THE INFORMATION, INCLUDING ESTIMATED QUANTITIES OF WORK SHOWN ON THESE SHEETS IS BASED ON LIMITED INVESTIGATIONS BY THE STATE AND IS IN NO WAY WARRANTED TO INDICATE THE TRUE CONDITIONS OR ACTUAL QUANTITIES OR DISTRIBUTION OF QUANTITIES OF WORK WHICH WILL BE REQUIRED.

F.H.W.A. REGION	STATE	TOWN	FED. AID PROJ. NO.	PROJ. NO.	YEAR	ROUTE NO.	SHEET NO.	TOTAL SHEETS
1	CONN	Plainville	PRR-84-3(85)42	131-145	1982	84	27	115

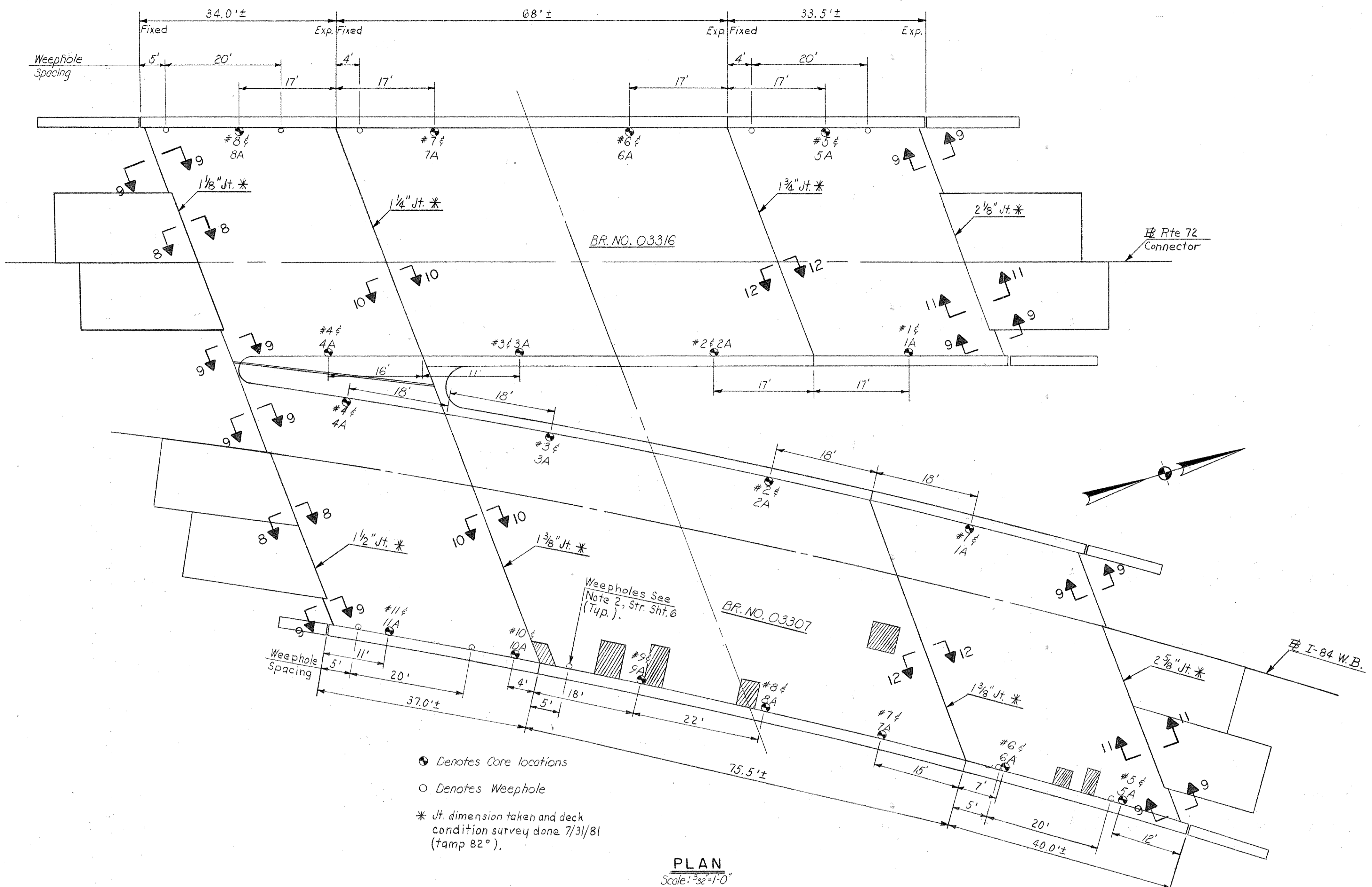

BRIDGE NO. 03316				
CORE NO.	CHLORIDE CONTENT		CHLORIDE CONTENT	
	TOTAL		WATER SOLUBLE	
	% BY WT.	LBS./C.Y.	% BY WT.	LBS./C.Y.
1	0.005	0.196	—	—
1A	0.001	0.039	—	—
2	0.004	0.157	—	—
2A	0.003	0.118	—	—
3	0.005	0.196	—	—
3A	0.005	0.196	—	—
4	0.004	0.157	—	—
4A	0.009	0.353	—	—
5	0.005	0.196	—	—
5A	0.004	0.157	—	—
6	0.007	0.274	—	—
6A	0.005	0.196	—	—
7	0.015	0.588	—	—
7A	0.007	0.274	—	—
8	0.010	0.392	—	—
8A	0.003	0.118	—	—

BRIDGE NO. 03307				
CORE NO.	CHLORIDE CONTENT		CHLORIDE CONTENT	
	TOTAL		WATER SOLUBLE	
	% BY WT.	LBS./C.Y.	% BY WT.	LBS./C.Y.
1	0.002	0.078	—	—
1A	0.001	0.039	—	—
2	0.031	1.215	0.026	1.019
2A	0.003	0.118	—	—
3	0.037	1.450	—	—
3A	0.003	0.118	—	—
4	0.002	0.078	—	—
4A	0.001	0.039	—	—
5	0.002	0.078	—	—
5A	0.001	0.039	—	—
6	0.003	0.118	—	—
6A	0.003	0.118	—	—
7	0.009	0.353	—	—
7A	0.001	0.039	—	—
8	0.008	0.314	—	—
8A	0.004	0.157	—	—
9	0.006	0.235	—	—
9A	0.003	0.118	—	—
10	0.009	0.353	—	—
10A	0.004	0.157	—	—
11	0.005	0.196	—	—
11A	0.004	0.157	—	—

NOTE: See note 4, str. sht. 6 for core tabulation notes.
 For sections 8-8, 9-9, & 10-10 see str. sht. 86.
 For sections 11-11 & 12-12 see str. sht. 82.

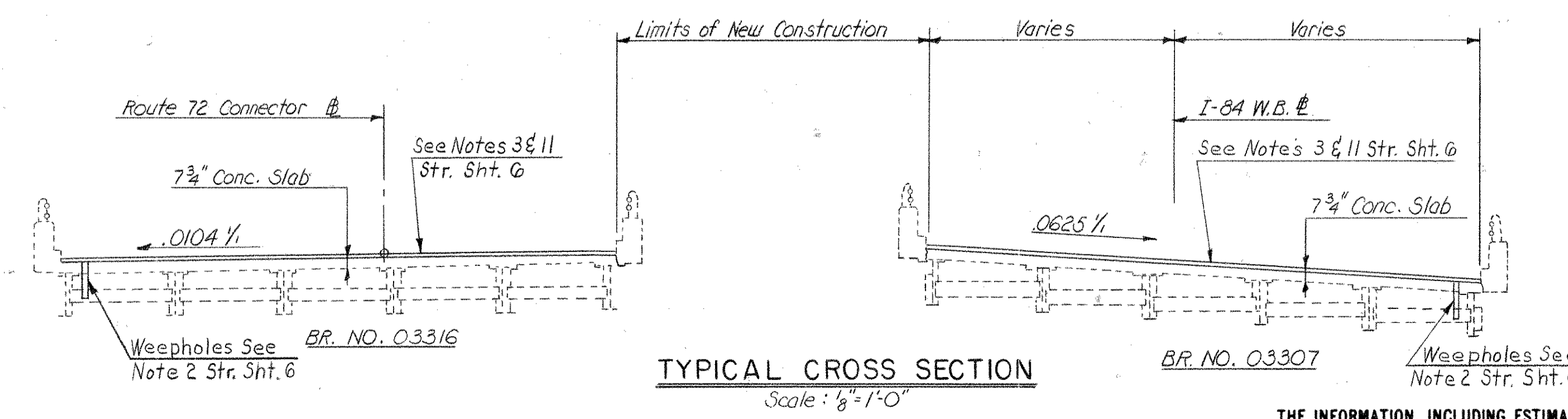

TYPICAL CROSS SECTION
 Scale: 1/4\"/>

THE INFORMATION, INCLUDING ESTIMATED QUANTITIES OF WORK SHOWN ON THESE SHEETS IS BASED ON LIMITED INVESTIGATIONS BY THE STATE AND IS IN NO WAY WARRANTED TO INDICATE THE TRUE CONDITIONS OR ACTUAL QUANTITIES OR DISTRIBUTION OF QUANTITIES OF WORK WHICH WILL BE REQUIRED.

CONNECTICUT
 DEPARTMENT OF TRANSPORTATION
 SOUTHTON-HARTFORD

INTERSTATE 84
 59 STRUCTURES
 DECK REPAIRS

I-84 W.B. & RTE 72 CONNECTOR OVER WOODFORD AVE

ENGINEER BRIDGE DESIGN UNIT		
DESIGNER G. D. B.	DRAFTER J. J. C.	CHECKER G. D. B.
APPROVED <i>[Signature]</i>	DATE 2/17/82	
NO. DATE	DESCRIPTION	REVISIONS
STRUCTURE NO. 131-145-3307&3316		BRIDGE LOG NO. 3307 & 3316
		STRUCTURE SHEET NO. 14 of 87

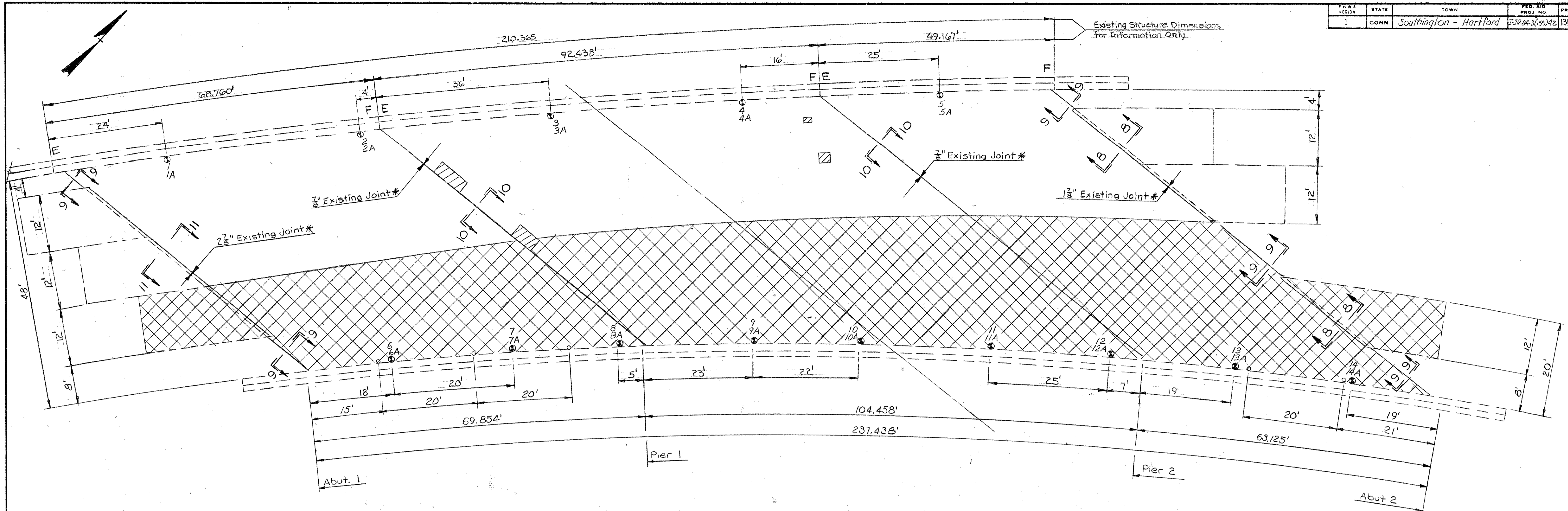

PLAN
Scale 3/32"=1'-0"

- NOTES:
- ⊙ Denotes Core location, see tabulations this sheet.
 - ▨ Existing Bituminous Concrete Wearing Surface to be removed. See Note 5, Str. Sht. 6.
 - Denotes Weephole location.
 - * Joint dimensions and deck condition survey done in July 1981. Temp. 86°.

CORE NO.	CHLORIDE CONTENT (% By Weight)	CHLORIDE CONTENT (lb/cu. yd.)
1	0.069	2.705
1A	0.031	1.215
2	0.003	0.118
2A	0.003	0.118
3	0.003	0.118
3A	0.002	0.078
4	0.034	1.333
4A	0.004	0.157
5	0.002	0.078
5A	None	None
6	0.074	2.901
6A	0.015	0.588
7	0.005	0.196
7A	0.005	0.196
8	0.007	0.274
8A	0.004	0.157
9	0.031	1.215
9A	0.007	0.274
10	0.005	0.196
10A	0.004	0.157
11	0.004	0.157
11A	0.004	0.157
12	0.003	0.118
12A	0.003	0.118
13	0.005	0.196
13A	0.004	0.157
14	0.002	0.078
14A	0.002	0.078

CORE TABULATION NOTES
The Suffix 'A' on the core numbers indicates these samples were taken 4" below the surface of the deck. All other samples were taken 1 1/2" below the deck.
The Chloride content data shown was determined from samples taken between August 1981 and September 1981. It is tabulated for information and documentation purposes only.

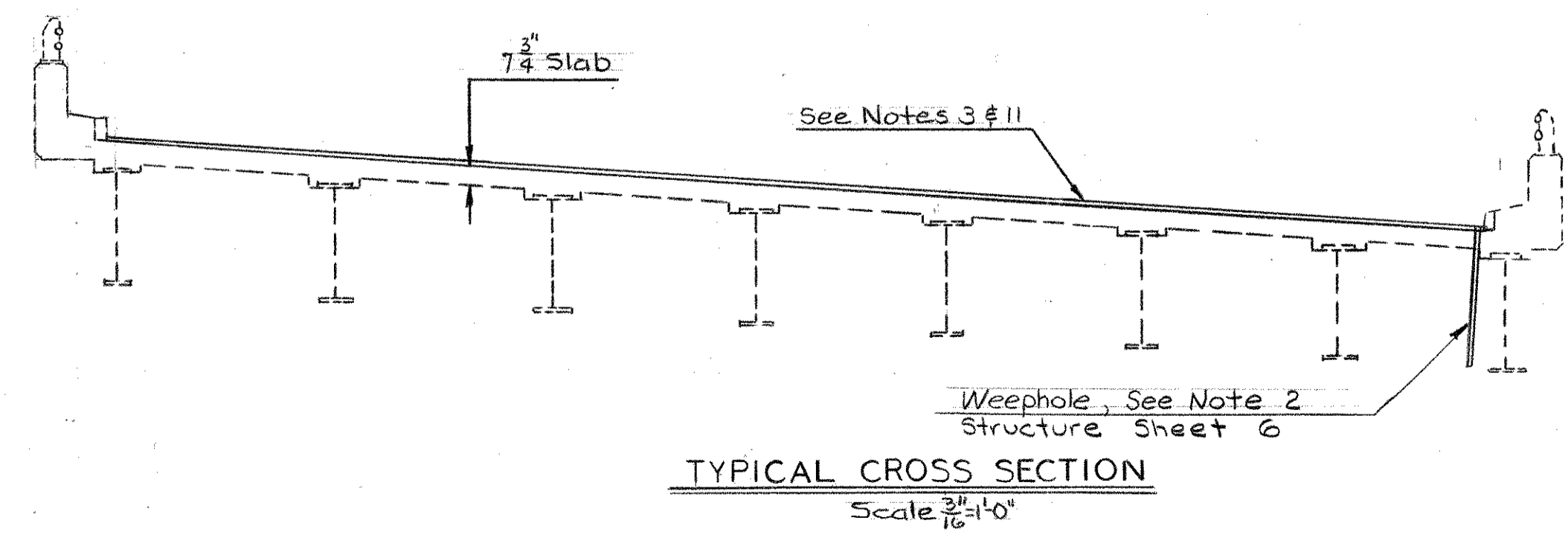

TYPICAL CROSS SECTION
Scale 3/16"=1'-0"

CONNECTICUT
DEPARTMENT OF TRANSPORTATION
SOUTHINGTON - HARTFORD
INTERSTATE ROUTE 84
59 STRUCTURES
DECK REPAIRS
I-84 EASTBOUND OVER WOODFORD AVE.

ENGINEER Bridge Design Unit	
DESIGNER G.J.A.	DRAFTER F.T.R.
CHECKER G.D.B.	DATE 3/17/82
APPROVED <i>[Signature]</i>	BRIDGE LOG NO. 3308
STRUCTURE NO. 131-145-3308	STRUCTURE SHEET NO. 15 OF 87

THE INFORMATION, INCLUDING ESTIMATED QUANTITIES OF WORK SHOWN ON THESE SHEETS IS BASED ON LIMITED INVESTIGATIONS BY THE STATE AND IS IN NO WAY WARRANTED TO INDICATE THE TRUE CONDITIONS OR ACTUAL QUANTITIES OR DISTRIBUTION OF QUANTITIES OF WORK WHICH WILL BE REQUIRED.

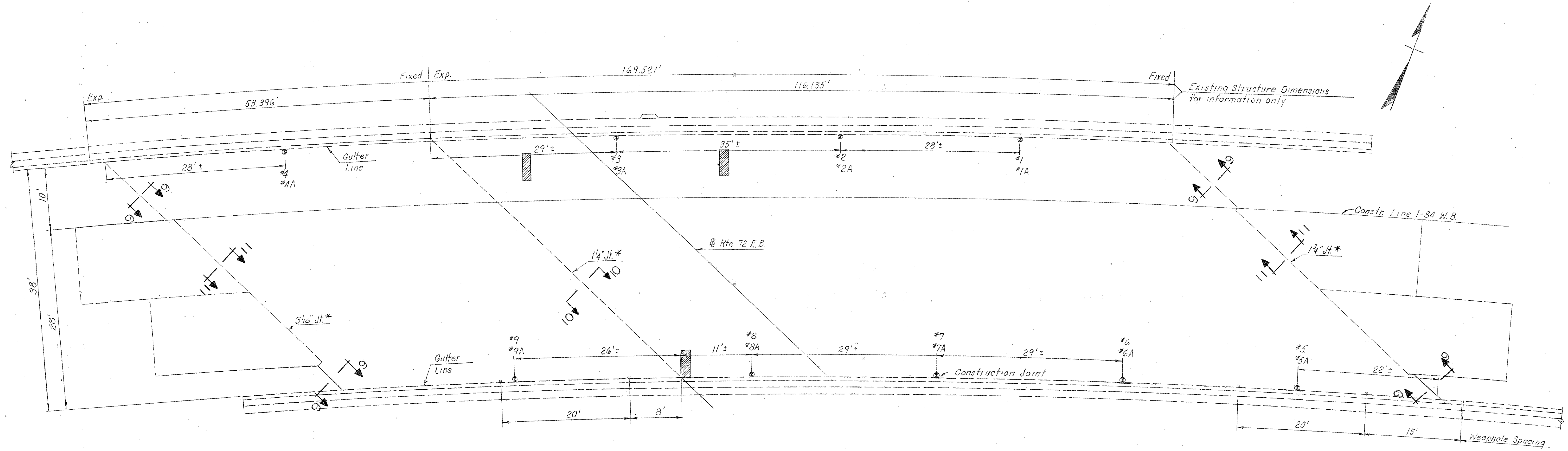

PLAN
Scale 1/8"=1'-0"

⊙ Denotes Core locations, see tabulations this sheet.
* Jt. dimensions taken and Deck Survey done 7/31/81 (Temp 82°).

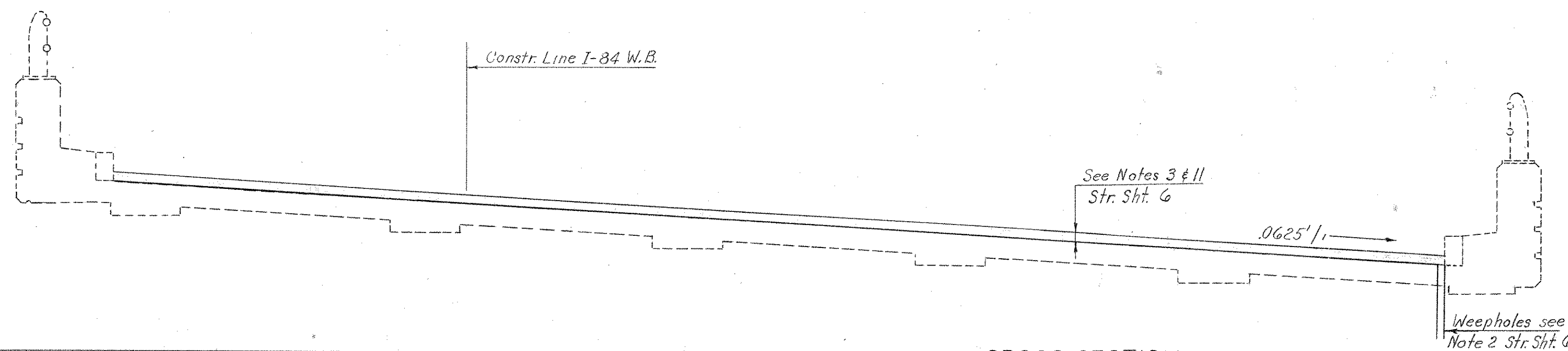

CROSS SECTION
Scale 3/8"=1'-0"

Note: For Sections 9-9 & 10-10 see Str. Sht. 86.
For Section 11-11, see Str. Sht. 82.

CORE NO.	CHLORIDE CONTENT (% by weight)	CHLORIDE CONTENT (lbs. per C.Y.)	CORE NO.	CHLORIDE CONTENT (% by weight)	CHLORIDE CONTENT (lbs. per C.Y.)
1	0.014	0.549	6	0.004	0.157
1A	0.002	0.078	6A	0.002	0.078
2	0.003	0.118	7	0.004	0.157
2A	0.003	0.118	7A	0.003	0.118
3	0.005	0.196	8	0.013	0.560
3A	0.004	0.157	8A	0.003	0.118
4	0.001	0.039	9	0.004	0.157
4A	0.002	0.078	9A	0.004	0.157
5	0.004	0.157			
5A	0.003	0.118			

See Note 4, Str. Sht. 6 for Chloride Tabulation Notes

THE INFORMATION, INCLUDING ESTIMATED QUANTITIES OF WORK SHOWN ON THESE SHEETS IS BASED ON LIMITED INVESTIGATIONS BY THE STATE AND IS IN NO WAY WARRANTED TO INDICATE THE TRUE CONDITIONS OR ACTUAL QUANTITIES OR DISTRIBUTION OF QUANTITIES OF WORK WHICH WILL BE REQUIRED.

CONNECTICUT			
DEPARTMENT OF TRANSPORTATION			
SOUTHINGTON-HARTFORD			
INTERSTATE 84			
59 STRUCTURES			
DECK REPAIRS			
I-84 W.B. OVER RTE. 72 E.B.			
ENGINEER		BRIDGE DESIGN UNIT	
DESIGNER	J.P.B.	DRAFTER	T.S.R.
CHECKER	G.D.B.	DATE	3/17/82
NO.	DATE	DESCRIPTION	APPROVED
REVISIONS		STRUCTURE NO.	131-145-3309
		BRIDGE LOG NO.	3309
		STRUCTURE SHEET NO.	16 of 87

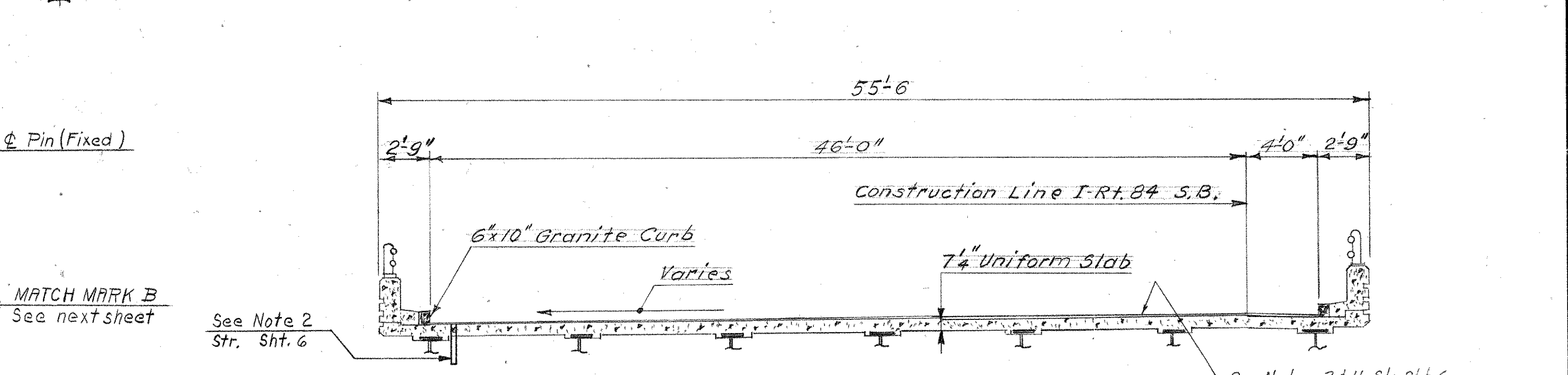
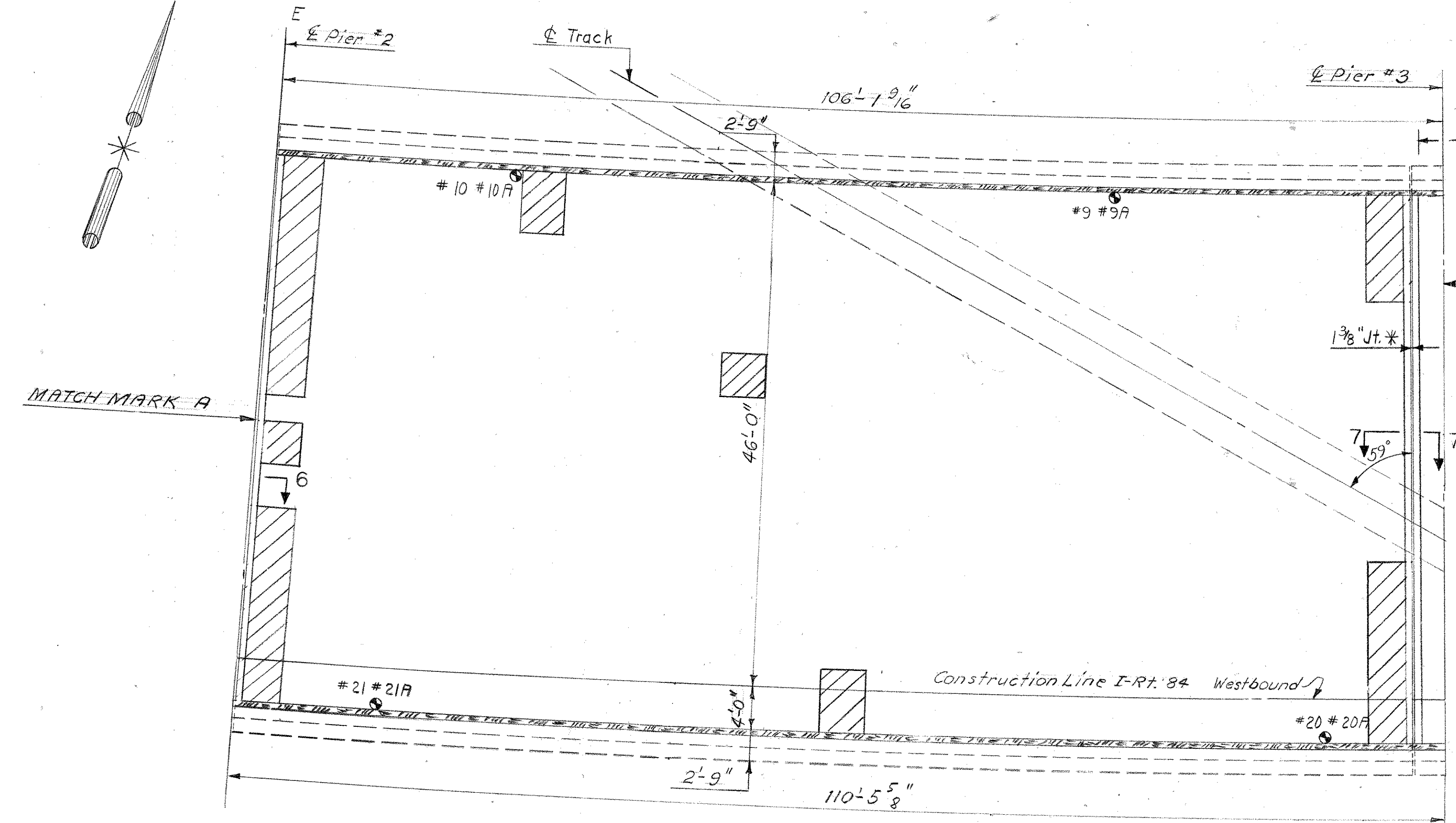
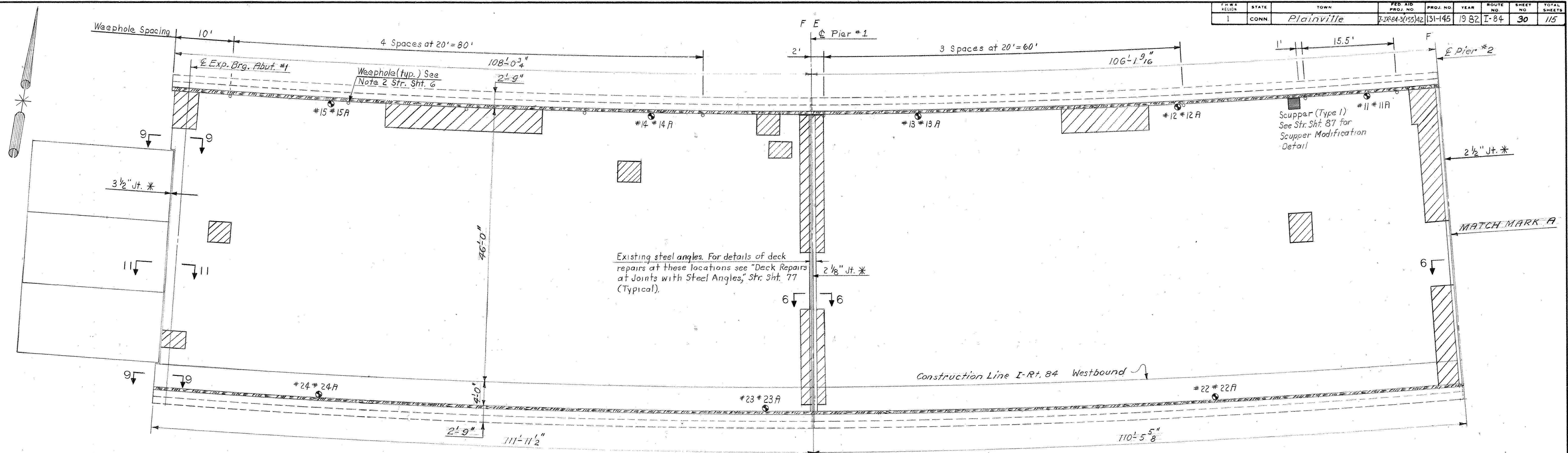

CORE NO.	CHLORIDE CONTENT (% BY WEIGHT)	CHLORIDE CONTENT (LBS. / CU YD)
9	0.016	0.627
9A	0.026	1.019
10	0.062	2.430
10A	0.022	0.862
11	0.035	1.372
11A	0.020	0.784
12	0.119	4.665
12A	0.024	0.941
13	0.044	1.725
13A	0.046	1.803
14	0.045	1.764
14A	0.005	0.196
15	0.054	2.117
15A	0.023	0.902
20	0.017	0.666
20A	0.016	0.627
21	0.039	1.529
21A	0.009	0.353
22	0.015	0.588
22A	0.023	0.902
23	0.143	5.606
23A	0.031	1.215
24	0.022	0.862
24A	0.017	0.666

CORE NO.	WATER SOLUBLE CHLORIDE CONTENT (% BY WT.)	LBS. / C.Y.
12	0.096	3.765
23	0.105	4.116

The information, including estimated quantities of work shown on these sheets is based on limited investigations by the State and is in no way warranted to indicate the true conditions or actual quantities or distribution of quantities of work which will be required.

DECK PLAN-BRIDGE NO. 3311
Scale: 1/8" = 1'-0"

• Denotes Core Location

CONNECTICUT
DEPARTMENT OF TRANSPORTATION

SOUTHINGTON - HARTFORD

INTERSTATE ROUTE 84

59 STRUCTURES

DECK REPAIRS

I-84 W.B. OVER RT. 372, R.R. & QUINNIPIAC RIVER

ENGINEER BRIDGE DESIGN UNIT

DESIGNER J.P.L.	DRAFTER G.O.K.	CHECKER G.D.B.
APPROVED <i>[Signature]</i>	DATE 3/17/82	

STRUCTURE NO. 131-145-3311

BRIDGE LOG NO. 3311

STRUCTURE SHEET NO. 17 of 87

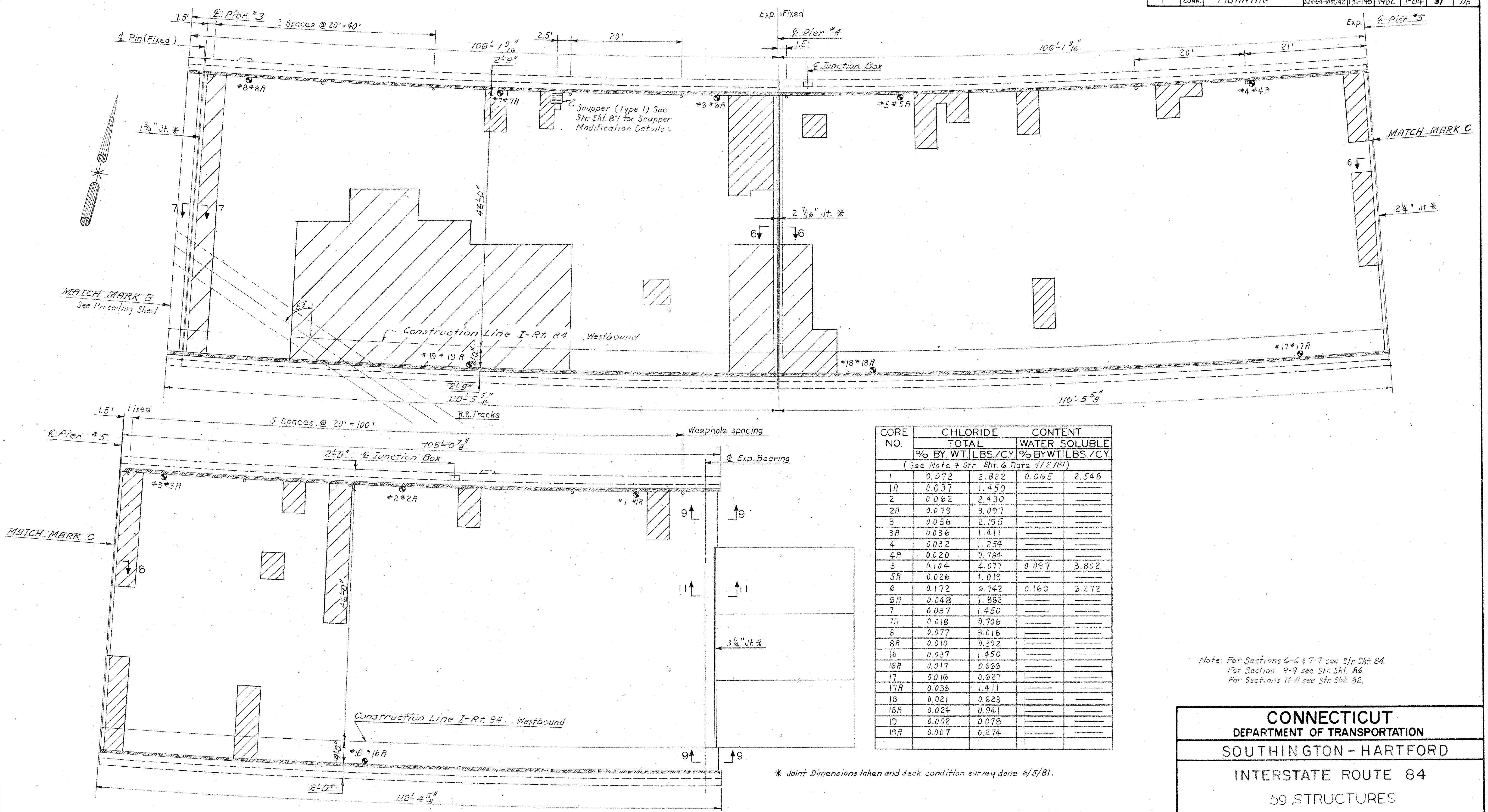

CORE NO.	CHLORIDE TOTAL		CONTENT WATER SOLUBLE	
	% BY WT.	LBS./CY	% BY WT.	LBS./CY
1	0.072	2.822	0.065	2.548
1A	0.037	1.450		
2	0.062	2.430		
2A	0.079	3.097		
3	0.056	2.195		
3A	0.036	1.411		
4	0.032	1.254		
4A	0.020	0.784		
5	0.104	4.077	0.097	3.802
5A	0.026	1.019		
6	0.172	6.742	0.160	6.272
6A	0.048	1.882		
7	0.037	1.450		
7A	0.018	0.706		
8	0.077	3.018		
8A	0.010	0.392		
16	0.037	1.450		
16A	0.017	0.666		
17	0.016	0.627		
17A	0.036	1.411		
18	0.021	0.823		
18A	0.024	0.941		
19	0.002	0.078		
19A	0.007	0.274		

Note: For Sections 6-6 & 7-7 see Str. Sht. 84.
 For Section 9-9 see Str. Sht. 86.
 For Sections 11-11 see Str. Sht. 82.

* Joint Dimensions taken and deck condition survey done 6/5/81.

DECK PLAN - BRIDGE NO. 3311
 Scale: 1/8" = 1'-0"

⊙ Denotes Core Location

THE INFORMATION, INCLUDING ESTIMATED QUANTITIES OF WORK SHOWN ON THESE SHEETS IS BASED ON LIMITED INVESTIGATIONS BY THE STATE AND IS IN NO WAY WARRANTED TO INDICATE THE TRUE CONDITIONS OR ACTUAL QUANTITIES OR DISTRIBUTION OF QUANTITIES OF WORK WHICH WILL BE REQUIRED.

CONNECTICUT
 DEPARTMENT OF TRANSPORTATION
 SOUTHBINGTON - HARTFORD
 INTERSTATE ROUTE 84
 59 STRUCTURES
 DECK REPAIRS

I-84 W.B. OVER RT. 372, R.R. & QUINNIPIAC RIVER

ENGINEER BRIDGE DESIGN UNIT
 DESIGNER J.P.L. DRAFTER G.O.K. CHECKER G.D.B.

APPROVED *[Signature]* DATE 3/17/82

REVISIONS STRUCTURE NO. 131-145-3311 BRIDGE LOG NO. 3311 STRUCTURE SHEET NO. 18 of 87

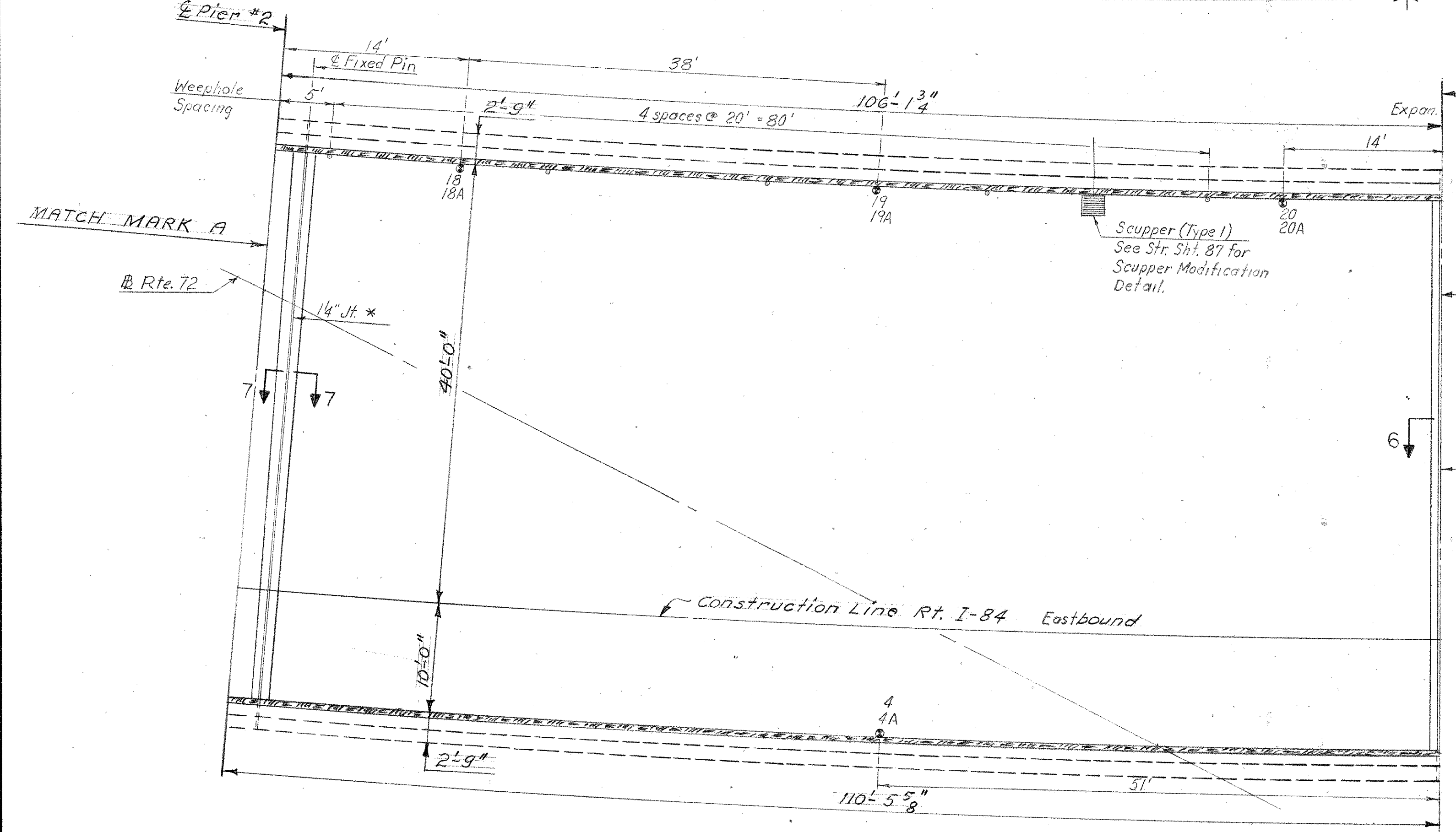
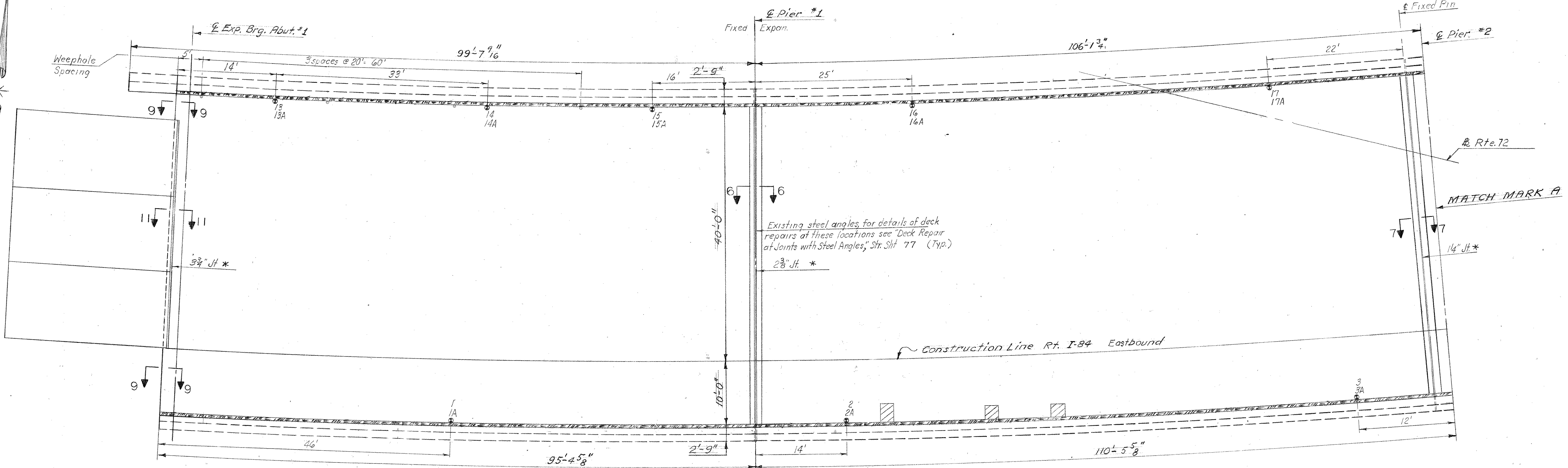

DECK PLAN - BRIDGE NO. 3312
Scale: 1/8" = 1'-0"

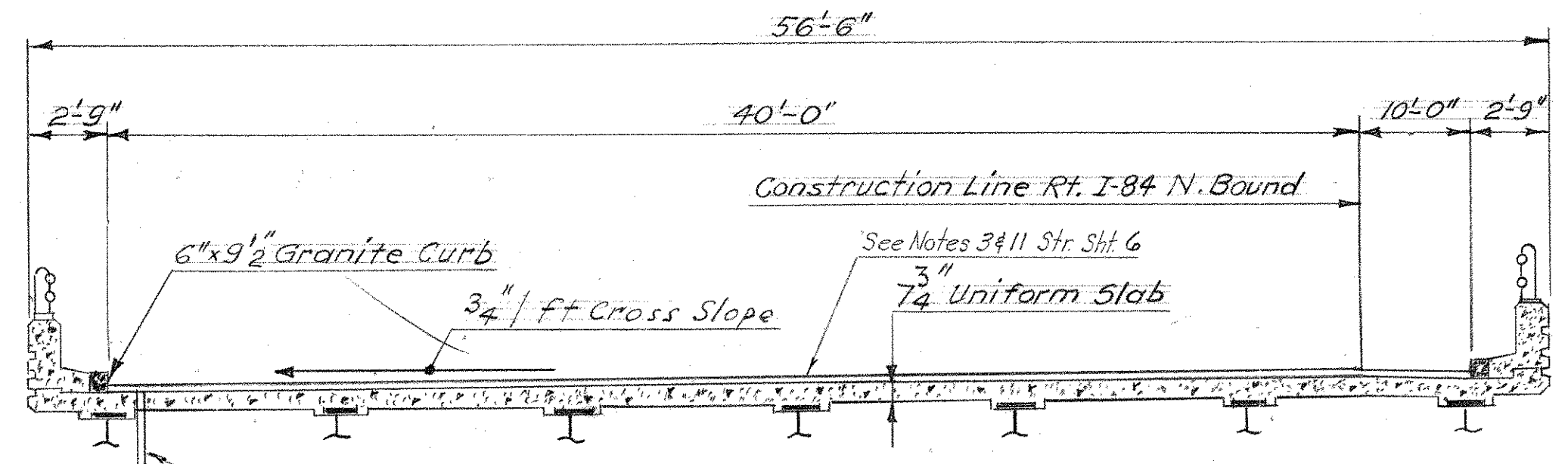

BRIDGE NO. 3312
TYPICAL BRIDGE SECTION
Scale: 3/16" = 1'-0"

* Denotes Core Location
* Jt. dimensions taken 6/4/81
Deck condition survey done 6/4/81

Notes: For Sections 6-6 & 7-7 see Str. Sht. 84.
For Section 9-9 see Str. Sht. 86.
For Section 11-11 see Str. Sht. 82.

THE INFORMATION, INCLUDING ESTIMATED QUANTITIES OF WORK SHOWN ON THESE SHEETS IS BASED ON LIMITED INVESTIGATIONS BY THE STATE AND IS IN NO WAY WARRANTED TO INDICATE THE TRUE CONDITIONS OR ACTUAL QUANTITIES OR DISTRIBUTION OF QUANTITIES OF WORK WHICH WILL BE REQUIRED.

CONNECTICUT			
DEPARTMENT OF TRANSPORTATION			
SOUTHINGTON - HARTFORD			
INTERSTATE ROUTE 84			
59 STRUCTURES			
DECK REPAIRS			
I-84 E.B. OVER RTE. 72 & R.R.			
ENGINEER BRIDGE DESIGN UNIT			
DESIGNER J.P.L.		DRAFTER G.O.K.	
CHECKER G.D.B.		DATE 3/17/82	
NO.	DATE	DESCRIPTION	APPROVED
REVISIONS		STRUCTURE NO. 131-145-3312	BRIDGE LOG NO. 3312
		STRUCTURE SHEET NO. 19 of 87	

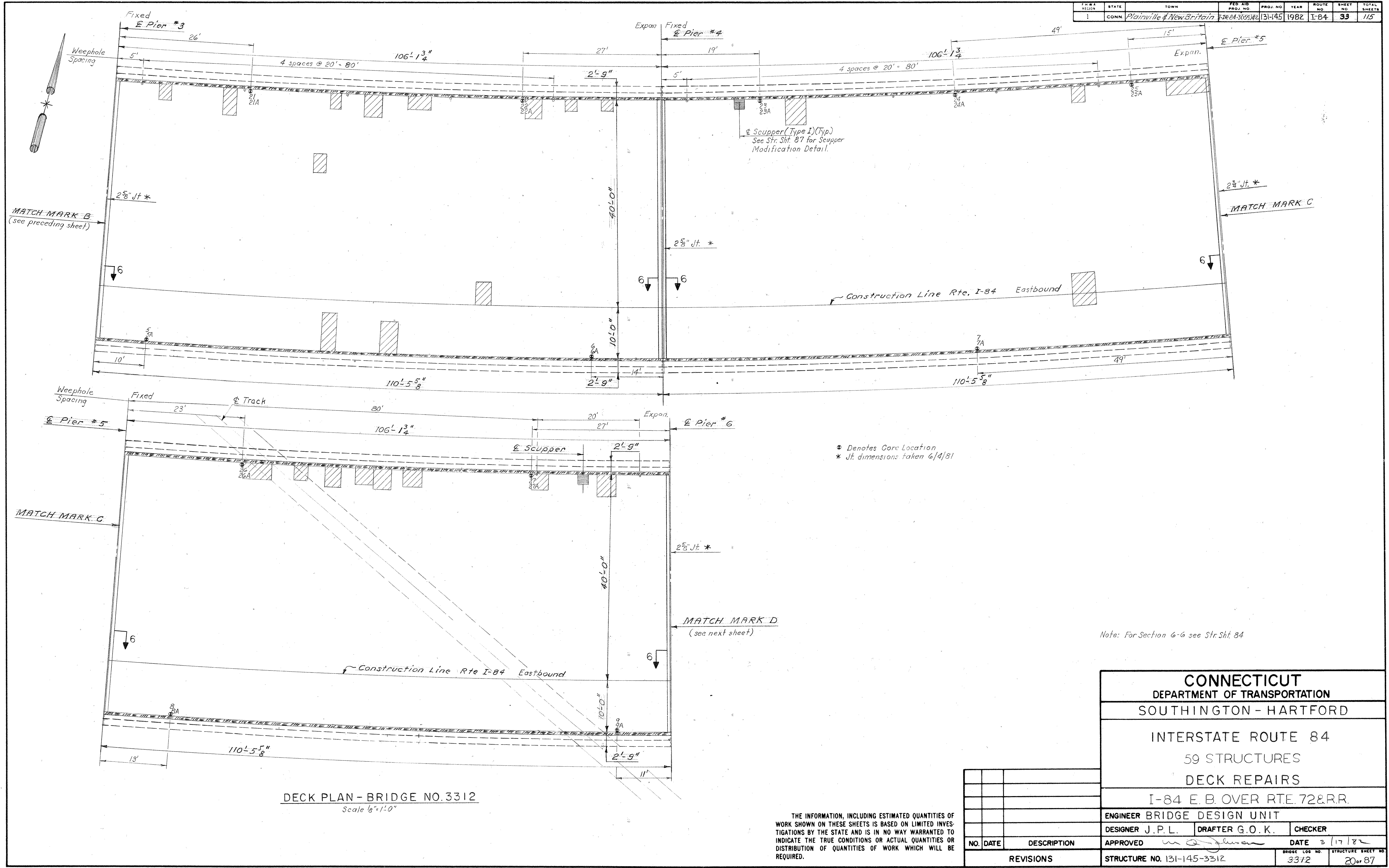

DECK PLAN - BRIDGE NO. 3312
Scale 1/8" = 1'-0"

⊙ Denotes Core Location
* Jt. dimensions taken 6/4/81

Note: For Section 6-6 see Str. Sht. 84

CONNECTICUT DEPARTMENT OF TRANSPORTATION SOUTHRINGTON - HARTFORD INTERSTATE ROUTE 84 59 STRUCTURES DECK REPAIRS I-84 E. B. OVER RTE. 72&R.R.		
ENGINEER BRIDGE DESIGN UNIT		
DESIGNER J. P. L.	DRAFTER G. O. K.	CHECKER
APPROVED <i>[Signature]</i>	DATE 3/17/82	
NO. DATE	DESCRIPTION	REVISIONS
STRUCTURE NO. 131-145-3312		BRIDGE LOG NO. 3312
		STRUCTURE SHEET NO. 20 of 87

THE INFORMATION, INCLUDING ESTIMATED QUANTITIES OF WORK SHOWN ON THESE SHEETS IS BASED ON LIMITED INVESTIGATIONS BY THE STATE AND IS IN NO WAY WARRANTED TO INDICATE THE TRUE CONDITIONS OR ACTUAL QUANTITIES OR DISTRIBUTION OF QUANTITIES OF WORK WHICH WILL BE REQUIRED.

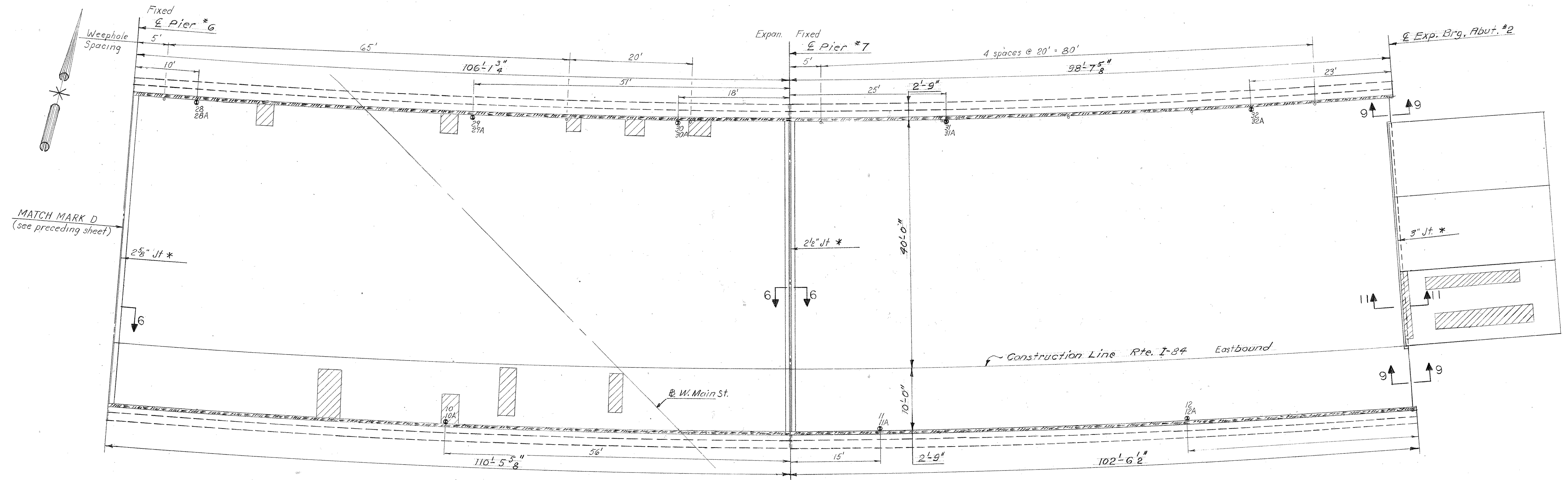

DECK PLAN - BRIDGE NO. 3312
Scale 1/8" = 1'-0"

* Denotes Core location
* Jt. dimensions taken 6/4/81

CORE NO.	CHLORIDE CONTENT			
	TOTAL	WATER SOLUBLE		
	% BY WT. LBS./CY.	% BY WT. LBS./CY.		
1	0.029	1.137		
1A	0.016	0.627		
2	0.098	3.842	0.090	3.528
2A	0.024	0.941		
3	0.027	1.058		
3A	0.118	4.626	0.048	1.882
4	0.057	2.234		
4A	0.026	1.019		
5	0.030	1.176		
5A	0.023	0.902		
6	0.016	0.627		
6A	0.026	1.019		
7	0.134	5.253	0.095	3.724
7A	0.025	0.980		
8	0.026	1.019		
8A	0.007	0.274		
9	0.046	1.803		
9A	0.029	1.137		
10	0.017	0.666		
10A	0.010	0.392		
11	0.014	0.549		
11A	0.005	0.196		

CORE NO.	CHLORIDE CONTENT			
	TOTAL	WATER SOLUBLE		
	% BY WT. LBS./CY.	% BY WT. LBS./CY.		
Cores continued				
12	0.012	0.470		
12A	0.009	0.353		
13	0.040	1.568		
13A	0.016	0.627		
14	0.020	0.784		
14A	0.026	1.019		
15	0.074	2.901	0.041	1.607
15A	0.026	1.019		
16	0.037	1.450		
16A	0.039	1.529		
17	0.053	2.078		
17A	0.015	0.588		
18	0.028	1.098		
18A	0.022	0.862		
19	0.016	0.627		
19A	0.033	1.294		
20	0.048	1.882		
20A	0.020	0.784		
21	0.019	0.745		
21A	0.021	0.823		
22	0.044	1.725		
22A	0.022	0.862		

CORE NO.	CHLORIDE CONTENT			
	TOTAL	WATER SOLUBLE		
	% BY WT. LBS./CY.	% BY WT. LBS./CY.		
Cores continued				
23	0.023	0.902		
23A	0.018	0.706		
24	0.021	0.823		
24A	0.020	0.784		
25	0.024	0.941		
25A	0.018	0.706		
26	0.032	1.254		
26A	0.024	0.941		
27	0.018	0.706		
27A	0.021	0.823		
28	0.021	0.823		
28A	0.019	0.745		
29	0.036	3.371	0.081	3.175
29A	0.055	2.156		
30	0.006	0.235		
30A	0.004	0.157		
31	0.028	1.098		
31A	0.007	0.274		
32	0.011	0.431		
32A	0.005	0.196		

Notes: For Section 6-6 See Str. 84
For Section 9-9 See Str. 86
For Section 11-11 See Str. 82.

CONNECTICUT			
DEPARTMENT OF TRANSPORTATION			
SOUTHINGTON - HARTFORD			
INTERSTATE ROUTE 84			
59 STRUCTURES			
DECK REPAIRS			
I-84 E.B. OVER RTE. 72 & RR.			
ENGINEER BRIDGE DESIGN UNIT			
DESIGNER J.P.L.		DRAFTER G.O.K.	CHECKER G.D.B.
APPROVED <i>[Signature]</i>		DATE 3/17/82	
NO. DATE DESCRIPTION		STRUCTURE NO. 131-145-3312	
REVISIONS		BRIDGE LOG NO. 3312	STRUCTURE SHEET NO. 21 of 87

THE INFORMATION, INCLUDING ESTIMATED QUANTITIES OF WORK SHOWN ON THESE SHEETS IS BASED ON LIMITED INVESTIGATIONS BY THE STATE AND IS IN NO WAY WARRANTED TO INDICATE THE TRUE CONDITIONS OR ACTUAL QUANTITIES OR DISTRIBUTION OF QUANTITIES OF WORK WHICH WILL BE REQUIRED.

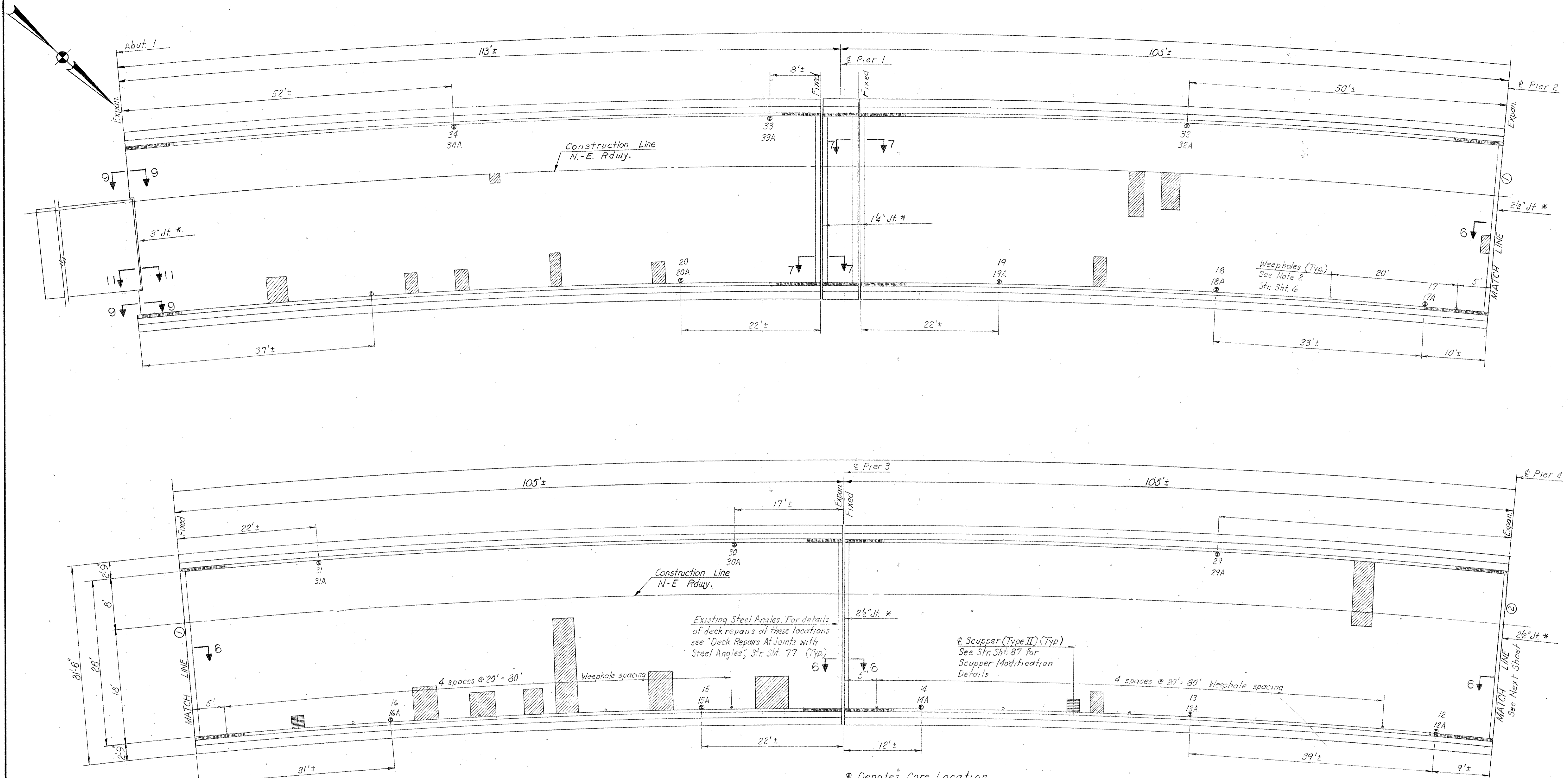

N-E RDWY. (I-84 TO RELOC. RTE. 72)
 OVER
 RELOC. RTE. 72 (W.B.) QUINNIPIAC RIVER,
 N.Y., N.H. & H.R.R., RELOC. WEST MAIN ST.,
 & I-84 (N.B.)
 Scale 1/8" = 1'-0"

Note: For Sections 6-6 & 7-7 see Str. Sht. 84.
 For Section 9-9 see Str. Sht. 86.
 For Section 11-11 see Str. Sht. 82.

• Denotes Core Location
 * Jt dimensions taken 6/17/81
 Deck condition survey done 6/17/81.

CONNECTICUT			
DEPARTMENT OF TRANSPORTATION			
SOUTHINGTON - HARTFORD			
INTERSTATE ROUTE 84			
59 STRUCTURES			
DECK REPAIRS			
E.B.OFF RAMP OVER WBI-84 & WB RT. 72			
ENGINEER BRIDGE DESIGN UNIT			
DESIGNER J.P.L.	DRAFTER J.J.C.	CHECKER G.D.B.	
NO. DATE	DESCRIPTION	APPROVED <i>[Signature]</i>	DATE 3/17/82
REVISIONS		STRUCTURE NO. 131-145-3313	BRIDGE LOG NO. 3313
		STRUCTURE SHEET NO. 22 of 87	

THE INFORMATION, INCLUDING ESTIMATED QUANTITIES OF WORK SHOWN ON THESE SHEETS IS BASED ON LIMITED INVESTIGATIONS BY THE STATE AND IS IN NO WAY WARRANTED TO INDICATE THE TRUE CONDITIONS OR ACTUAL QUANTITIES OR DISTRIBUTION OF QUANTITIES OF WORK WHICH WILL BE REQUIRED.

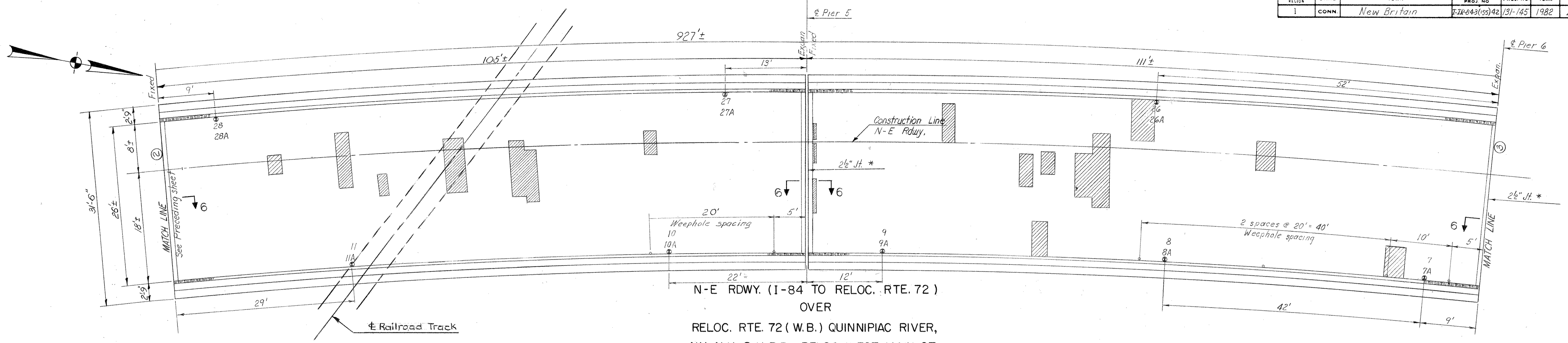

N-E RDWY. (I-84 TO RELOC. RTE. 72)
OVER
RELOC. RTE. 72 (W.B.) QUINNIAC RIVER,
N.Y., N.H. & H.R.R., RELOC. WEST MAIN ST.,
8 I-84 (N.B.)
Scale 6" = 1'-0"

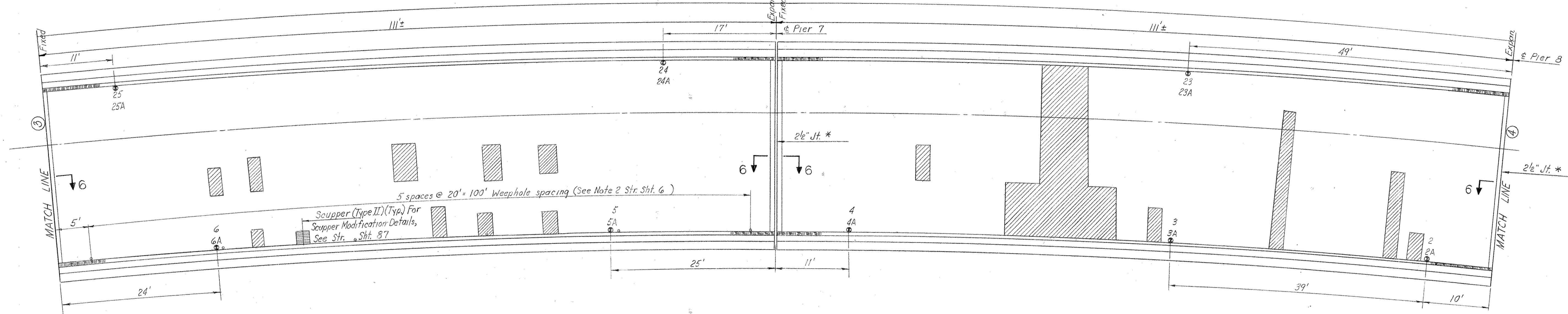

• Denotes Core Location
* Joint Dimensions Taken and Deck Condition Survey done 6-17-81.

Note: For Section 6-6 see Str. Sht. 84.
For Section 9-9 see Str. Sht. 86.
For Section 11-11 see Str. Sht. 82.

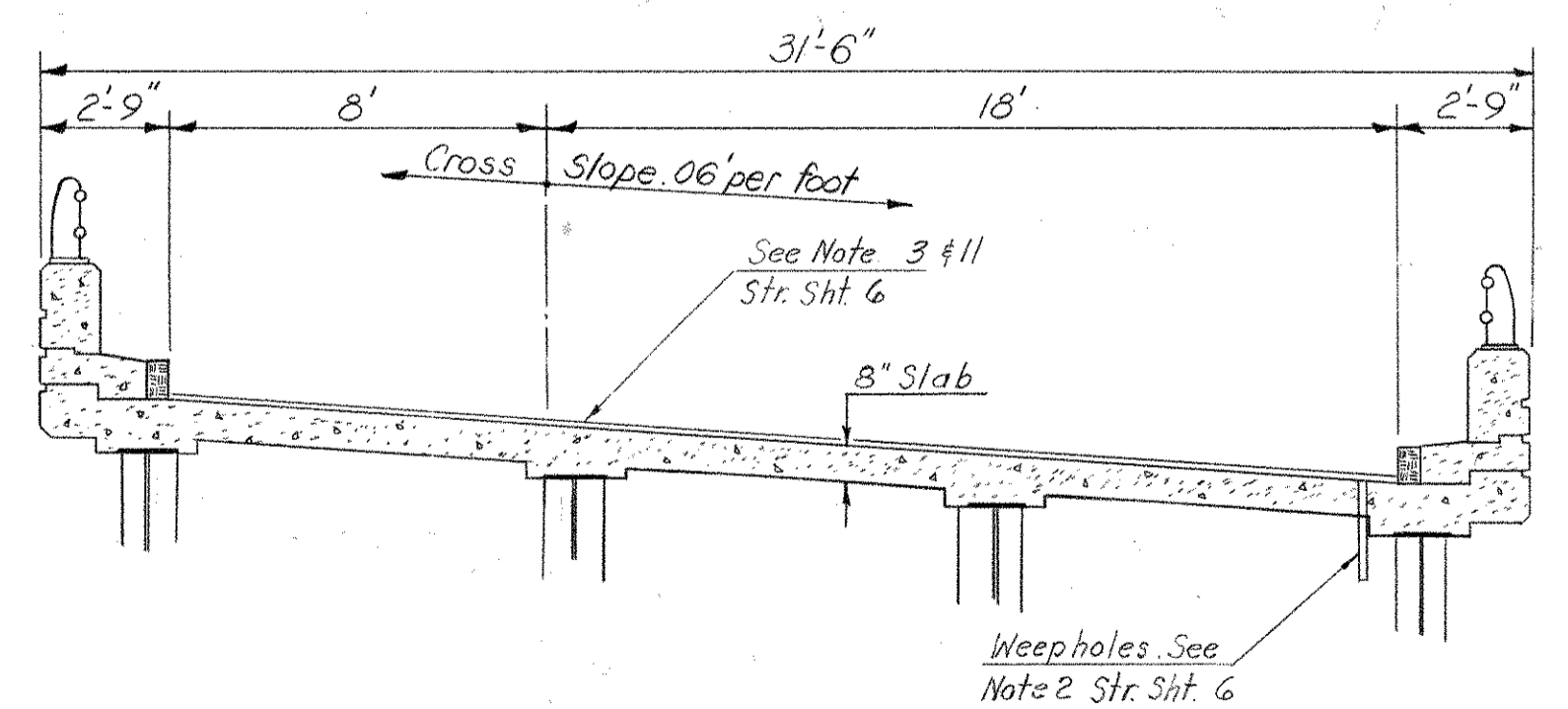

TYPICAL BRIDGE CROSS SECTION
Scale 4" = 1'-0"

THE INFORMATION, INCLUDING ESTIMATED QUANTITIES OF WORK SHOWN ON THESE SHEETS IS BASED ON LIMITED INVESTIGATIONS BY THE STATE AND IS IN NO WAY WARRANTED TO INDICATE THE TRUE CONDITIONS OR ACTUAL QUANTITIES OR DISTRIBUTION OF QUANTITIES OF WORK WHICH WILL BE REQUIRED.

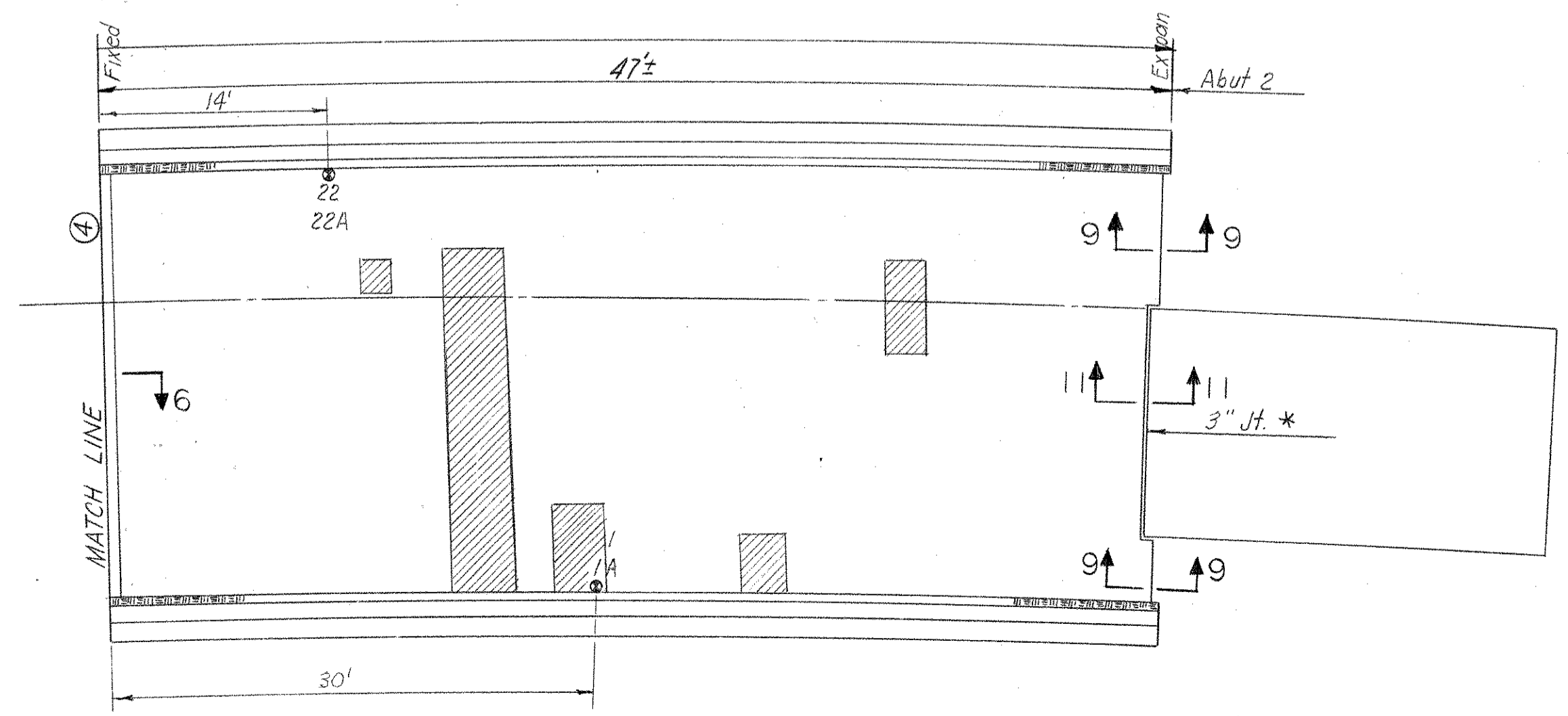

CONNECTICUT			
DEPARTMENT OF TRANSPORTATION			
SOUTHINGTON - HARTFORD			
INTERSTATE ROUTE 84			
59 STRUCTURES			
DECK REPAIRS			
E.B. OFF RAMP OVER W.B. I-84 & W.B. RT. 72			
ENGINEER BRIDGE DESIGN UNIT			
DESIGNER	J.P.L.	DRAFTER	J.J.C.
CHECKER	G.D.B.		
NO.	DATE	DESCRIPTION	APPROVED
			DATE 7/17/82
REVISIONS		STRUCTURE NO. 131-145-3313	BRIDGE LOG NO. 3313
			STRUCTURE SHEET NO. 23087

BR. NO. 3320				
CORE NO.	CHLORIDE CONTENT			
	TOTAL	WATER SOLUBLE		
	% BY WT. LBS./CY	% BY WT. LBS./CY		
(See Note 4 Str. Sht. 6 Date 6/26/81)				
1	0.077	3.018		
1A	0.042	1.646		
2	0.147	5.762	0.140	5.488
2A	0.089	3.489		
3	0.018	0.706		
3A	0.006	0.235		
4	0.091	3.567	0.089	3.483
4A	0.019	0.745		
5	0.025	0.980		
5A	0.007	0.274		
6	0.067	2.626		
6A	0.015	0.588		
7	0.027	1.058		
7A	0.010	0.392		
8	0.060	2.352		
8A	0.020	0.784		
9	0.065	2.548		
9A	0.054	2.117		
10	0.083	3.254	0.054	2.117
10A	0.071	2.783		
11	0.080	3.136		
11A	0.019	0.745		
12	0.055	2.156		
12A	0.004	0.157		

BR. NO. 03313				
CORE NO.	CHLORIDE CONTENT			
	TOTAL	WATER SOLUBLE		
	% BY WT. LBS./CY	% BY WT. LBS./CY		
(See Note 4 Br. Sht. 6 Date 7/16/81)				
1	0.100	3.920		
1A	0.080	3.136		
2	0.130	5.096	0.123	4.822
2A	0.091	3.567		
3	0.109	4.273		
3A	0.022	0.862		
4	0.132	5.174		
4A	0.024	0.941		
5	0.184	7.213	0.161	6.311
5A	0.105	4.116		
6	0.189	7.409	0.178	6.978
6A	0.157	6.154		
7	0.165	6.468		
7A	0.087	3.410		
8	0.107	4.194		
8A	0.086	3.371		
9	0.206	8.075	0.191	7.487
9A	0.043	1.686		
10	0.128	5.018		
10A	0.088	3.450		
11	0.067	2.626		
11A	0.036	1.411		
12	0.119	4.665	0.116	4.547
12A	0.037	1.450		
13	0.252	9.878		
13A	0.091	3.567		
14	0.095	3.724		
14A	0.053	2.078		
15	0.107	4.116		
15A	0.096	3.763		
16	0.117	4.586	0.098	3.842
16A	0.070	2.744		
17	0.093	3.646	0.088	3.450
17A	0.088	3.450		
18	0.064	2.509		
18A	0.024	0.941		
19	0.092	3.606		
19A	0.008	0.314		
20	0.099	3.881		
20A	0.006	0.235		
21	0.109	4.273	0.099	3.881
21A	0.086	3.371		
22	0.057	2.234		
22A	0.010	0.392		
23	0.007	0.274		
23A	0.005	0.196		
24	0.011	0.431		
24A	0.003	0.118		
25	0.053	2.078		
25A	0.004	0.157		
26	0.140	5.488	0.130	5.096
26A	0.053	1.999		
27	0.079	3.097		
27A	0.006	0.235		
28	0.034	1.333		
28A	0.005	0.196		
29	0.041	1.607		
29A	0.004	0.157		
30	0.035	1.372		
30A	0.001	0.039		
31	0.044	1.725		
31A	0.023	0.902		
32	0.053	2.078		
32A	0.020	0.784		
33	0.008	0.314		
33A	0.009	0.353		
34	0.055	2.156	0.048	1.882
34A	0.007	0.274		

THE INFORMATION, INCLUDING ESTIMATED QUANTITIES OF WORK SHOWN ON THESE SHEETS IS BASED ON LIMITED INVESTIGATIONS BY THE STATE AND IS IN NO WAY WARRANTED TO INDICATE THE TRUE CONDITIONS OR ACTUAL QUANTITIES OR DISTRIBUTION OF QUANTITIES OF WORK WHICH WILL BE REQUIRED.

STATE OF CONNECTICUT			
DEPARTMENT OF TRANSPORTATION			
SOUTHINGTON - HARTFORD			
INTERSTATE ROUTE 84			
59 STRUCTURES			
DECK REPAIRS			
CHLORIDE TABLES BR. NOS. 3313 & 3320			
ENGINEER BRIDGE DESIGN UNIT			
DESIGNER	G. D. B.	DRAFTER	T. S. R.
CHECKER	G. D. B.	DATE	3/17/82
NO.	DATE	DESCRIPTION	APPROVED <i>[Signature]</i>
REVISIONS		STRUCTURE NO. 131-145-3313-3320	BRIDGE LOG NO. 3313-3320
			STRUCTURE SHEET NO. 25 of 87

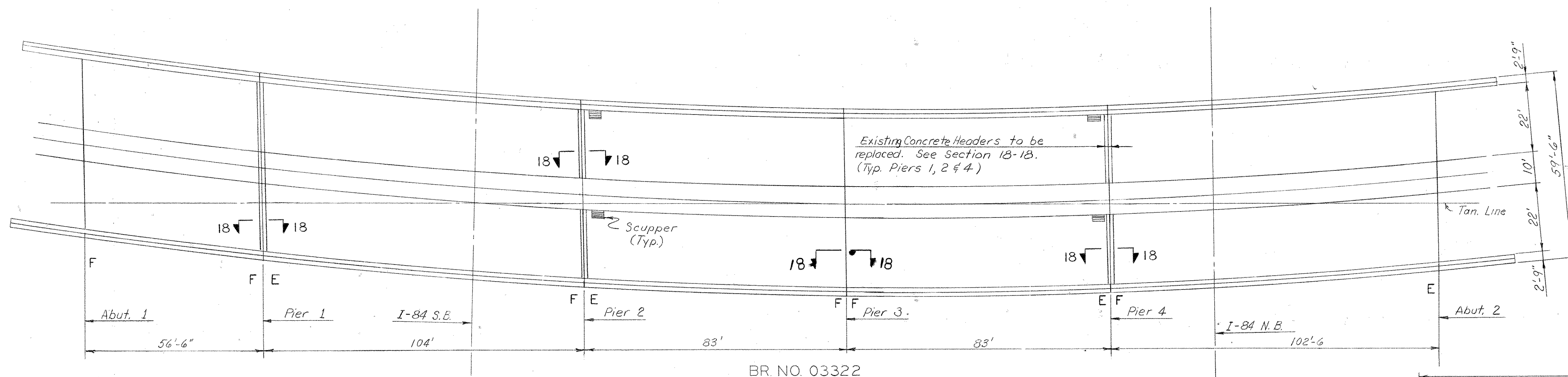

BR NO 03322
PLAN
Scale 1" = 20'

Note: Existing Bituminous Concrete Wearing Surface is in good condition. The only work required is the replacement of the concrete headers at Piers 1, 2, and 4. *ADD PIER 3

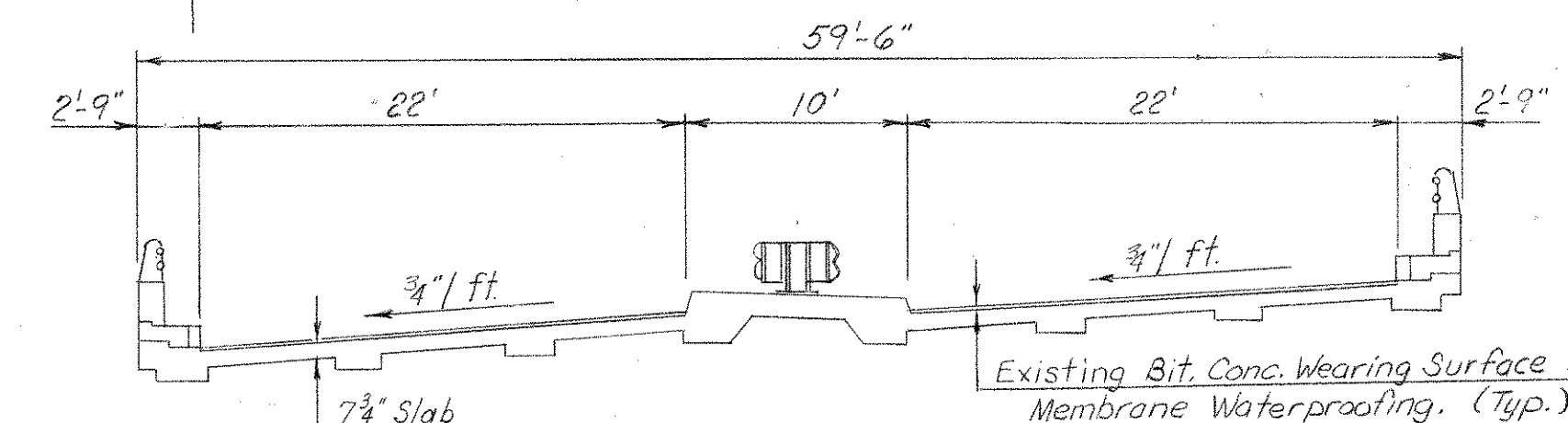

BR NO 03322
TYPICAL BRIDGE SECTION
Scale 6" = 1'-0"

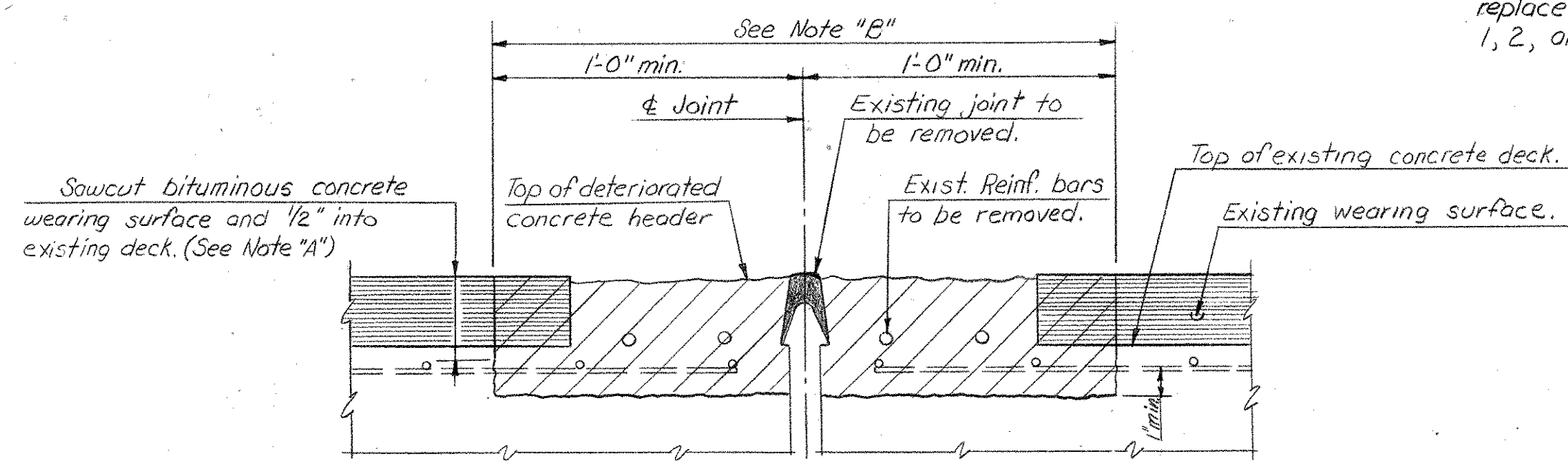

EXISTING CONDITION

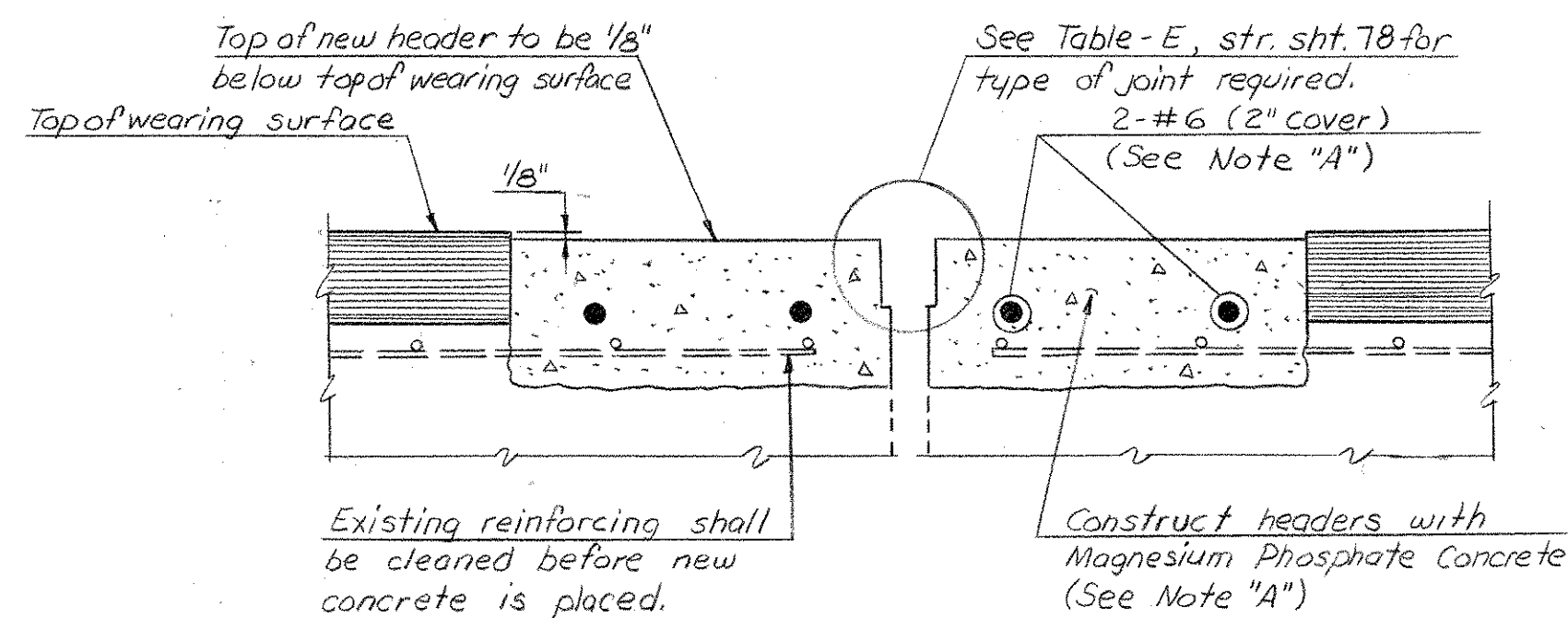

FINAL CONDITION
SECTION 18-18

Note A: See Special Provision for "Construct Concrete Headers."
Note B: Horizontal Limit of work to be done under item "Construct Concrete Headers."

THE INFORMATION, INCLUDING ESTIMATED QUANTITIES OF WORK SHOWN ON THESE SHEETS IS BASED ON LIMITED INVESTIGATIONS BY THE STATE AND IS IN NO WAY WARRANTED TO INDICATE THE TRUE CONDITIONS OR ACTUAL QUANTITIES OR DISTRIBUTION OF QUANTITIES OF WORK WHICH WILL BE REQUIRED.

CONNECTICUT DEPARTMENT OF TRANSPORTATION			
SOUTHINGTON - HARTFORD			
INTERSTATE ROUTE 84 59 STRUCTURES DECK REPAIRS			
SLATER RD. RAMPS OVER I-84			
ENGINEER BRIDGE DESIGN UNIT			
DESIGNER JPL	DRAFTER TSR	CHECKER G.D.B.	
NO. DATE	DESCRIPTION	APPROVED <i>[Signature]</i>	DATE 3/17/82
REVISIONS		STRUCTURE NO. 131-145-3322	BRIDGE LOG NO. 3322 STRUCTURE SHEET NO. 26 of 87

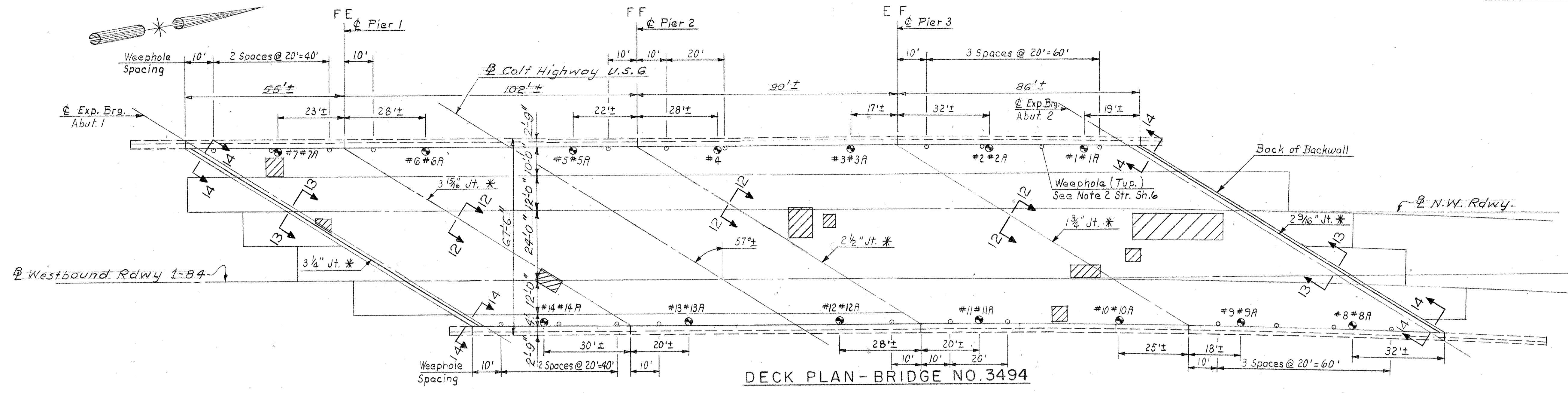

I-84 OVER COLT HIGHWAY (U.S. 6.) DECK.
Scale: 1" = 20'-0"

● Denotes Core Location
* Joint dimensions taken and deck Survey done 7/14/81 (Temp 86°)

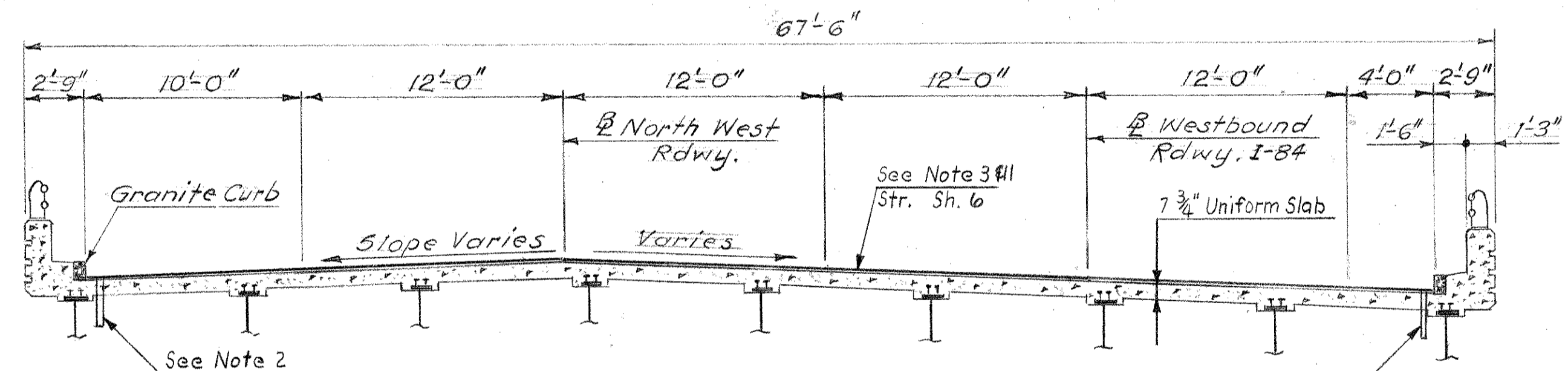

BRIDGE NO. 3494
TYPICAL BRIDGE SECTION
Scale: 3/16" = 1'-0"

CORE NO	BRIDGE NO. 3494			
	CHLORIDE		CONTENT	
	TOTAL	WATER SOLUBLE		
	% BY WT	LBS/CY	% BY WT	LBS/CY
See Note 4, Str. Sh. 6 Date of tests 8/3/81				
1	0.025	0.980		
1A	0.005	0.196		
2	0.006	0.235		
2A	0.001	0.039		
3	0.049	1.921		
3A	0.022	0.862		
4	0.034	1.333		
5	0.003	0.118		
6	0.002	0.078		
6A	0.003	0.118		
7	0.021	0.823		
7A	0.001	0.039		
8	0.046	1.803	0.043	1.686
8A	0.046	1.803		
9	.021	0.823		
9A	.005	0.196		
10	.293	11.486	.264	10.349
10A	.164	6.429	.146	5.723
11	.026	1.019		
11A	.006	0.235		
12	.014	0.549		
12A	.006	0.235		
13	.004	0.157		
13A	.004	0.157		
14	.086	3.371	.082	3.214
14A	.046	1.803		

Note: For Section 12-12 see Str. Sh. 82
For Sections 13-13, 14-14 see Str. Sh. 83

CONNECTICUT		
DEPARTMENT OF TRANSPORTATION		
SOUTHINGTON - HARTFORD		
INTERSTATE ROUTE 84		
59 STRUCTURES		
DECK REPAIRS		
I-84 W.B. OVER ROUTE 6		
ENGINEER BRIDGE DESIGN UNIT		
DESIGNER J. P. L.	DRAFTSMAN G. O. K.	CHECKER G. D. B.
NO. DATE	DESCRIPTION	DATE
	APPROVED <i>W. A. Johnson</i>	DATE 3/17/82
REVISIONS		STRUCTURE NO. 131-145-3494
		BRIDGE LOG NO. 3494
		STRUCTURE SHEET NO. 27 of 87

THE INFORMATION, INCLUDING ESTIMATED QUANTITIES OF WORK SHOWN ON THESE SHEETS IS BASED ON LIMITED INVESTIGATIONS BY THE STATE AND IS IN NO WAY WARRANTED TO INDICATE THE TRUE CONDITIONS OR ACTUAL QUANTITIES OR DISTRIBUTION OF QUANTITIES OF WORK WHICH WILL BE REQUIRED.

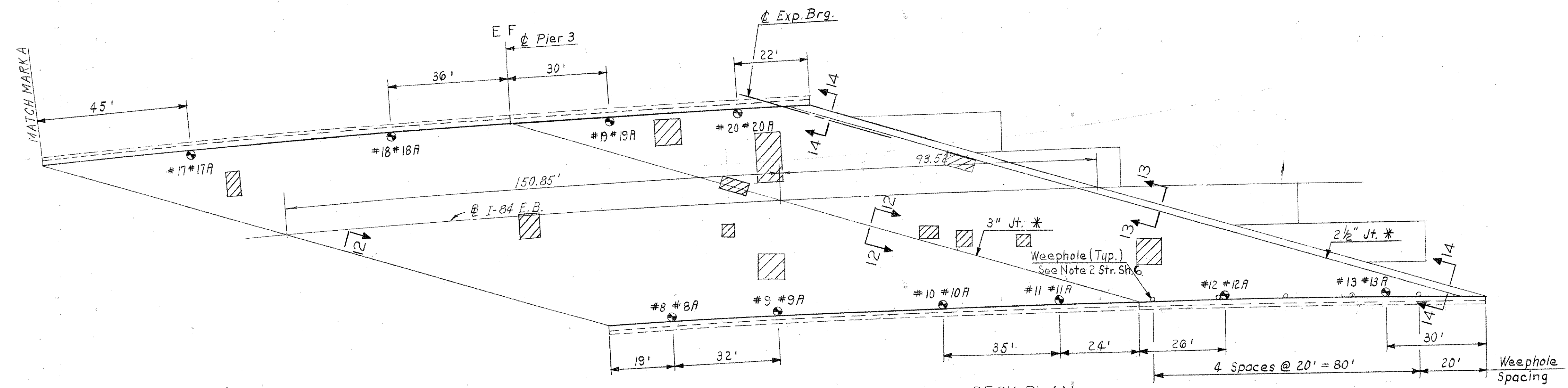
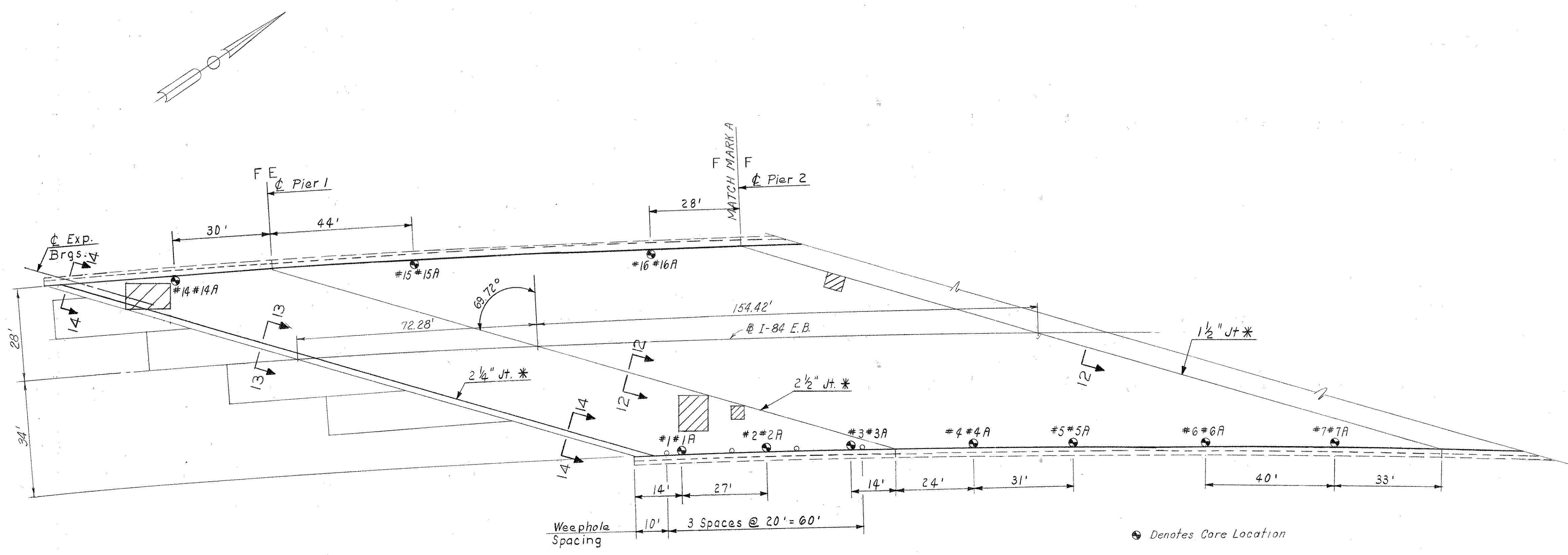

BRIDGE NO. 3495

CORE NO.	CHLORIDE CONTENT		WATER SOLUBLE	
	% BY WT.	LBS./CY.	% BY WT.	LBS./CY.
(See Note 4 Str. Sht. 6 Date 7/24/81)				
1	0.053	2.078		
1A	0.015	0.588		
2	0.069	2.705		
2A	0.009	0.353		
3	0.045	1.764		
3A	0.004	0.157		
4	0.008	0.314		
4A	0.005	0.196		
5	0.094	3.685	0.079	3.097
5A	0.042	1.646		
6	0.048	1.882		
6A	0.005	0.196		
7	0.074	2.901		
7A	0.035	1.372		
8	0.064	2.509		
8A	0.016	0.627		
9	0.061	2.391		
9A	0.034	1.333		
10	0.086	3.371	0.082	3.214
10A	0.034	1.333		
11	0.086	3.371		
11A	0.005	0.196		
12	0.104	4.077	0.090	3.528
12A	0.012	0.470		
13	0.014	0.549		
13A	0.002	0.078		
14	0.007	0.274		
14A	0.004	0.157		
15	0.058	2.274		
15A	0.009	0.353		
16	0.037	1.450		
16A	0.002	0.078		
17	0.013	0.510		
17A	0.006	0.235		
18	0.011	0.431		
18A	0.002	0.078		
19	0.081	3.175	0.074	2.901
19A	0.006	0.235		
20	0.047	1.842		
20A	0.010	0.392		

Note: For Section 12-12 see Str. Sht. 82
For Sections 13-13 & 14-14 see Str. Sht. 83

DECK PLAN
BRIDGE NO. 3495
Scale 1" = 20'

* Joint dimensions taken and deck survey done 7/24/81.

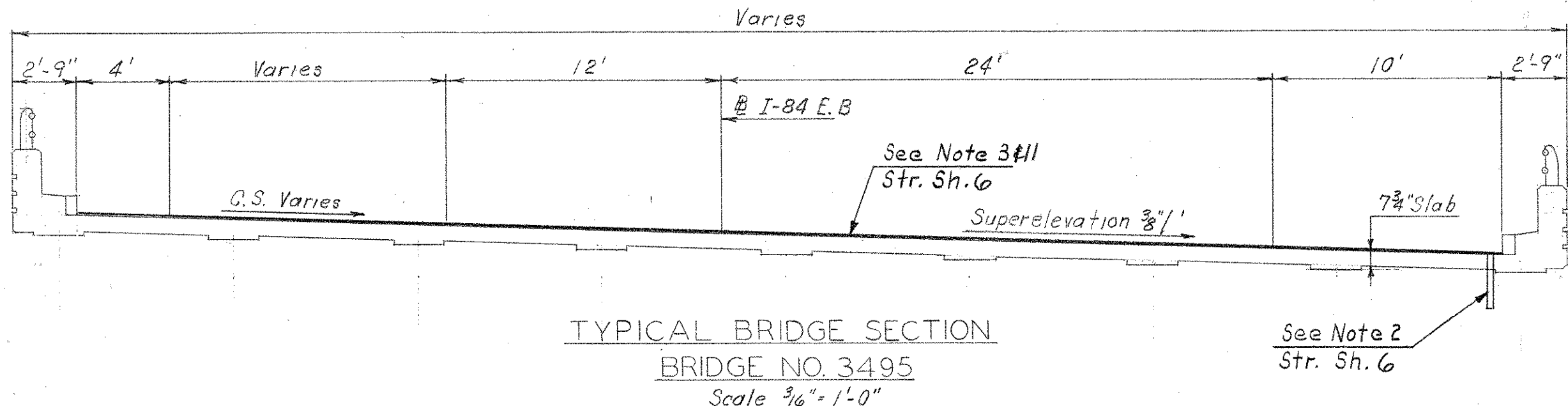

TYPICAL BRIDGE SECTION
BRIDGE NO. 3495
Scale 3/8" = 1'-0"

See Note 2
Str. Sh. 6

THE INFORMATION, INCLUDING ESTIMATED QUANTITIES OF WORK SHOWN ON THESE SHEETS IS BASED ON LIMITED INVESTIGATIONS BY THE STATE AND IS IN NO WAY WARRANTED TO INDICATE THE TRUE CONDITIONS OR ACTUAL QUANTITIES OR DISTRIBUTION OF QUANTITIES OF WORK WHICH WILL BE REQUIRED.

CONNECTICUT		
DEPARTMENT OF TRANSPORTATION		
SOUTHINGTON - HARTFORD		
INTERSTATE ROUTE 84		
59 STRUCTURES		
DECK REPAIRS		
I-84 E.B. OVER EASTBOUND ROUTE 6		
ENGINEER BRIDGE DESIGN UNIT		
DESIGNER	J.P.L.	CHECKER G.D.B.
DRAFTER	T.S.R.	
APPROVED	<i>[Signature]</i>	DATE 3/17/82
NO.	DATE	DESCRIPTION
REVISIONS		
STRUCTURE NO. 131-145-03495		BRIDGE LOG NO. 03495
		STRUCTURE SHEET NO. 28 of 87

BRIDGE NO. 3499

CORE NO.	CHLORIDE CONTENT		%	WATER SOLUBLE	%
	BY WT.	BY WT.			
	%	LBS./CY		LBS./CY	
(See Note 4 Str. Sht. 6 Date 8/13/81)					
1	0.207	8.114			
1A	0.115	4.508			
2	0.256	10.035	0.224	8.781	
2A	0.126	4.939			
3	0.232	9.094	0.218	8.546	
3A	0.065	2.548			
4	0.211	8.271			
4A	0.100	3.920			
5	0.258	10.114	0.250	9.800	
5A	0.091	3.567			
6	0.191	7.487			
6A	0.107	4.194			
7	0.244	9.564	0.227	8.898	
7A	0.066	2.587			
8	0.219	8.584			
9	0.126	4.939			
9A	0.094	3.684			
10	0.223	8.742	0.213	8.350	
10A	0.123	4.882			
11	0.157	6.154			
11A	0.094	3.684			

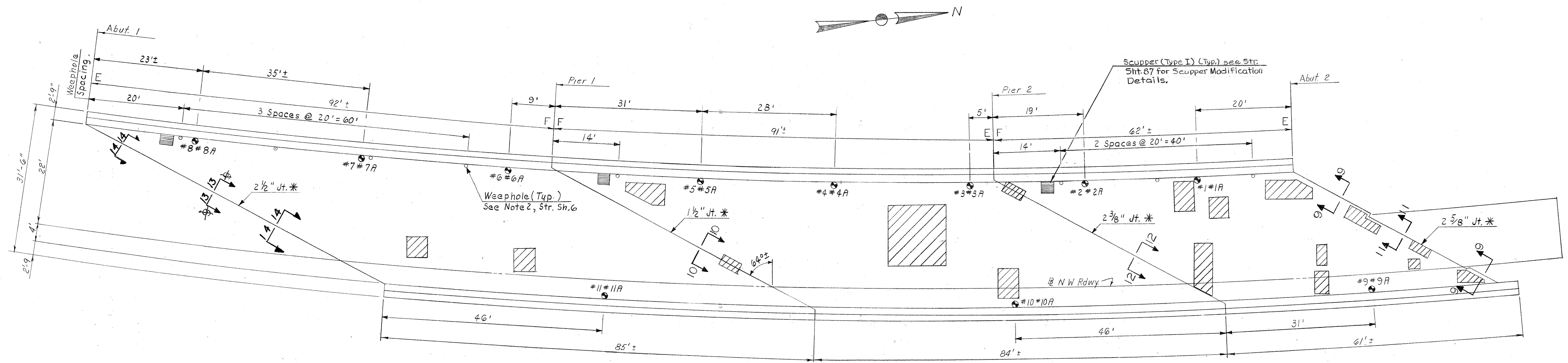

BR. NO. 03499
PLAN
Scale 1"=10'-0"

⊙ Denotes Core Location
* Jt. dimensions taken 8/6/81 (Temp 90°)

Note: For Sections 9-9 & 10-10 see Str. Sht. 86
For Sections 11-11 & 12-12 see Str. Sht. 82

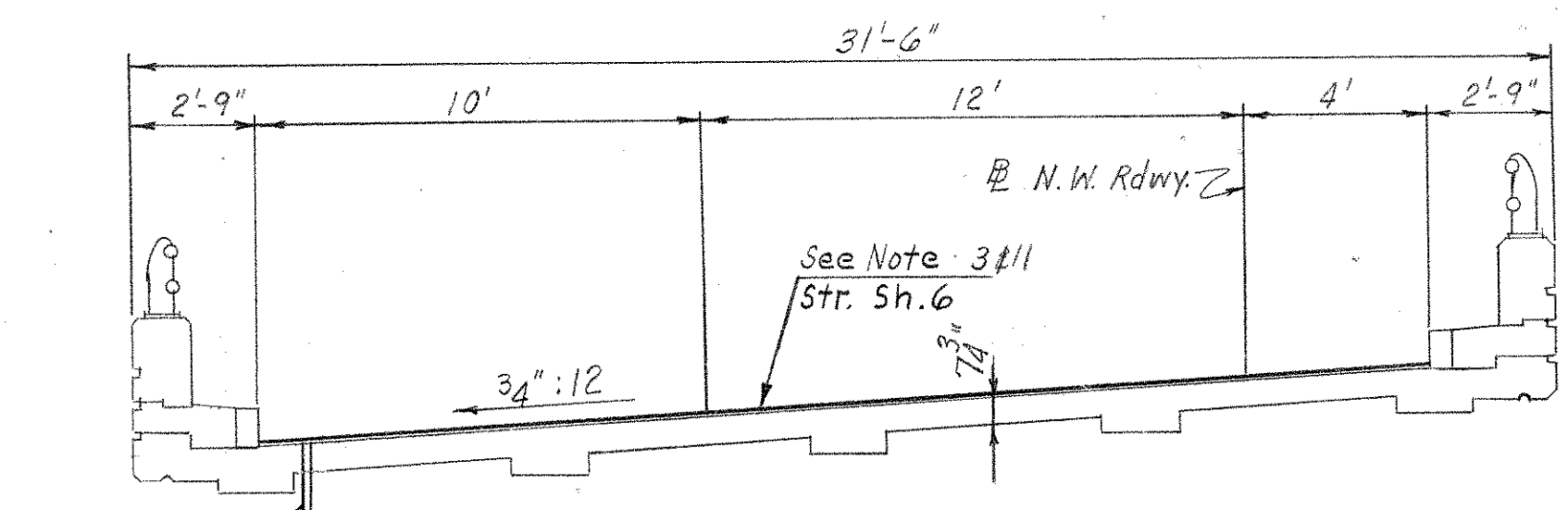

BR. NO. 03499
TYPICAL BRIDGE CROSS SECTION
Scale 4"=1'-0"

See Note 2
Str. Sh. 6

THE INFORMATION, INCLUDING ESTIMATED QUANTITIES OF WORK SHOWN ON THESE SHEETS IS BASED ON LIMITED INVESTIGATIONS BY THE STATE AND IS IN NO WAY WARRANTED TO INDICATE THE TRUE CONDITIONS OR ACTUAL QUANTITIES OR DISTRIBUTION OF QUANTITIES OF WORK WHICH WILL BE REQUIRED.

CONNECTICUT			
DEPARTMENT OF TRANSPORTATION			
SOUTHINGTON - HARTFORD			
INTERSTATE ROUTE 84			
59 STRUCTURES			
DECK REPAIRS			
RT. 4 RAMP OVER RAMPS			
ENGINEER BRIDGE DESIGN UNIT			
DESIGNER	J.P.L.	DRAFTER	T.S.R.
CHECKER	G.D.B.		
NO.	DATE	DESCRIPTION	APPROVED
			<i>[Signature]</i>
REVISIONS		STRUCTURE NO. 131-145-3499	DATE 3/17/82
		BRIDGE LOG NO. 3499	STRUCTURE SHEET NO. 29 OF 87

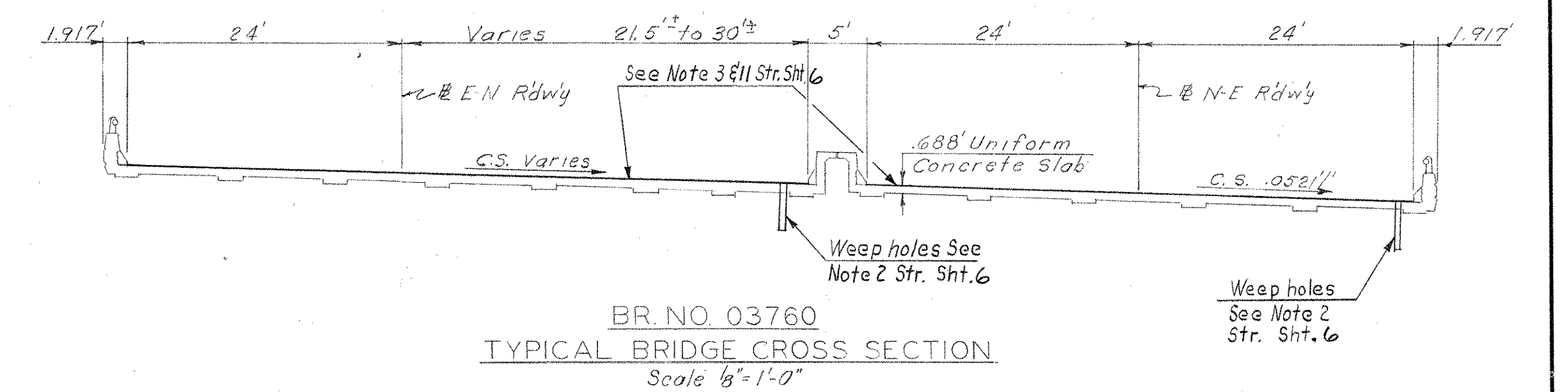
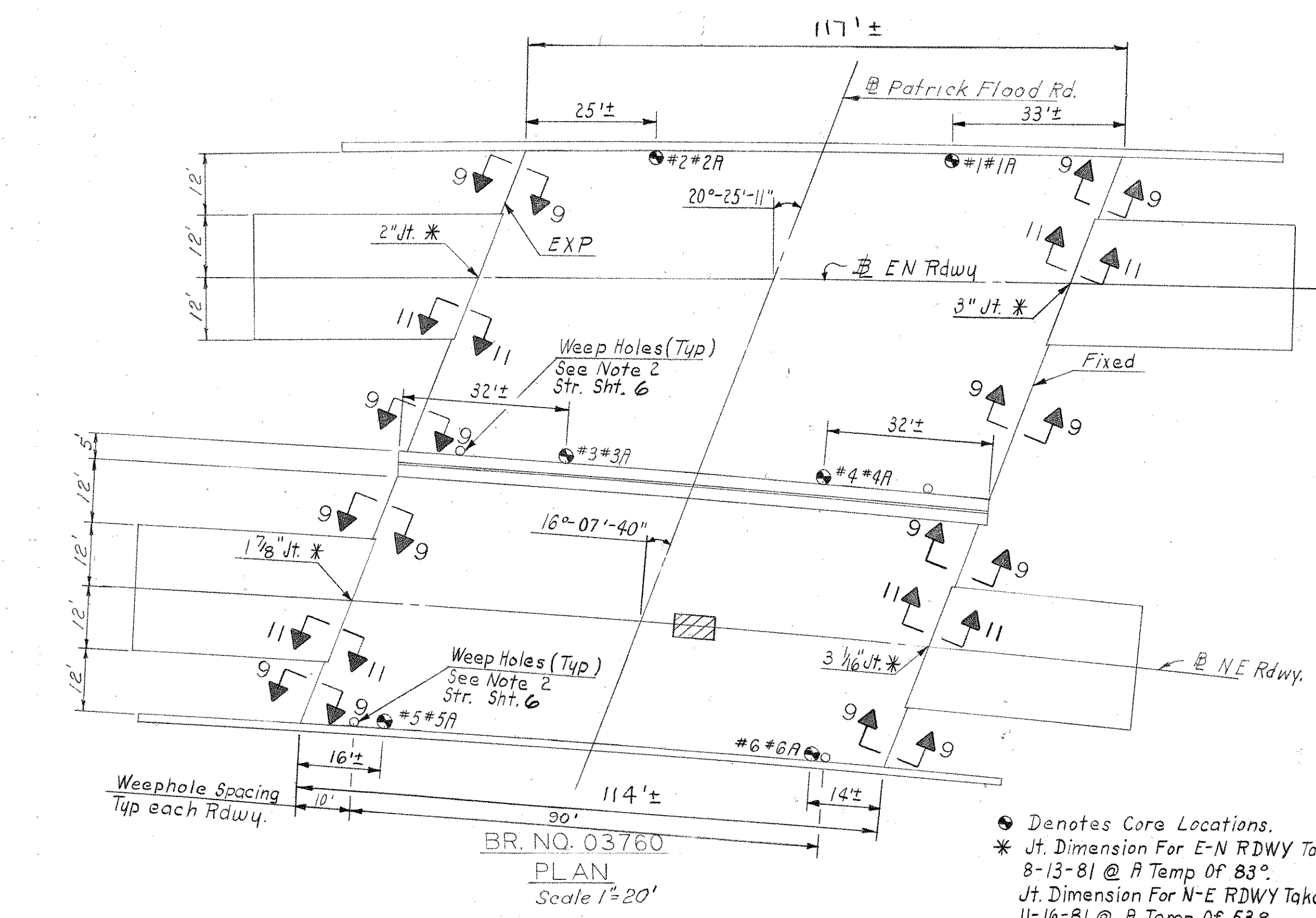
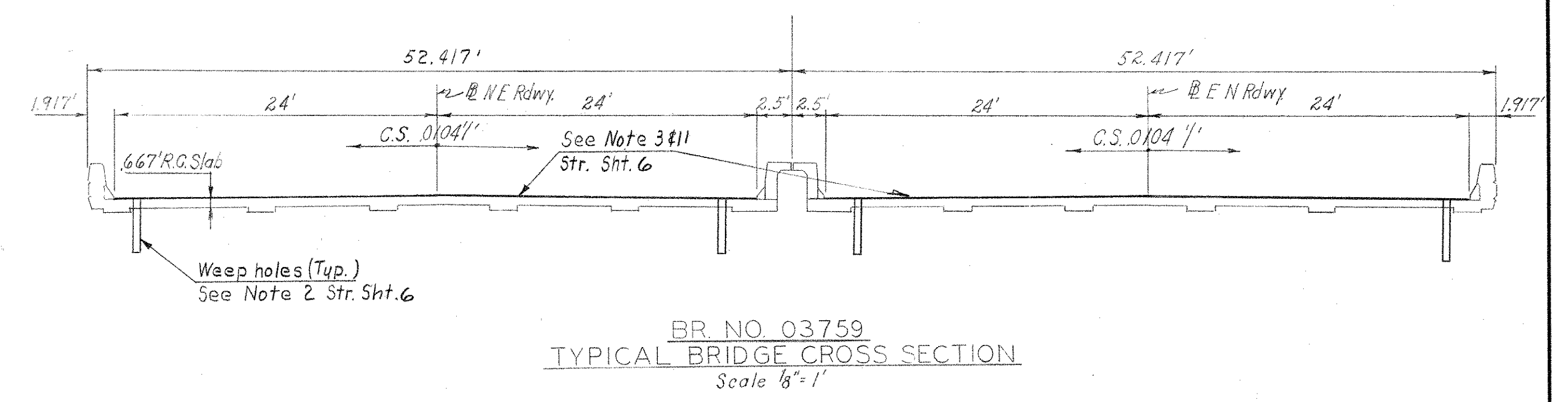
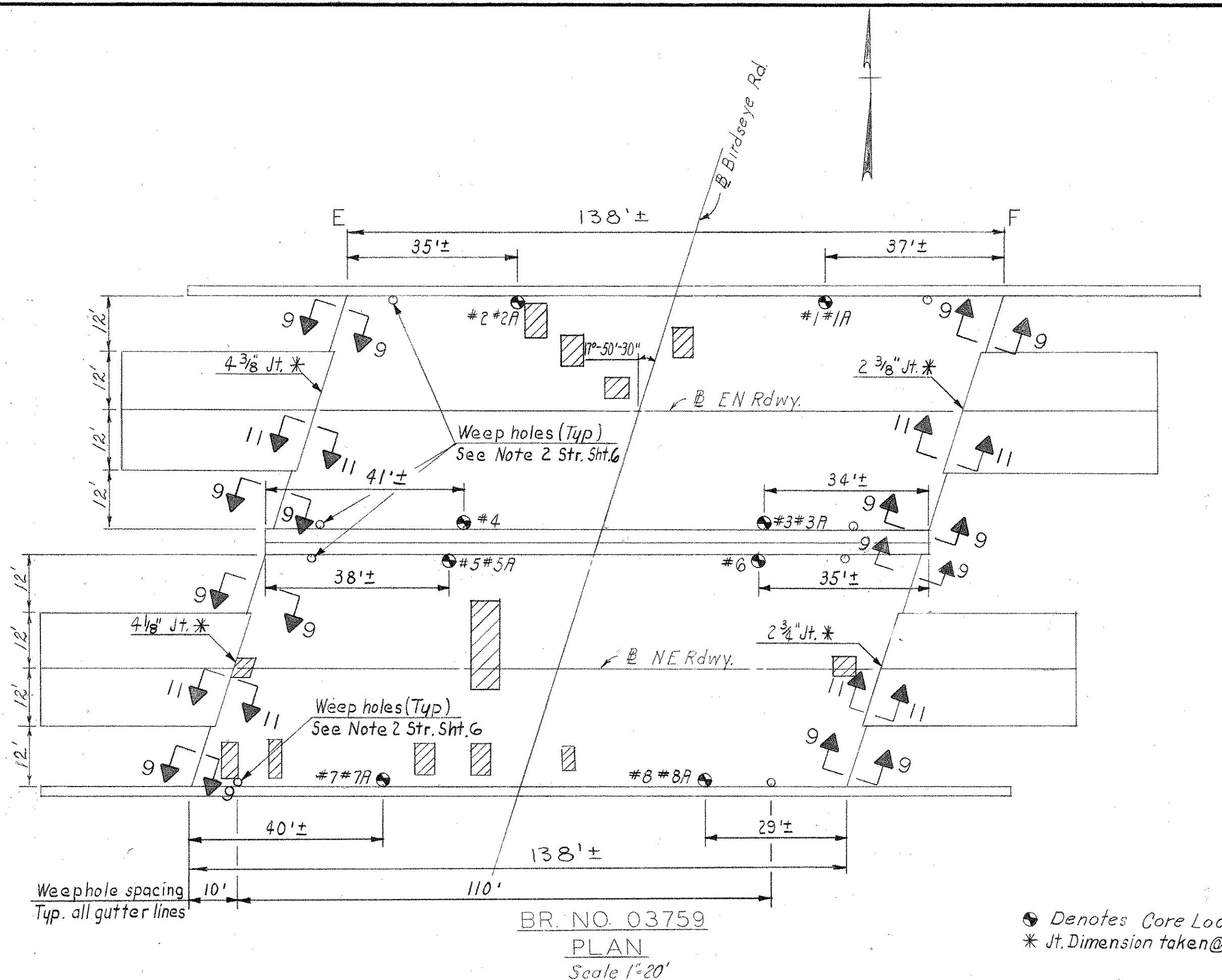

BR. NO. 3759

CORE NO.	CHLORIDE CONTENT		WATER SOLUBLE	
	TOTAL			
	% BY WT.	LBS./CY.	% BY WT.	LBS./CY.
(See Note 4 Str. Sht. 6) Date 12/30/81				
1	0.070	2.744		
1A	0.009	0.353		
2	0.077	3.018	0.066	2.587
2A	0.010	0.392		
3	0.073	2.862		
3A	0.011	0.431		
4	0.023	0.902		
5	0.074	2.901		
5A	0.009	0.353		
6	0.034	1.333		
7	0.085	3.322		
7A	0.009	0.353		
8	0.145	5.684	0.136	5.331
8A	0.018	0.706		

BR. NO. 3760

CORE NO.	CHLORIDE CONTENT		WATER SOLUBLE	
	TOTAL			
	% BY WT.	LBS./CY.	% BY WT.	LBS./CY.
(See Note 4 Str. Sht. 6) Dates 8/18/81 & 12/28/81				
1	0.009	0.353		
1A	0.006	0.235		
2	0.025	0.980		
2A	0.007	0.274		
3	0.011	0.431		
3A	0.007	0.374		
4	0.010	0.392		
4A	0.007	0.274		
5	0.076	2.979		
5A	0.006	0.235		
6	0.091	3.567	0.086	3.371
6A	0.005	0.196		
7	0.012	0.470		

Note: For Section 9-9 see Str. Sht. 86
For Section 11-11 see Str. Sht. 82

CONNECTICUT
DEPARTMENT OF TRANSPORTATION
SOUTHINGTON - HARTFORD
INTERSTATE ROUTE 84
59 STRUCTURES
DECK REPAIRS
RT. 4 OVER LOCAL ROADS

ENGINEER BRIDGE DESIGN UNIT		
DESIGNER J.P.L.	DRAFTER T.S.R.	CHECKER G.D.B.
APPROVED <i>[Signature]</i>	DATE 3/17/82	
NO. DATE	DESCRIPTION	
REVISIONS		
STRUCTURE NO. 131-145-3759 & 3760		BRIDGE LOG NO. 3759 & 3760
		STRUCTURE SHEET NO. 30 of 87

THE INFORMATION, INCLUDING ESTIMATED QUANTITIES OF WORK SHOWN ON THESE SHEETS IS BASED ON LIMITED INVESTIGATIONS BY THE STATE AND IS IN NO WAY WARRANTED TO INDICATE THE TRUE CONDITIONS OR ACTUAL QUANTITIES OR DISTRIBUTION OF QUANTITIES OF WORK WHICH WILL BE REQUIRED.

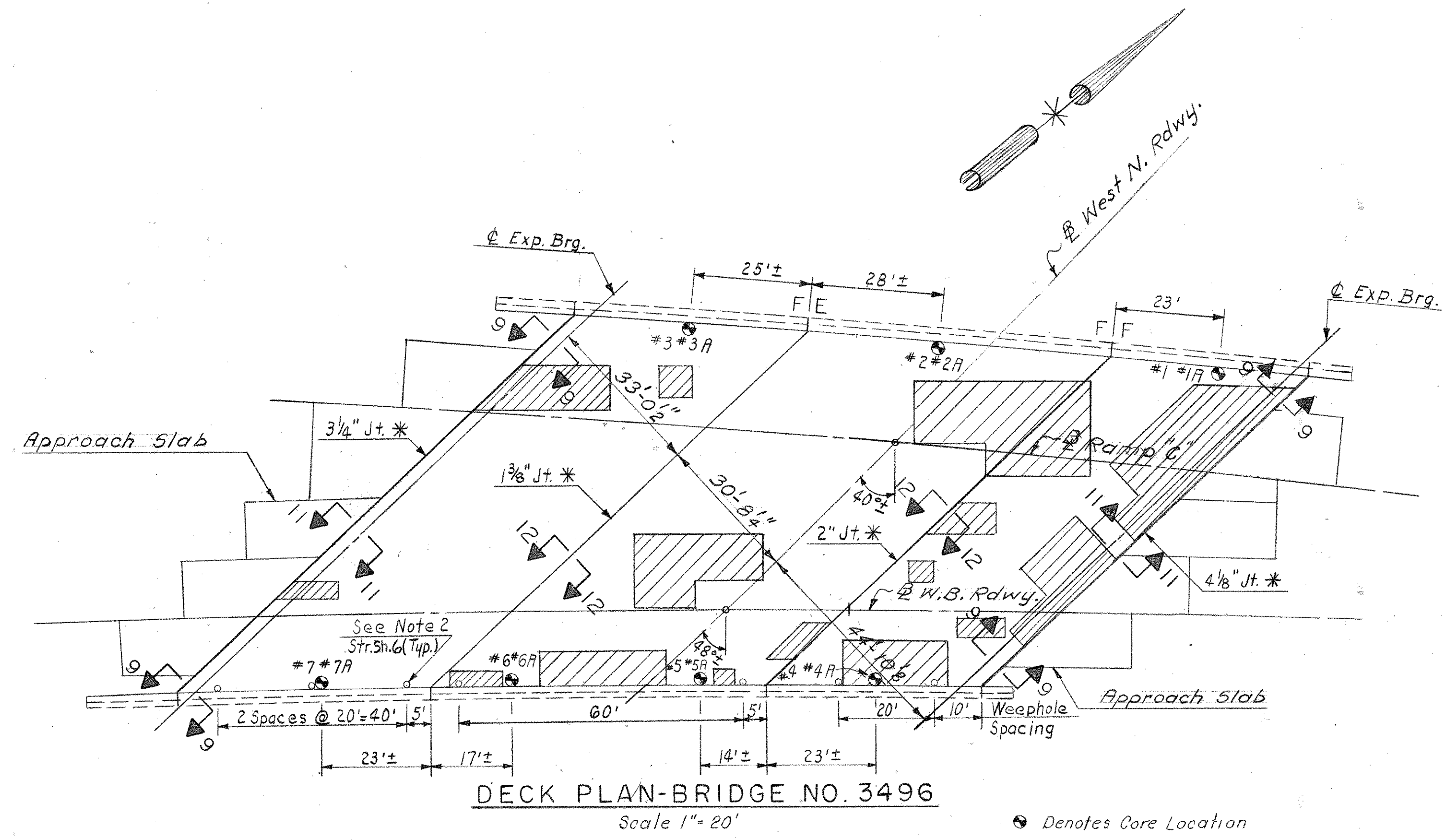

DECK PLAN-BRIDGE NO. 3496
Scale 1" = 20'

• Denotes Core Location
* Jt. dimensions taken 7/21/81 (Temp 81°)
Deck Condition Survey Done 7-21-81

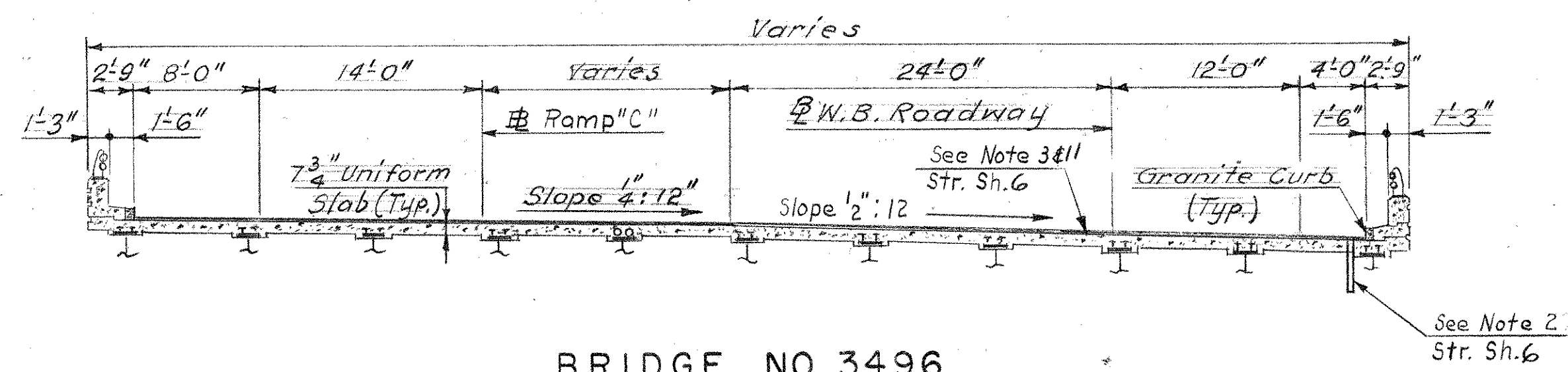

BRIDGE NO. 3496
TYPICAL BRIDGE SECTION
(Looking East)
Scale 1/8" = 1'-0"

Note: For Section 9-9, see Str. Sht. 86
For Sections 11-11 & 12-12, see Str. Sht. 82

CORE NO.	CHLORIDE CONTENT	
	TOTAL	WATER SOLUBLE
	% BY WT. LBS./CY.	% BY WT. LBS./CY.
(See Note 4 Str. Sh. 6 Date 8/17/81)		
1	0.142	5.566
1A	0.034	1.333
2	0.046	1.803
2A	0.006	0.235
3	0.060	2.352
3A	0.015	0.588
4	0.150	5.880
4A	0.007	0.274
5	0.006	0.235
5A	0.004	0.157
6	0.116	4.547
6A	0.007	0.274
7	0.009	0.353
7A	0.003	0.118

THE INFORMATION, INCLUDING ESTIMATED QUANTITIES OF WORK SHOWN ON THESE SHEETS IS BASED ON LIMITED INVESTIGATIONS BY THE STATE AND IS IN NO WAY WARRANTED TO INDICATE THE TRUE CONDITIONS OR ACTUAL QUANTITIES OR DISTRIBUTION OF QUANTITIES OF WORK WHICH WILL BE REQUIRED.

CONNECTICUT DEPARTMENT OF TRANSPORTATION		
SOUTHINGTON - HARTFORD		
INTERSTATE ROUTE 84 59 STRUCTURES		
DECK REPAIRS		
W.B. I-84 OVER RAMP TO ROUTE 4		
ENGINEER BRIDGE DESIGN UNIT		
DESIGNER J. P. L.	DRAFTSMAN G. O. K.	CHECKER G. D. B.
APPROVED <i>[Signature]</i>	DATE 3/17/82	
NO. DATE	DESCRIPTION	REVISIONS
STRUCTURE NO. 131-145-3496		BRIDGE LOG NO. 3496
		STRUCTURE SHEET NO. 31 of 87

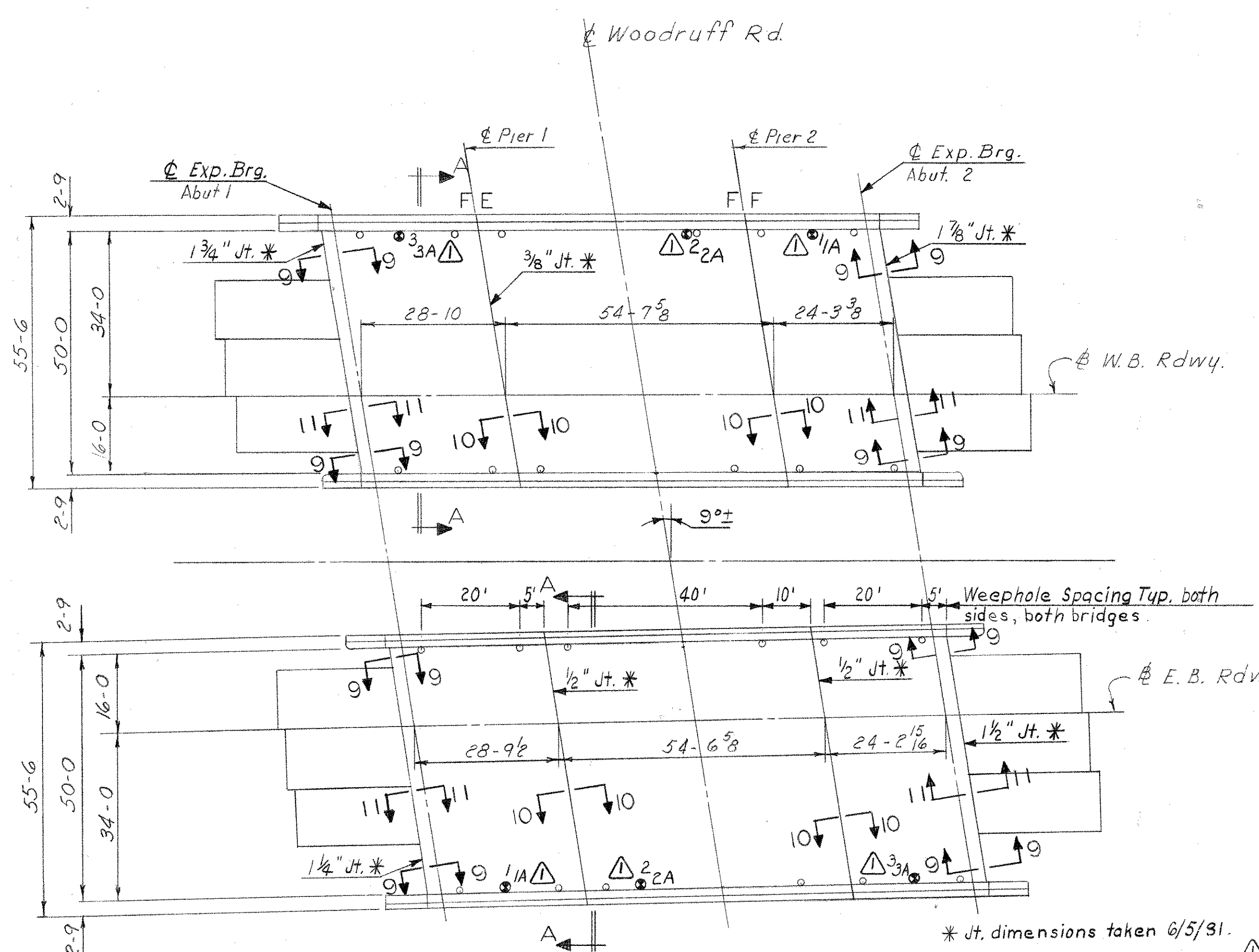

BR. NO. 03485 E.B.
BR. NO. 03486 W.B.
PLAN
Scale 1" = 20'

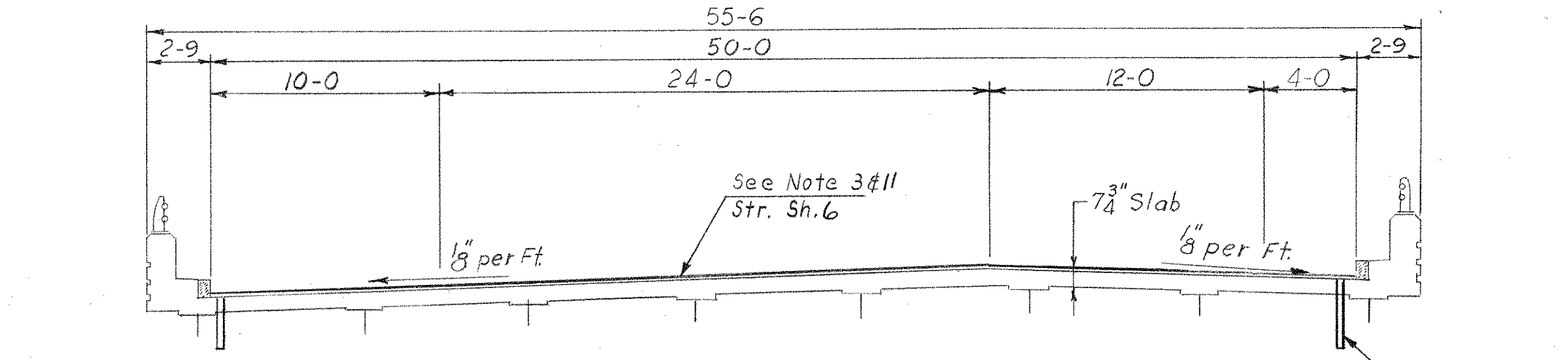
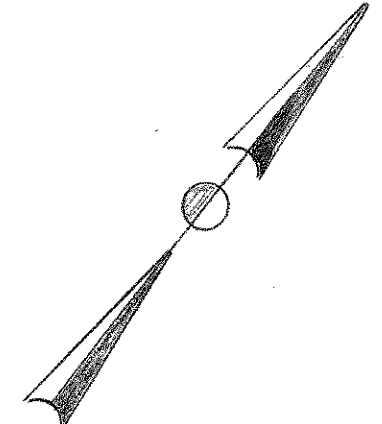

BR. NOS. 03485 & 03486
SECTION A-A
Scale 3/8" = 1'-0"

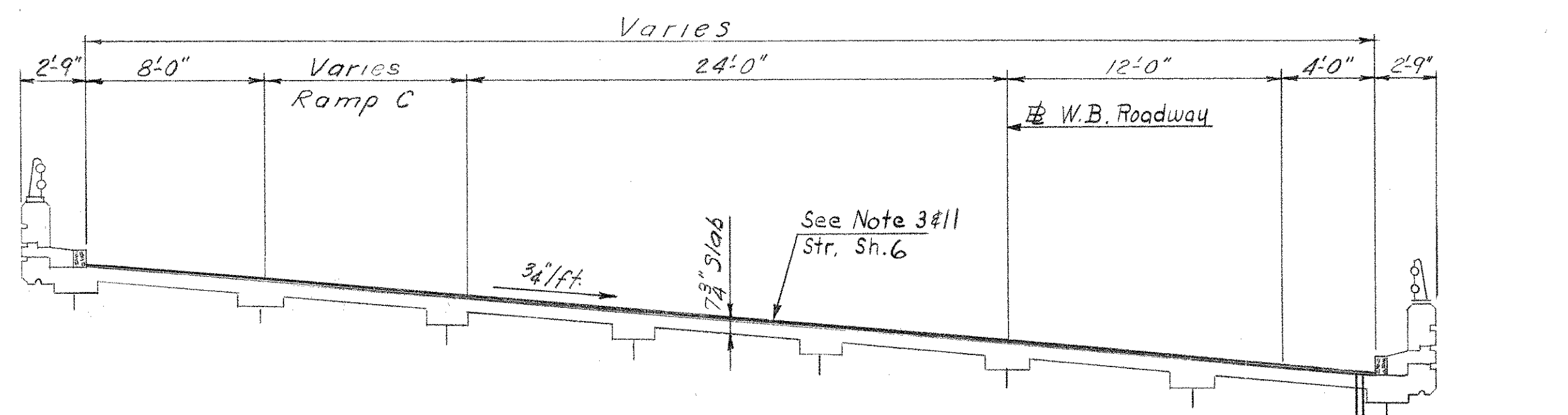

BR. NO. 03497
TYPICAL BRIDGE SECTION (Looking East)
Scale 3/8" = 1'-0"

CORE NO.	BR. NO. 03485			
	CHLORIDE TOTAL		CONTENT WATER SOLUBLE	
	% BY WT./LBS./C.Y.	% BY WT./LBS./C.Y.	% BY WT./LBS./C.Y.	% BY WT./LBS./C.Y.
1	0.012	0.470		
1A	0.004	0.157		
2	0.021	0.823	0.016	0.627
2A	0.004	0.157		
3	0.016	0.627		
3A	0.003	0.118		

CORE NO.	BR. NO. 03486			
	CHLORIDE TOTAL		CONTENT WATER SOLUBLE	
	% BY WT./LBS./C.Y.	% BY WT./LBS./C.Y.	% BY WT./LBS./C.Y.	% BY WT./LBS./C.Y.
1	0.003	0.118		
1A	0.004	0.157		
2	0.004	0.157		
2A	0.004	0.157		
3	0.029	1.137	0.022	0.862
3A	0.022	0.862		

CORE NO.	BR. NO. 03497			
	CHLORIDE TOTAL		CONTENT WATER SOLUBLE	
	% BY WT./LBS./C.Y.	% BY WT./LBS./C.Y.	% BY WT./LBS./C.Y.	% BY WT./LBS./C.Y.
1	0.020	0.784		
2	0.086	3.371		
2A	0.006	0.235		
3	0.006	0.235		
4	0.006	0.235		
5	0.021	0.823		
6	0.134	5.253	0.110	4.312
6A	0.065	2.543		
7	0.025	0.196		

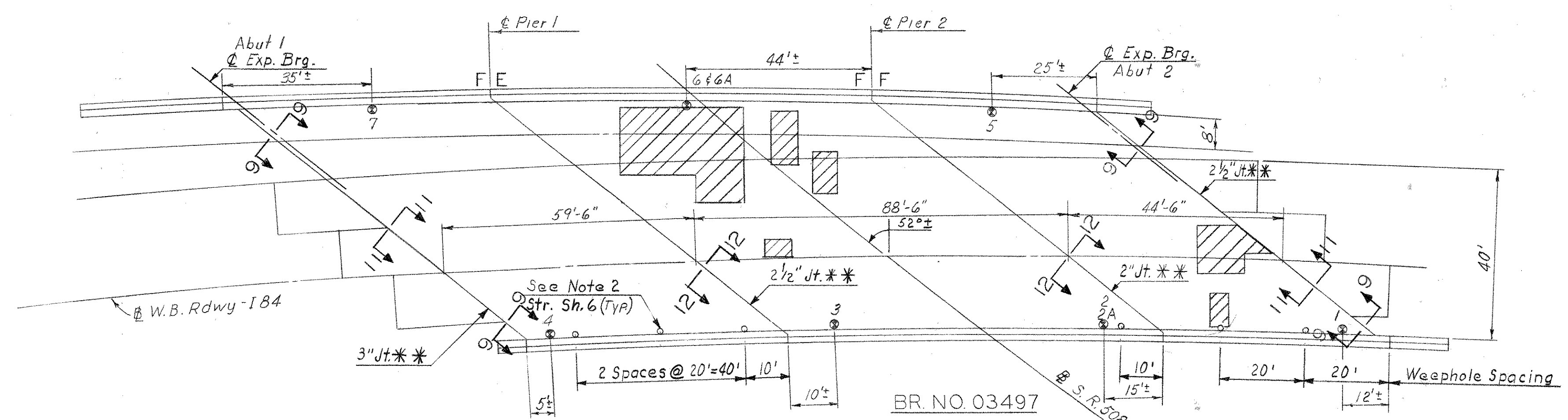

BR. NO. 03497
PLAN
Scale 1" = 20'

** Jt. dimensions taken 11/13/81
(Temp 43°)
⊙ Denotes Core Location
⊙ Deck Condition Survey Done 11-13-81

THE INFORMATION, INCLUDING ESTIMATED QUANTITIES OF WORK SHOWN ON THESE SHEETS IS BASED ON LIMITED INVESTIGATIONS BY THE STATE AND IS IN NO WAY WARRANTED TO INDICATE THE TRUE CONDITIONS OR ACTUAL QUANTITIES OR DISTRIBUTION OF QUANTITIES OF WORK WHICH WILL BE REQUIRED.

Note: For Sections 9-9 & 10-10 see Str. Sht. 86
For Sections 11-11 & 12-12 see Str. Sht. 82

CONNECTICUT DEPARTMENT OF TRANSPORTATION	
SOUTHINGTON - HARTFORD	
INTERSTATE ROUTE 84 59 STRUCTURES	
DECK REPAIRS	
I-84 E.B. & W.B. OVER WOODRUFF RD. AND S.R. 508	
ENGINEER BRIDGE DESIGN UNIT	
DESIGNER J.P.L.	DRAFTSMAN T.S.R.
CHECKER G.D.B.	
APPROVED <i>[Signature]</i>	DATE 3/17/82
NO. DATE DESCRIPTION	BRIDGE LOG NO. STRUCTURE SHEET NO.
REVISIONS	3485, 3486, 3497 32 of 87

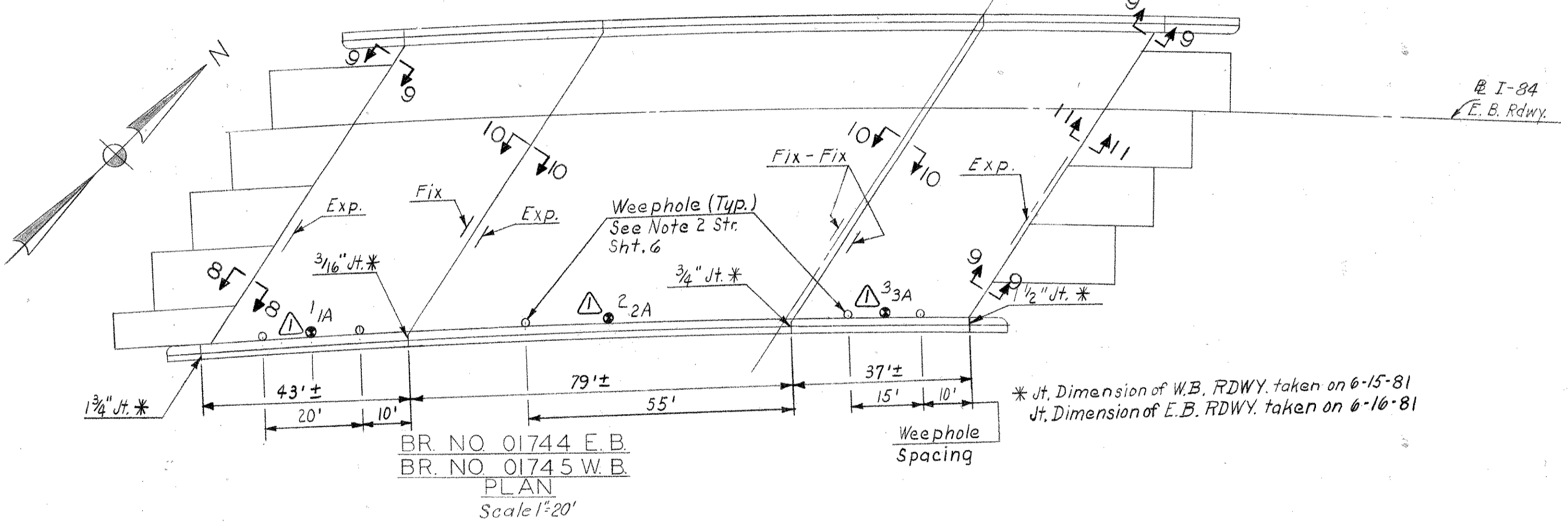
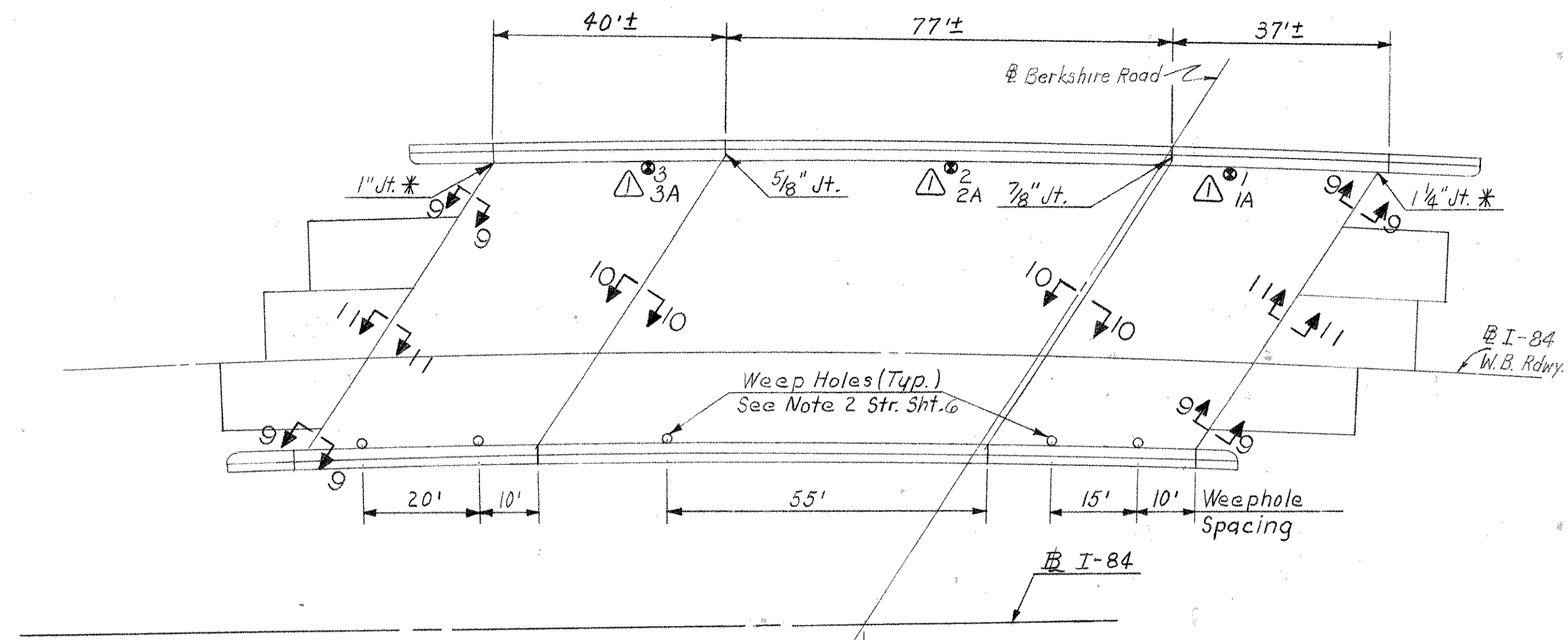

BR. NO. 01744 E.B.
BR. NO. 01745 W.B.
PLAN
Scale 1"=20'

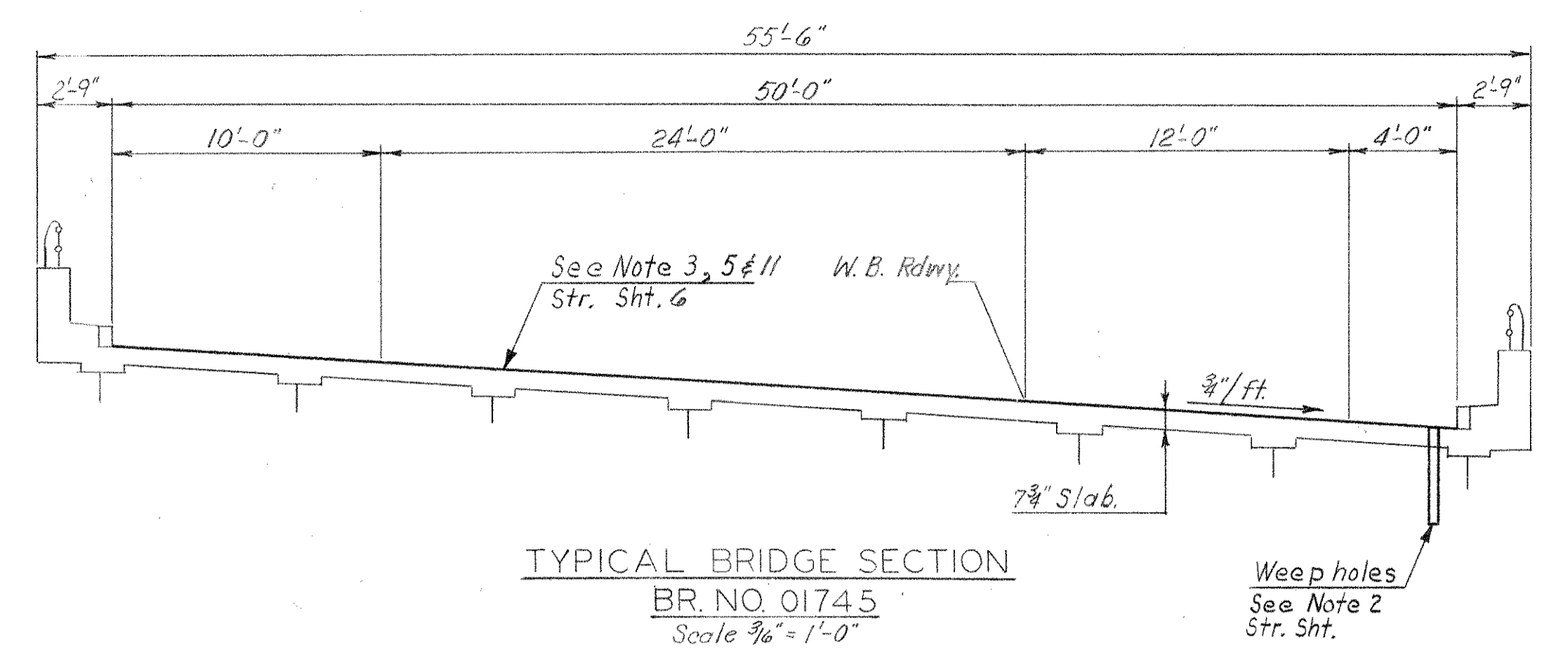

TYPICAL BRIDGE SECTION
BR. NO. 01745
Scale 3/8"=1'-0"

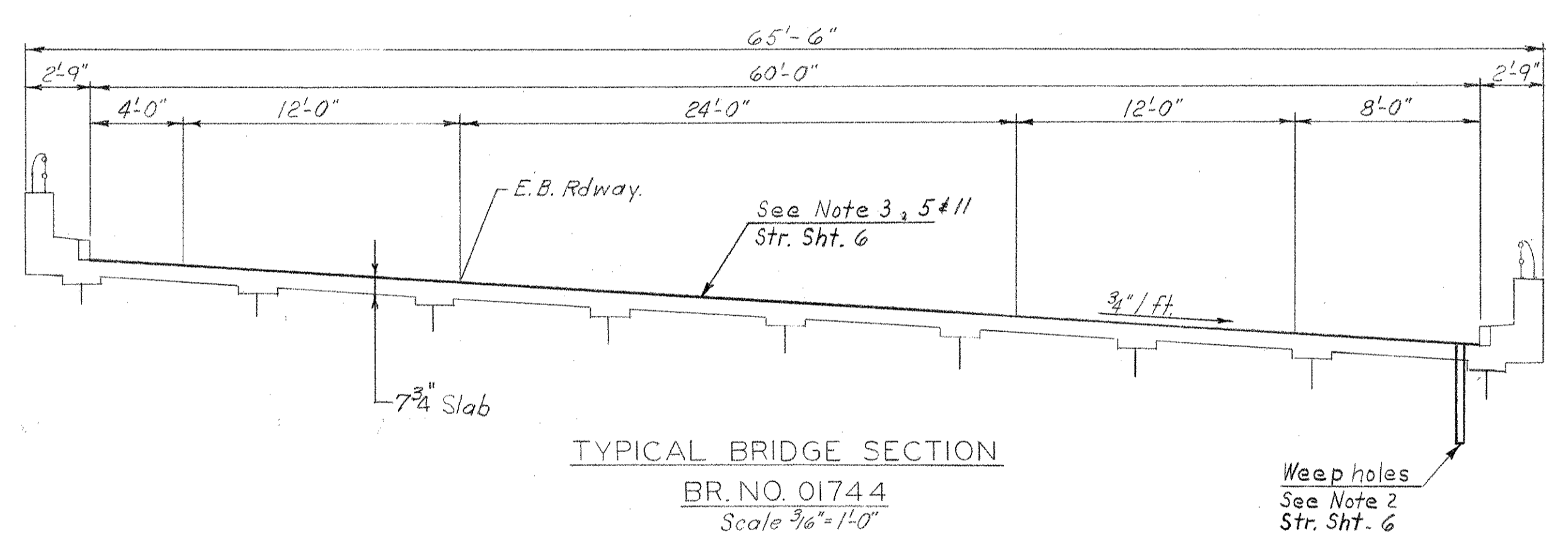

TYPICAL BRIDGE SECTION
BR. NO. 01744
Scale 3/8"=1'-0"

CORE NO.	BR. NO. 01744			
	CHLORIDE TOTAL		CONTENT WATER SOLUBLE	
	% BY WT.	LBS./C.Y.	% BY WT.	LBS./C.Y.
1	0.016	0.627	0.016	0.627
1A	0.001	0.039		
2	0.006	0.235		
2A	0.002	0.078		
3	0.002	0.078		
3A	0.002	0.078		

CORE NO.	BR. NO. 01745			
	CHLORIDE TOTAL		CONTENT WATER SOLUBLE	
	% BY WT.	LBS./C.Y.	% BY WT.	LBS./C.Y.
1	0.035	1.372	0.030	1.176
1A	0.034	1.333		
2	0.003	0.118		
2A	0.004	0.157		
3	0.001	0.039		
3A	0.001	0.039		

△ • Denotes Core Locations

Note: For Sections 9-9 & 10-10 see Str. Sht. 86
For Section 11-11 see Str. Sht. 82.

CONNECTICUT			
DEPARTMENT OF TRANSPORTATION			
SOUTHINGTON - HARTFORD			
INTERSTATE ROUTE 84			
59 STRUCTURES			
DECK REPAIRS			
I-84 E.B. & W.B. OVER BERKSHIRE RD.			
ENGINEER BRIDGE DESIGN UNIT			
DESIGNER J. P. L.		DRAFTER T. S. R.	
CHECKER G. D. B.		DATE 3/17/82	
APPROVED <i>[Signature]</i>		DATE 3/17/82	
STRUCTURE NO. 131-145-1744 & 1745		BRIDGE LOG NO. 1744 & 1745	
REVISIONS		STRUCTURE SHEET NO. 34 of 87	

THE INFORMATION, INCLUDING ESTIMATED QUANTITIES OF WORK SHOWN ON THESE SHEETS IS BASED ON LIMITED INVESTIGATIONS BY THE STATE AND IS IN NO WAY WARRANTED TO INDICATE THE TRUE CONDITIONS OR ACTUAL QUANTITIES OR DISTRIBUTION OF QUANTITIES OF WORK WHICH WILL BE REQUIRED.

NO.	DATE	DESCRIPTION
△	6/82	Chloride Samples Added

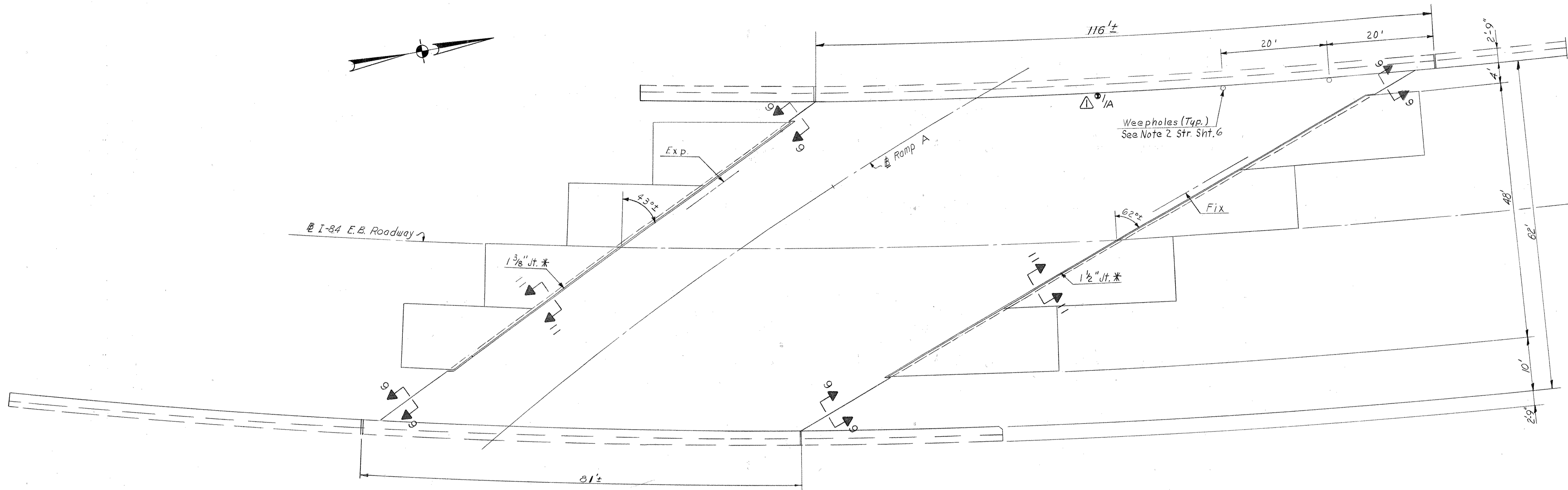

DECK PLAN - BRIDGE NO. 1749
OVER OFF RAMP FROM W.B. I-84
Scale: 1"=10'

* Jt. Dimensions Taken On 06-18-81.

CORE NO.	BR. NO. 01749			
	CHLORIDE		CONTENT	
	TOTAL	WATER SOLUBLE		
	% BY WT.	LBS./C.Y.	% BY WT.	LBS./C.Y.
1	0.034	1.333	0.030	1.176
1A	0.017	0.666		

(See Note 4 Str. Sht. 6 Date 4/1/82)

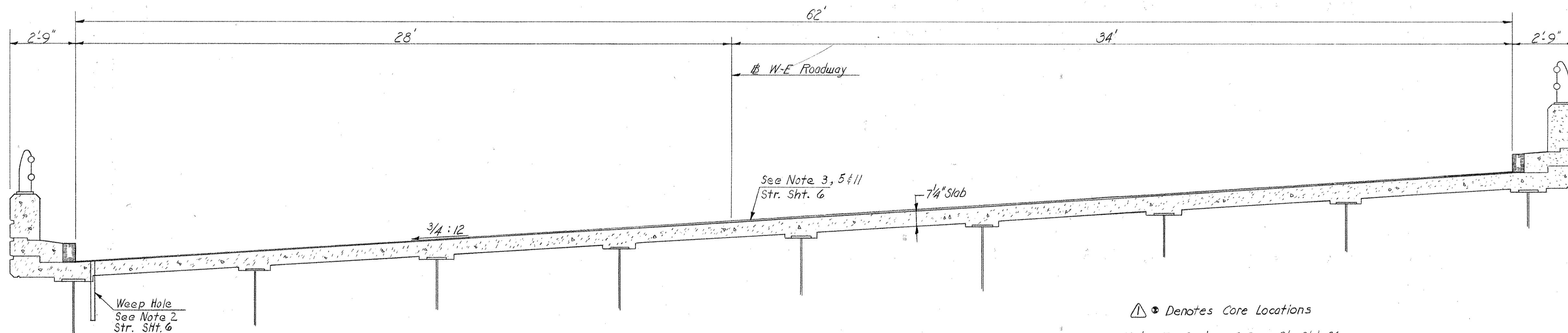

BRIDGE NO. 1749
TYPICAL CROSS SECTION
Scale: 3/8"=1'-0"

△ * Denotes Core Locations

Note: For Section 9-9 see Str. Sht. 86
For Section 11-11 see Str. Sht. 82.

Weep Hole
See Note 2
Str. Sht. 6

See Note 3, 5 & 11
Str. Sht. 6

7/4" Slab

△ 6/82 Chloride Samples Added

THE INFORMATION, INCLUDING ESTIMATED QUANTITIES OF WORK SHOWN ON THESE SHEETS IS BASED ON LIMITED INVESTIGATIONS BY THE STATE AND IS IN NO WAY WARRANTED TO INDICATE THE TRUE CONDITIONS OR ACTUAL QUANTITIES OR DISTRIBUTION OF QUANTITIES OF WORK WHICH WILL BE REQUIRED.

CONNECTICUT			
DEPARTMENT OF TRANSPORTATION			
SOUTHINGTON - HARTFORD			
INTERSTATE ROUTE 84			
59 STRUCTURES			
DECK REPAIRS			
I-84 E.B. OVER OFF RAMP FROM W.B. I-84			
ENGINEER BRIDGE DESIGN UNIT			
DESIGNER J.P.L.	DRAFTER J.J.C.	CHECKER G.D.B.	
APPROVED <i>[Signature]</i>	DATE 3/17/82		
NO. DATE	DESCRIPTION	BRIDGE LOG NO. 1749	STRUCTURE SHEET NO. 35 of 87
REVISIONS		STRUCTURE NO. 131-145-1749	

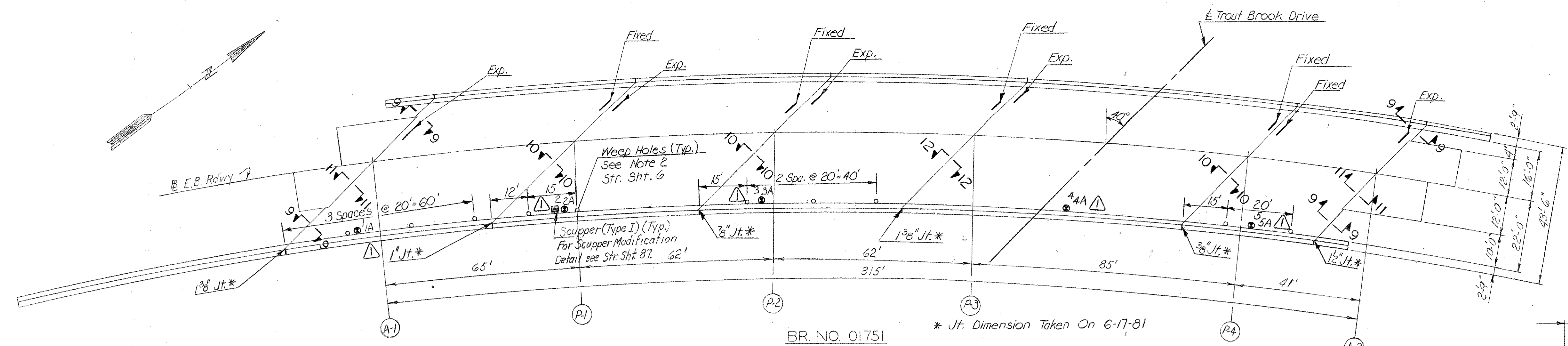

CORE NO.	BR. NO. 01751 CHLORIDE CONTENT			
	TOTAL		WATER SOLUBLE	
	% BY WT.	LBS./C.Y.	% BY WT.	LBS./C.Y.
1	0.036	1.411	0.036	1.411
1A	0.017	0.666		
2	0.063	2.470	0.055	2.158
2A	0.038	1.490		
3	0.050	1.960	0.049	1.921
3A	0.025	0.980		
4	0.079	3.097	0.073	2.862
4A	0.051	1.999		
5	0.017	0.666		
5A	0.002	0.078		

(See Note 4 Str. Sht. 6 Date 4/17/82)

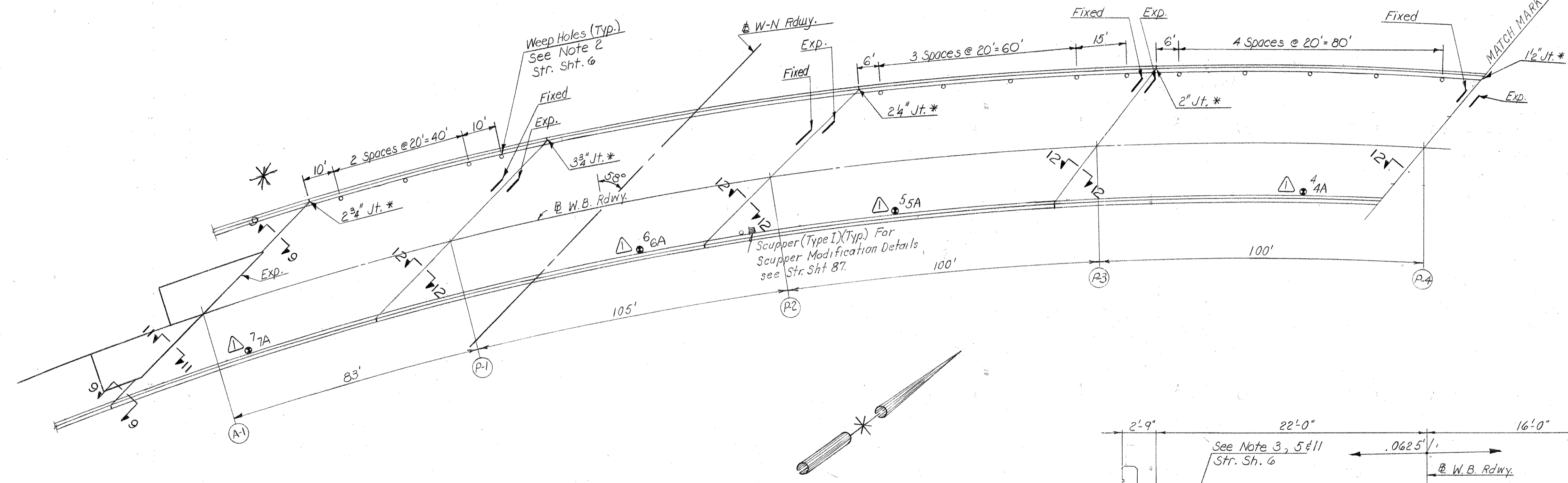
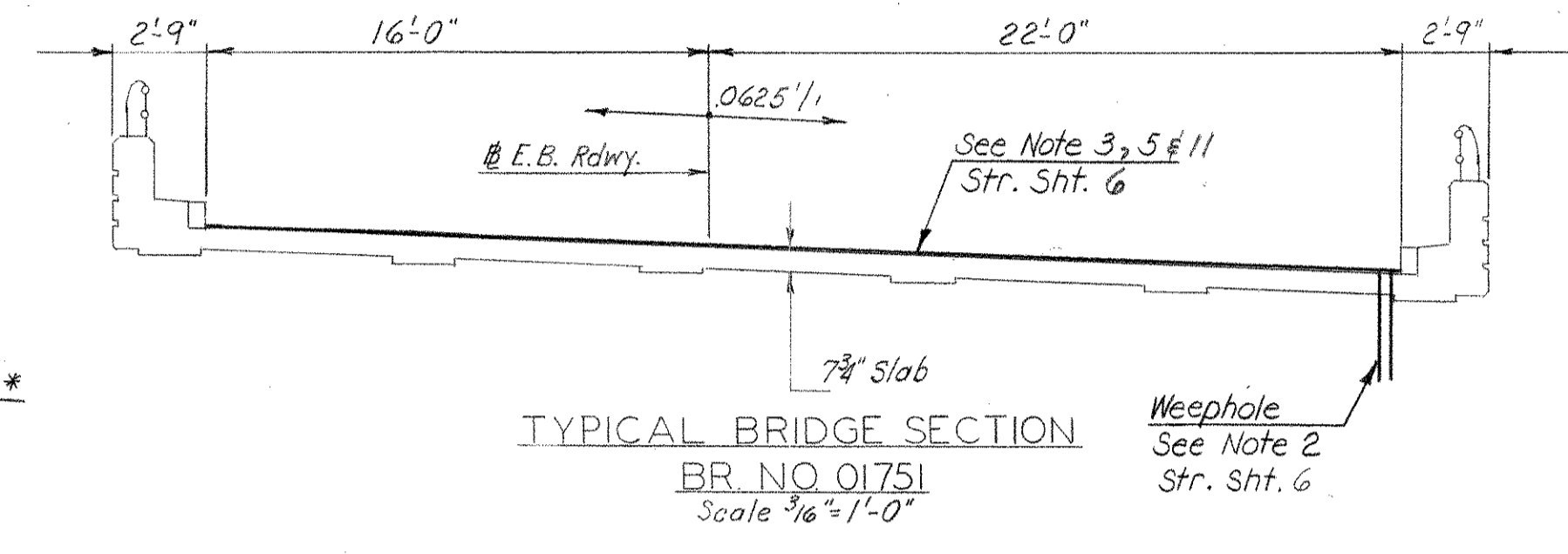

CORE NO.	BR. NO. 01752 CHLORIDE CONTENT			
	TOTAL		WATER SOLUBLE	
	% BY WT.	LBS./C.Y.	% BY WT.	LBS./C.Y.
1	0.065	2.548	0.057	2.234
1A	0.029	1.137		
2	0.078	3.058	0.067	2.626
2A	0.033	1.294		
3	0.088	3.450	0.078	3.058
3A	0.039	1.529		
4	0.018	0.706		
4A	0.003	0.118		
5	0.065	2.548	0.058	2.274
5A	0.005	0.196		
6	0.093	3.648	0.095	3.724
6A	0.060	2.352		
7	0.068	2.666	0.060	2.352
7A	0.018	0.706		

(See Note 4 Str. Sht. 6 Date 4/26/82)

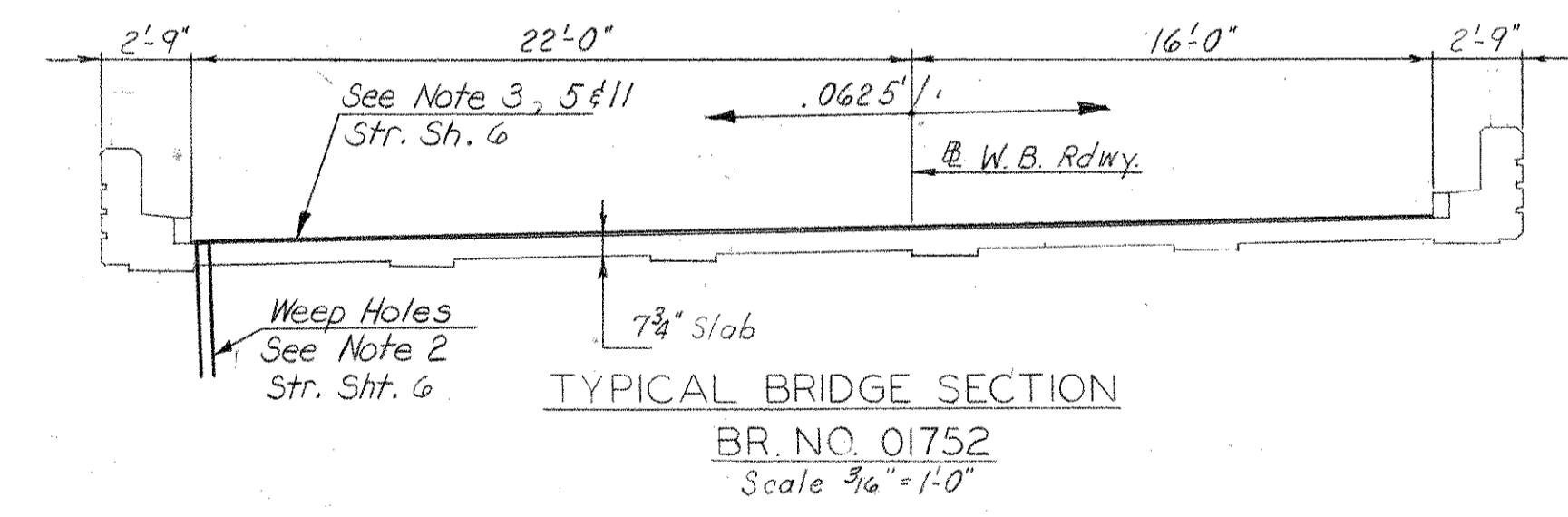

△ • Denotes Core Locations
 Note: For Sections 9-9 & 10-10, See Str. Sht. 86.
 For Sections 11-11 & 12-12, See Str. Sht. 82.

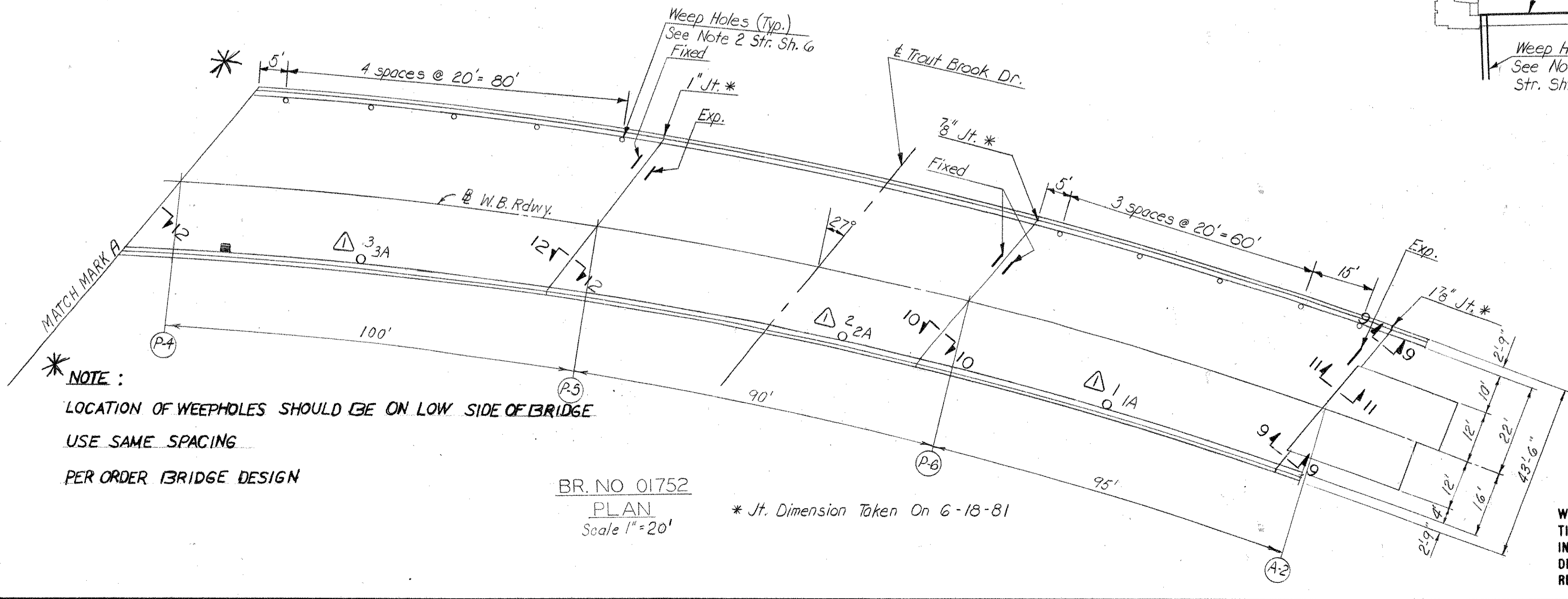

* NOTE:
 LOCATION OF WEEPHOLES SHOULD BE ON LOW SIDE OF BRIDGE
 USE SAME SPACING
 PER ORDER / BRIDGE DESIGN

THE INFORMATION, INCLUDING ESTIMATED QUANTITIES OF WORK SHOWN ON THESE SHEETS IS BASED ON LIMITED INVESTIGATIONS BY THE STATE AND IS IN NO WAY WARRANTED TO INDICATE THE TRUE CONDITIONS OR ACTUAL QUANTITIES OR DISTRIBUTION OF QUANTITIES OF WORK WHICH WILL BE REQUIRED.

CONNECTICUT
 DEPARTMENT OF TRANSPORTATION
 SOUTHINGTON - HARTFORD

INTERSTATE ROUTE 84
 59 STRUCTURES
 DECK REPAIRS

I-84 W.B. OVER TROUT BROOK DRIVE

ENGINEER BRIDGE DESIGN UNIT

DESIGNER J.P.L. DRAFTER T.S.R. CHECKER G.D.B.

APPROVED [Signature] DATE 3/17/82

NO. DATE DESCRIPTION

REVISIONS

STRUCTURE NO. 131-145-1751-1752 BRIDGE LOG NO. 1751-1752 STRUCTURE SHEET NO. 36-87

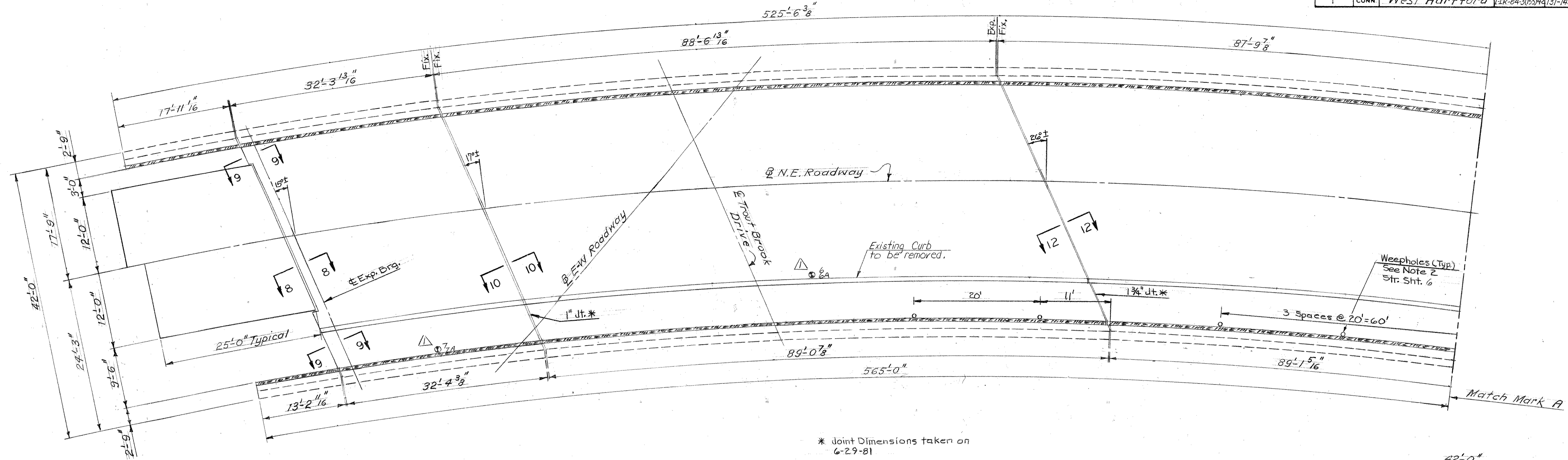

* Joint Dimensions taken on 6-29-81

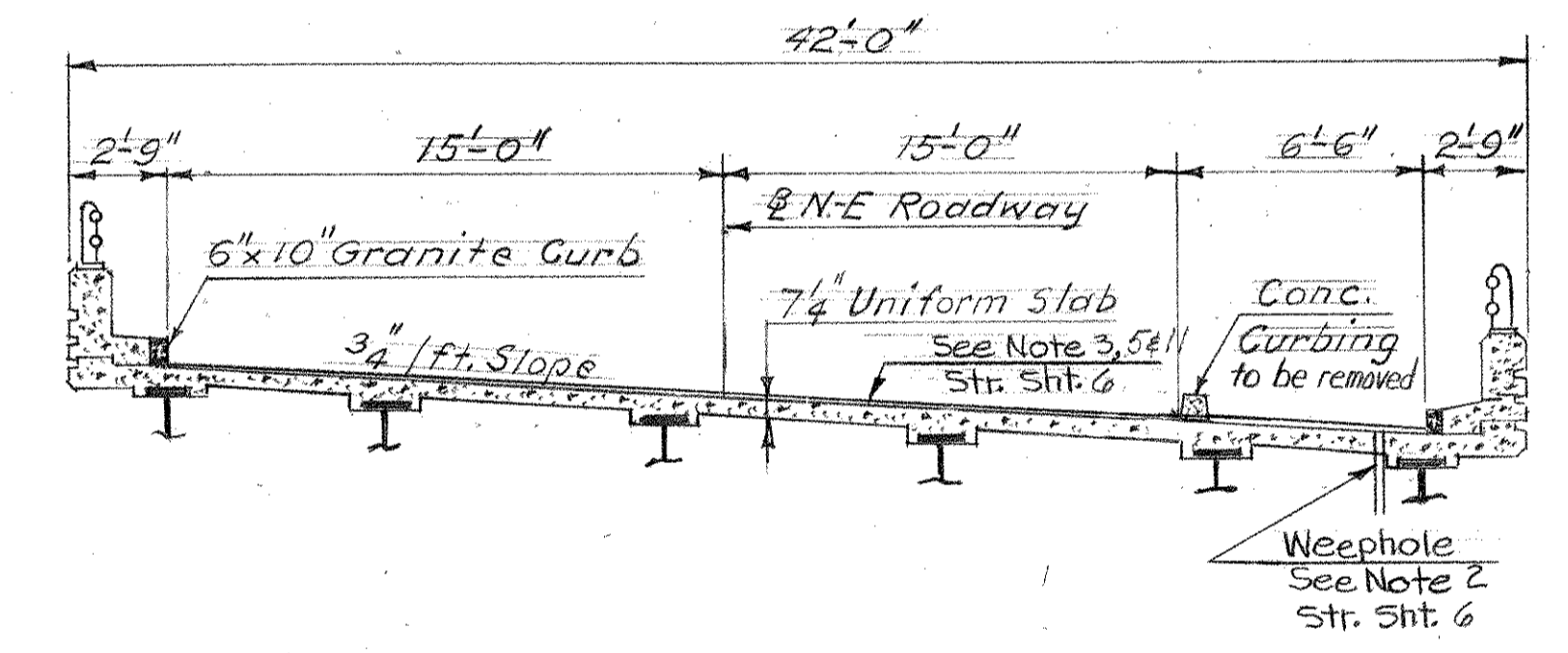

TYPICAL BRIDGE SECTION
Scale: 3/16" = 1'-0"

△• Denotes Core Locations
Note: For Sections 8-8, 9-9 & 10-10, see Str. Sht. 86.
For Section 12-12, see Str. Sht. 82.

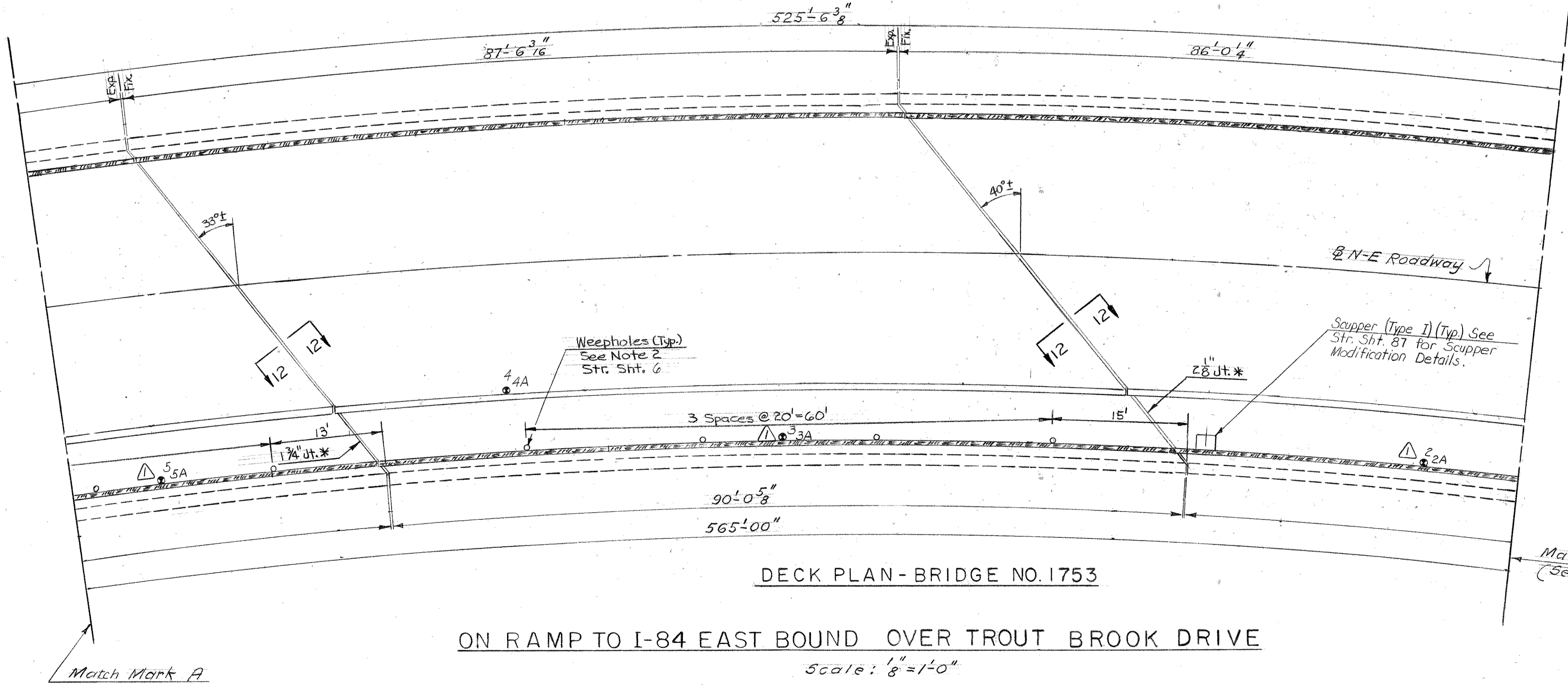

DECK PLAN - BRIDGE NO. 1753
ON RAMP TO I-84 EAST BOUND OVER TROUT BROOK DRIVE
Scale: 1/8" = 1'-0"

THE INFORMATION, INCLUDING ESTIMATED QUANTITIES OF WORK SHOWN ON THESE SHEETS IS BASED ON LIMITED INVESTIGATIONS BY THE STATE AND IS IN NO WAY WARRANTED TO INDICATE THE TRUE CONDITIONS OR ACTUAL QUANTITIES OR DISTRIBUTION OF QUANTITIES OF WORK WHICH WILL BE REQUIRED.

△	6/82	Chloride Samples Added

CONNECTICUT DEPARTMENT OF TRANSPORTATION			
SOUTHINGTON - HARTFORD			
INTERSTATE ROUTE 84			
59 STRUCTURES			
DECK REPAIRS			
ON RAMP TO I-84 E.B. OVER TROUT BROOK DRIVE			
ENGINEER BRIDGE DESIGN UNIT			
DESIGNER	J.P.L.	DRAFTER	G.O.K.
CHECKER	G.D.B.	APPROVED	<i>[Signature]</i>
NO.	DATE	DESCRIPTION	DATE

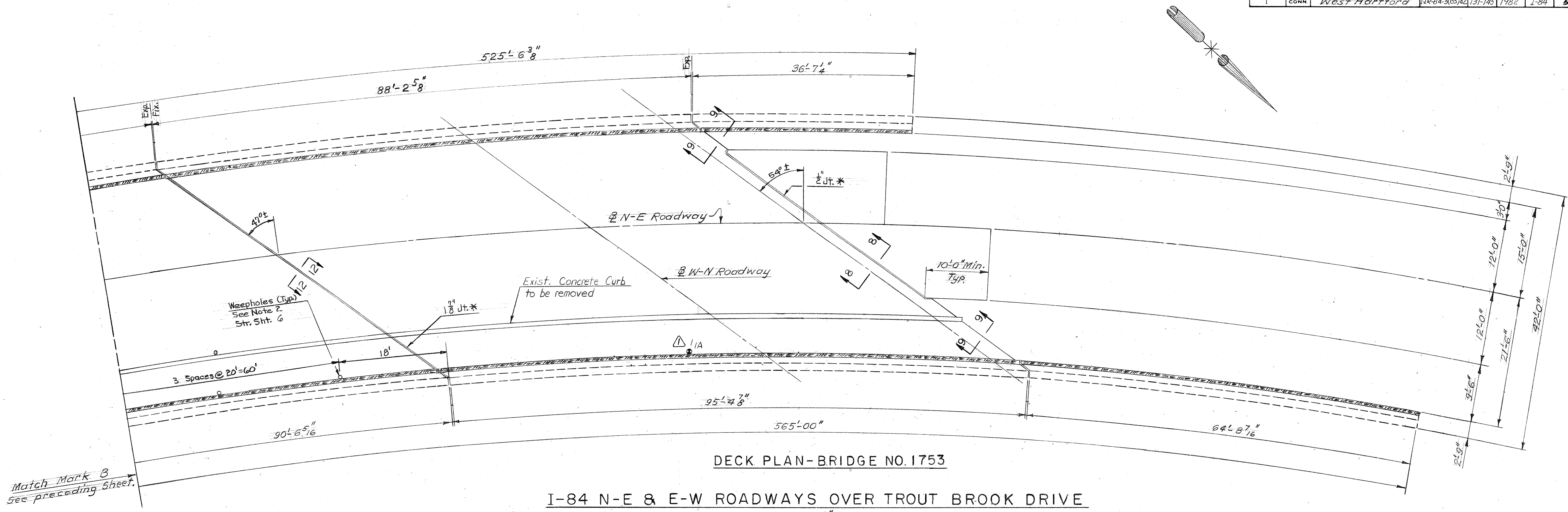

DECK PLAN-BRIDGE NO. 1753
 I-84 N-E & E-W ROADWAYS OVER TROUT BROOK DRIVE
 Scale: 1/8" = 1'-0"

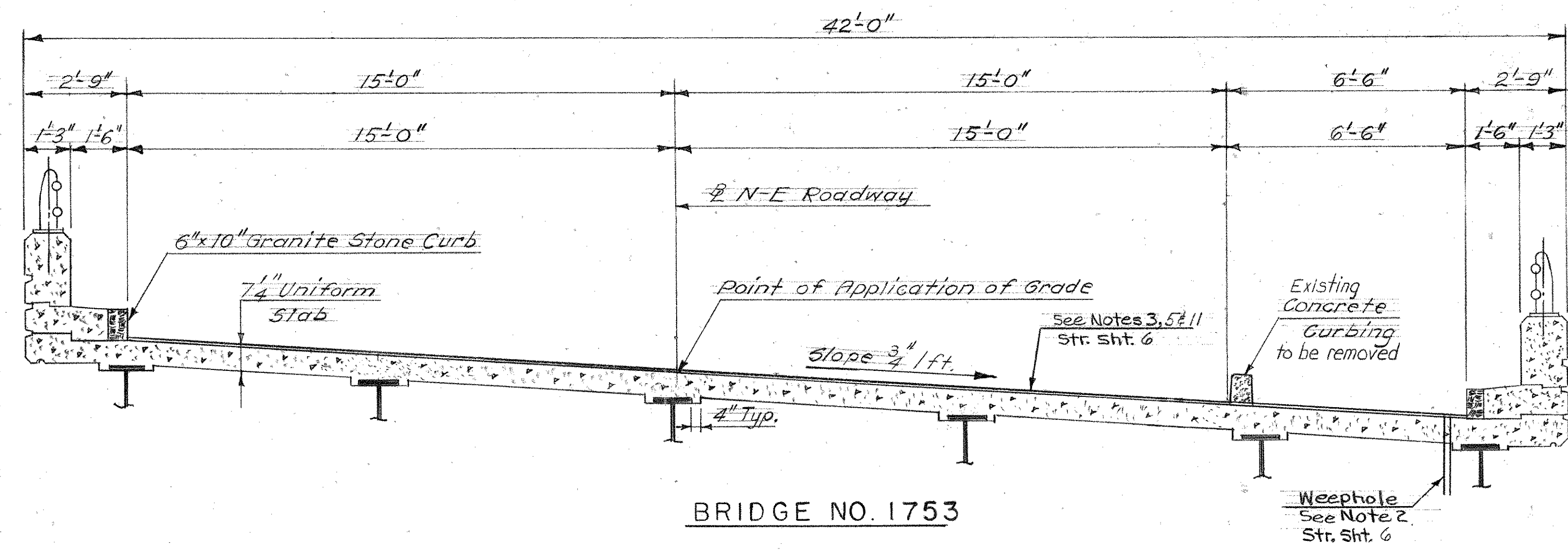

BRIDGE NO. 1753
 TYPICAL BRIDGE SECTION
 Scale: 3/8" = 1'-0"

△ • Denotes Core Locations
 * Joint Dimensions taken on 6-29-81

BR. NO. 01753

CORE NO.	CHLORIDE CONTENT		WATER SOLUBLE	
	% BY WT	LBS./C.Y.	% BY WT	LBS./C.Y.
1	0.061	2.391	0.055	2.156
1A	0.002	0.078		
2	0.006	0.235		
2A	0.003	0.118		
3	0.004	0.157		
3A	0.004	0.157		
4	0.064	2.509	0.056	2.195
4A	0.003	1.118		
5	0.022	0.862	0.017	0.666
5A	0.004	0.157		
6	0.017	0.666		
6A	0.002	0.078		
7	0.001	0.039		
7A	0.000	0.000		

Note: For Sections 8-8 & 9-9, See Str. Sht. 86
 For Section 12-12, see Str. Sht. 82.

Note: Removal of existing concrete curbing to be paid for under the item "Removal of Doweled Concrete Curbing (Bridge)".

THE INFORMATION, INCLUDING ESTIMATED QUANTITIES OF WORK SHOWN ON THESE SHEETS IS BASED ON LIMITED INVESTIGATIONS BY THE STATE AND IS IN NO WAY WARRANTED TO INDICATE THE TRUE CONDITIONS OR ACTUAL QUANTITIES OR DISTRIBUTION OF QUANTITIES OF WORK WHICH WILL BE REQUIRED.

6/82	Chloride Samples Added

CONNECTICUT DEPARTMENT OF TRANSPORTATION		
SOUTHINGTON - HARTFORD		
INTERSTATE ROUTE 84 59 STRUCTURES DECK REPAIRS		
ON RAMP TO I-84 E.B. OVER TROUT BROOK DRIVE		
ENGINEER BRIDGE DESIGN UNIT		
DESIGNER J.P.L.	DRAFTER G.O.K.	CHECKER G.D.B.
APPROVED <i>[Signature]</i>	DATE 3/17/82	
NO. DATE	DESCRIPTION	BRIDGE LOG NO. STRUCTURE SHEET NO.
		1753 38 of 87

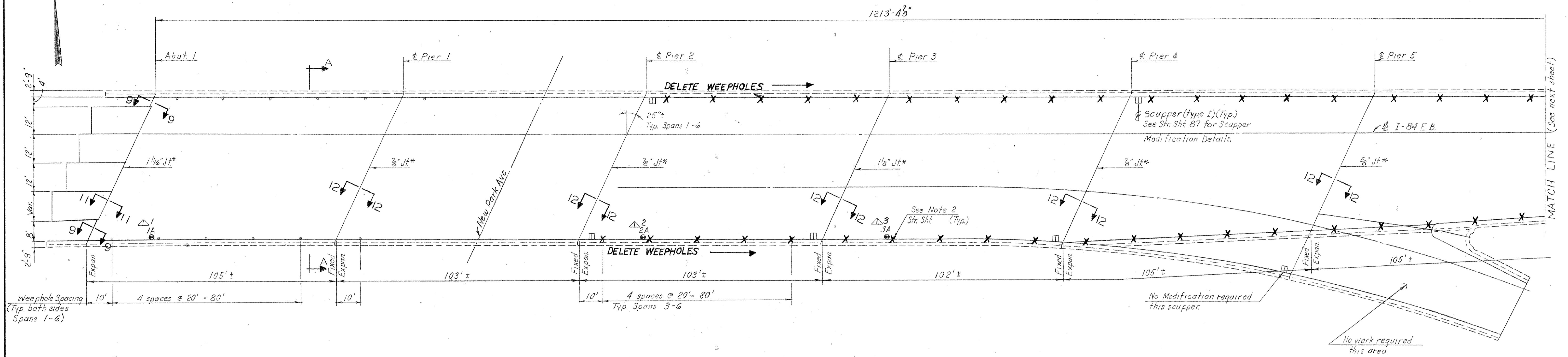

DECK PLAN
BR. NO. 3367
Scale 1"=20'

* Jt dimensions taken 09/03/81 (Temp 77°)

CORE NO.	CHLORIDE CONTENT		WATER SOLUBLE	
	% BY WT	LBS/CY	% BY WT	LBS/CY
See Note 4 Str. Sht. 6 Date 4/26/82				
1	0.004	0.157		
1A	0.003	0.118		
2	0.004	0.157		
2A	0.003	0.118		
3	0.007	0.274		
3A	0.002	0.078		
4	0.018	0.706	0.015	0.588
4A	0.003	0.118		
5	0.004	0.157		
5A	0.004	0.157		
6	0.002	0.078		
6A	0.003	0.118		
7	0.003	0.118		
7A	0.003	0.118		
8	0.002	0.078		
8A	0.001	0.039		
9	0.003	0.118		
9A	0.002	0.078		

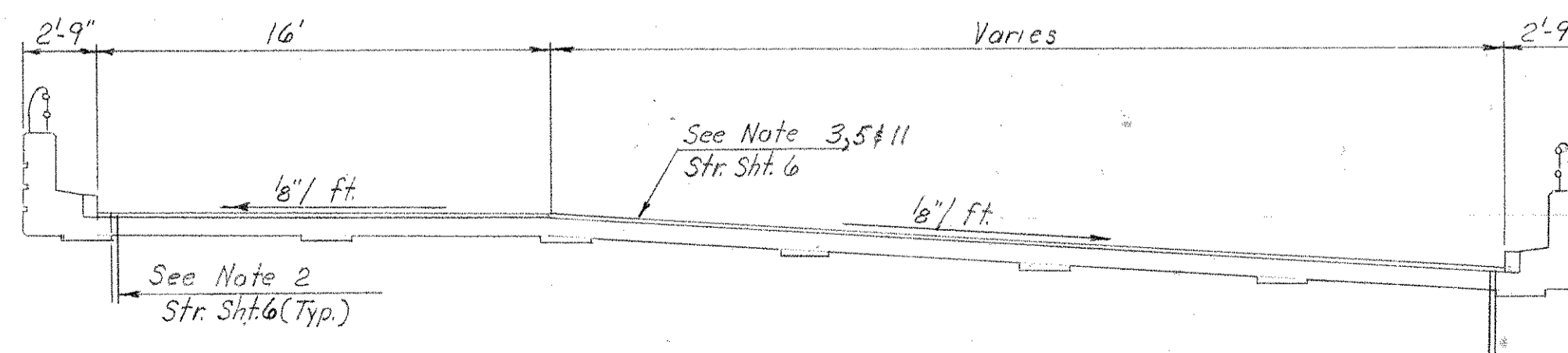
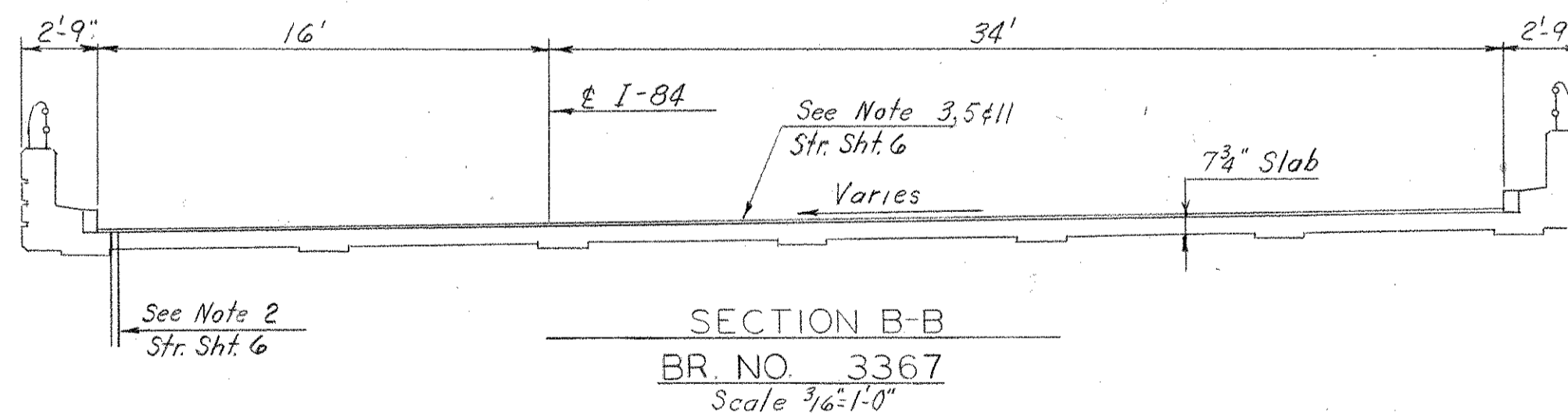

SECTION A-A
BR. NO. 3367
Scale 3/4"=1'-0"

Note: For Section 9-9 see Str. Sht. 86
For Sections 11-11 & 12-12 see Str. Sht. 82
△ ● Denotes Core Location

CONNECTICUT DEPARTMENT OF TRANSPORTATION			
SOUTHINGTON - HARTFORD			
INTERSTATE ROUTE 84			
59 STRUCTURES			
DECK REPAIRS			
I-84 E.B. OVER S.B. SR 504 & R.R.			
ENGINEER		BRIDGE DESIGN UNIT	
DESIGNER	J. P. L.	DRAFTER	T. S. R.
CHECKER	G. D. B.		
NO.	DATE	DESCRIPTION	APPROVED
6-82		Chloride samples added	<i>[Signature]</i>
REVISIONS		STRUCTURE NO. 131-145-3367	DATE 3/17/82
		BRIDGE LOG NO. 3367	STRUCTURE SHEET NO. 40 of 87

THE INFORMATION, INCLUDING ESTIMATED QUANTITIES OF WORK SHOWN ON THESE SHEETS IS BASED ON LIMITED INVESTIGATIONS BY THE STATE AND IS IN NO WAY WARRANTED TO INDICATE THE TRUE CONDITIONS OR ACTUAL QUANTITIES OR DISTRIBUTION OF QUANTITIES OF WORK WHICH WILL BE REQUIRED.

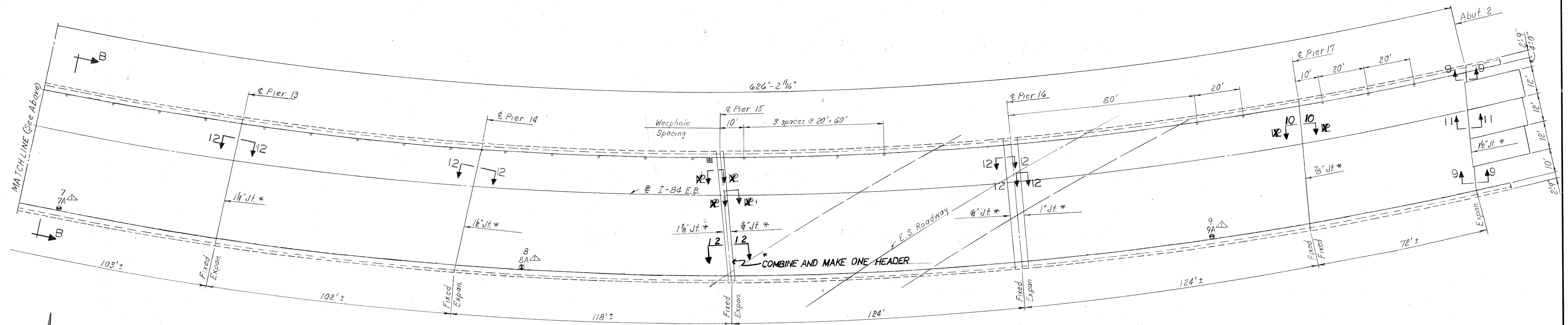
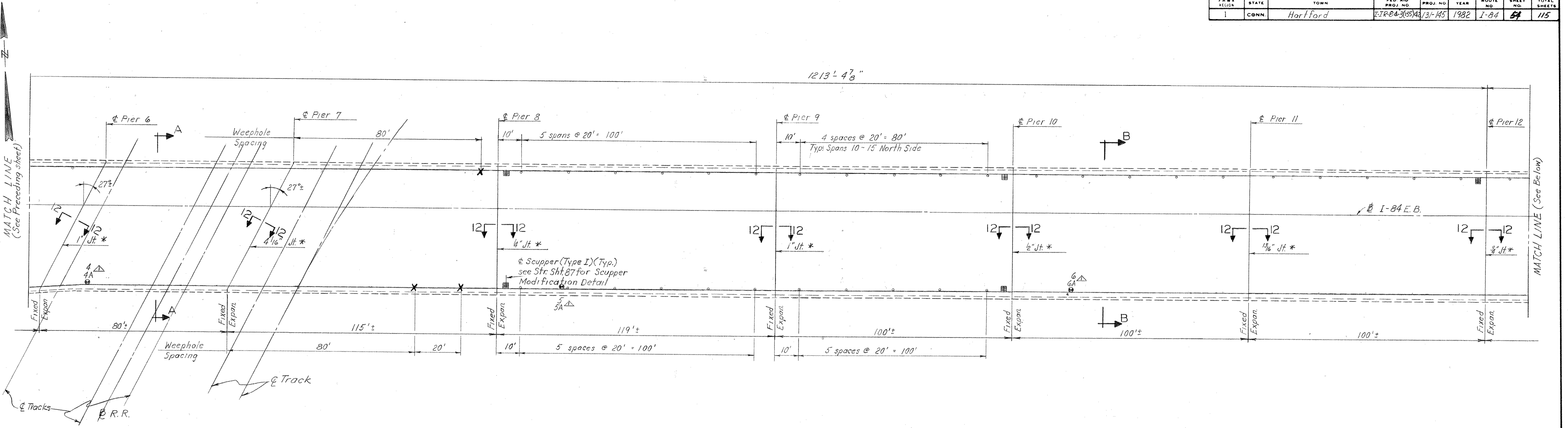

DECK PLAN
BR. NO. 3367
Scale 1"=20'

*Jt. dimensions taken 9/03/81 (Temp 77°)

Note: For Section 9-9 see Str. Sht. 86
For Sections 11-11 & 12-12 see Str. Sht. 82.
△ ⊙ Denotes Core Location

THE INFORMATION, INCLUDING ESTIMATED QUANTITIES OF WORK SHOWN ON THESE SHEETS IS BASED ON LIMITED INVESTIGATIONS BY THE STATE AND IS IN NO WAY WARRANTED TO INDICATE THE TRUE CONDITIONS OR ACTUAL QUANTITIES OR DISTRIBUTION OF QUANTITIES OF WORK WHICH WILL BE REQUIRED.

CONNECTICUT DEPARTMENT OF TRANSPORTATION			
SOUTHINGTON - HARTFORD			
INTERSTATE ROUTE 84			
59 STRUCTURES			
DECK REPAIRS			
I-84 E.B. OVER S.B. SR 504 & R.R.			
ENGINEER		BRIDGE DESIGN UNIT	
DESIGNER	J. P. L.	DRAFTER	T. S. R.
CHECKER	G. D. B.	DATE 3/17/82	
NO.	DATE	DESCRIPTION	APPROVED
REVISIONS		STRUCTURE NO. 131-145-3367	BRIDGE LOG NO. 3367
			STRUCTURE SHEET NO. 41 of 87

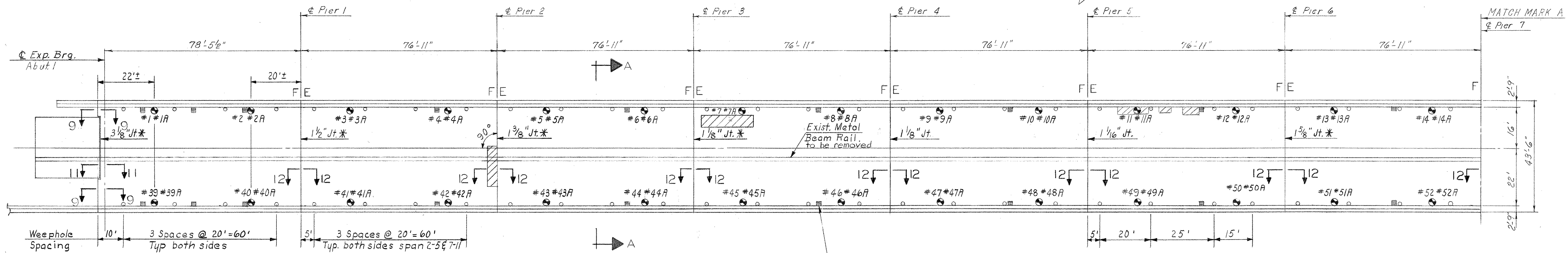

Scupper (Type I) (Typ.) see Str. Sht. 87 for Scupper Modification Details.

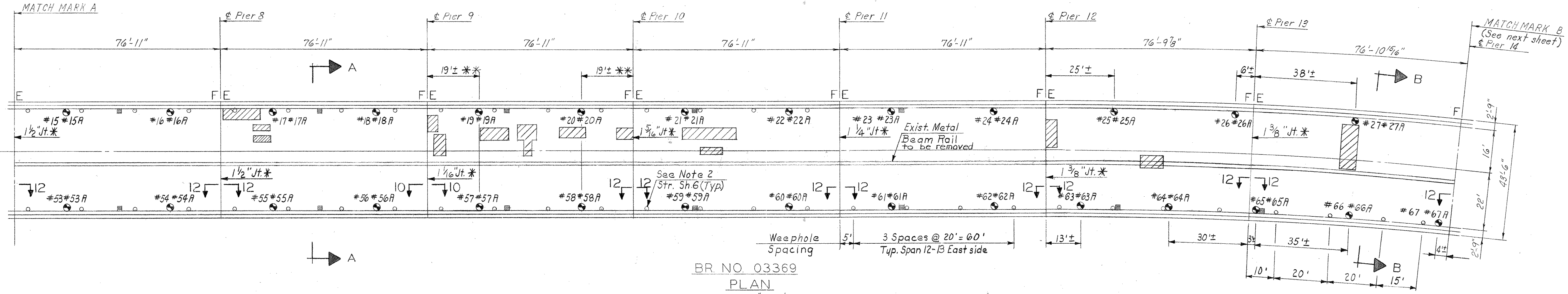

BR. NO. 03369
PLAN
Scale 1" = 20'

** Typical spacing except where shown otherwise.

● Denotes Core Location
* Jt. dimensions 10/22/81 (Temp 57°)
Deck survey done 9/18/81
Note: See Str. Sh. 45 for chloride analysis.
For Section 9-9 see str. sht. 86.
For Section 11-11, 12-12 see Str. Sh. 82.

Removal of Metal Beam Rail to be paid for under "Remove Metal Beam Rail (Bridge)"

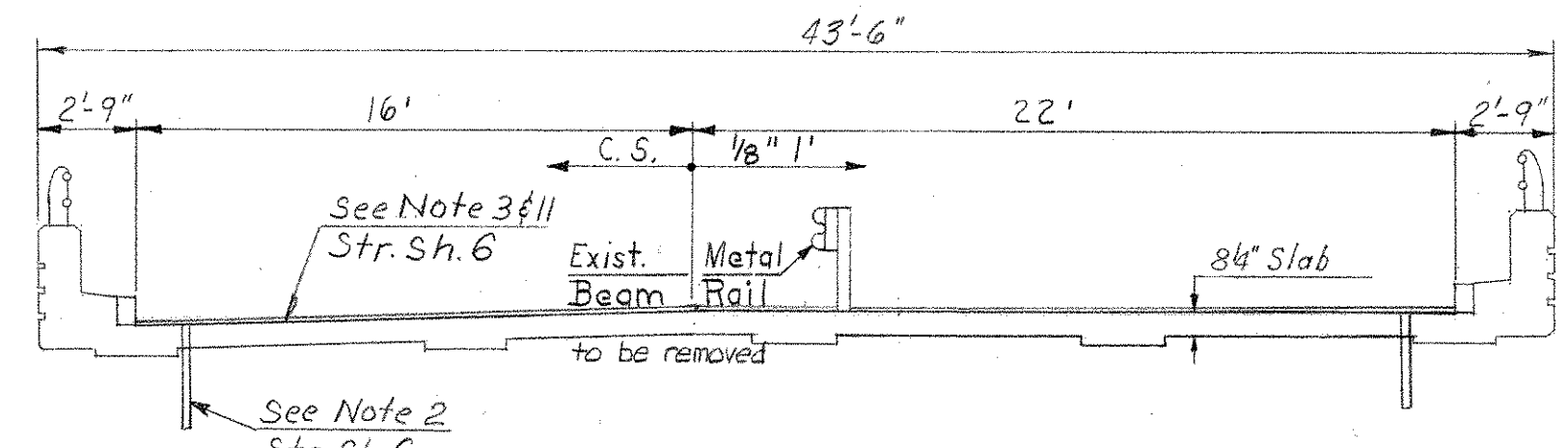

SECTION A-A
Scale 3/16" = 1'-0"

CONNECTICUT DEPARTMENT OF TRANSPORTATION		
SOUTHINGTON - HARTFORD		
INTERSTATE ROUTE 84		
59 STRUCTURES		
DECK REPAIRS		
FLATBUSH AVE. ON RAMP TO I-84 E.B.		
ENGINEER BRIDGE DESIGN UNIT		
DESIGNER J.P.L.	DRAFTER T.S.R.	CHECKER G.D.B.
APPROVED [Signature]	DATE 3/17/82	
NO. DATE	DESCRIPTION	APPROVED
REVISIONS		STRUCTURE NO. 131-145-3369
		BRIDGE LOG NO. 3369
		STRUCTURE SHEET NO. 43 of 87

THE INFORMATION, INCLUDING ESTIMATED QUANTITIES OF WORK SHOWN ON THESE SHEETS IS BASED ON LIMITED INVESTIGATIONS BY THE STATE AND IS IN NO WAY WARRANTED TO INDICATE THE TRUE CONDITIONS OR ACTUAL QUANTITIES OR DISTRIBUTION OF QUANTITIES OF WORK WHICH WILL BE REQUIRED.

BR. NO. 3368

CORE NO.	CHLORIDE TOTAL		CONTENT WATER SOLUBLE	
	% BY WT. LBS./CY.		% BY WT. LBS./CY.	
	(See Note 4 Str. Sht. 6 Date 9/8/81)			
1	0.013	0.510		
1A	0.007	0.274		
2	0.059	2.313		
2A	0.008	0.314		
3	0.113	4.430	0.106	4.155
3A	0.020	0.784		
4	0.007	0.274		
4A	0.006	0.235		
5	0.008	0.314		
5A	0.007	0.274		
6	0.007	0.274		
6A	0.005	0.196		
7	0.007	0.274		
7A	0.007	0.274		
8	0.018	0.706		
8A	0.007	0.274		
9	0.082	3.214		
9A	0.021	0.823		
10	0.007	0.274		
10A	0.004	0.157		
11	0.017	4.586	0.105	4.116
11A	0.018	0.706		
12	0.042	1.646		
12A	0.007	0.274		
13	0.018	0.706		
13A	0.010	0.392		
14	0.019	0.744		
14A	0.007	0.274		
15	0.068	2.666		
15A	0.046	1.803		
16	0.040	1.568		
16A	0.032	1.254		
17	0.061	2.391		
17A	0.037	1.450		
18	0.037	1.450		
18A	0.030	1.176		
19	0.024	0.941		
19A	0.010	0.392		
20	0.037	1.450		
20A	0.006	0.235		
21	0.011	0.431		
21A	0.006	0.235		
22	0.017	0.666		
22A	0.006	0.235		
23	0.055	2.156		
23A	0.047	1.842		
24	0.008	0.314		
24A	0.006	0.235		
25	0.006	0.235		
25A	0.005	0.196		
26	0.005	0.196		
26A	0.005	0.196		
27	0.019	0.745		
27A	0.006	0.235		
28	0.064	2.509		
28A	0.023	0.902		
29	0.005	0.196		
29A	0.005	0.196		
30	0.005	0.196		
30A	0.004	0.157		
31	0.039	1.529		
31A	0.005	0.196		
32	0.088	3.450	0.079	3.097
32A	0.018	0.706		
33	0.011	0.431		
33A	0.003	0.118		
34	0.003	0.118		
34A	0.003	0.118		
35	0.008	0.314		
35A	0.003	0.118		
36	0.004	0.157		
36A	0.002	0.078		
37	0.004	0.157		
37A	0.003	0.118		
38	0.005	0.196		
38A	0.004	0.157		

BR. NO. 3368

39	0.004	0.157		
39A	0.004	0.157		
40	0.004	0.157		
40A	0.004	0.157		
41	0.004	0.157		
41A	0.004	0.157		
42	0.018	0.706		
42A	0.004	0.157		

BR. NO. 3369

CORE NO.	CHLORIDE TOTAL		CONTENT WATER SOLUBLE	
	% BY WT. LBS./CY.		% BY WT. LBS./CY.	
	(See Note 4 Str. Sht. 6 Date 10/9/81)			
1	0.043	1.686		
1A	0.009	0.353		
2	0.019	0.745		
2A	0.005	0.196		
3	0.149	5.841	0.147	5.762
3A	0.049	1.921		
4	0.138	5.410		
4A	0.083	3.254		
5	0.198	7.762	0.186	7.291
5A	0.134	5.253		
6	0.167	6.546		
6A	0.032	1.254		
7	0.150	5.880		
7A	0.093	3.640		
8	0.163	6.370	0.156	6.115
8A	0.072	2.822		
9	0.155	6.076		
9A	0.056	2.195		
10	0.144	5.645		
10A	0.091	3.567		
11	0.115	4.508		
11A	0.079	3.097		
12	0.220	8.624	0.199	7.801
12A	0.124	4.861		
13	0.106	4.155		
13A	0.049	1.921		
14	0.167	6.546		
14A	0.090	3.528		
15	0.129	5.057	0.128	5.018
15A	0.020	0.784		
16	0.047	1.842		
16A	0.007	0.274		
17	0.024	0.941		
17A	0.003	0.118		
18	0.071	2.783		
18A	0.005	0.196		
19	0.157	6.154	0.142	5.562
19A	0.008	0.314		
20	0.088	3.450		
20A	0.006	0.235		
21	0.062	2.430		
21A	0.006	0.235		
22	0.120	4.704	0.109	4.273
22A	0.004	0.157		
23	0.064	2.509		
23A	0.006	0.235		
24	0.023	0.902		
24A	0.004	0.157		
25	0.045	1.764		
25A	0.006	0.235		
26	0.017	0.666		
26A	0.004	0.157		
27	0.053	2.078		
27A	0.022	0.862		
28	0.021	0.823		
28A	0.006	0.235		
29	0.063	2.470		
29A	0.006	0.235		
30	0.030	1.176		
30A	0.005	0.196		
31	0.024	0.941		
31A	0.004	0.157		
32	0.034	1.333		
32A	0.006	0.235		
33	0.081	3.175	0.061	2.391
33A	0.041	1.607		
34	0.052	2.038		
34A	0.006	0.235		
35	0.068	2.666		
35A	0.006	0.235		
36	0.136	5.331	0.128	5.018

BR. NO. 3369

36A	0.008	0.314		
37	0.040	1.568		
37A	0.004	0.157		
38	0.072	2.822		
38A	0.006	0.235		
39	0.021	0.823		
39A	0.005	0.196		
40	0.012	0.470		
40A	0.005	0.196		
41	0.041	1.607		
41A	0.005	0.196		
42	0.039	1.529		
42A	0.005	0.196		
43	0.036	1.411		
43A	0.006	0.235		
44	0.009	0.353		
44A	0.004	0.157		
45	0.029	1.137		
45A	0.004	0.157		
46	0.041	1.607		
46A	0.004	0.157		
47	0.025	0.980		
47A	0.004	0.157		
48	0.022	0.862		
48A	0.003	0.118		
49	0.026	1.019		
49A	0.005	0.196		
50	0.028	1.098		
50A	0.004	0.157		
51	0.027	1.058		
51A	0.005	0.196		
52	0.015	0.588		
52A	0.004	0.157		
53	0.017	0.666		
53A	0.003	0.118		
54	0.012	0.470		
54A	0.002	0.078		
55	0.017	0.666		
55A	0.004	0.157		
56	0.019	0.745		
56A	0.003	0.118		
57	0.040	1.568		
57A	0.004	0.157		
58	0.052	2.038	0.048	1.882
58A	0.003	0.118		
59	0.042	1.646		
59A	0.002	0.078		
60	0.044	1.725		
60A	0.003	0.118		
61	0.020	0.784		
61A	0.003	0.118		
62	0.020	0.864		
62A	0.004	0.157		
63	0.011	0.431		
63A	0.004	0.157		
64	0.037	1.450		
64A	0.004	0.157		
65	0.018	0.706		
65A	0.004	0.157		
66	0.006	0.235		
66A	0.004	0.157		
67	0.023	0.902		
67A	0.003	0.118		
68	0.042	1.646		
68A	0.003	0.118		
69	0.030	1.176		
69A	0.005	0.196		
70	0.015	0.588		
70A	0.003	0.118		
71	0.037	1.450		
71A	0.004	0.157		

FHW REGION	STATE	TOWN	FED. AID PROJ. NO.	PROJ. NO.	YEAR	ROUTE NO.	SHEET NO.	TOTAL SHEETS
1	CONN.	Hartford	FJR-81-3(15)42	31-145	1982	I-84	58	115

BR. NO. 3369

72	0.023	0.902		
72A	0.003	0.118		
73	0.006	0.235		
73A	0.003	0.118		
74	0.022	0.862		
74A	0.003	0.118		
75	0.004	0.157		
75A	0.004	0.157		
76	0.005	0.196		
76A	0.004	0.157		
77	0.010	0.392		
77A	0.003	0.118		
78	0.008	0.314		
78A	0.002	0.078		
79	0.026	1.019		
79A	0.011	0.431		
80	0.014	0.549		
80A	0.014	0.549		

STATE OF CONNECTICUT
DEPARTMENT OF TRANSPORTATION
SOUTHINGTON - HARTFORD

INTERSTATE ROUTE 84
59 STRUCTURES
DECK REPAIRS
BR. NO. 3368 & 3369 - CHLORIDE TABLES

ENGINEER BRIDGE DESIGN UNIT
DESIGNER G.D.B. DRAFTER R.G. CHECKER G.D.B.
APPROVED *[Signature]* DATE 3/17/82
STRUCTURE NO. 31-145-3368 & 3369 BRIDGE LOG NO. 3368 & 3369 STRUCTURE SHEET NO. 45 OF 87

THE INFORMATION, INCLUDING ESTIMATED QUANTITIES OF WORK SHOWN ON THESE SHEETS IS BASED ON LIMITED INVESTIGATIONS BY THE STATE AND IS IN NO WAY WARRANTED TO INDICATE THE TRUE CONDITIONS OR ACTUAL QUANTITIES OR DISTRIBUTION OF QUANTITIES OF WORK WHICH WILL BE REQUIRED.

NO.	DATE	DESCRIPTION
		REVISIONS

F.H.W.A. REGION	STATE	TOWN	FED. AID PROJ. NO.	PROJ. NO.	YEAR	ROUTE NO.	SHEET NO.	TOTAL SHEETS
1	CONN.	Hartford	HR-84-3(55)-42	131-145	1982	I-84	57	115

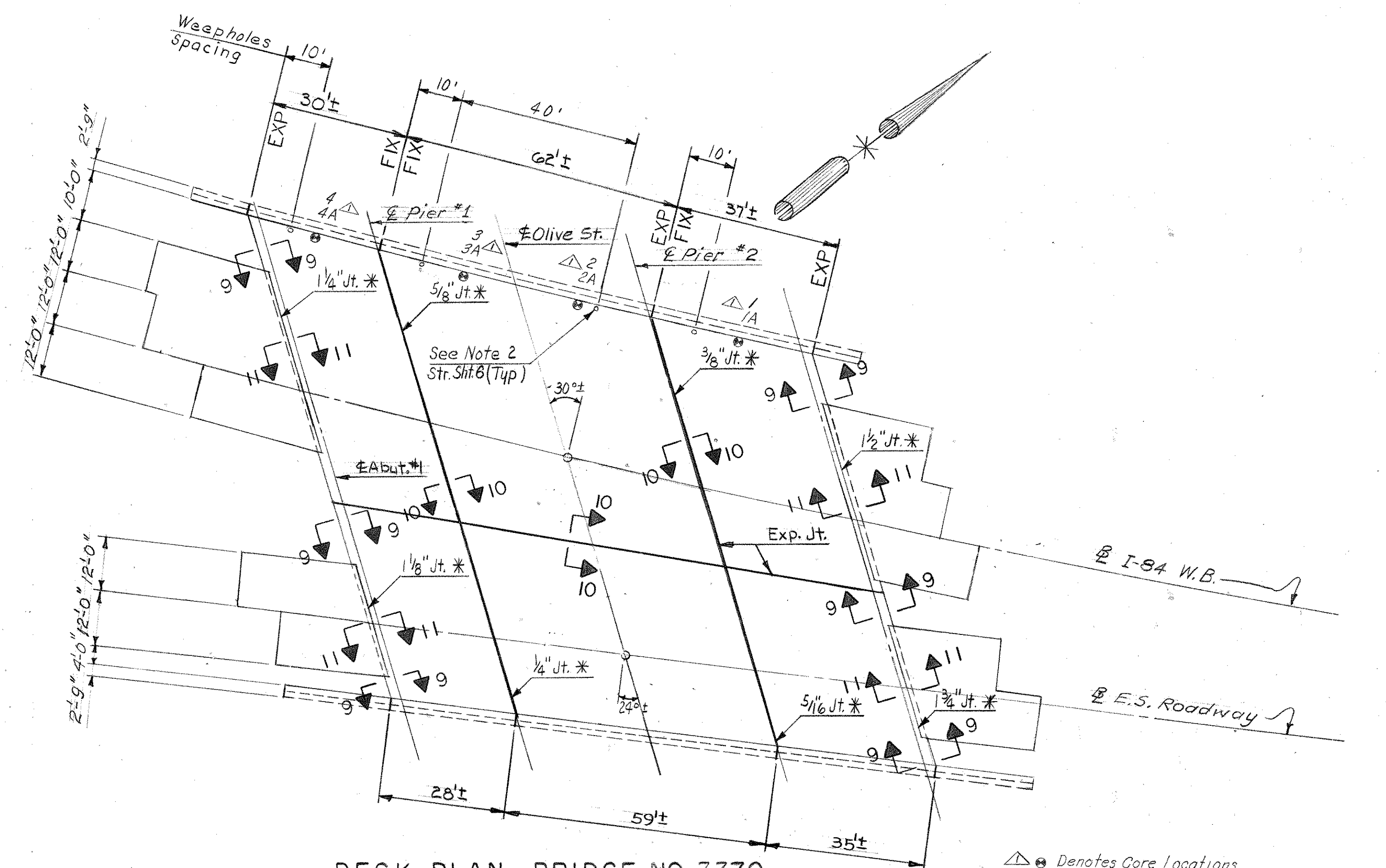

DECK PLAN - BRIDGE NO. 3370
I-84 OVER OLIVE STREET
 Scale: 1"=20'

△ Denotes Core Locations
 * Jt. dimensions taken 7/13/81 (Temp 82°)

03370

CORE NO.	△ CHLORIDE CONTENT			
	TOTAL		WATER SOLUBLE	
	% BY WT. LBS./CY.	% BY WT. LBS./CY.	% BY WT. LBS./CY.	% BY WT. LBS./CY.
See Note 4 Str. Sht. 6. Date 5/17/82				
1	0.034	1.335	0.029	1.137
1A	0.005	0.196		
2	0.031	1.215	0.027	1.058
2A	0.018	0.706		
3	0.024	0.941		
3A	0.007	0.274		
4	0.018	0.706		
4A	0.005	0.196		

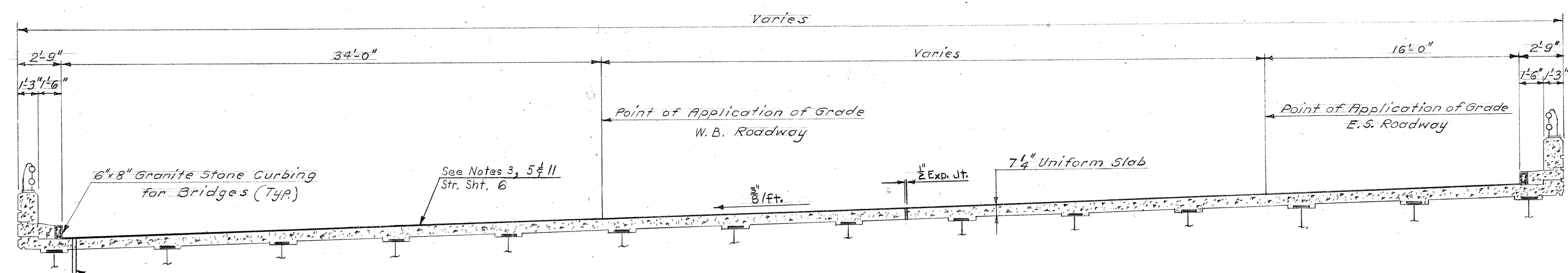

BRIDGE NO. 3370
TYPICAL BRIDGE SECTION
 Scale: 1/4"=1'-0"

Note: For Sections 9-9 & 10-10 see Str. Sht. 86.
 For Section 11-11 see Str. Sht. 82.

CONNECTICUT		
DEPARTMENT OF TRANSPORTATION		
SOUTHINGTON-HARTFORD		
INTERSTATE ROUTE 84		
59 STRUCTURES		
DECK REPAIRS		
I-84 W.B. OVER OLIVE ST.		
ENGINEER Bridge Design Unit		
DESIGNER J.P.L.	DRAFTER G.O.K.	CHECKER G.D.B.
APPROVED <i>[Signature]</i>	DATE 3/17/82	
STRUCTURE NO. 131-145-3370		BRIDGE LOG NO. 3370
REVISIONS		STRUCTURE SHEET NO. 46 of 87

THE INFORMATION, INCLUDING ESTIMATED QUANTITIES OF WORK SHOWN ON THESE SHEETS IS BASED ON LIMITED INVESTIGATIONS BY THE STATE AND IS IN NO WAY WARRANTED TO INDICATE THE TRUE CONDITIONS OR ACTUAL QUANTITIES OR DISTRIBUTION OF QUANTITIES OF WORK WHICH WILL BE REQUIRED.

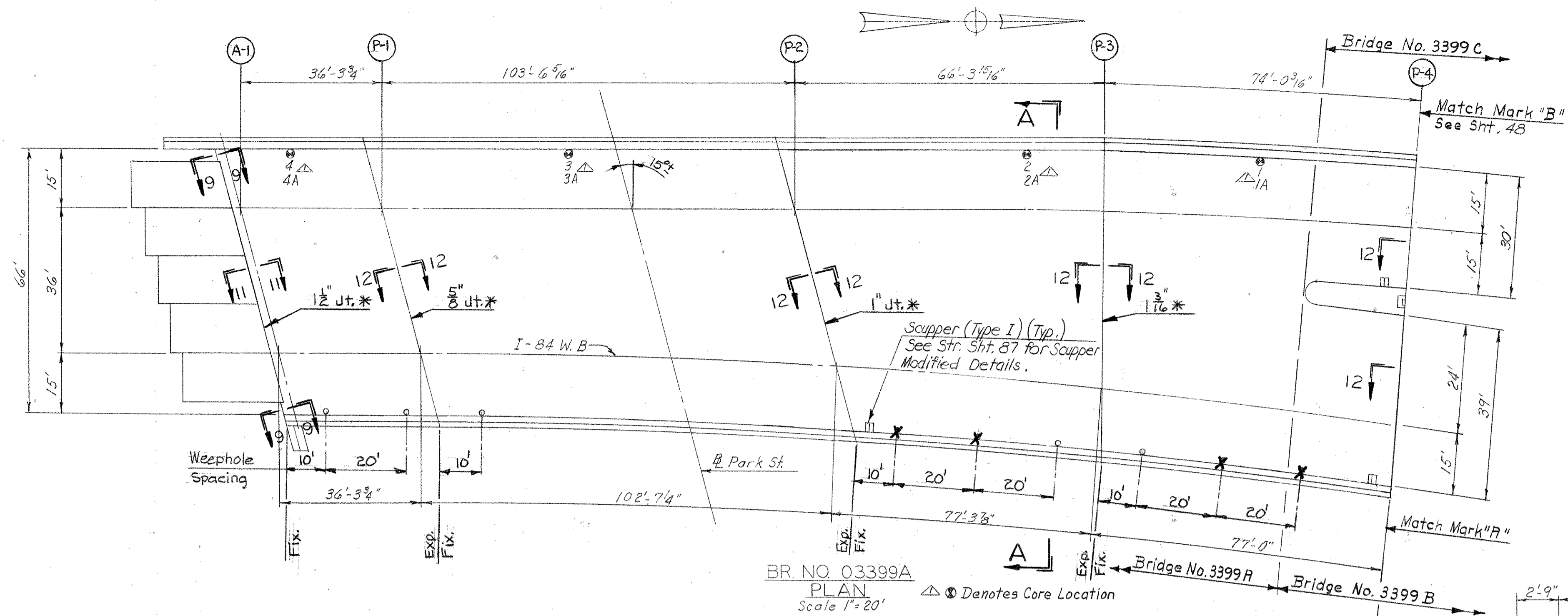

03399A

CORE NO.	△ CHLORIDE CONTENT	
	TOTAL % BY WT. LBS./CY.	WATER SOLUBLE % BY WT. LBS./CY.
1	0.022	0.862
1A	0.006	0.235
2	0.004	0.157
2A	0	0
3	0.019	0.745
3A	0.003	0.314
4	0.008	0.314
4A	0.001	0.039

See Note 4 Str. Sht. 6. Date 5/17/82

03399B

CORE NO.	△ CHLORIDE CONTENT	
	TOTAL % BY WT. LBS./CY.	WATER SOLUBLE % BY WT. LBS./CY.
1	0.025	0.980
1A	0.002	0.078
2	0.021	0.823
2A	0.002	0.078
3	0.006	0.235
3A	0.003	0.118
4	0.030	1.176
4A	0.002	0.078

See Note 4, Str. Sht. 6 Date 5/19/82

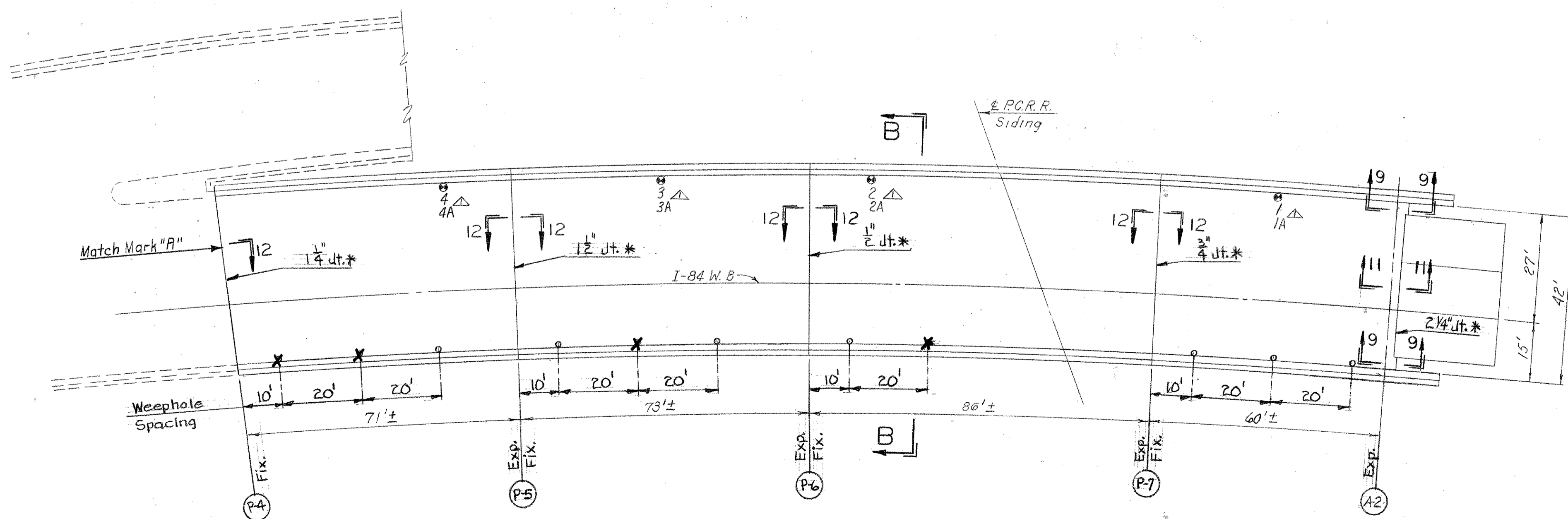
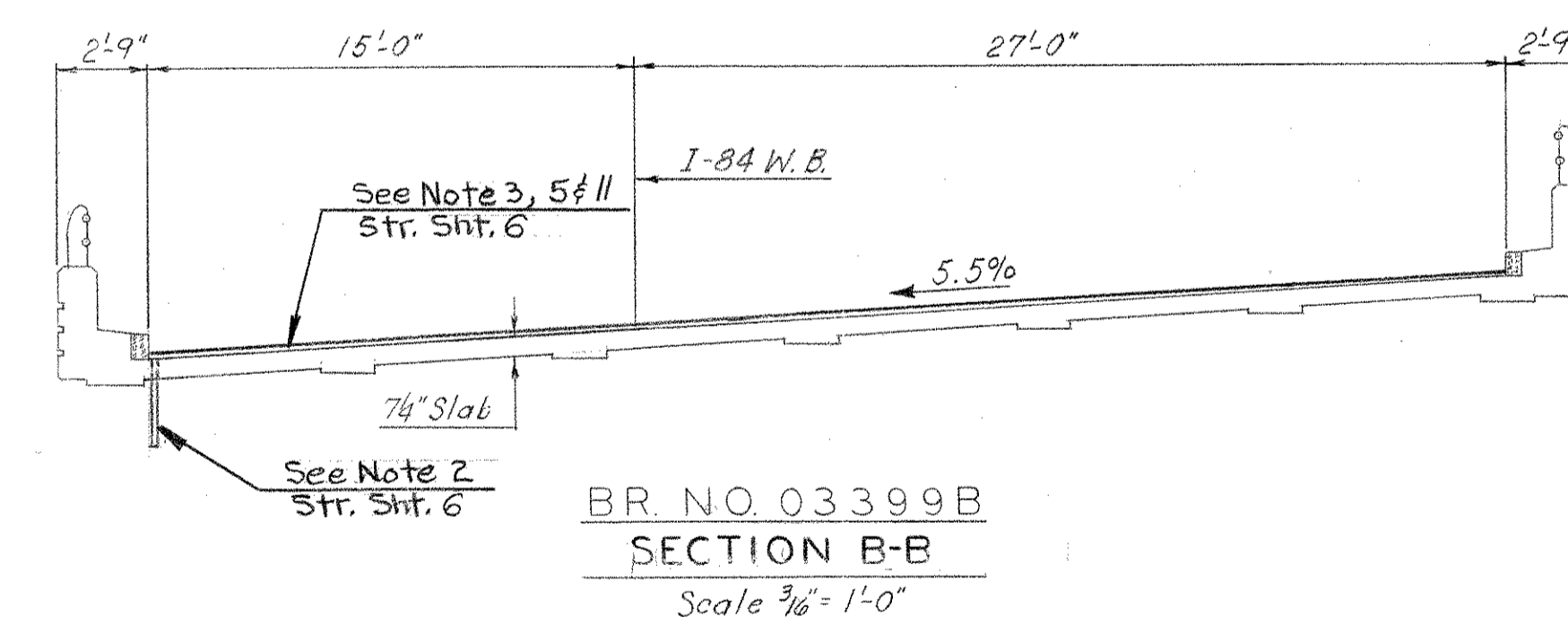
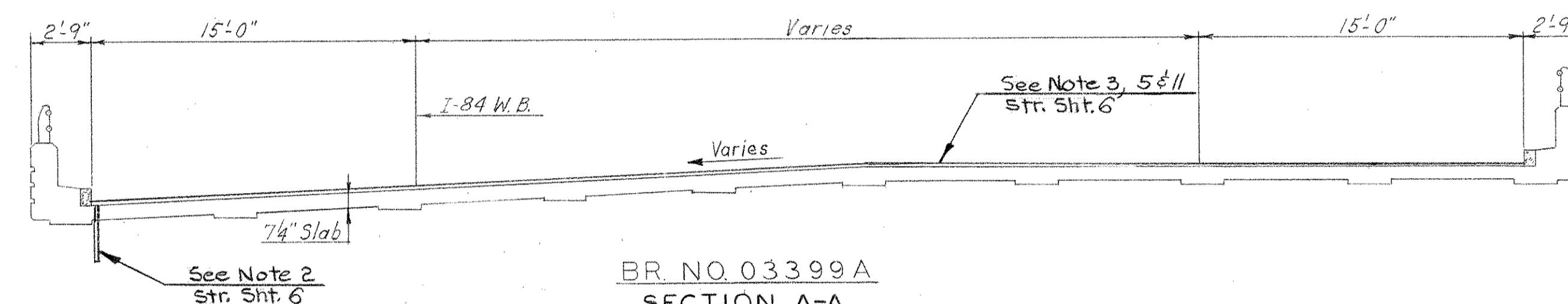

Note: For Section 9-9 see Str. Sht. 86.
For Sections 11-11 & 12-12 see Str. Sht. 82.

CONNECTICUT DEPARTMENT OF TRANSPORTATION		
SOUTHINGTON - HARTFORD		
INTERSTATE ROUTE 84		
61 STRUCTURES 24 LOCATIONS		
DECK REPAIRS		
I-84 W.B. OVER PARK ST. AND RAILROAD		
ENGINEER BRIDGE DESIGN UNIT		
DESIGNER J.P.L.	DRAFTER T.S.R.	CHECKER G.D.B.
NO. DATE	DESCRIPTION	APPROVED DATE
6-82	Chloride Samples added	<i>[Signature]</i> 3/17/82
REVISIONS		STRUCTURE NO. 131-145-3399A#3399B, 3399C
		BRIDGE LOG NO. 3399A&3399B 3399C
		STRUCTURE SHEET NO. 47.87

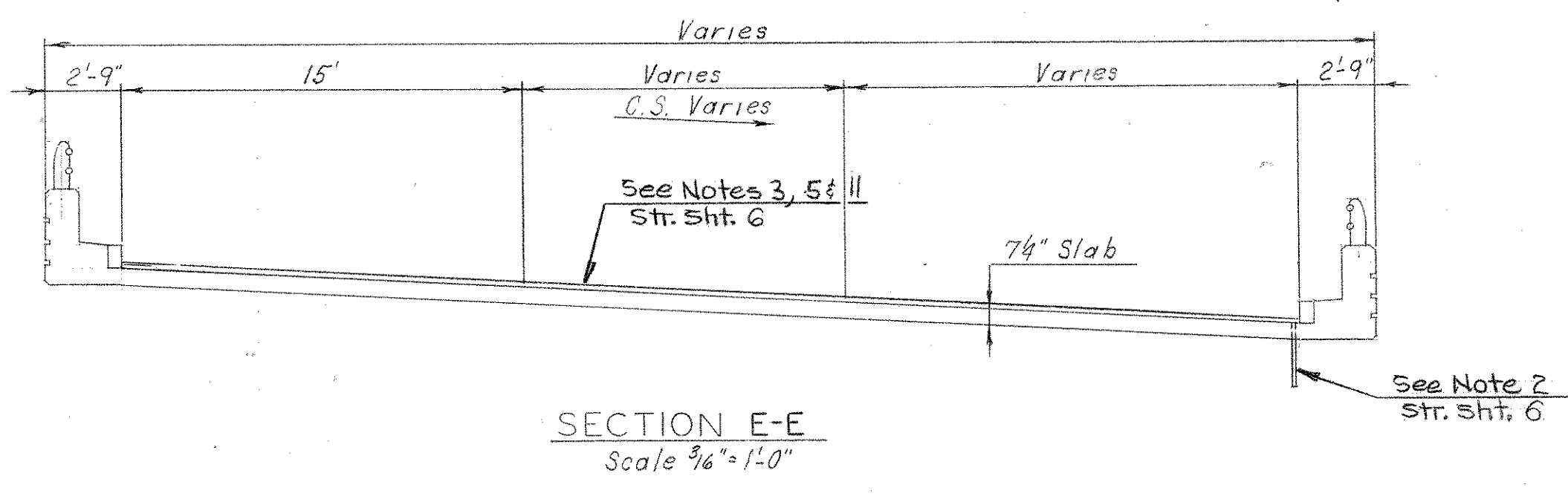
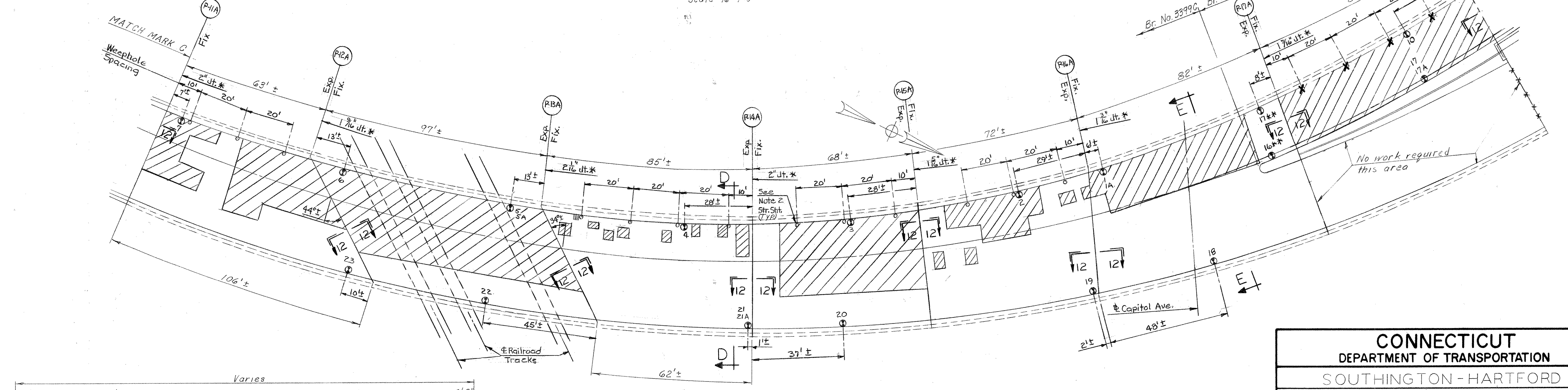
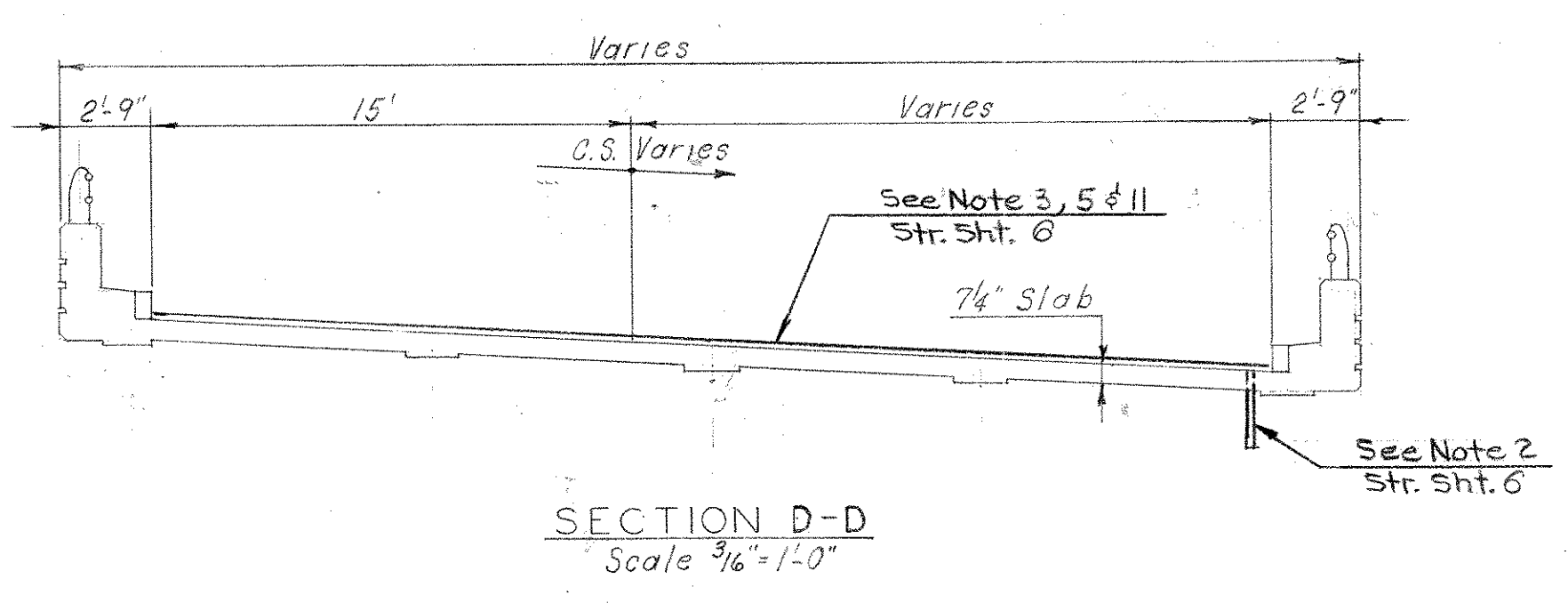
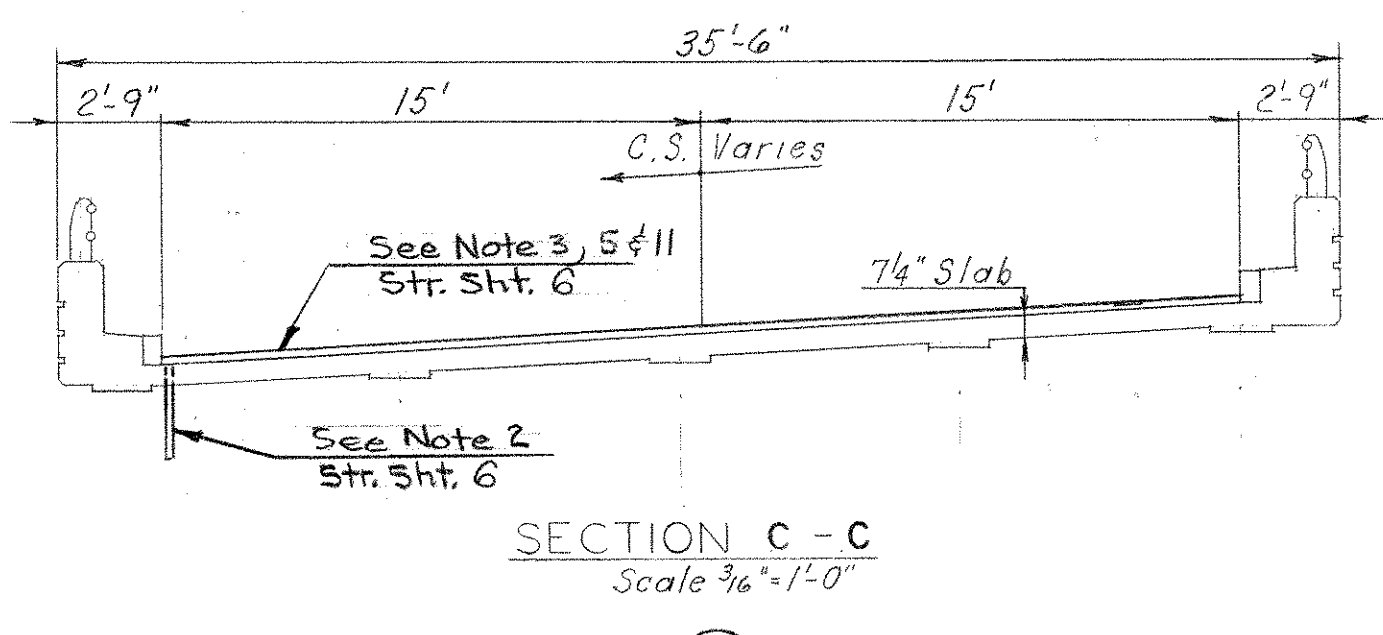
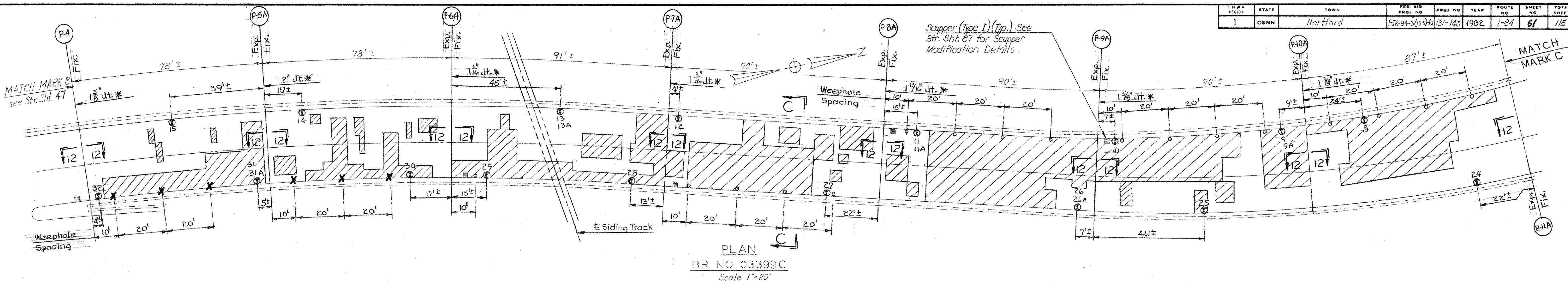

PLAN
BR. NO. 03399C
Scale 1"=20'

① Denotes Core Location
 * Joint Dimensions taken and Deck Survey done. 10-20-81 (Temp. 52°) (Measured @ E. Rdwy.)
 ** These Cores Tabulated on Bridge No. 3399C
 Note: For Section 12-12 see Str. Sht. 82.

THE INFORMATION, INCLUDING ESTIMATED QUANTITIES OF WORK SHOWN ON THESE SHEETS IS BASED ON LIMITED INVESTIGATIONS BY THE STATE AND IS IN NO WAY WARRANTED TO INDICATE THE TRUE CONDITIONS OR ACTUAL QUANTITIES OR DISTRIBUTION OF QUANTITIES OF WORK WHICH WILL BE REQUIRED.

CONNECTICUT			
DEPARTMENT OF TRANSPORTATION			
SOUTHINGTON - HARTFORD			
INTERSTATE ROUTE 84			
59 STRUCTURES			
DECK REPAIRS			
SISSON AVE ON RAMP TO W. B I-84			
ENGINEER BRIDGE DESIGN UNIT			
DESIGNER J. P. L.	DRAFTER T. S. R.	CHECKER G. D. B.	
NO. DATE	DESCRIPTION	APPROVED <i>[Signature]</i>	DATE 3/17/82
REVISIONS		STRUCTURE NO. 131-145-3399C+3399D	BRIDGE LOG NO. 3399C+3399D STRUCTURE SHEET NO. 48 of 87

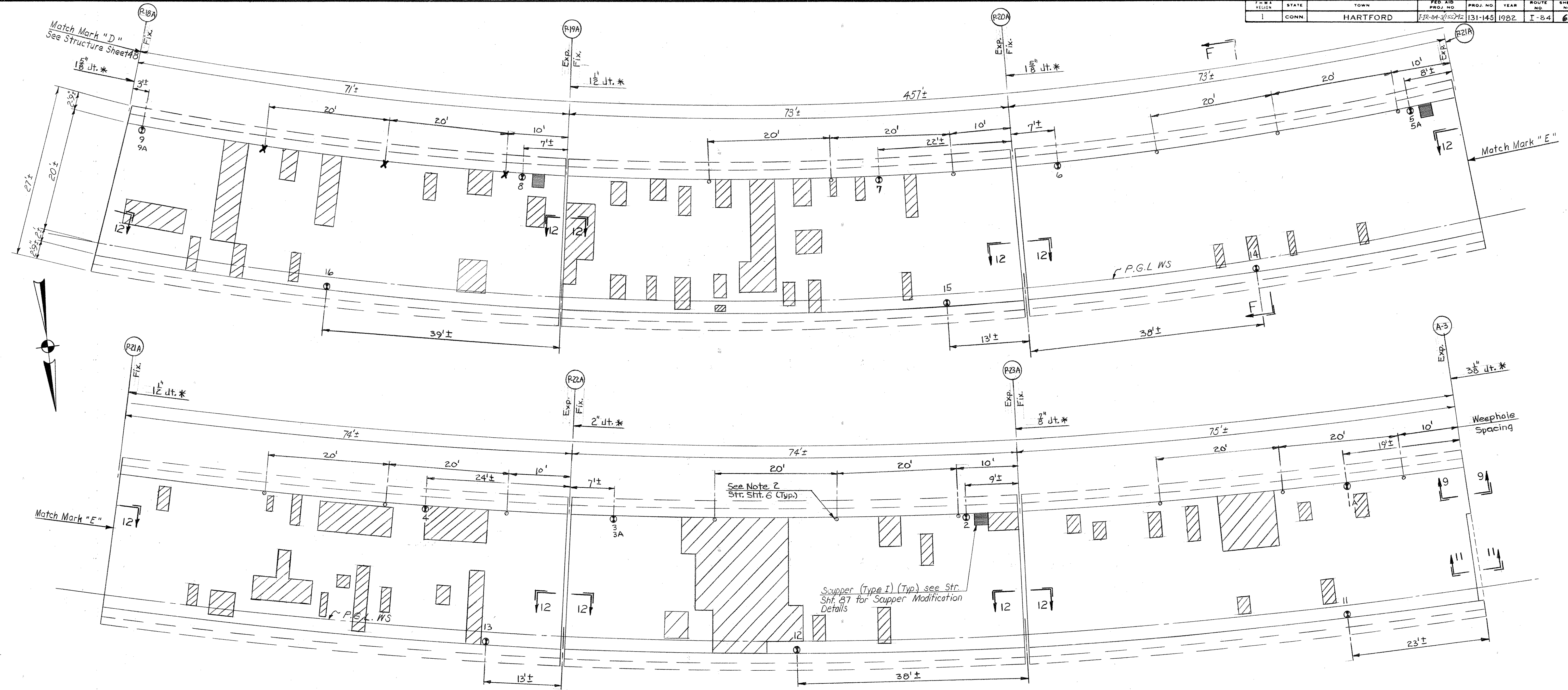

⊙ Denotes Core Location
 * Joint Dimensions taken and deck condition survey done 10-20-81 (Temp. 52°) (Measured @ E. Rdwy.)

ON RAMP FROM SISSON AVE. TO I-84 W. B.
 SCALE 1/8" = 1'-0"

Note: For Section 9-9 see Str. Sht. 86.
 For Sections 11-11 & 12-12, see Str. Sht. 82.

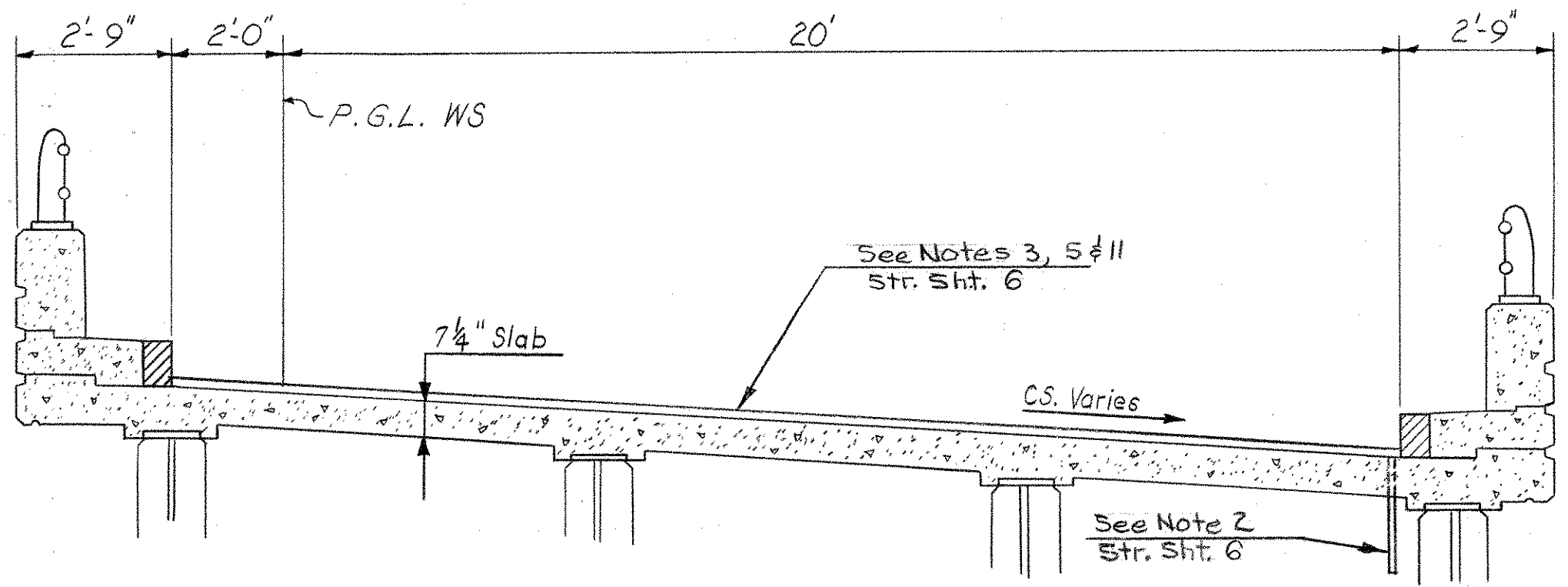

SECTION F-F
 SCALE 3/8" = 1'-0"

THE INFORMATION, INCLUDING ESTIMATED QUANTITIES OF WORK SHOWN ON THESE SHEETS IS BASED ON LIMITED INVESTIGATIONS BY THE STATE AND IS IN NO WAY WARRANTED TO INDICATE THE TRUE CONDITIONS OR ACTUAL QUANTITIES OR DISTRIBUTION OF QUANTITIES OF WORK WHICH WILL BE REQUIRED.

CONNECTICUT DEPARTMENT OF TRANSPORTATION		
SOUTHINGTON - HARTFORD		
INTERSTATE ROUTE 84		
59 STRUCTURES		
DECK REPAIRS		
SISSON AVE ON RAMP TO WB. I-84		
ENGINEER BRIDGE DESIGN UNIT		
DESIGNER J.P.L.	DRAFTER J.J.C.	CHECKER G.D.B.
APPROVED <i>[Signature]</i>	DATE 3/17/82	
NO. DATE	DESCRIPTION	REVISIONS
STRUCTURE NO. 131-145-3399D		BRIDGE LOG NO. 3399 D
		STRUCTURE SHEET NO. 49 of 87

F.H.W. REGION	STATE	TOWN	FED. AID PROJ. NO.	PROJ. NO.	YEAR	ROUTE NO.	SHEET NO.	TOTAL SHEETS
1	CONN.	Southington - Hartford	F1R-81-3(55)42	31-145	1982	I-84	63	115

BR. NO. 3399 C

CORE NO.	CHLORIDE CONTENT			
	TOTAL		WATER SOLUBLE	
	% BY WT.	LBS./C.Y.	% BY WT.	LBS./C.Y.
(See Note 4 Str. Sht. 12-1-81)				
1	0.151	5.919		
1A	0.020	0.784		
2	0.054	2.117		
3	0.048	1.882		
4	0.102	3.998		
5	0.140	5.488		
5A	0.015	0.588		
6	0.041	1.607		
7	0.080	3.136		
8	0.069	2.705		
9	0.257	10.074	0.243	9.526
9A	0.029	1.137		
10	0.173	6.782		
11	0.180	7.056	0.166	6.507
11A	0.072	2.822		
12	0.094	3.685		
13	0.141	5.527		
13A	0.102	3.998		
14	0.061	2.391		
15	0.077	3.018		
16	0.043	1.686		
17	0.005	0.196		
18	0.006	0.235		
19	0.006	0.235		
20	0.006	0.235		
21	0.029	1.137		
21A	0.004	0.157		
22	0.026	1.019		
23	0.047	1.842		
24	0.029	1.137		
25	0.061	2.391		
26	0.131	5.135		
26A	0.018	0.706		
27	0.017	0.666		
28	0.181	7.095		
29	0.078	3.058		
30	0.149	5.841		
31	0.312	12.230	0.290	11.368
31A	0.125	4.900		
32	0.101	3.959		

BR. NO. 3399 D

CORE NO.	CHLORIDE CONTENT			
	TOTAL		WATER SOLUBLE	
	% BY WT.	LBS./C.Y.	% BY WT.	LBS./C.Y.
(See Note 4 Str. Sht. 11-20-81)				
1	0.159	6.233		
1A	0.050	1.960		
2	0.046	1.803		
3	0.223	8.742	0.212	8.310
3A	0.018	0.706		
4	0.137	5.370		
5	0.167	6.546	0.160	6.272
5A	0.092	3.600		
6	0.184	7.213		
7	0.084	3.293		
8	0.105	4.116		
9	0.245	9.604	0.233	9.134
9A	0.022	0.862		
10	0.157	6.154		
11	0.052	2.038		
12	0.061	2.391		
13	0.084	3.293		
14	0.007	0.274		
15	0.041	1.607		
16	0.049	1.921		
17	0.087	3.410		
17A	0.009	0.353		

STATE OF CONNECTICUT
DEPARTMENT OF TRANSPORTATION
 SOUTHINGTON - HARTFORD
 INTERSTATE ROUTE 84
 59 STRUCTURES
 DECK REPAIRS
 BR. NO. 3399 C & D - CHLORIDE TABLES

NO.	DATE	DESCRIPTION

THE INFORMATION, INCLUDING ESTIMATED QUANTITIES OF WORK SHOWN ON THESE SHEETS IS BASED ON LIMITED INVESTIGATIONS BY THE STATE AND IS IN NO WAY WARRANTED TO INDICATE THE TRUE CONDITIONS OR ACTUAL QUANTITIES OR DISTRIBUTION OF QUANTITIES OF WORK WHICH WILL BE REQUIRED.

ENGINEER BRIDGE DESIGN UNIT		
DESIGNER G. D. B.	DRAFTER F. T. R.	CHECKER G. D. B.
APPROVED <i>W. A. Johnson</i>	DATE 3/17/82	
STRUCTURE NO. 131-145-3399C-3399D	BRIDGE NO. 3399C-3399D	STRUCTURE SHEET NO. 50 of 87

F.H.W.A. REGION	STATE	TOWN	FED. AID PROJ. NO.	PROJ. NO.	YEAR	ROUTE NO.	SHEET NO.	TOTAL SHEETS
1	CONN.	Hartford	I-84-3(53)A	131-145	1982	I-84	64	115

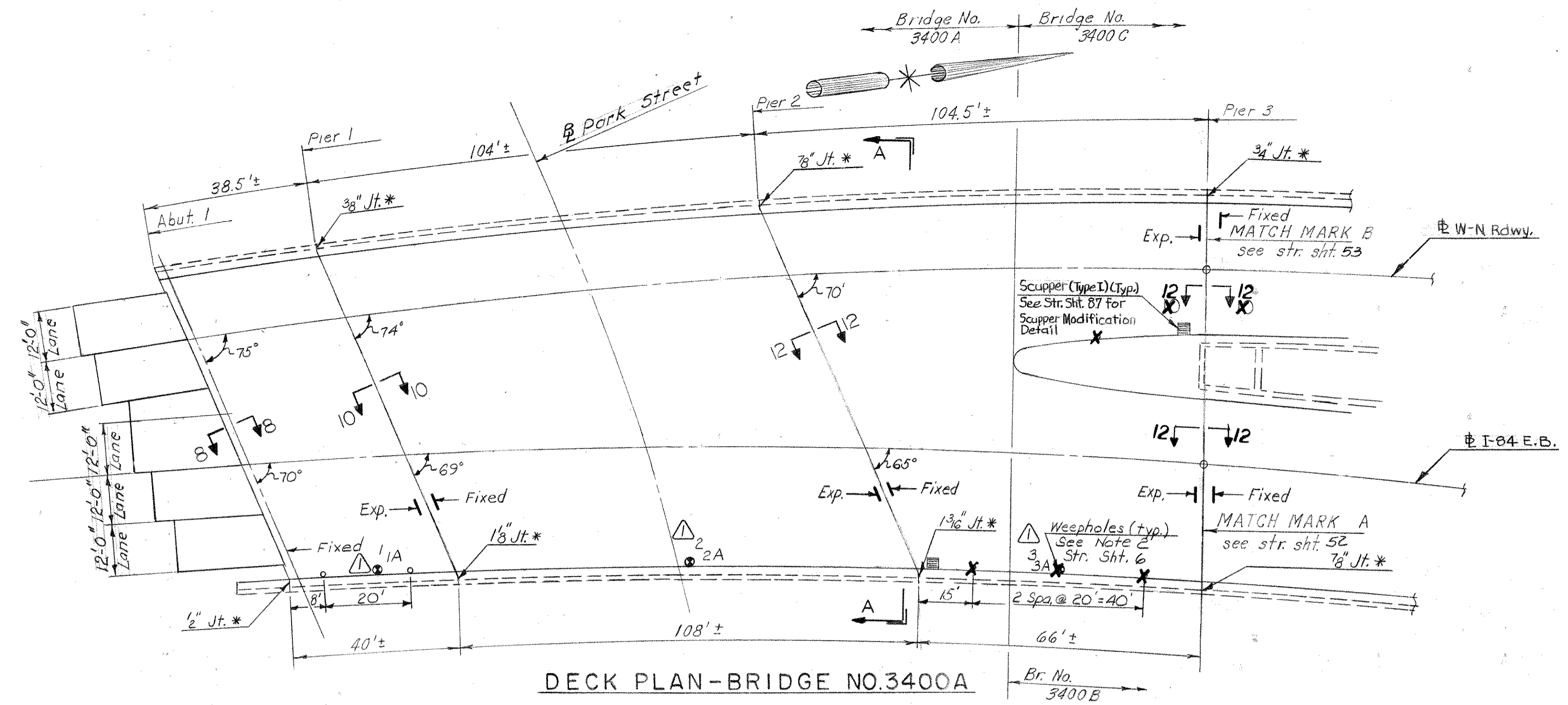

DECK PLAN-BRIDGE NO.3400A
 I-84 BRIDGE NO.2 S.E. SOUTH ABUT. TO PIER S.E. 3.
 * Jt. Dimensions Taken On 7-16-81

CORE NO.	BR. NO. 03400A			
	CHLORIDE TOTAL		CONTENT WATER SOLUBLE	
	% BY WT.	LBS./C.Y.	% BY WT.	LBS./C.Y.
1	0.045	1.764	0.038	1.490
1A	0.026	1.019		
2	0.055	2.156	0.050	1.960
2A	0.008	0.314		
3	0.074	2.901	0.063	2.470
3A	0.056	2.195		

(See Note 4 Str. Sht. 6 Date 4/27/82)

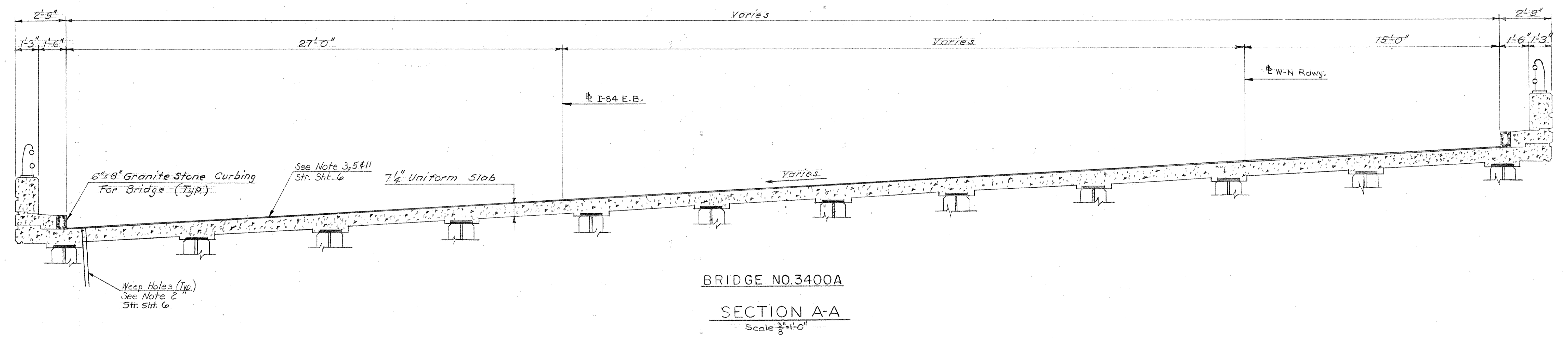

BRIDGE NO.3400A
 SECTION A-A
 Scale 3/8"=1'-0"

Note: For Sections 8-8 & 10-10 see Str. Sht. 86
 For Section 12-12 see Str. Sht. 82

△ • Denotes Core Locations

CONNECTICUT			
DEPARTMENT OF TRANSPORTATION			
SOUTHINGTON - HARTFORD			
INTERSTATE ROUTE 84			
59 STRUCTURES			
DECK REPAIRS			
I-84 E.B. OVER PARK STREET.			
ENGINEER BRIDGE DESIGN UNIT			
DESIGNER J. P. L.		DRAFTER G. O. K.	CHECKER G. D. B.
NO.	DATE	DESCRIPTION	APPROVED
			<i>[Signature]</i>
REVISIONS		STRUCTURE NO. 131-145-3400A-B-C	BRIDGE LOG NO. 3400A-B-C
		STRUCTURE SHEET NO. 51	OF 87

THE INFORMATION, INCLUDING ESTIMATED QUANTITIES OF WORK SHOWN ON THESE SHEETS IS BASED ON LIMITED INVESTIGATIONS BY THE STATE AND IS IN NO WAY WARRANTED TO INDICATE THE TRUE CONDITIONS OR ACTUAL QUANTITIES OR DISTRIBUTION OF QUANTITIES OF WORK WHICH WILL BE REQUIRED.

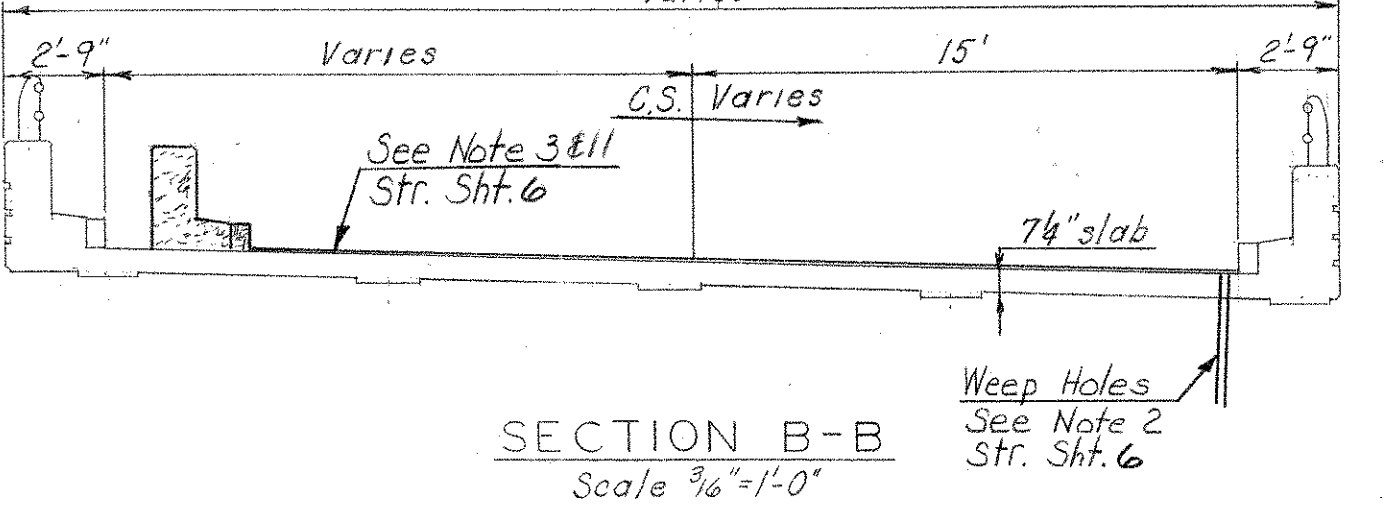
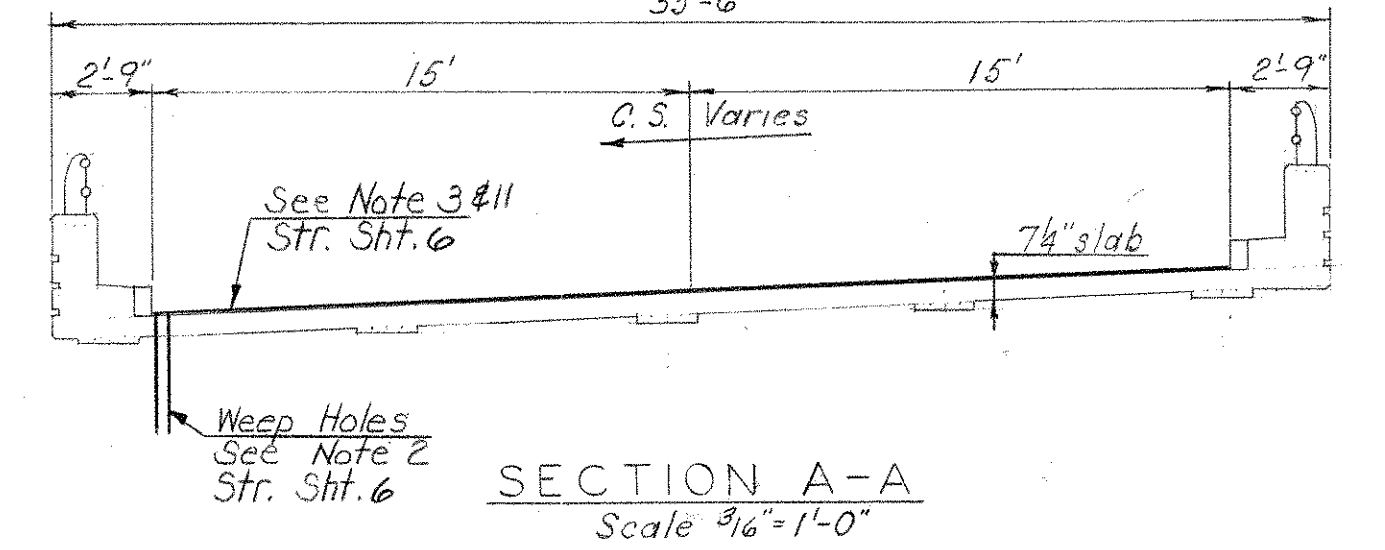
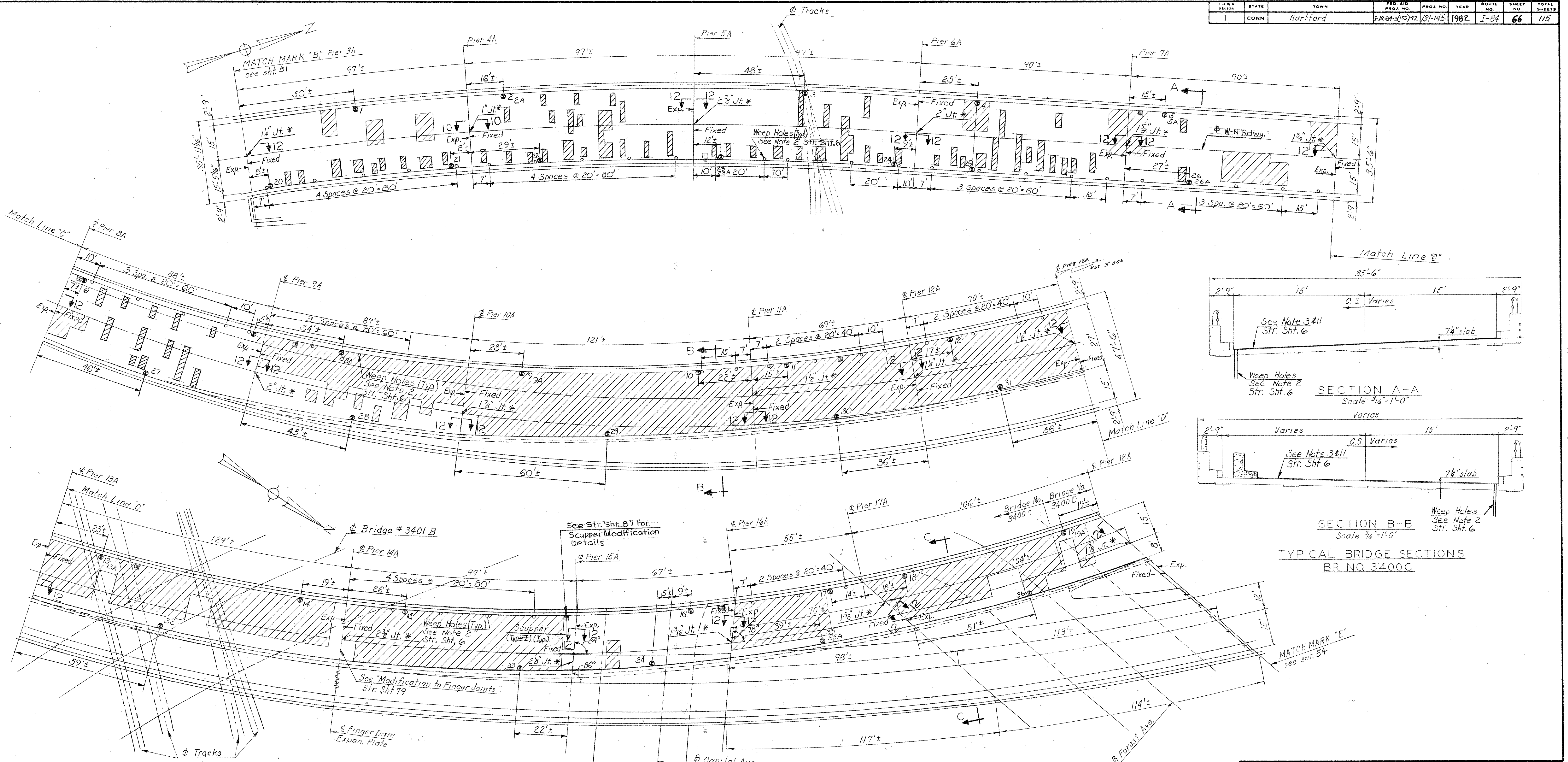

TYPICAL BRIDGE SECTIONS
BR NO 3400C

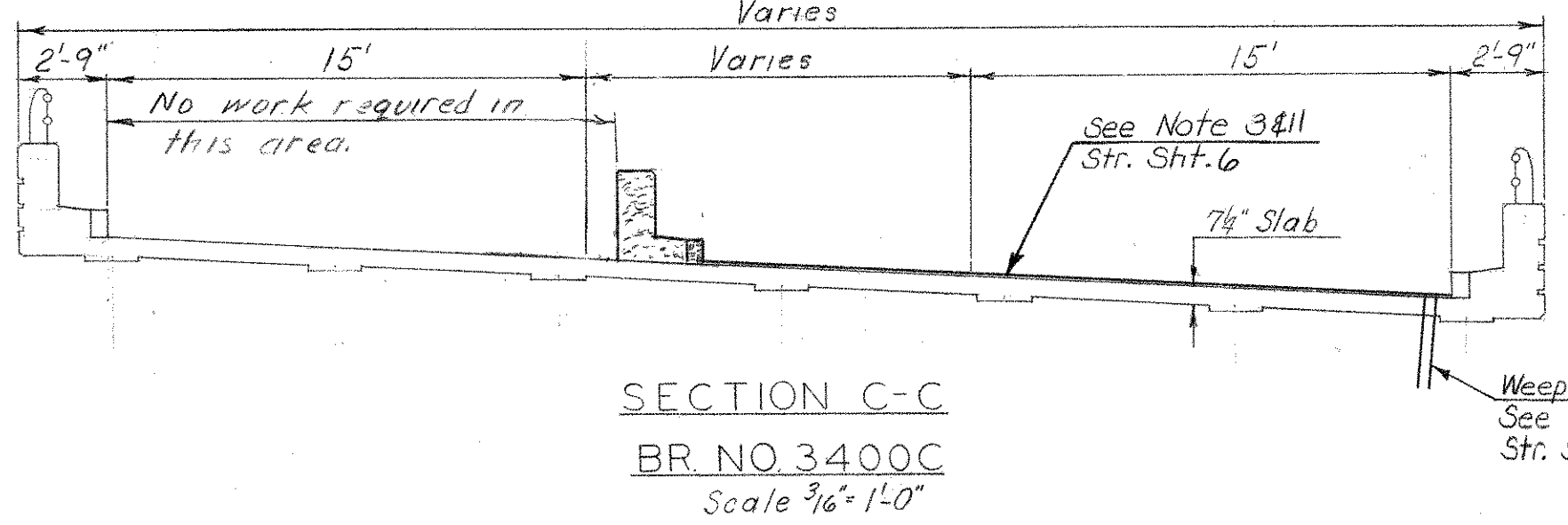

BR NO 3400C
PLAN
Scale 1" = 20'

● Denotes Core Location
* Jt. Dimensions Taken At A Temperature Of 48°
Note: For Section 10-10 see Str. Sht. 86
For Section 12-12 see Str. Sht. 82

CONNECTICUT			
DEPARTMENT OF TRANSPORTATION			
SOUTHINGTON - HARTFORD			
INTERSTATE ROUTE 84			
59 STRUCTURES			
DECK REPAIRS			
E.B OFF RAMP TO SISSON AVE.			
ENGINEER BRIDGE DESIGN UNIT			
DESIGNER	J. P. L.	DRAFTER	T. S. R.
CHECKER	G. D. B.	DATE	3/17/82
NO. DATE		DESCRIPTION	
REVISIONS		STRUCTURE NO. 131-145-3400C+D	
		BRIDGE LOG NO.	3400C&D
		STRUCTURE SHEET NO.	53 of 87

THE INFORMATION, INCLUDING ESTIMATED QUANTITIES OF WORK SHOWN ON THESE SHEETS IS BASED ON LIMITED INVESTIGATIONS BY THE STATE AND IS IN NO WAY WARRANTED TO INDICATE THE TRUE CONDITIONS OR ACTUAL QUANTITIES OR DISTRIBUTION OF QUANTITIES OF WORK WHICH WILL BE REQUIRED.

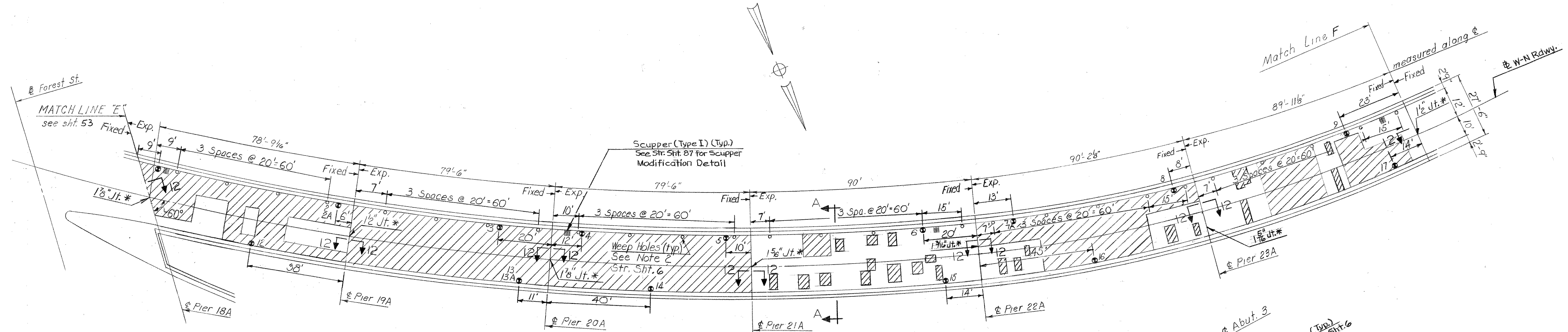

PLAN
BR. NO. 03400D
Scale 1"=20'

• Denotes Core Location
* Jt. Dimensions Taken At A Temp. Of 48°

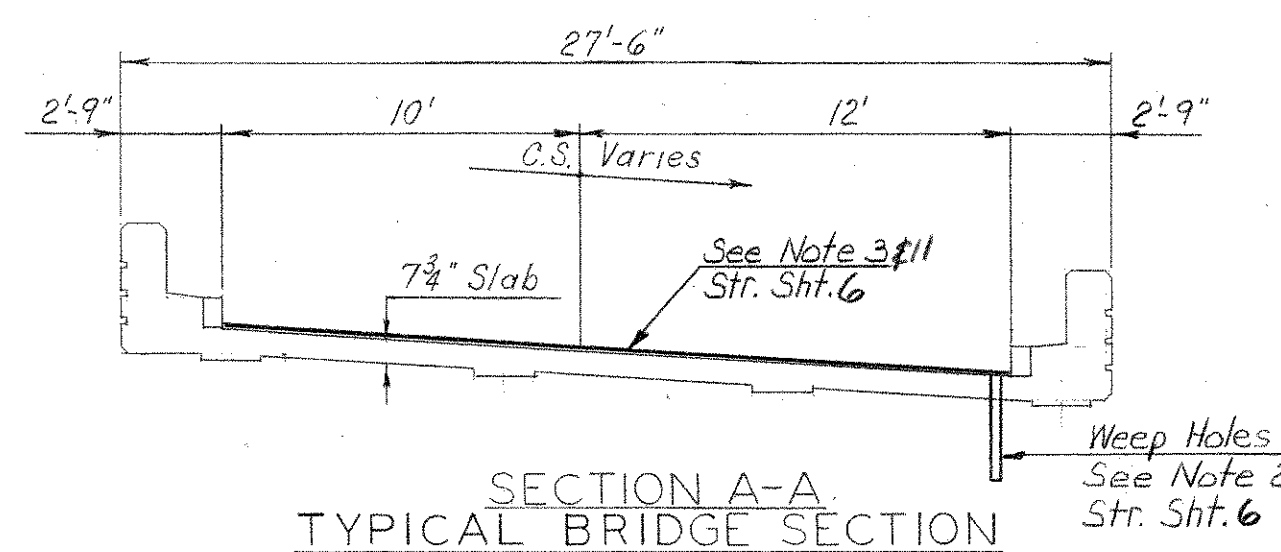

SECTION A-A
TYPICAL BRIDGE SECTION
BR. NO. 03400D
Scale 3/8"=1'-0"

CORE NO.	CHLORIDE TOTAL		CONTENT WATER SOLUBLE	
	% BY WT.	LBS./CY.	% BY WT.	LBS./CY.
(See Note 4 Str. Sht. 6 Date 12/14/81)				
1	0.151	5.919		
2	0.177	6.938		
2A	0.110	4.312		
3	0.126	4.939		
4	0.116	4.547		
5	0.048	1.882		
6	0.007	0.274		
7	0.244	9.565	0.209	8.193
7A	0.086	3.371		
8	0.041	1.607		
9	0.062	2.430		
10	0.204	7.997	0.178	6.978
10A	0.028	1.098		
11	0.179	7.017	0.159	6.233
12	0.057	2.234		
13	0.084	3.293		
13A	0.008	0.314		
14	0.014	0.549		
15	0.005	0.196		
16	0.033	1.294		
17	0.025	0.980		
18	0.041	1.607		

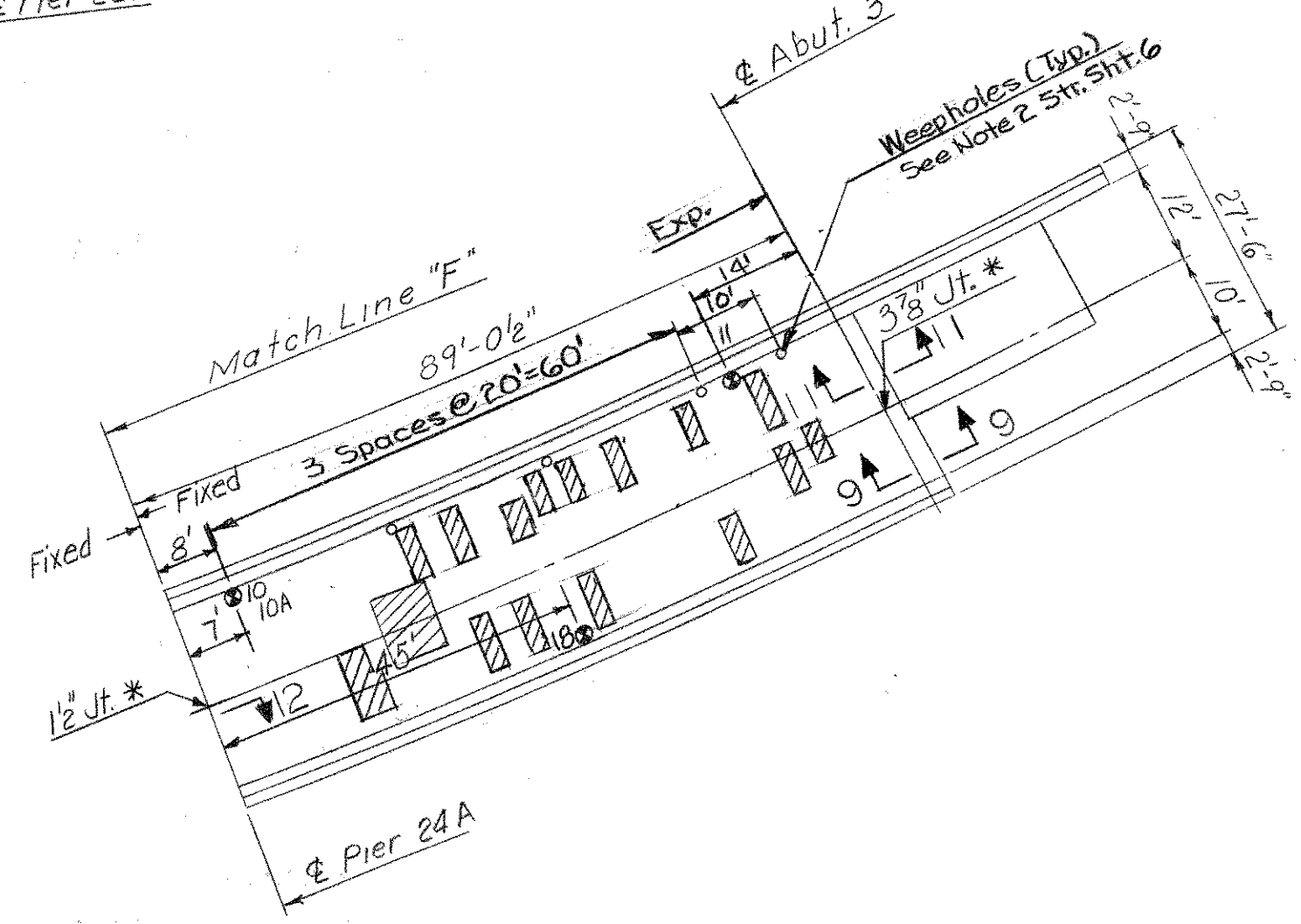

Note: For Section 9-9 see Str. Sht. 86
For Sections 11-11 & 12-12 see Str. Sht. 82

CONNECTICUT	
DEPARTMENT OF TRANSPORTATION	
SOUTHINGTON - HARTFORD	
INTERSTATE ROUTE 84	
59 STRUCTURES	
DECK REPAIRS	
OFF RAMP FROM I-84EB TO SISSON AVE OVER FOREST ST	
ENGINEER BRIDGE DESIGN UNIT	
DESIGNER J. P. L.	DRAFTER T. S. R.
CHECKER G. D. B.	
NO. DATE	DESCRIPTION
APPROVED <i>[Signature]</i>	DATE 3/17/82
REVISIONS	STRUCTURE NO. 131-145-3400D
	BRIDGE LOG NO. 3400D
	STRUCTURE SHEET NO. 54 of 87

THE INFORMATION, INCLUDING ESTIMATED QUANTITIES OF WORK SHOWN ON THESE SHEETS IS BASED ON LIMITED INVESTIGATIONS BY THE STATE AND IS IN NO WAY WARRANTED TO INDICATE THE TRUE CONDITIONS OR ACTUAL QUANTITIES OR DISTRIBUTION OF QUANTITIES OF WORK WHICH WILL BE REQUIRED.

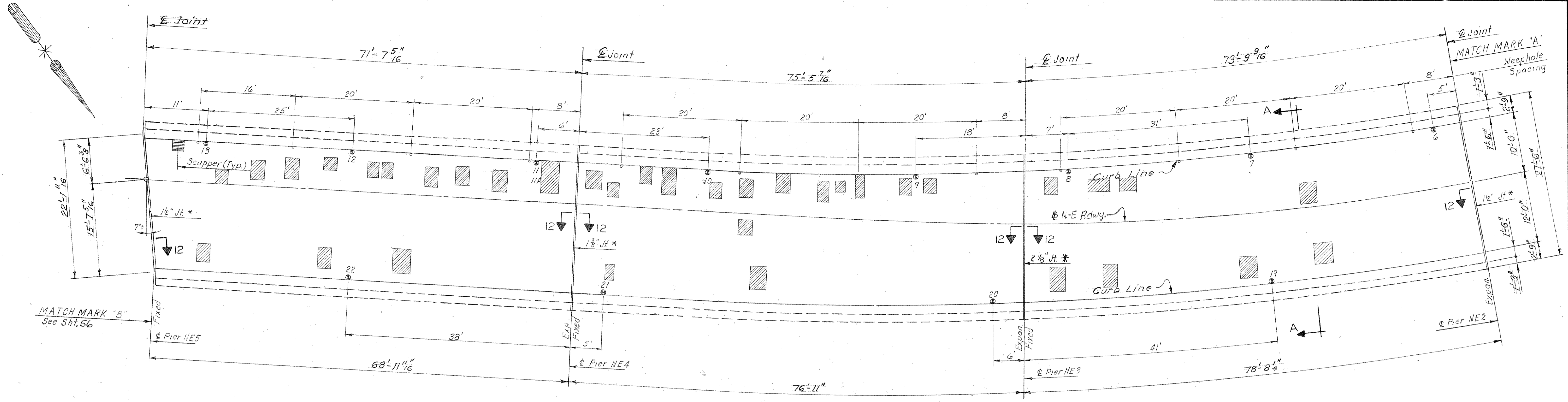

• Denotes Core Locations, see Str. Sht. 58 & 59 for chloride content of cores.
 * Jt. dimensions taken at 58° Deck Condition Survey done 9-21-81 For Dr. Nos. 3401 A & B

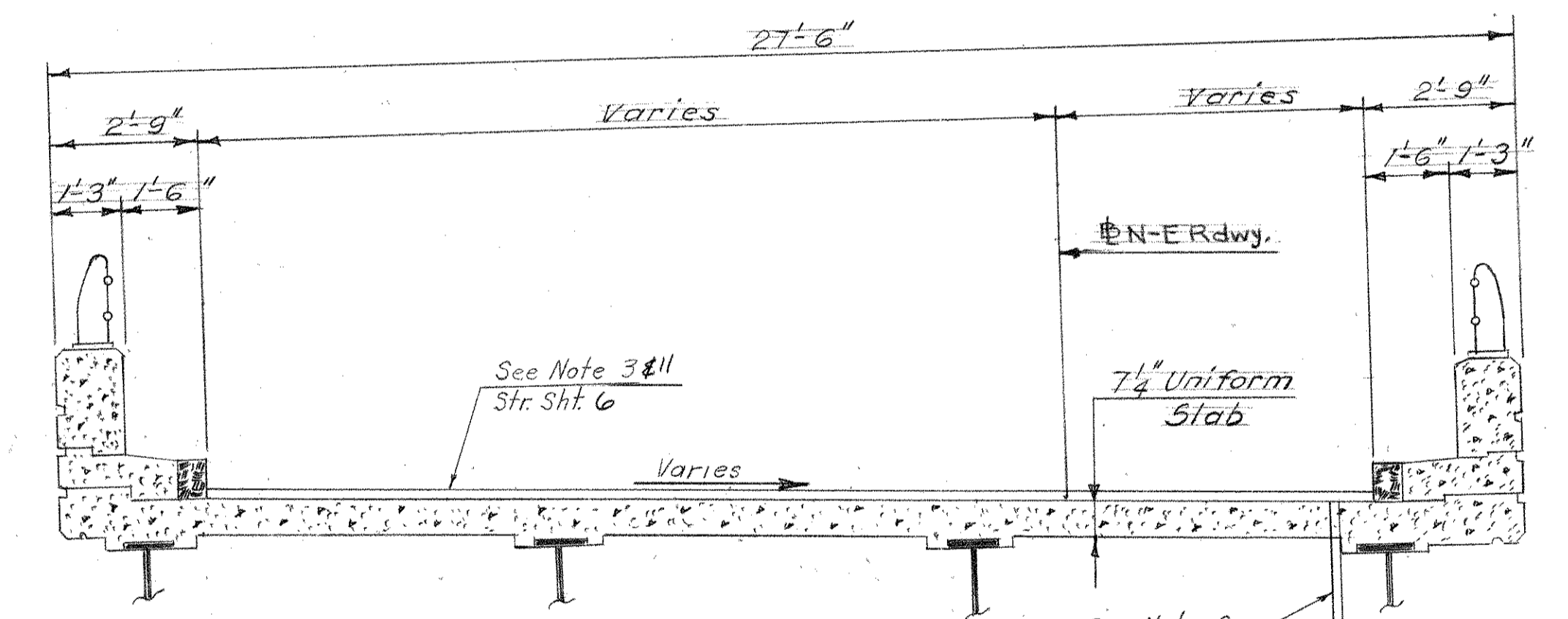
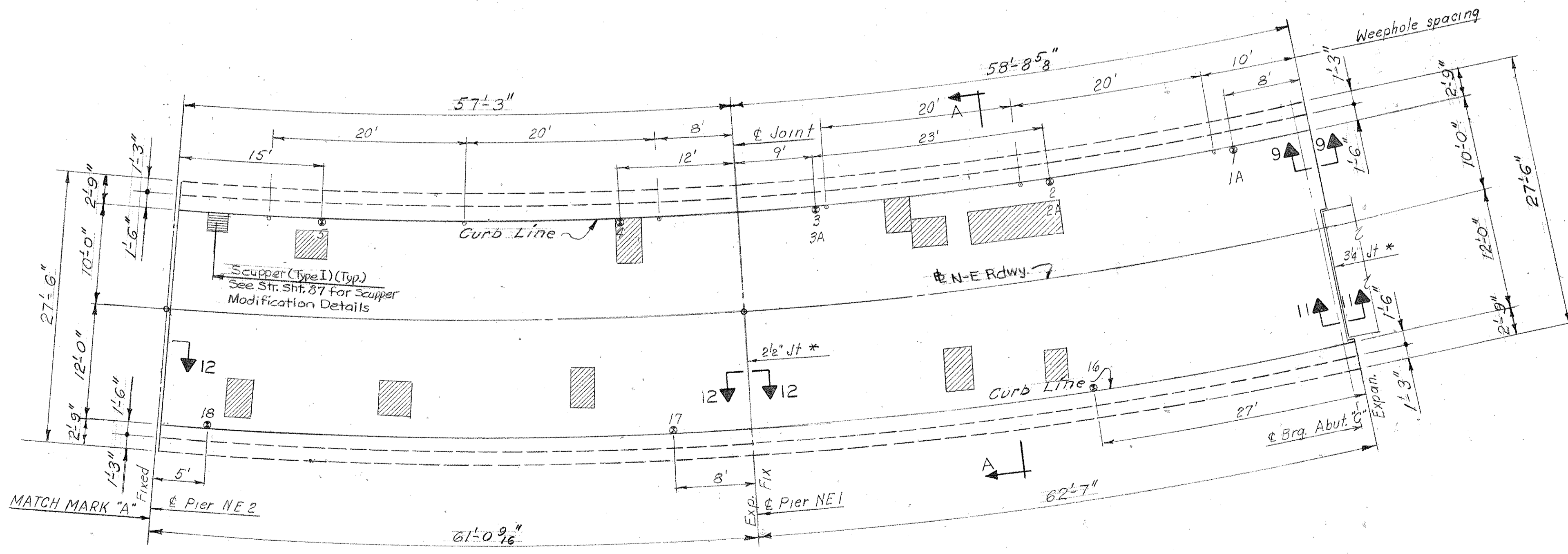

BRIDGE NO. 3401
TYPICAL BRIDGE SECTION-SECTION A-A
Scale 3/8" = 1'-0"

Note: For Section 9-9 see Str. Sht. 86
 For Sections 11-11 & 12-12 see Str. Sht. 82

CONNECTICUT
 DEPARTMENT OF TRANSPORTATION
 SOUTHTON - HARTFORD
 INTERSTATE ROUTE 84
 59 STRUCTURES
 DECK REPAIRS
 ON RAMP TO E.B I-84 FROM SISSON AVE.

ENGINEER BRIDGE DESIGN UNIT		DESIGNER J.P.L.		DRAFTER G.O.K.		CHECKER G.D.B.	
APPROVED <i>[Signature]</i>		DATE 3/10/82		BRIDGE LOG NO. 3401A		STRUCTURE SHEET NO. 55 OF 87	
NO. DATE		DESCRIPTION		REVISIONS		STRUCTURE NO. 131-145-3401A	

THE INFORMATION, INCLUDING ESTIMATED QUANTITIES OF WORK SHOWN ON THESE SHEETS IS BASED ON LIMITED INVESTIGATIONS BY THE STATE AND IS IN NO WAY WARRANTED TO INDICATE THE TRUE CONDITIONS OR ACTUAL QUANTITIES OR DISTRIBUTION OF QUANTITIES OF WORK WHICH WILL BE REQUIRED.

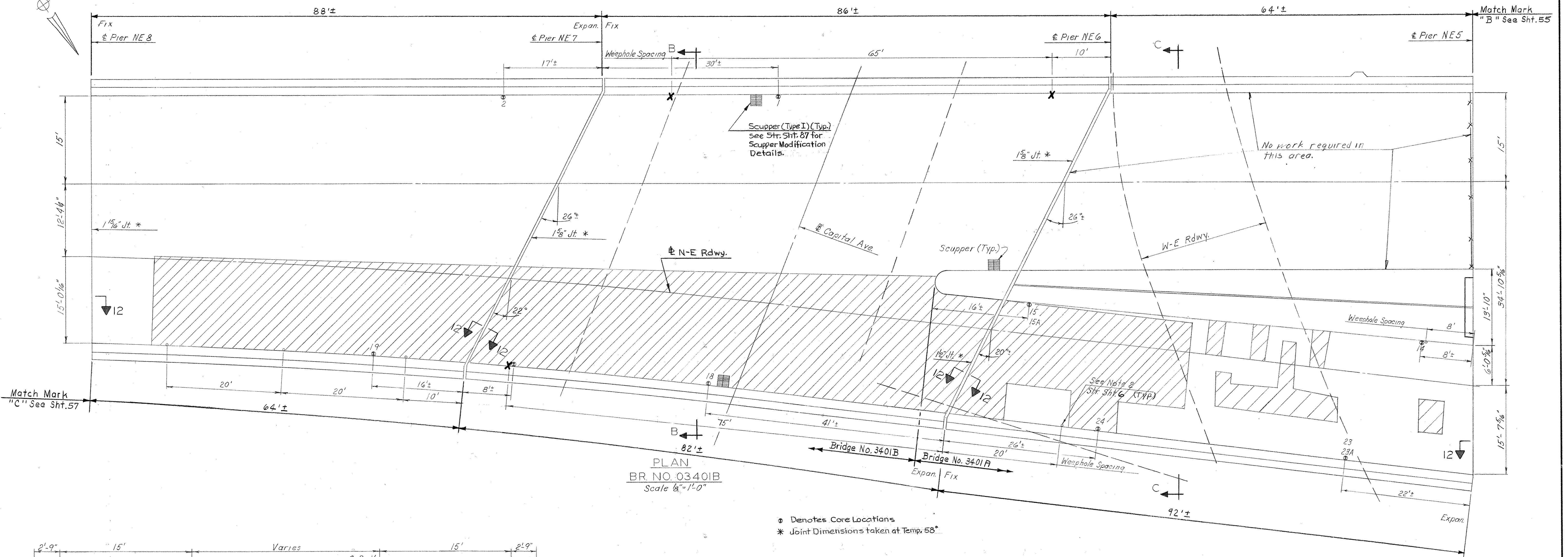

PLAN
BR. NO. 03401B
Scale 1/8" = 1'-0"

⊙ Denotes Core Locations
* Joint Dimensions taken at Temp. 58°

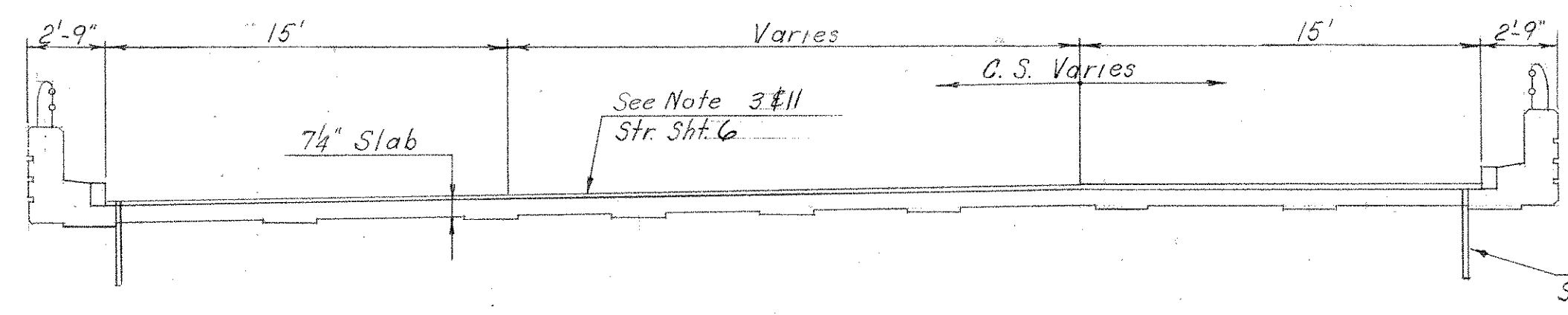

SECTION B-B
Scale 3/16" = 1'-0"

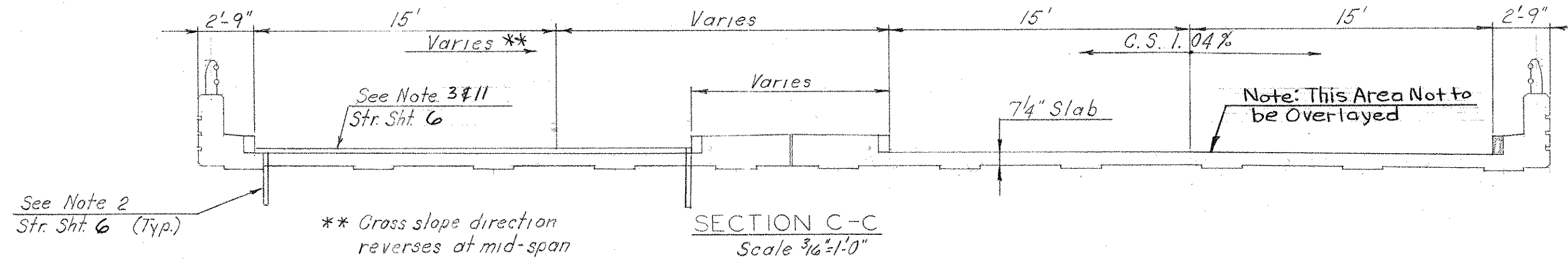

SECTION C-C
Scale 3/16" = 1'-0"

Note: For Section 12-12 see Str. Sht. 82

CONNECTICUT
DEPARTMENT OF TRANSPORTATION
SOUTHINGTON - HARTFORD
INTERSTATE ROUTE 84
59 STRUCTURES
DECK REPAIRS
ON RAMP TO E. B. I-84 FROM SISSON AVE.

ENGINEER BRIDGE DESIGN UNIT		DESIGNER J.P.L.		DRAFTER T.S.R.		CHECKER G.D.B.	
APPROVED <i>[Signature]</i>		DATE 3/17/82		BRIDGE LOG NO. 3401 A&B		STRUCTURE SHEET NO. 56 OF 87	
NO. DATE		DESCRIPTION		REVISIONS			

THE INFORMATION, INCLUDING ESTIMATED QUANTITIES OF WORK SHOWN ON THESE SHEETS IS BASED ON LIMITED INVESTIGATIONS BY THE STATE AND IS IN NO WAY WARRANTED TO INDICATE THE TRUE CONDITIONS OR ACTUAL QUANTITIES OR DISTRIBUTION OF QUANTITIES OF WORK WHICH WILL BE REQUIRED.

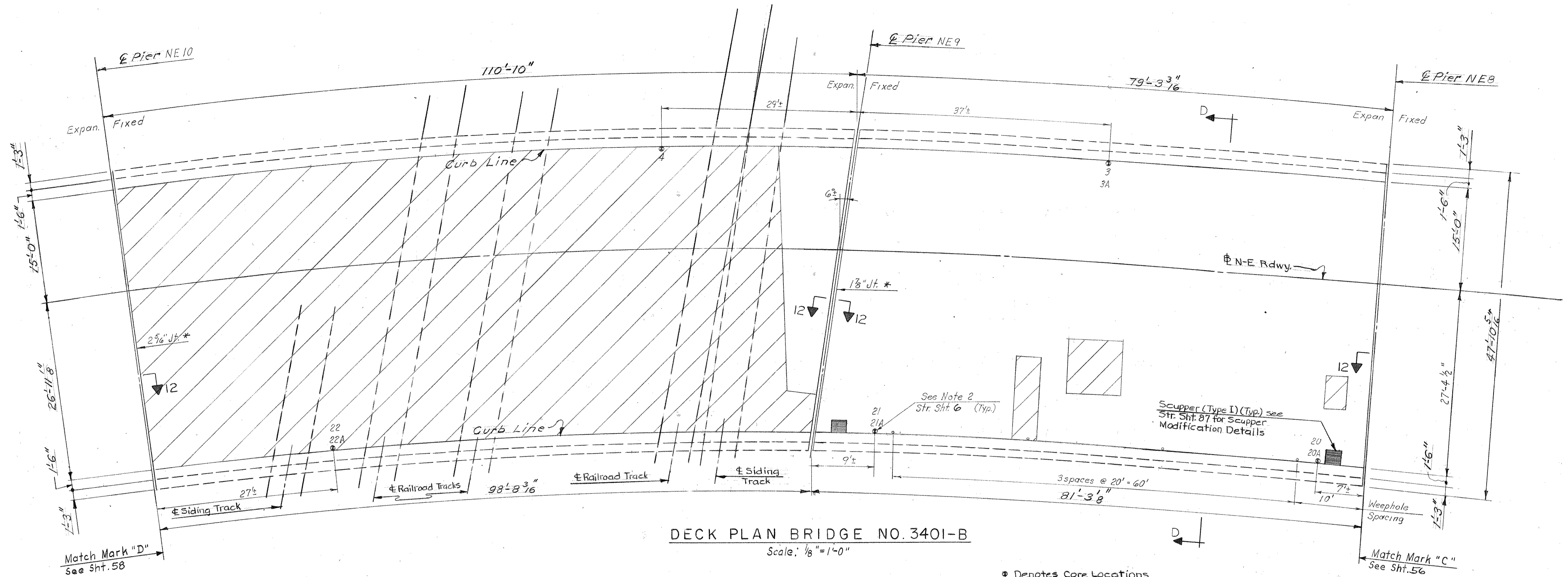
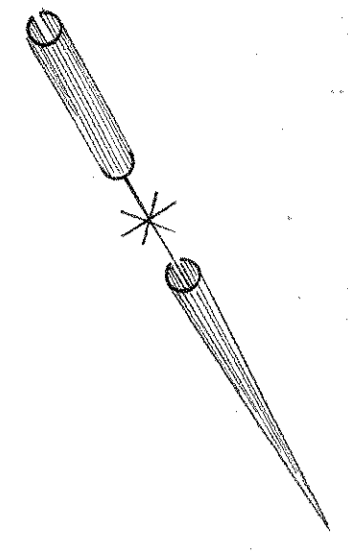

• Denotes Core Locations
See Str. Shts. 59 & 60 for chloride content of cores.
* Jt. dimensions taken at Temp. 53."

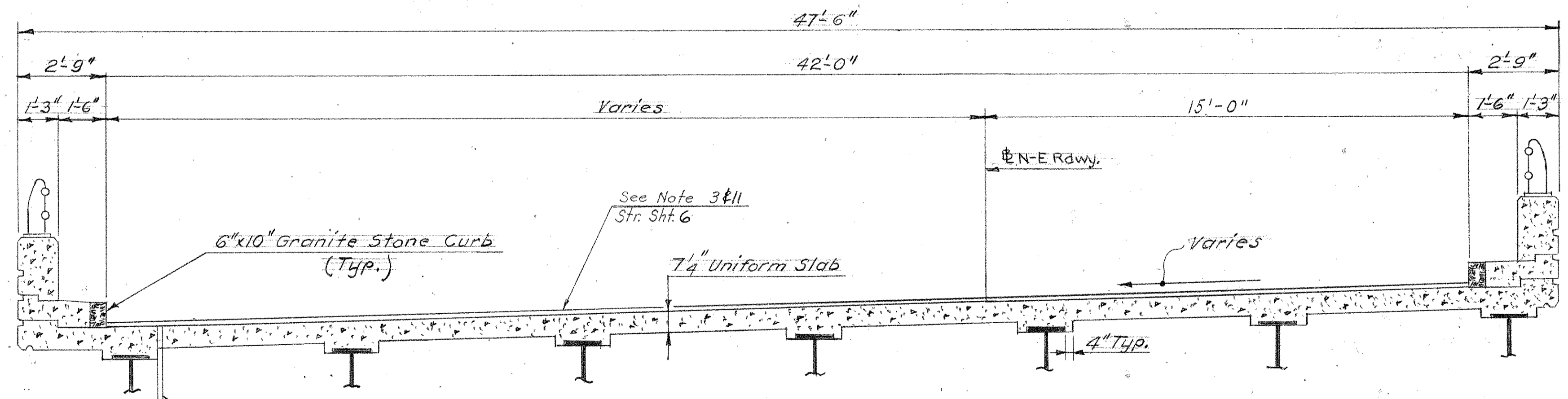

BRIDGE NO. 340I-B
TYPICAL BRIDGE SECTION SECTION D-D
Scale: 3/8" = 1'-0"

Note: For Section 12-12 see Str. Sht. 82.

CONNECTICUT			
DEPARTMENT OF TRANSPORTATION			
SOUTHINGTON - HARTFORD			
INTERSTATE ROUTE 84			
59 STRUCTURES			
DECK REPAIRS			
ON RAMP TO E. B. I-84 FROM SISSON AVE.			
ENGINEER BRIDGE DESIGN UNIT			
DESIGNER J.P.L.	DRAFTER G.O.K.	CHECKER G.D.B.	
APPROVED <i>[Signature]</i>	DATE 3/17/82		
NO. DATE	DESCRIPTION	BRIDGE LOG NO. 340I B	STRUCTURE SHEET NO. 57 of 87
REVISIONS		STRUCTURE NO. 131-145-340I B	

THE INFORMATION, INCLUDING ESTIMATED QUANTITIES OF WORK SHOWN ON THESE SHEETS IS BASED ON LIMITED INVESTIGATIONS BY THE STATE AND IS IN NO WAY WARRANTED TO INDICATE THE TRUE CONDITIONS OR ACTUAL QUANTITIES OR DISTRIBUTION OF QUANTITIES OF WORK WHICH WILL BE REQUIRED.

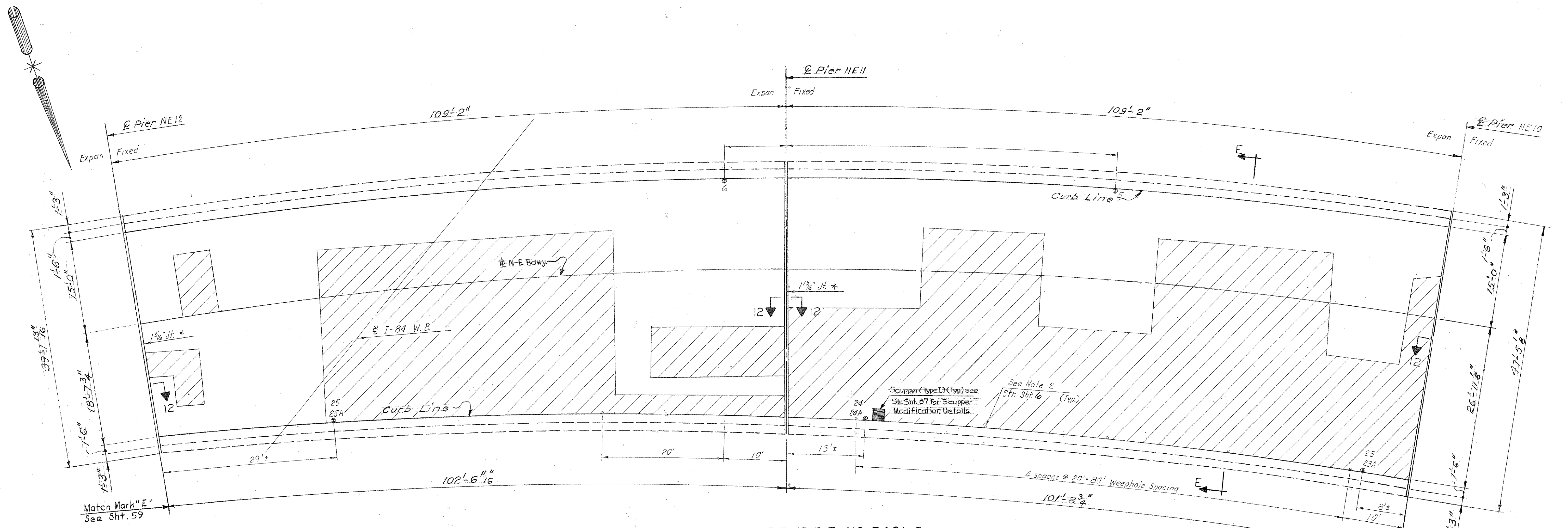

DECK PLAN-BRIDGE NO. 3401-B
SCALE 1/8" = 1'-0"

• Denotes Core Location.
* Jt. dimensions taken at Temp. 58°

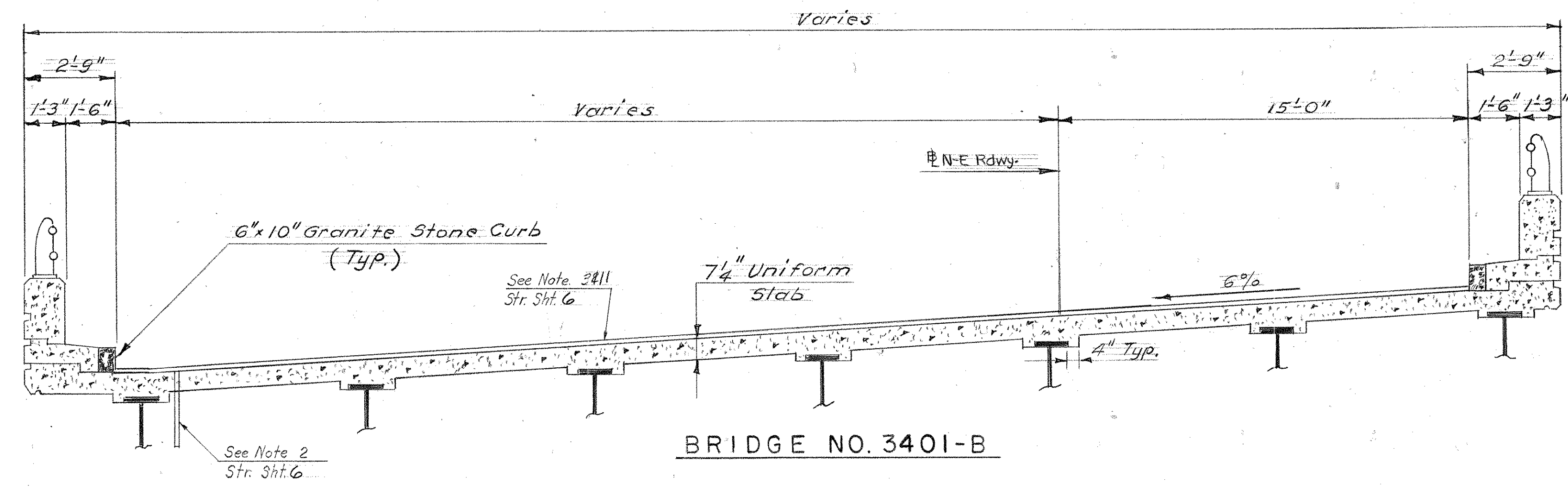

TYPICAL BRIDGE SECTION SECTION E-E
Scale: 3/8" = 1'-0"

BR. NO. 3401A

CORE NO.	CHLORIDE CONTENT		WATER SOLUBLE	
	% BY WT.	LBS/CY	% BY WT.	LBS/CY
1	0.065	2.548		
1A	0.004	0.157		
2	0.087	3.410	0.074	2.901
2A	0.004	0.157		
3	0.061	2.391		
3A	0.006	0.235		
4	0.009	0.353		
5	0.004	0.157		
6	0.004	0.157		
7	0.004	0.157		
8	0.004	0.157		
9	0.006	0.235		
10	0.003	0.118		

CONTINUED ON STR. SHT. 59

Note: For Section 12-12 see Str. Sht. 82

CONNECTICUT
DEPARTMENT OF TRANSPORTATION

SOUTHINGTON - HARTFORD

INTERSTATE ROUTE 84
59 STRUCTURES
DECK REPAIRS

ON RAMP TO E.B. I-84 FROM SISSION AVE.

ENGINEER BRIDGE DESIGN UNIT

DESIGNER J.P.L.	DRAFTER G.O.K.	CHECKER G.D.B.
APPROVED <i>[Signature]</i>	DATE 3/17/82	

BRIDGE LOG NO. 3401B STRUCTURE SHEET NO. 58 of 87

THE INFORMATION, INCLUDING ESTIMATED QUANTITIES OF WORK SHOWN ON THESE SHEETS IS BASED ON LIMITED INVESTIGATIONS BY THE STATE AND IS IN NO WAY WARRANTED TO INDICATE THE TRUE CONDITIONS OR ACTUAL QUANTITIES OR DISTRIBUTION OF QUANTITIES OF WORK WHICH WILL BE REQUIRED.

NO.	DATE	DESCRIPTION

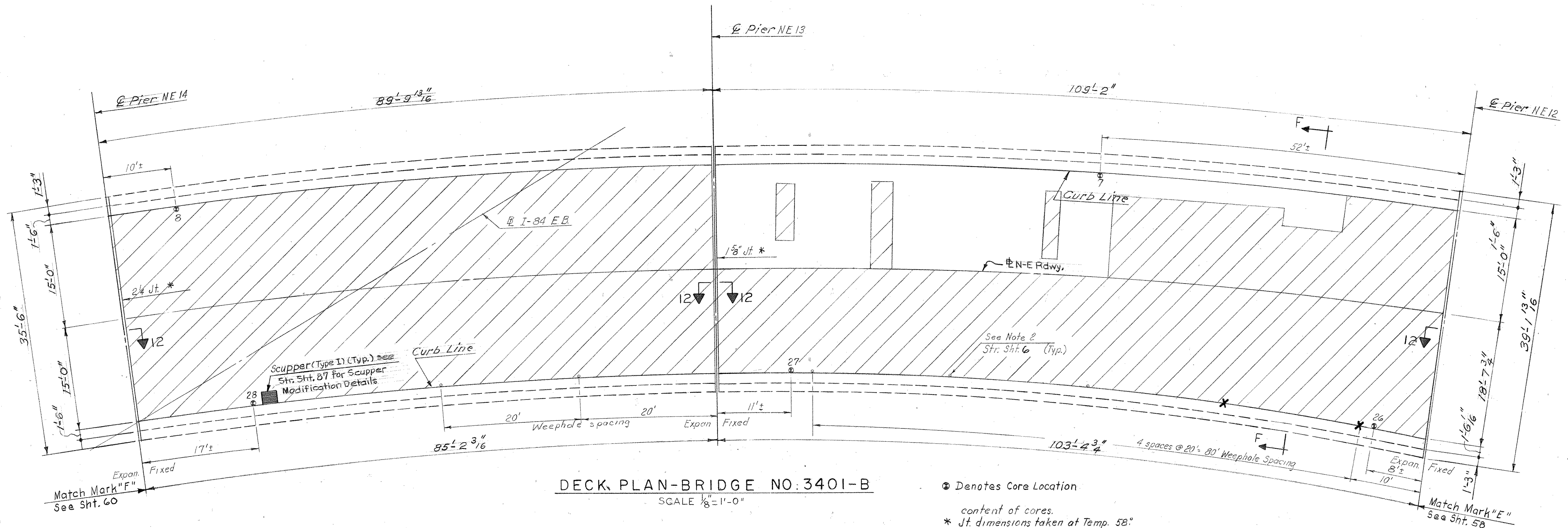
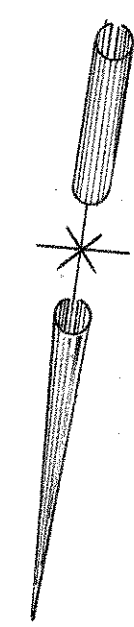

DECK PLAN-BRIDGE NO. 3401-B
SCALE 1/8" = 1'-0"

⊙ Denotes Core Location
content of cores.
* Jt. dimensions taken at Temp. 58°

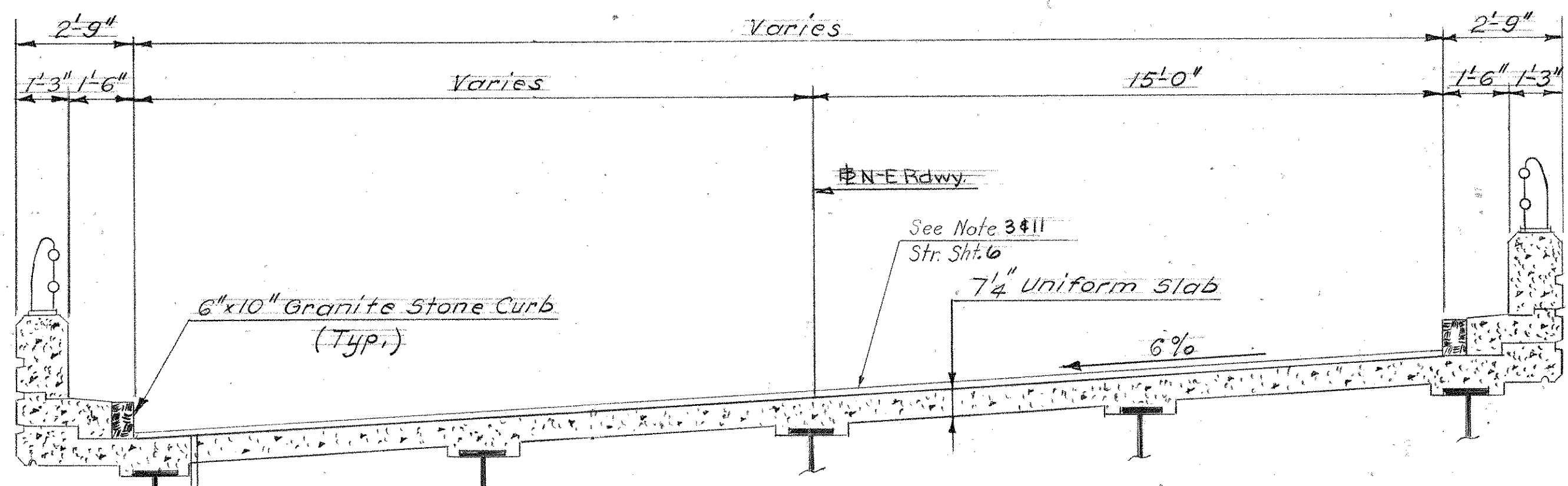

BRIDGE NO. 3401-B
TYPICAL BRIDGE SECTION SECTION F-F
Scale: 3/8" = 1'-0"

BR. NO. 3401B

CORE NO.	CHLORIDE CONTENT		WATER SOLUBLE	
	% BY WT. LBS./CY	% BY WT. LBS./CY	% BY WT. LBS./CY	% BY WT. LBS./CY
1	0.005	0.196		
2	0.029	1.137		
3	0.047	1.842		
3A	0.016	0.627		
4	0.014	0.549		
5	0.028	1.098		
6	0.013	0.510		
7	0.040	1.568		
8	0.034	1.333		
9	0.050	1.960		
9A	0.012	0.470		
10	0.004	0.157		
11	0.014	0.549		
12	0.003	0.118		
13	0.019	0.745		
14	0.011	0.431		
15	0.003	0.118		
16	0.016	0.627		
17	0.011	0.431		
18	0.021	0.823		
19	0.006	0.235		
20	0.014	1.724		
20A	0.003	0.118		
21	0.113	4.430		
21A	0.022	0.802		
22	0.160	6.272	0.153	5.998
22A	0.056	2.195		
23	0.208	8.154	0.194	7.605
23A	0.063	2.470		
24	0.097	3.802		

CONTINUED ON STR. SHT. 60

BR. NO. 3401A (Continued)

11	0.098	3.842	0.087	3.410
11A	0.043	1.686		
12	0.010	0.392		
13	0.011	0.431		
14	0.047	1.842		
15	0.061	2.391		
15A	0.005	0.196		
16	0.004	0.157		
17	0.003	0.118		
18	0.004	0.157		
19	0.003	0.118		
20	0.006	0.235		
21	0.007	0.274		
22	0.003	0.118		
23	0.036	1.411		
23A	0.005	0.196		
24	0.022	0.862		

Note: For Section 12-12 see Str. Sht. 82

CONNECTICUT
DEPARTMENT OF TRANSPORTATION
SOUTHINGTON-HARTFORD

INTERSTATE ROUTE 84
59 STRUCTURES
DECK REPAIRS

ON RAMP TO E.B. I-84 FROM SISSION AVE.

ENGINEER BRIDGE DESIGN UNIT
DESIGNER J.P.L. DRAFTER G.O.K. CHECKER G.D.B.

APPROVED *[Signature]* DATE 3/17/82

REVISIONS STRUCTURE NO. 131-145-3401B BRIDGE LOG NO. 3401B STRUCTURE SHEET NO. 59 of 87

THE INFORMATION, INCLUDING ESTIMATED QUANTITIES OF WORK SHOWN ON THESE SHEETS IS BASED ON LIMITED INVESTIGATIONS BY THE STATE AND IS IN NO WAY WARRANTED TO INDICATE THE TRUE CONDITIONS OR ACTUAL QUANTITIES OR DISTRIBUTION OF QUANTITIES OF WORK WHICH WILL BE REQUIRED.

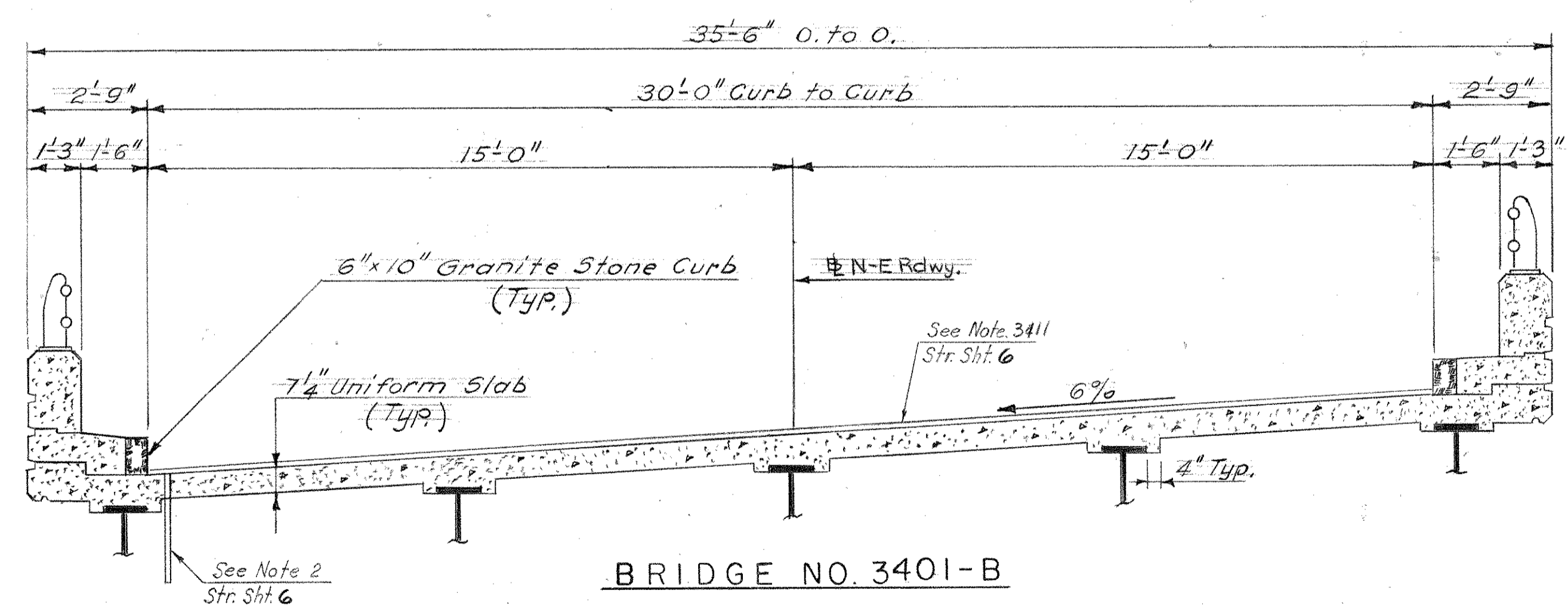
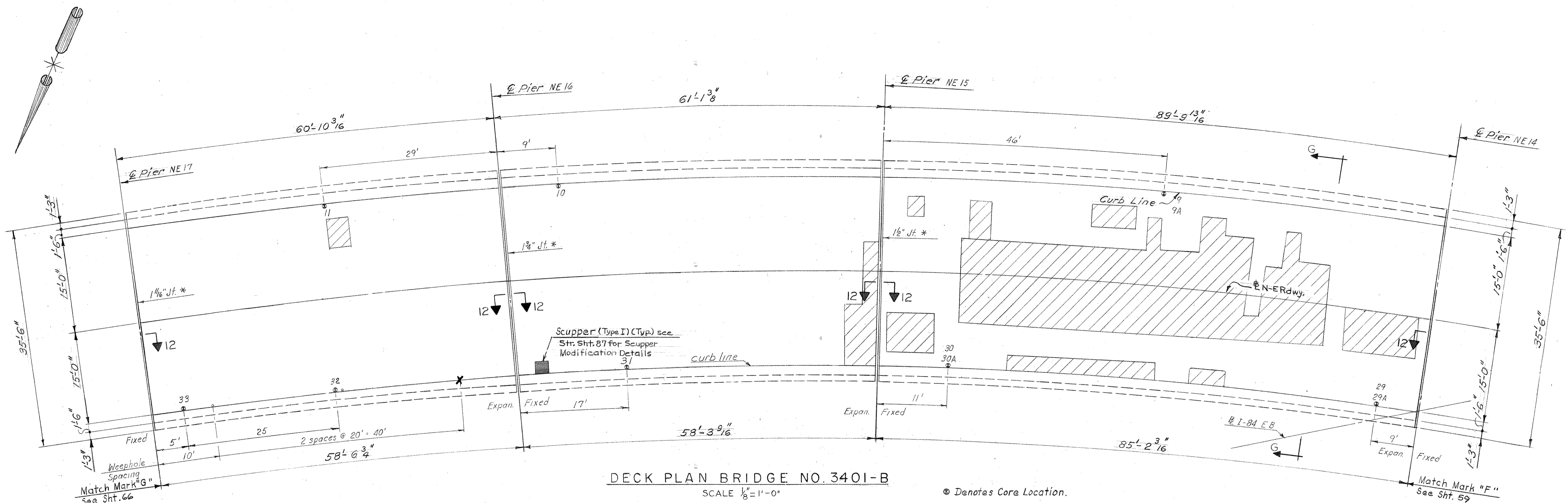

BR. NO. 3401B (Continued)

CORE NO.	CHLORIDE CONTENT		DATE 10/29/81	
	% BY WT	LBS/C.Y.	% BY WT	LBS/C.Y.
24A	0.028	1.098		
25	0.121	4.743		
25A	0.080	3.136		
26	0.028	1.098		
27	0.017	0.666		
28	0.016	0.627		
29	0.121	4.743	0.113	4.430
29A	0.019	0.744		
30	0.094	3.685		
30A	0.008	0.314		
31	0.042	1.646		
32	0.004	0.157		
33	0.005	0.196		
34	0.002	0.078		
35	0.008	0.314		
36	0.002	0.078		
37	0.002	0.078		
38	0.001	0.039		
39	0.001	0.039		
40	0.009	0.353		
41	0.001	0.039		

Note: For Section 12-12 see Str. Sht. 82

CONNECTICUT
DEPARTMENT OF TRANSPORTATION
SOUTHINGTON-HARTFORD
INTERSTATE ROUTE 84
59 STRUCTURES
DECK REPAIRS
ON RAMP TO E.B. I-84 FROM SISSON AVE.

ENGINEER BRIDGE DESIGN UNIT
DESIGNER J.P.L. DRAFTER G.O.K. CHECKER G.D.B.

NO.	DATE	DESCRIPTION	APPROVED	DATE
			<i>[Signature]</i>	3/17/82

STRUCTURE NO. 131-145-3401B BRIDGE LOG NO. 3401B STRUCTURE SHEET NO. 60 of 87

THE INFORMATION, INCLUDING ESTIMATED QUANTITIES OF WORK SHOWN ON THESE SHEETS IS BASED ON LIMITED INVESTIGATIONS BY THE STATE AND IS IN NO WAY WARRANTED TO INDICATE THE TRUE CONDITIONS OR ACTUAL QUANTITIES OR DISTRIBUTION OF QUANTITIES OF WORK WHICH WILL BE REQUIRED.

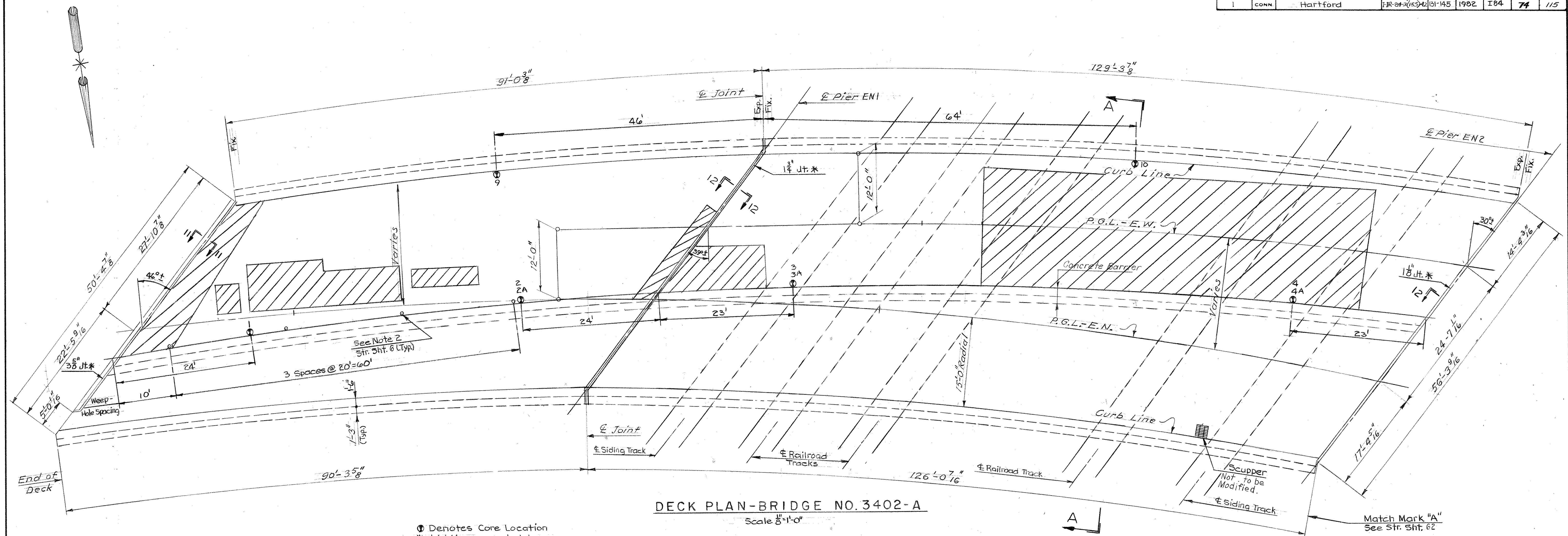

DECK PLAN-BRIDGE NO. 3402-A
Scale 3/8"=1'-0"

⊙ Denotes Core Location
* Joint Measurements taken 10-6-81 (Temp. 56°)

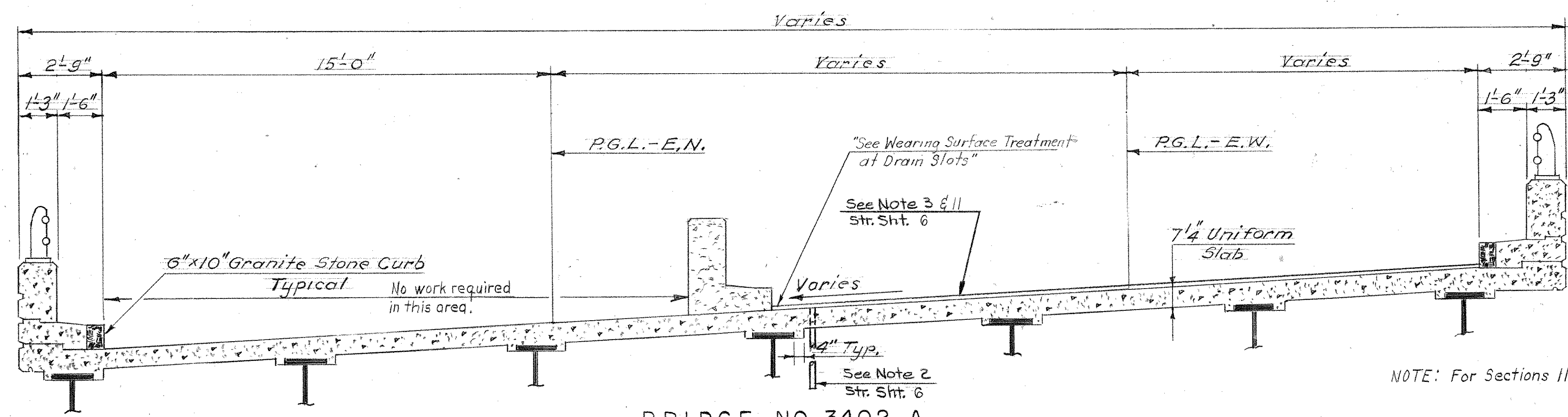

BRIDGE NO. 3402-A
SECTION A-A
Scale 3/8"=1'-0"

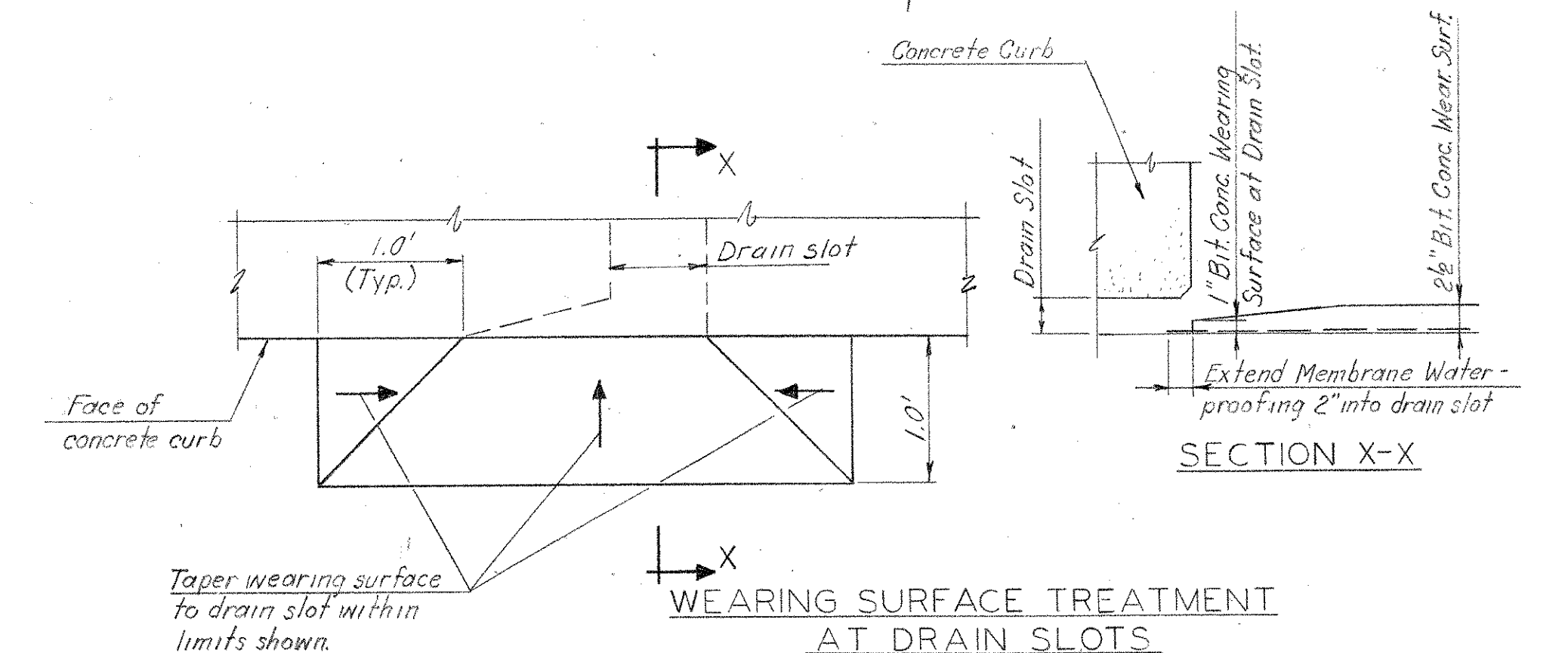

NOTE: For Sections 11-11 & 12-12, See Str. Sht. 82

THE INFORMATION, INCLUDING ESTIMATED QUANTITIES OF WORK SHOWN ON THESE SHEETS IS BASED ON LIMITED INVESTIGATIONS BY THE STATE AND IS IN NO WAY WARRANTED TO INDICATE THE TRUE CONDITIONS OR ACTUAL QUANTITIES OR DISTRIBUTION OF QUANTITIES OF WORK WHICH WILL BE REQUIRED.

CONNECTICUT DEPARTMENT OF TRANSPORTATION SOUTHWINGTON - HARTFORD INTERSTATE ROUTE 84 59 STRUCTURES DECK REPAIRS I-84 W.B. OFF RAMP TO SISSION AVE.			
ENGINEER Bridge Design Unit			
DESIGNER J.P.L.		DRAFTER G.O.K.	
CHECKER G.D.B.		DATE 3 17 82	
APPROVED <i>[Signature]</i>		DATE 3 17 82	
NO. DATE DESCRIPTION		BRIDGE LOG NO. STRUCTURE SHEET NO.	
REVISIONS		3402A 01 87	

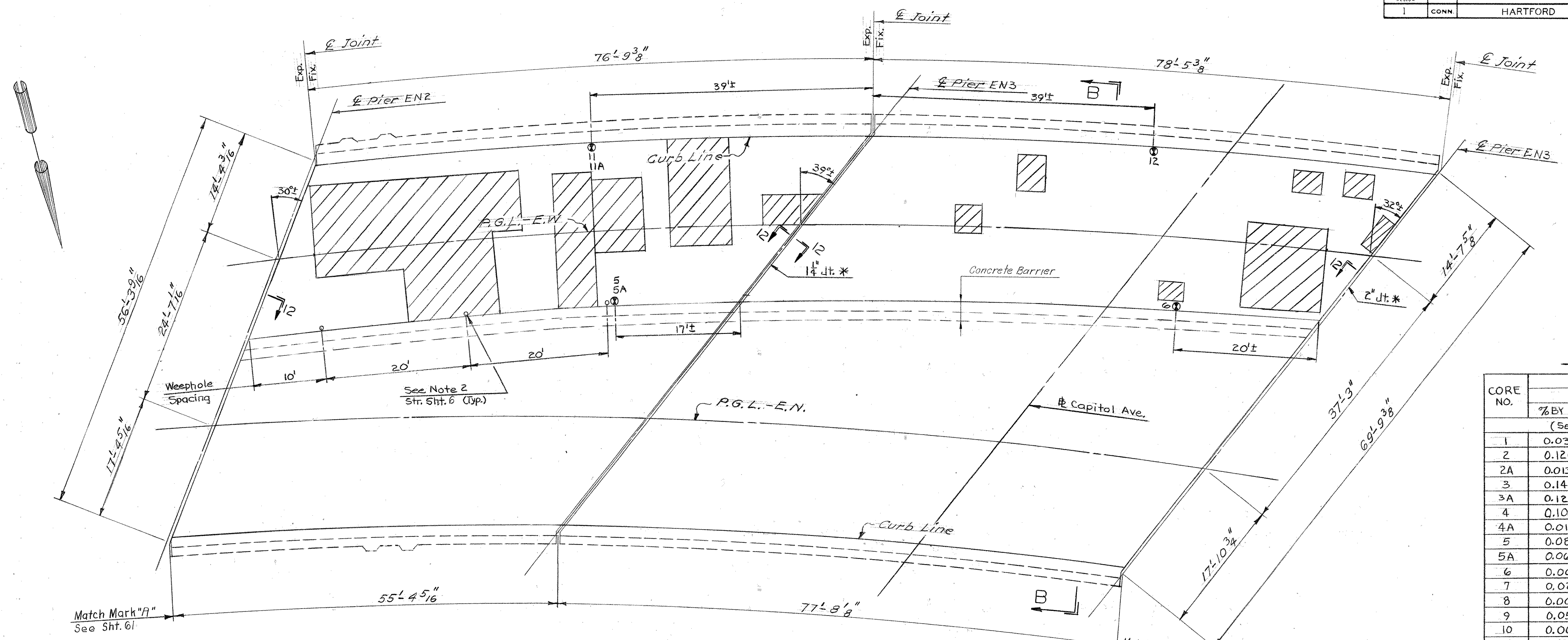

BRIDGE NO. 3402 A

CORE NO.	CHLORIDE CONTENT			
	TOTAL		WATER SOLUBLE	
	% BY WT.	LBS./C.Y.	% BY WT.	LBS./C.Y.
1	0.039	1.527		
2	0.120	4.704		
2A	0.013	0.510		
3	0.147	5.762	0.141	5.527
3A	0.128	5.018		
4	0.103	4.038		
4A	0.017	0.666		
5	0.085	3.332		
5A	0.066	2.587		
6	0.006	0.235		
7	0.021	0.823		
8	0.004	0.157		
9	0.050	1.960		
10	0.065	2.548		
11	0.126	4.939	0.119	4.664
11A	0.027	1.058		
12	0.024	0.941		
13	0.039	1.529		

(See Note 4 Str. Sht. 6 Date 11-3-81)

NOTE: For Section 12-12, See Str. Sht. 82.

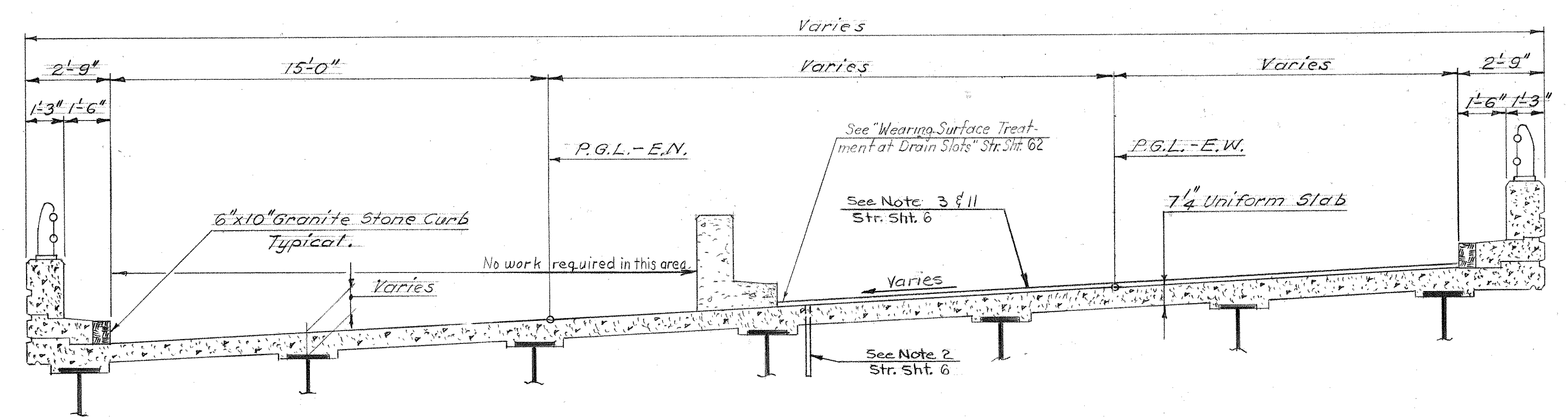

THE INFORMATION, INCLUDING ESTIMATED QUANTITIES OF WORK SHOWN ON THESE SHEETS IS BASED ON LIMITED INVESTIGATIONS BY THE STATE AND IS IN NO WAY WARRANTED TO INDICATE THE TRUE CONDITIONS OR ACTUAL QUANTITIES OR DISTRIBUTION OF QUANTITIES OF WORK WHICH WILL BE REQUIRED.

CONNECTICUT			
DEPARTMENT OF TRANSPORTATION			
SOUTHINGTON - HARTFORD			
INTERSTATE ROUTE 84			
59 STRUCTURES			
DECK REPAIRS			
I-84 W.B. OFF RAMP TO SISSION AVE			
ENGINEER BRIDGE DESIGN UNIT			
DESIGNER J.P.L.	DRAFTER G.O.K.	CHECKER G.D.B.	
APPROVED <i>[Signature]</i>	DATE 3/17/82		
NO. DATE	DESCRIPTION	APPROVED	DATE
REVISIONS		STRUCTURE NO. 131-145-3402A	BRIDGE LOG NO. 3402A
		STRUCTURE SHEET NO. 62 OF 87	

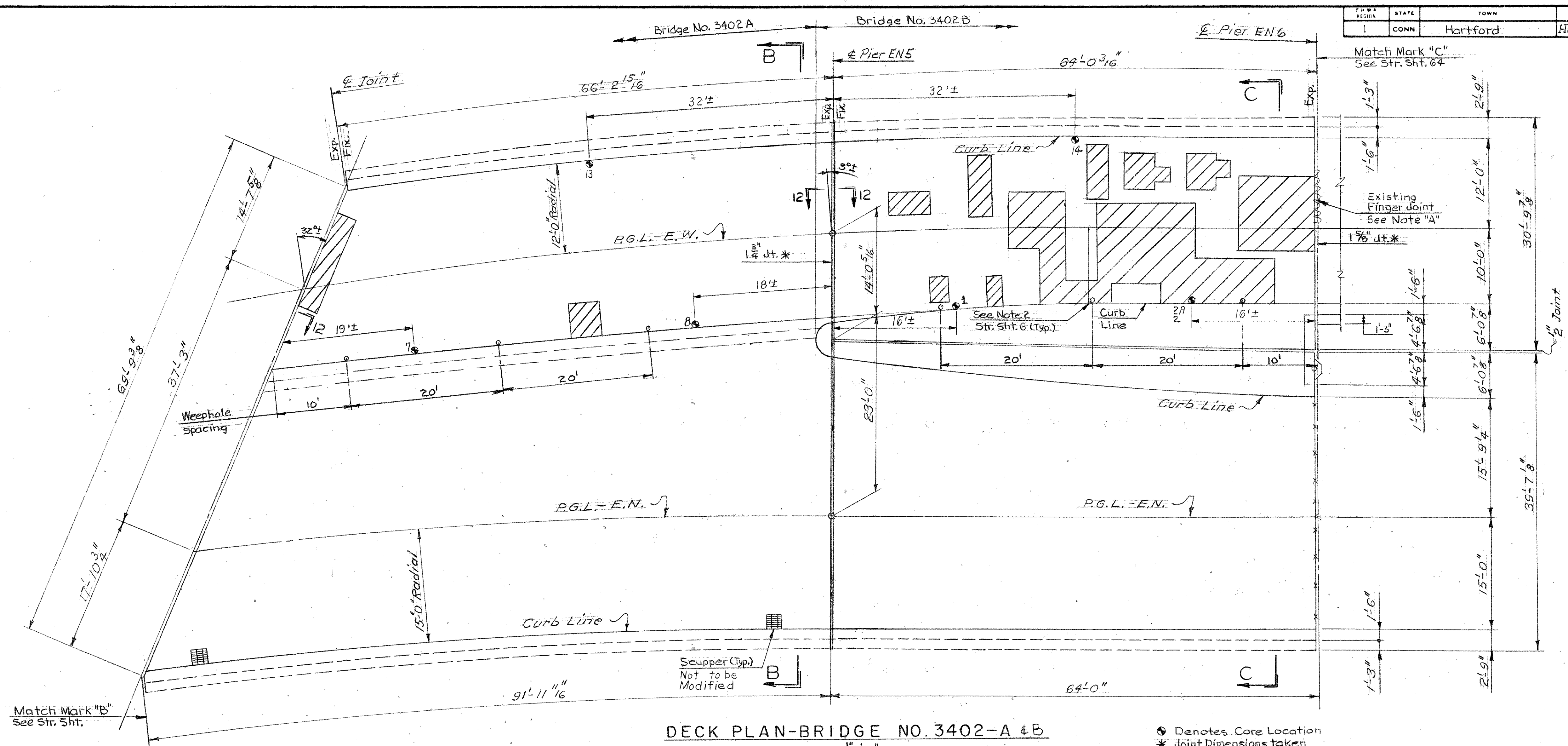

DECK PLAN-BRIDGE NO. 3402-A & B
 Scale 3/8"=1'-0"

● Denotes Core Location
 * Joint Dimensions taken 10-6-81 (Temp. 56°)

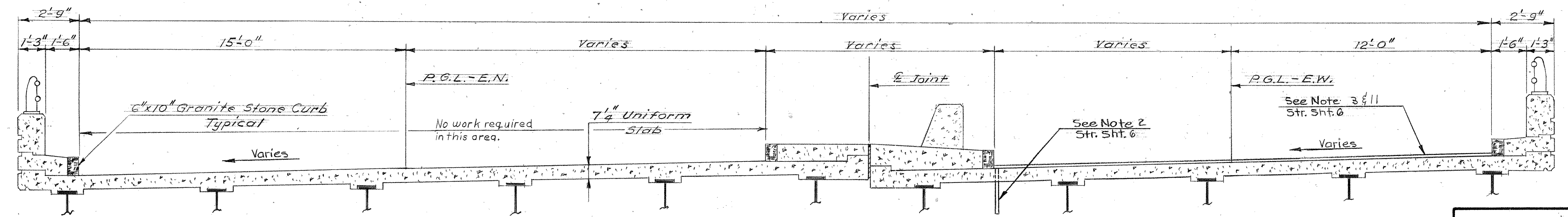

BRIDGE NO. 3402 B
 SECTION C-C
 Scale 3/8"=1'-0"

Note "A": Existing finger joint shall be modified as shown on Str. Sht. 79.
 Note: For Section 12-12, See Str. Sht. 82.

CORE NO.	CHLORIDE CONTENT		%	BY WT. LBS/CY.
	TOTAL	WATER SOLUBLE		
1	0.004	0.157	---	---
2	0.041	1.607	---	---
2A	0.025	0.980	---	---
14	0.003	0.118	---	---

THE INFORMATION, INCLUDING ESTIMATED QUANTITIES OF WORK SHOWN ON THESE SHEETS IS BASED ON LIMITED INVESTIGATIONS BY THE STATE AND IS IN NO WAY WARRANTED TO INDICATE THE TRUE CONDITIONS OR ACTUAL QUANTITIES OR DISTRIBUTION OF QUANTITIES OF WORK WHICH WILL BE REQUIRED.

CONNECTICUT
 DEPARTMENT OF TRANSPORTATION
 SOUTHINGTON - HARTFORD

INTERSTATE ROUTE 84

59 STRUCTURES
 DECK REPAIRS

I-84 W.B. OFF RAMP TO SISSION AVE.

ENGINEER Bridge Design Unit
 DESIGNER J.P.L. DRAFTER G.O.K. CHECKER G.D.B.

NO.	DATE	DESCRIPTION	APPROVED	DATE
				3/17/82

STRUCTURE NO. 131-145-3402A&B
 BRIDGE LOG NO. 3402A&B
 STRUCTURE SHEET NO. 63 of 87

FED. AID REGION	STATE	TOWN	FED. AID PROJ. NO.	PROJ. NO.	YEAR	ROUTE NO.	SHEET NO.	TOTAL SHEETS
1	CONN.	Hartford	I-R-84-3(55)12	131-145	1982	I-84	77	115

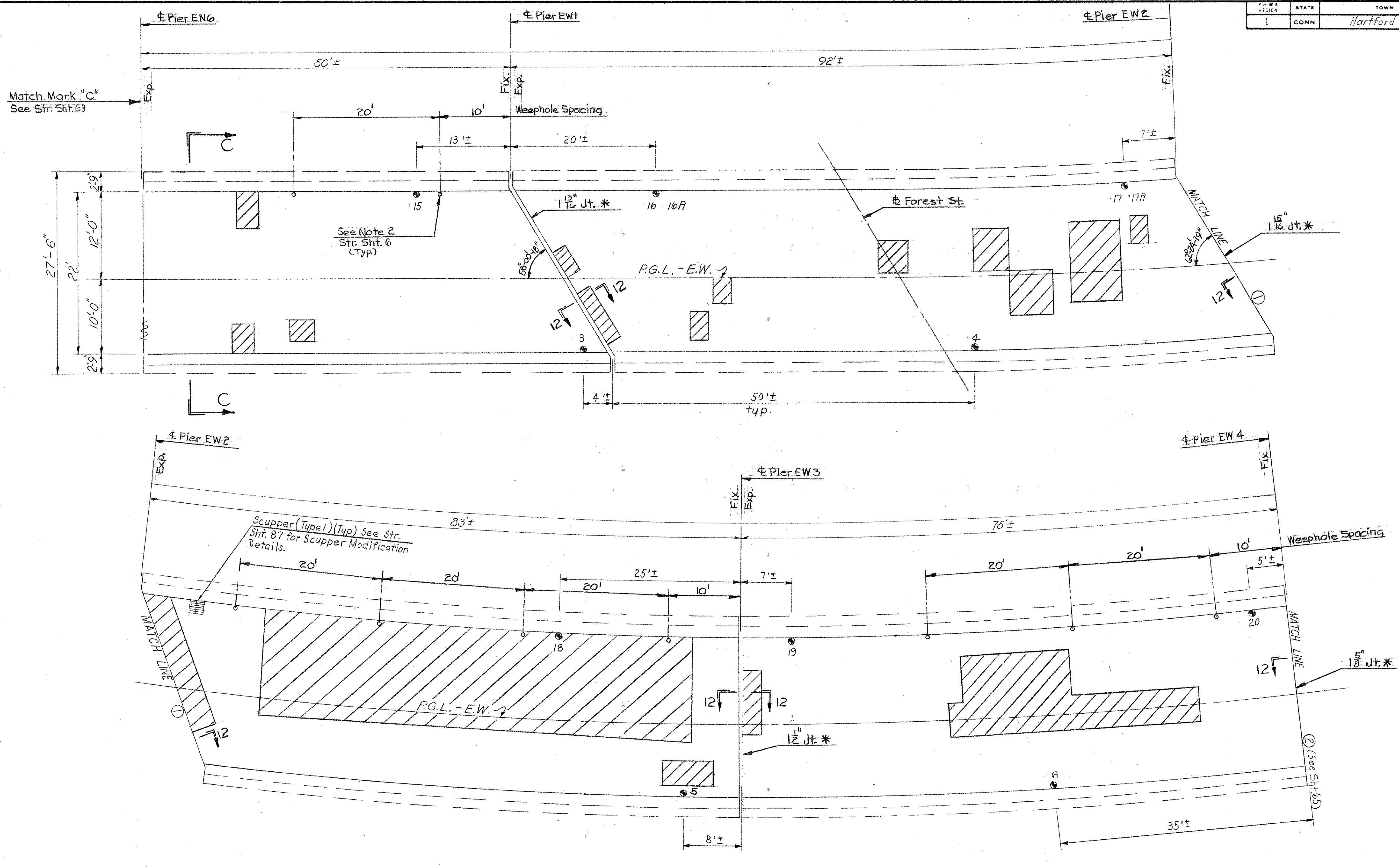
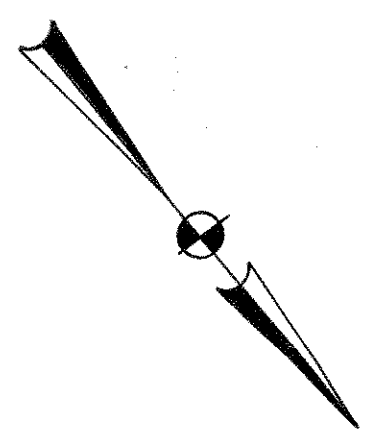

I-84 W.B. OFF RAMP TO SISSON AVE.
Scale 1/8" = 1'-0"

⊙ Denotes Core Location
* Joint Dimensions taken 10-6-81 (Temp. 56°)

CORE NO.	CHLORIDE CONTENT		WATER SOLUBLE	
	% BY WT.	LBS./CY.	% BY WT.	LBS./CY.
(See Note 4 Str. Sht. 6 Date 11/13/81)				
3	0.022	0.862		
4	0.023	0.902		
5	0.005	0.196		
6	0.004	0.157		
15	0.003	0.118		
16	0.133	5.214	0.125	4.900
16A	0.005	0.196		
17	0.046	1.803		
17A	0.004	0.157		
18	0.006	0.235		
19	0.002	0.078		
20	0.084	3.293		

THE INFORMATION, INCLUDING ESTIMATED QUANTITIES OF WORK SHOWN ON THESE SHEETS IS BASED ON LIMITED INVESTIGATIONS BY THE STATE AND IS IN NO WAY WARRANTED TO INDICATE THE TRUE CONDITIONS OR ACTUAL QUANTITIES OR DISTRIBUTION OF QUANTITIES OF WORK WHICH WILL BE REQUIRED.

CONNECTICUT			
DEPARTMENT OF TRANSPORTATION			
SOUTHINGTON - HARTFORD			
INTERSTATE ROUTE 84			
59 STRUCTURES			
DECK REPAIRS			
W.B. OFF RAMP TO SISSON AVE.			
ENGINEER BRIDGE DESIGN UNIT			
DESIGNER J.P.L.		DRAFTER J.J.C.	CHECKER G.D.B.
APPROVED <i>[Signature]</i>		DATE 3/17/82	
NO. DATE		DESCRIPTION	
REVISIONS		STRUCTURE NO. 131-145-03402B	
		BRIDGE LOG NO. 03402B	STRUCTURE SHEET NO. 64 of 87

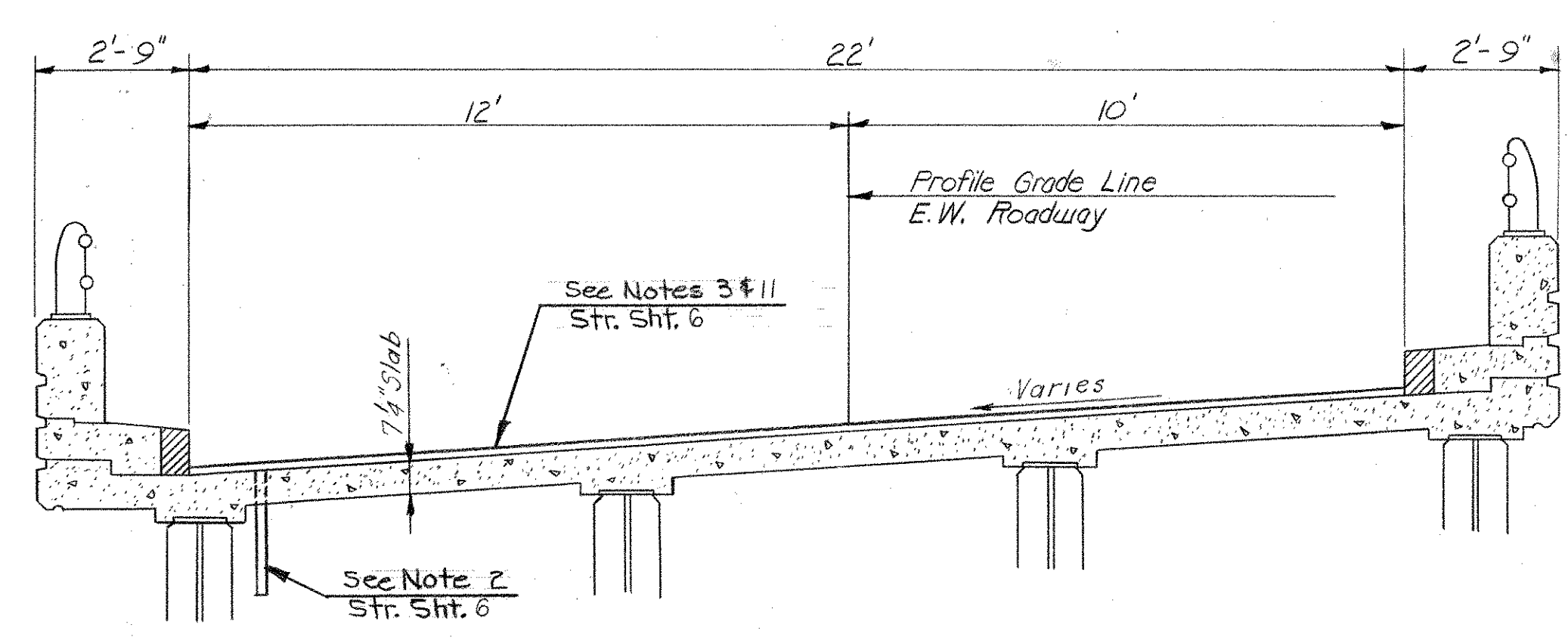
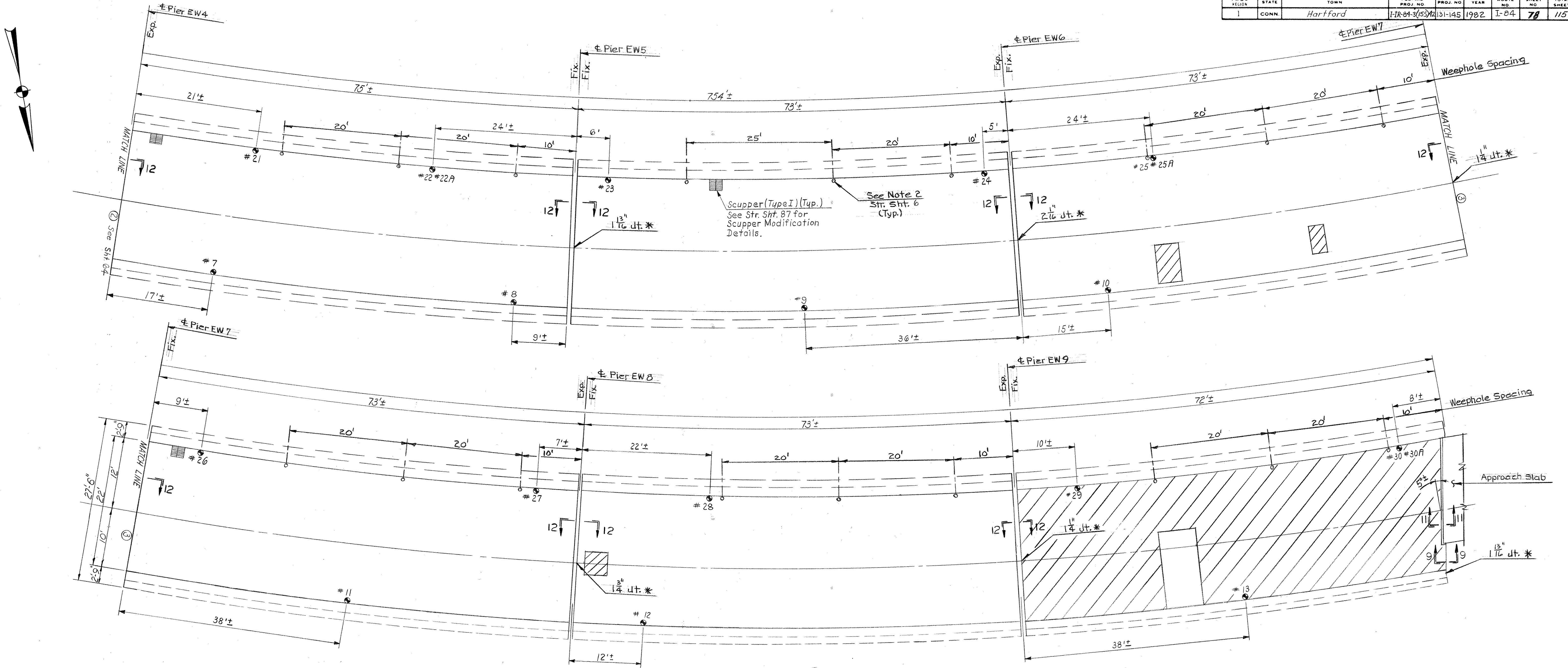

BRIDGE NO. 3402 B
SECTION C-C
Scale 3/8" = 1'-0"

BRIDGE NO. 3402 B

CORE NO.	CHLORIDE CONTENT		WATER SOLUBLE	
	% BY WT.	LBS./CY.	% BY WT.	LBS./CY.
7	0.002	0.078		
8	0.001	0.039		
9	0.003	0.118		
10	0.010	0.392		
11	0.018	0.706		
12	0.021	0.823		
13	0.032	1.254		
21	0.005	0.196		
22	0.050	1.960		
22A	0.004	0.157		
23	0.005	0.196		
24	0.020	0.784		
25	0.073	2.862		
25A	0.006	0.235		
26	0.015	0.588		
27	0.012	0.470		
28	0.029	1.137		
29	0.015	0.588		
30	0.157	6.154	0.146	5.723
30A	0.020	0.784		

• Denotes Core Location
 * Joint Dimensions taken 10-6-81 (Temp. 56°)
 I-84 W.B. OFF RAMP TO SISSON AVE
 SCALE 1/8" = 1'-0"

Note: For Section 9-9, See Str. Sht. 86
 For Section 11-11 & 12-12, See Str. Sht. 82.

THE INFORMATION, INCLUDING ESTIMATED QUANTITIES OF WORK SHOWN ON THESE SHEETS IS BASED ON LIMITED INVESTIGATIONS BY THE STATE AND IS IN NO WAY WARRANTED TO INDICATE THE TRUE CONDITIONS OR ACTUAL QUANTITIES OR DISTRIBUTION OF QUANTITIES OF WORK WHICH WILL BE REQUIRED.

CONNECTICUT			
DEPARTMENT OF TRANSPORTATION			
SOUTHINGTON - HARTFORD			
INTERSTATE ROUTE 84			
59 STRUCTURES			
DECK REPAIRS			
W.B. OFF RAMP TO SISSON AVE.			
ENGINEER BRIDGE DESIGN UNIT			
DESIGNER J.P.L.		DRAFTER J.J.C.	CHECKER G.D.B.
APPROVED <i>[Signature]</i>		DATE 3/17/82	
NO.	DATE	DESCRIPTION	REVISIONS
STRUCTURE NO. 131-145-03402 B		BRIDGE LOG NO. 03402B	STRUCTURE SHEET NO. 65 of 87

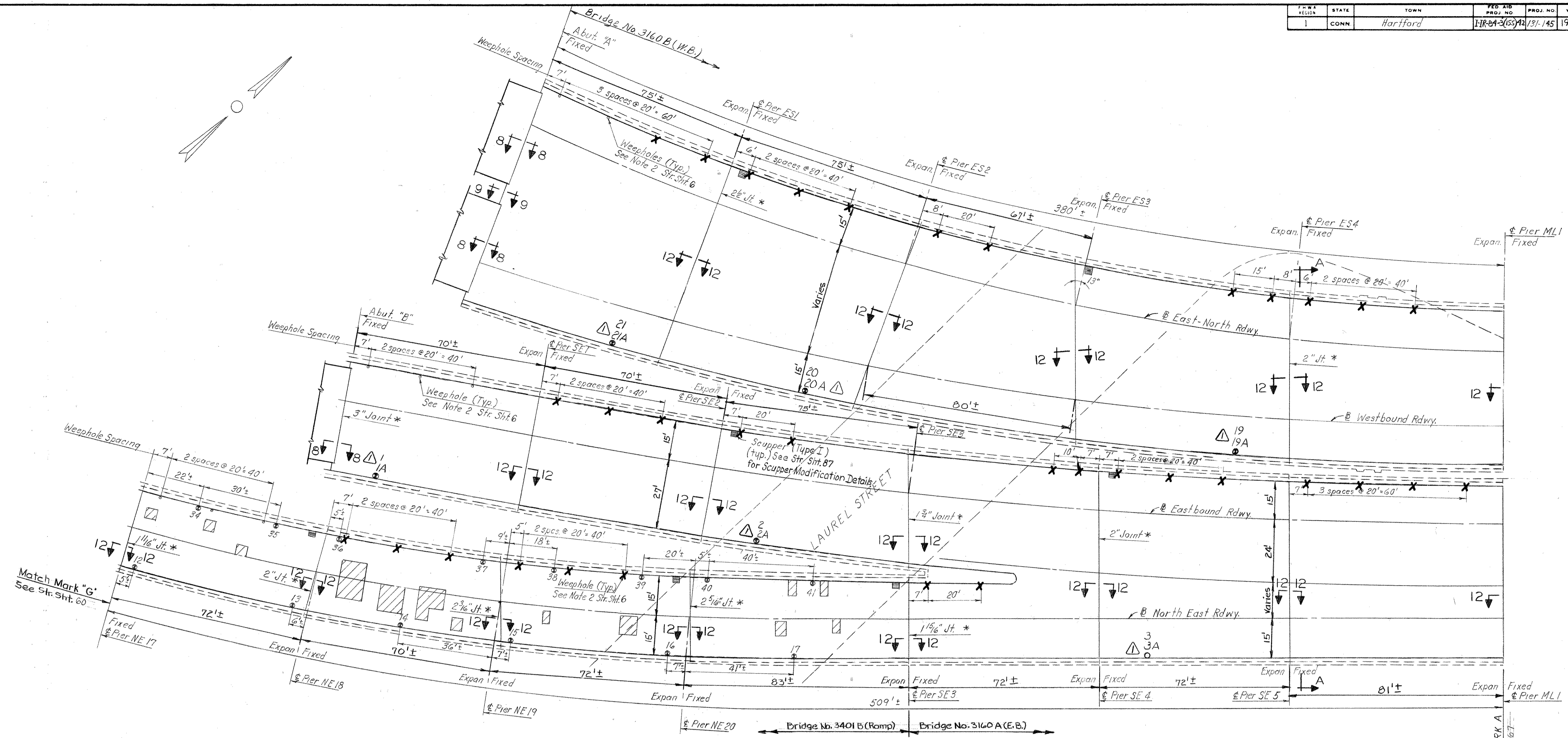

DECK PLAN
BR. NO. 3160 A & B
Scale 1" = 20'

• Denotes Core Location
 * Jt. dimensions on Bridge No. 3401B (Ramp) were taken at a temperature of 53°. Jt. dimensions on Bridge No. 3160 A & B were taken on 11-20-81. For Chloride Analysis of Bridge No. 3401B (Ramp) see Str. Sht. 59 & 60. Deck condition survey of Br. No. 3160 A & B done on 8-19-81.

Note: For Sections 8-8 & 9-9, See Str. Sht. 86.
 For Sections 12-12 See Str. Sht. 82.

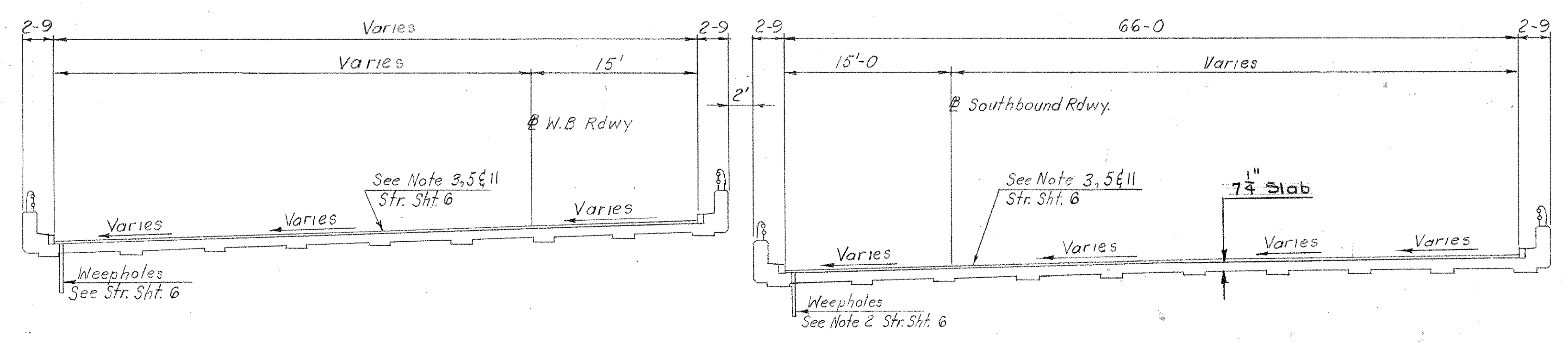

SECTION A-A
Scale 1/2" = 1'-0"

THE INFORMATION, INCLUDING ESTIMATED QUANTITIES OF WORK SHOWN ON THESE SHEETS IS BASED ON LIMITED INVESTIGATIONS BY THE STATE AND IS IN NO WAY WARRANTED TO INDICATE THE TRUE CONDITIONS OR ACTUAL QUANTITIES OR DISTRIBUTION OF QUANTITIES OF WORK WHICH WILL BE REQUIRED.

CONNECTICUT		
DEPARTMENT OF TRANSPORTATION		
SOUTHINGTON - HARTFORD		
INTERSTATE ROUTE 84		
59 STRUCTURES		
DECK REPAIRS		
E.B. & W.B. I-84 - VIADUCTS		
6/82	Chloride Samples Added	
ENGINEER BRIDGE DESIGN UNIT		
DESIGNER J.P.L.	DRAFTER T.S.R.	CHECKER G.D.B.
NO. DATE	DESCRIPTION	APPROVED DATE
		<i>W. O. Johnson</i> 3/17/82
REVISIONS		STRUCTURE NO. 131-145-3401B-3160A#B
		BRIDGE LOG NO. 3401B-3160A#B
		STRUCTURE SHEET NO. 66 of 87

F.H.W.A. REGION	STATE	TOWN	FED. AID PROJ. NO.	PROJ. NO.	YEAR	ROUTE NO.	SHEET NO.	TOTAL SHEETS
1	CONN.	Hartford	11P-84-3160A2	131-145	1982	I-84	79A	115

BR. NO. 3160A				
CORE NO.	CHLORIDE TOTAL		CONTENT WATER SOLUBLE	
	% BY WT. LBS./C.Y.		% BY WT. LBS./C.Y.	
	(See Note 4 Str. Sht. 6) Date 5/5/82			
1	0.031	1.215	0.026	1.019
1A	0.003	0.118		
2	0.022	0.862		
2A	0.007	0.274		
3	0.002	0.078		
3A	0.002	0.078		
4	0.009	0.353		
4A	0.004	0.157		
5	0.006	0.235		
5A	0.003	0.118		
6	0.050	1.960	0.042	1.646
6A	0.029	1.137		
7	0.021	0.823		
7A	0.002	0.078		
8	0.058	2.274	0.050	1.960
8A	0.050	1.960		
9	0.017	0.666		
9A	0.002	0.078		
10	0.019	0.745		
10A	0.004	0.157		
11	0.039	1.529	0.034	1.333
11A	0.017	0.666		
12	0.041	1.607	0.033	1.294
12A	0.020	0.784		
13	0.115	4.508	0.100	3.920
13A	0.070	2.744		
14	0.076	2.979	0.064	2.509
14A	0.055	2.156		
15	0.023	0.902		
15A	0.002	0.078		
16	0.009	0.353		
16A	0.003	0.118		
17	0.019	0.745		
17A	0.002	0.078		
18	0.044	1.725	0.038	1.490
18A	0.032	1.254		
19	0.003	0.118		
19A	0.003	0.118		
20	0.010	0.392		
20A	0.004	0.157		
21	0.028	1.098	0.023	0.902
21A	0.004	0.157		
22	0.010	0.392		
22A	0.003	0.118		

BR. NO. 3160B				
CORE NO.	CHLORIDE TOTAL		CONTENT WATER SOLUBLE	
	% BY WT. LBS./C.Y.		% BY WT. LBS./C.Y.	
	(See Note 4 Str. Sht. 6) Date 5/5/82			
1	0.008	0.314		
1A	0.002	0.078		
2	0.052	2.038	0.044	1.725
2A	0.028	1.098		
3	0.026	1.058	0.023	0.902
3A	0.011	0.431		
4	0.030	1.176	0.025	0.980
4A	0.005	0.186		
5	0.026	1.019	0.021	0.823
5A	0.003	0.118		
6	0.028	1.098	0.023	0.902
6A	0.016	0.627		
7	0.013	0.510		
7A	0.002	0.078		
8	0.065	2.548	0.055	2.156
8A	0.032	1.254		
9	0.065	2.548	0.054	2.117
9A	0.023	0.902		
10	0.023	0.902		
10A	0.006	0.235		
11	0.023	0.902		
11A	0.014	0.549		
12	0.069	2.705	0.061	2.391
12A	0.016	0.627		
13	0.034	1.333	0.028	1.098
13A	0.014	0.549		
14	0.034	1.333	0.026	1.019
14A	0.013	0.510		
15	0.010	0.392		
15A	0.003	0.118		
16	0.022	0.862		
16A	0.006	0.235		
17	0.012	0.470		
17A	0.003	0.118		
18	0.021	0.823		
18A	0.003	0.118		
19	0.021	0.823		
19A	0.016	0.627		
20	0.012	0.470		
20A	0.003	0.118		
21	0.013	0.510		
21A	0.003	0.118		

CONNECTICUT			
DEPARTMENT OF TRANSPORTATION			
SOUTHINGTON - HARTFORD			
INTERSTATE ROUTE 84			
59 STRUCTURES			
DECK REPAIRS			
E.B. & W.B. I-84 - VIADUCTS			
ENGINEER BRIDGE DESIGN UNIT			
DESIGNER J. R. L.		CHECKER G. D. B.	
DRAFTSMAN T. S. R.		DATE	
NO.	DATE	DESCRIPTION	DATE
REVISIONS		STRUCTURE NO. 131-145-3401B-3160 A#B	
		BRIDGE LOG NO. 3401B-3160 A#B	STRUCTURE SHEET NO. 66A of 87

△	6/82	This Sheet added

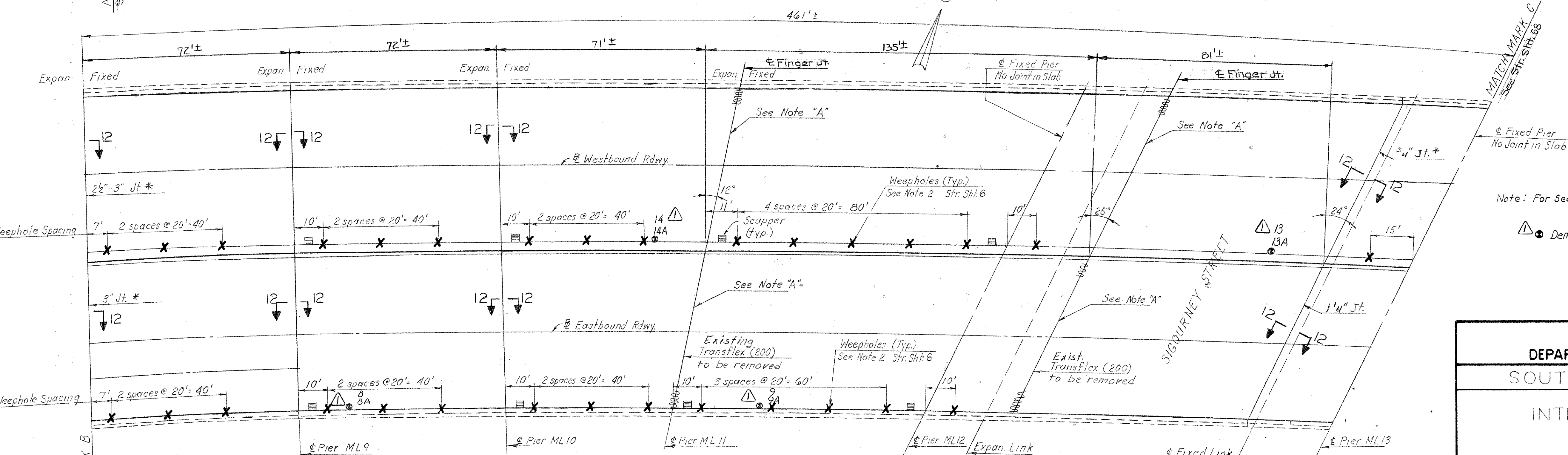
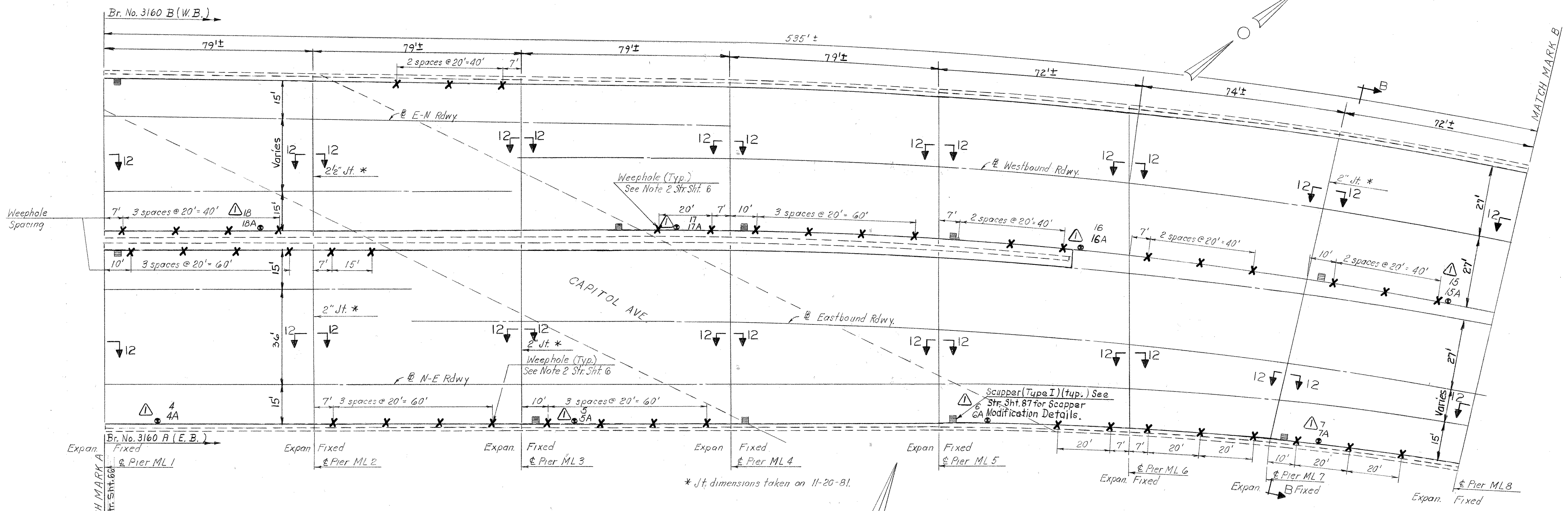

For Section B-B see Str. Sht. 69
 Note: For Section 12-12 see Str. Sht. 82.

△ Denotes Core Locations

CONNECTICUT			
DEPARTMENT OF TRANSPORTATION			
SOUTHINGTON - HARTFORD			
INTERSTATE ROUTE 84			
59 STRUCTURES			
DECK REPAIRS			
E.B. & W.B. I-84 - VIADUCTS			
ENGINEER BRIDGE DESIGN UNIT		DESIGNER J.P.L. DRAFTER T.S.R. CHECKER G.D.B.	
NO.	DATE	DESCRIPTION	APPROVED
			DATE 3/17/82
REVISIONS		STRUCTURE NO. 131-145-3160 A&B	BRIDGE LOG NO. 3160 A&B STRUCTURE SHEET NO. 67 of 87

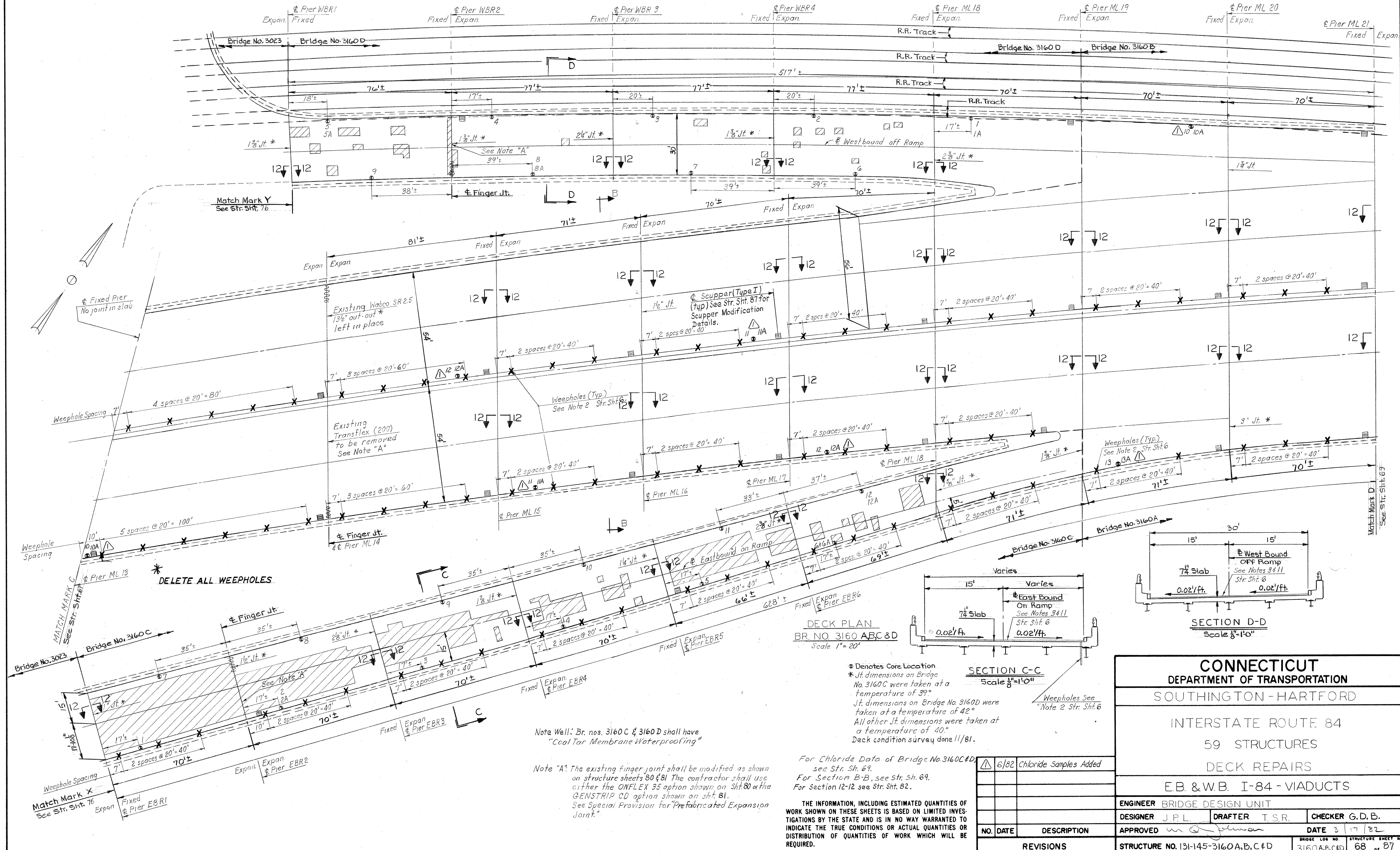

CONNECTICUT
DEPARTMENT OF TRANSPORTATION
SOUTHINGTON - HARTFORD
INTERSTATE ROUTE 84
59 STRUCTURES
DECK REPAIRS
E.B. & W.B. I-84 - VIADUCTS

ENGINEER	BRIDGE DESIGN UNIT		
DESIGNER	J.P.L.	DRAFTER	T.S.R.
CHECKER	G.D.B.		
NO.	DATE	DESCRIPTION	DATE
			3/17/82
REVISIONS		STRUCTURE NO. 131-145-3160A,B,C & D	BRIDGE LOG NO. 3160A,B,C & D
			STRUCTURE SHEET NO. 68 OF 87

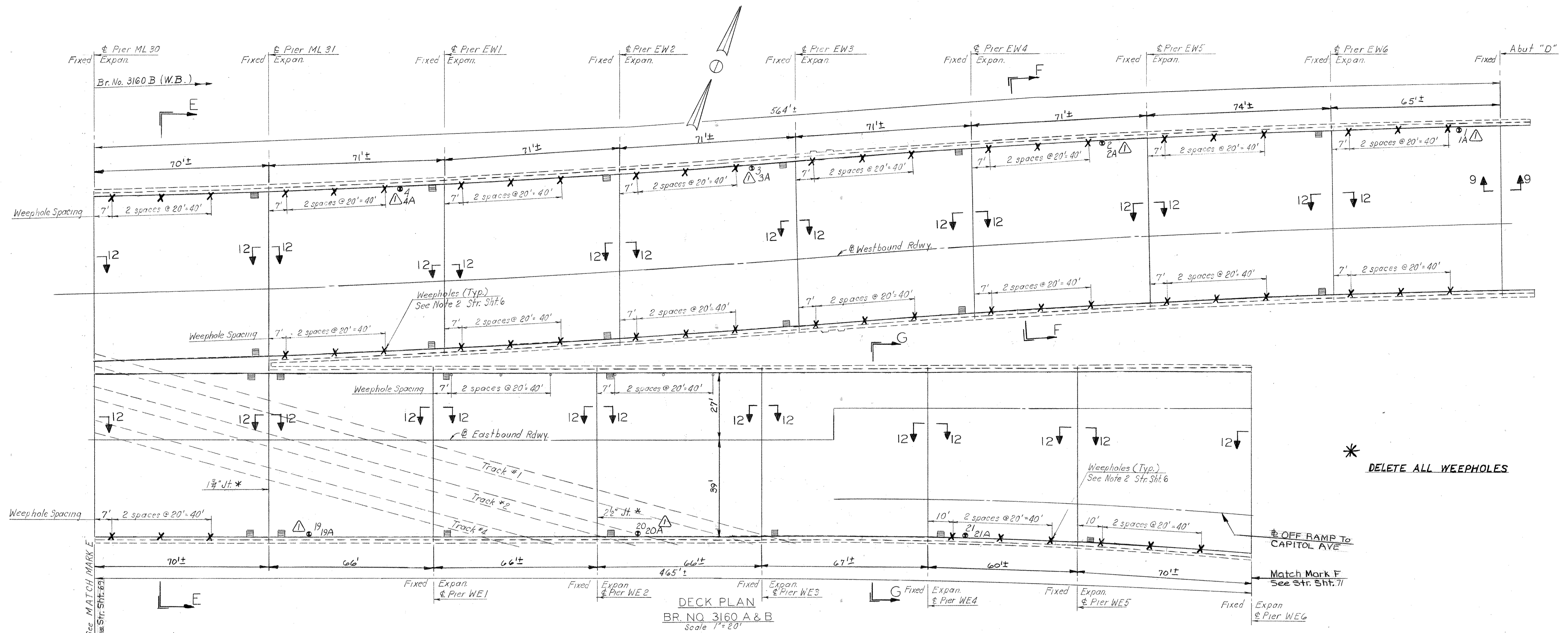

See MATCH MARK E (See Str. Sht. 81)

* Jt. dimension taken on 11-20-81

△ Denotes Core Locations

Note: For Section 9-9 See Str. Sh. 86
For Section 12-12 See Str. Sh. 82

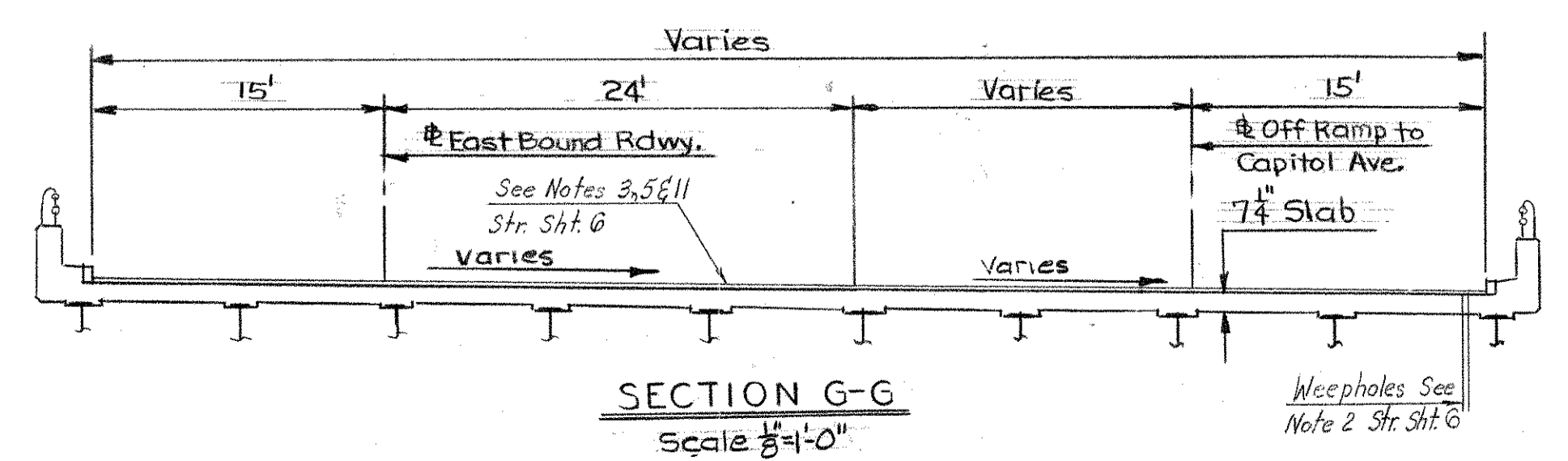
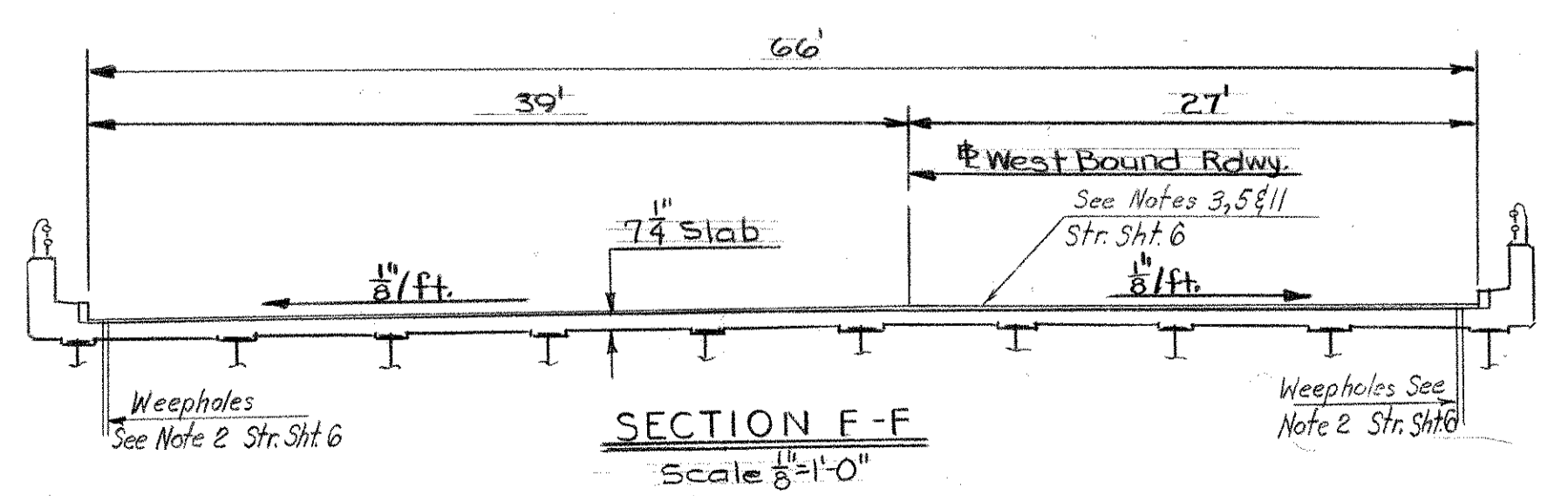
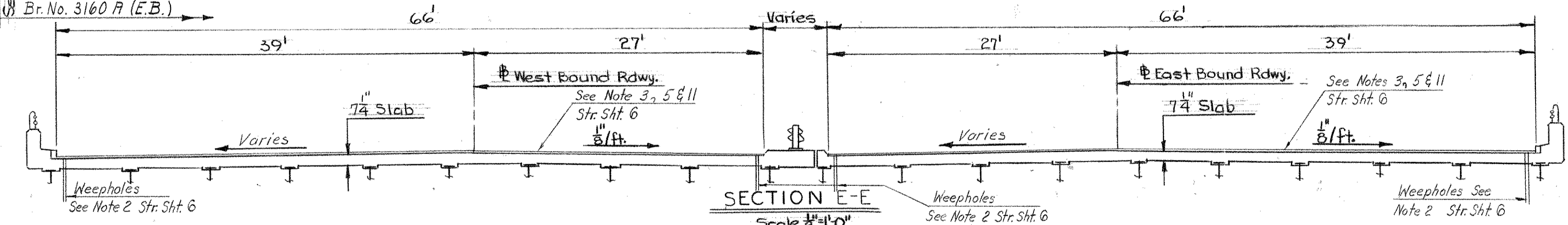

THE INFORMATION, INCLUDING ESTIMATED QUANTITIES OF WORK SHOWN ON THESE SHEETS IS BASED ON LIMITED INVESTIGATIONS BY THE STATE AND IS IN NO WAY WARRANTED TO INDICATE THE TRUE CONDITIONS OR ACTUAL QUANTITIES OR DISTRIBUTION OF QUANTITIES OF WORK WHICH WILL BE REQUIRED.

CONNECTICUT			
DEPARTMENT OF TRANSPORTATION			
SOUTHINGTON - HARTFORD			
INTERSTATE ROUTE 84			
59 STRUCTURES			
DECK REPAIRS			
E.B. & W.B. I-84 - VIADUCTS			
ENGINEER BRIDGE DESIGN UNIT			
DESIGNER	J.P.L.	DRAFTER	T.S.R.
CHECKER	G.D.B.		
NO.	DATE	DESCRIPTION	DATE
			3/17/82
REVISIONS		STRUCTURE NO. 131-145-3160 A & B	BRIDGE LOG NO. 3160 A & B
		STRUCTURE SHEET NO. 70	87

FWA REGION	STATE	TOWN	FED AID PROJ. NO.	PROJ. NO.	YEAR	ROUTE NO.	SHEET NO.	TOTAL SHEETS
1	CONN.	Hartford	1-R-3160A	31-145	1982	I-84	84	115

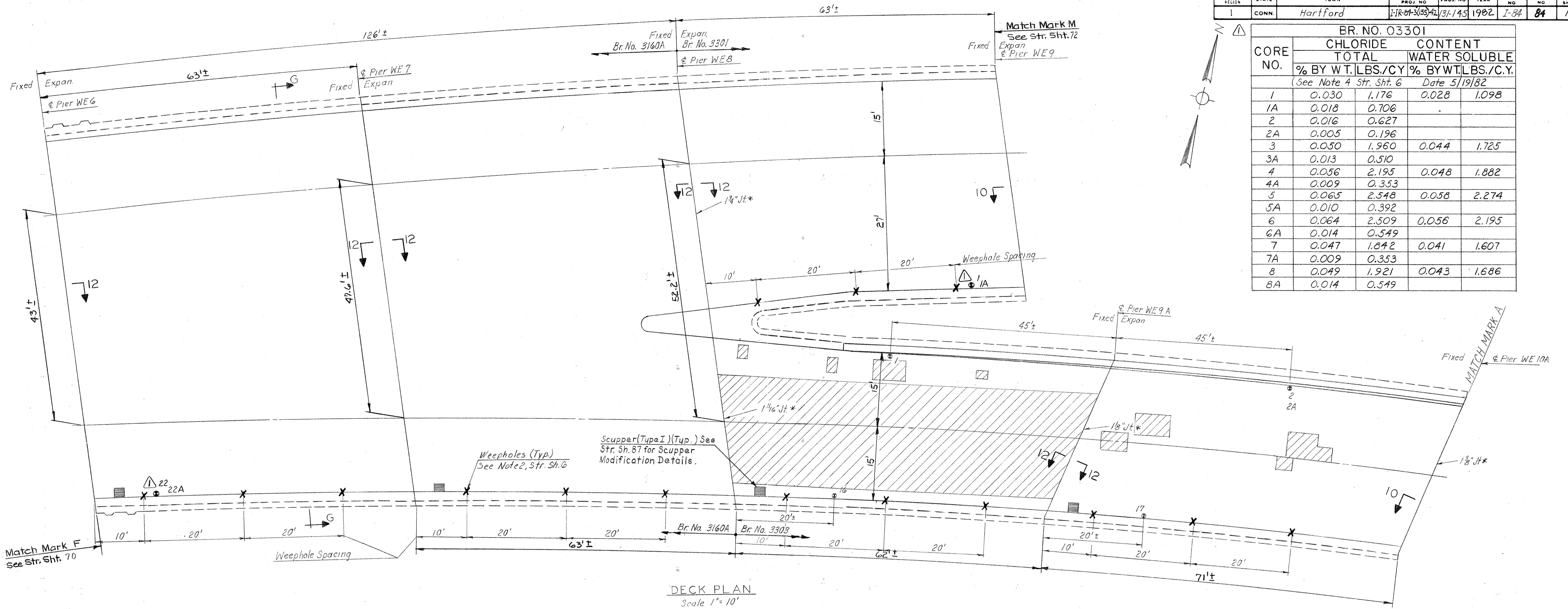

CORE NO.	CHLORIDE CONTENT			
	TOTAL		WATER SOLUBLE	
	% BY WT.	LBS./CY	% BY WT.	LBS./CY.
1	0.030	1.176	0.028	1.098
1A	0.018	0.706		
2	0.016	0.627		
2A	0.005	0.196		
3	0.050	1.960	0.044	1.725
3A	0.013	0.510		
4	0.056	2.195	0.048	1.882
4A	0.009	0.353		
5	0.065	2.548	0.058	2.274
5A	0.010	0.392		
6	0.064	2.509	0.056	2.195
6A	0.014	0.549		
7	0.047	1.842	0.041	1.607
7A	0.009	0.353		
8	0.049	1.921	0.043	1.686
8A	0.014	0.549		

(See Note 4 Str. Sht. 6 Date 5/19/82)

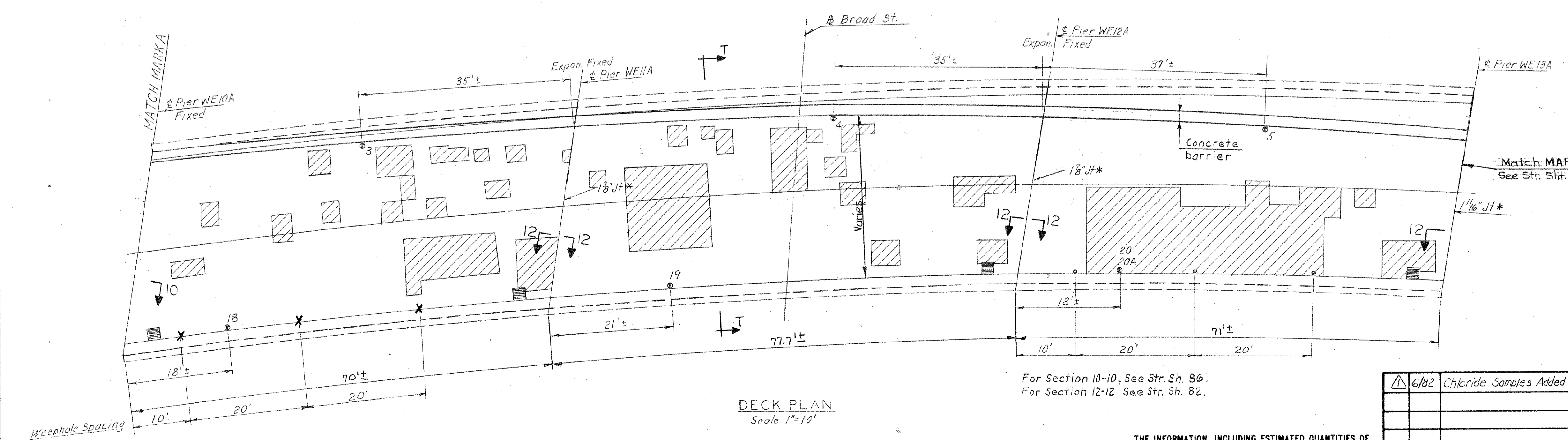

X DENOTES DELETED WEEPHOLES.

• Denotes Core Location
 * Jt. dimensions taken: Br. 3160A 11-20-81
 Br. 3303 10-23-81 (Temp 59°)
 Br. 3301 8-12-81
 Note: For Chloride Analysis of Br. 3303 see Str. Sht. 75
 For Section T-T see Str. Sht. 74
 For Section G-G see Str. Sht. 70
 Deck Condition Survey (Br. No. 3303) done 10/25/81.

CONNECTICUT			
DEPARTMENT OF TRANSPORTATION			
SOUTHINGTON - HARTFORD			
INTERSTATE ROUTE 84			
59 STRUCTURES			
DECK REPAIRS			
E.B. I-84 - VIADUCT			
ENGINEER BRIDGE DESIGN UNIT		DESIGNER J.P.L. DRAFTER T.S.R. CHECKER G.D.B.	
APPROVED [Signature]		DATE 3/17/82	
NO.	DATE	DESCRIPTION	REVISIONS

THE INFORMATION, INCLUDING ESTIMATED QUANTITIES OF WORK SHOWN ON THESE SHEETS IS BASED ON LIMITED INVESTIGATIONS BY THE STATE AND IS IN NO WAY WARRANTED TO INDICATE THE TRUE CONDITIONS OR ACTUAL QUANTITIES OR DISTRIBUTION OF QUANTITIES OF WORK WHICH WILL BE REQUIRED.

6/82	Chloride Samples Added

X DENOTES DELETED WEEPHOLES

F.H.W.A. REGION	STATE	TOWN	FED. AID PROJ. NO.	PROJ. NO.	YEAR	ROUTE NO.	SHEET NO.	TOTAL SHEETS
1	CONN.	Hartford	I-84-30(82)	131-145	1982	I-84	85	115

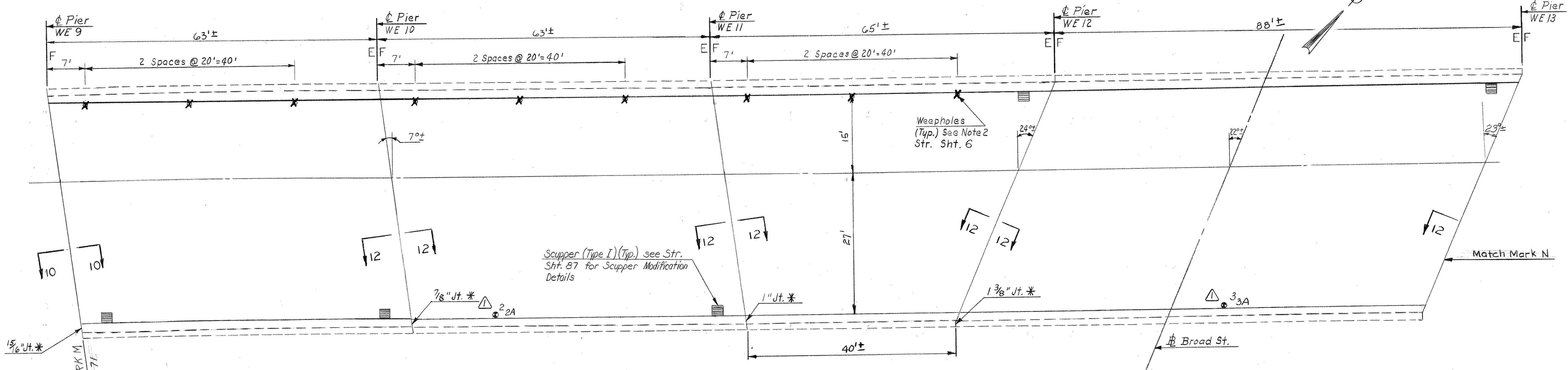

DECK PLAN
 Scale 1" = 10'
 * Jt. Dimensions Taken On 8-12-81.

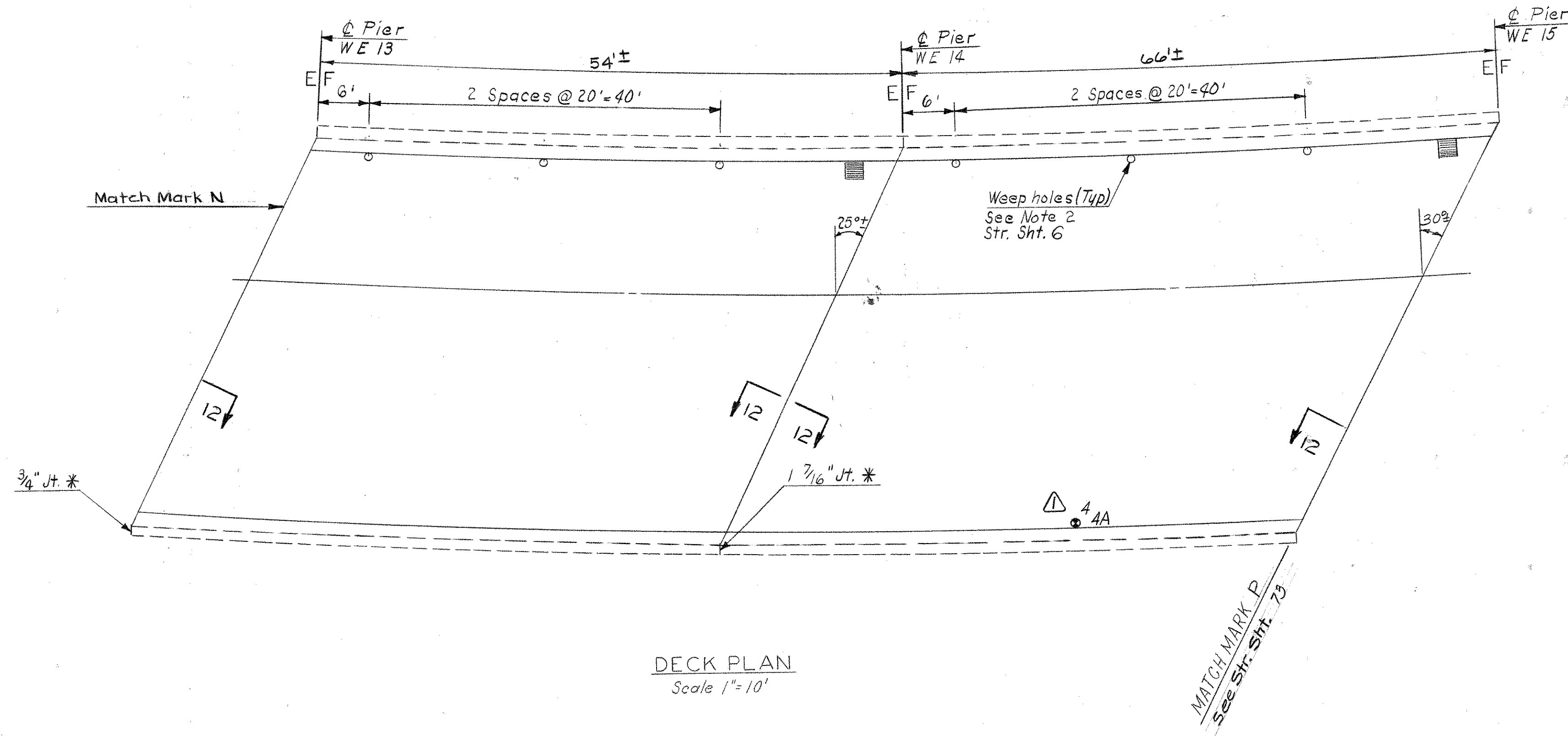

DECK PLAN
 Scale 1" = 10'

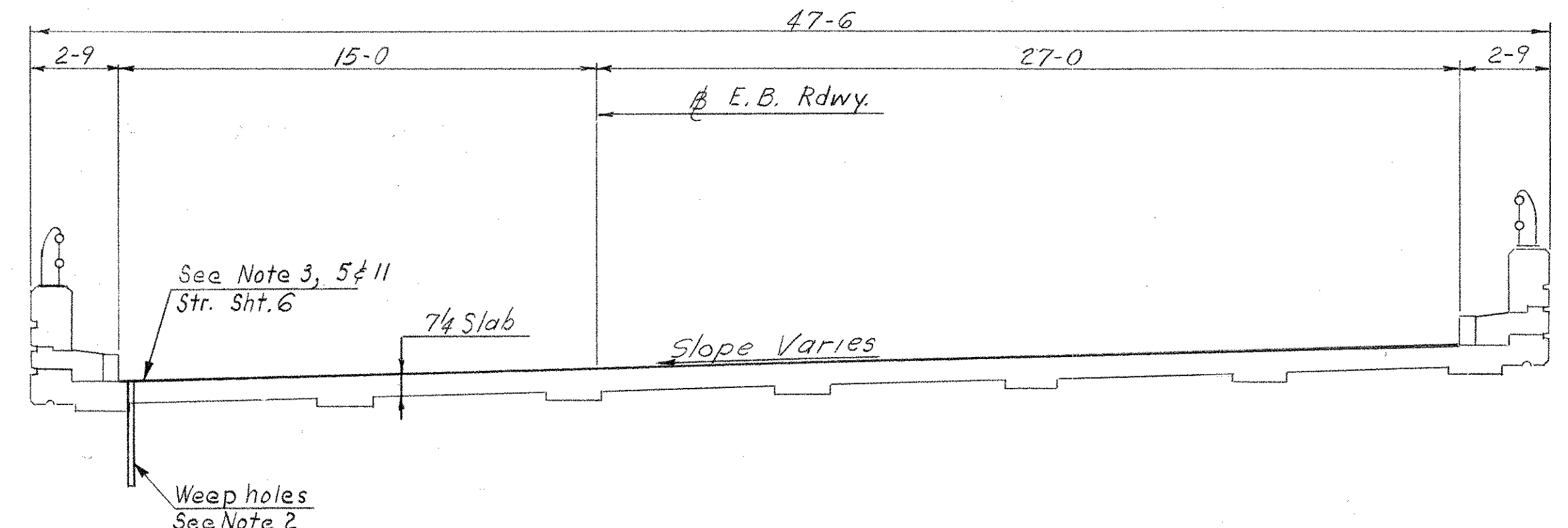

TYPICAL CROSS SECTION
 Scale 1/4" = 1'-0"

△ • Denotes Core Locations

Note: For Section 10-10 see Str. Sht. 86
 For Section 12-12 see Str. Sht. 82

CONNECTICUT DEPARTMENT OF TRANSPORTATION			
SOUTHINGTON - HARTFORD			
INTERSTATE ROUTE 84			
59 STRUCTURES			
DECK REPAIRS			
I-84 E.B. OVER BROAD ST. & RAMPS			
ENGINEER BRIDGE DESIGN UNIT		CHECKER G.D.B.	
DESIGNER J.P.L.	DRAFTER T.S.R.	DATE 3/17/82	
NO.	DATE	DESCRIPTION	APPROVED
			<i>[Signature]</i>
REVISIONS		STRUCTURE NO. 131-145-3301	BRIDGE LOG NO. 3301
			STRUCTURE SHEET NO. 72 of 87

THE INFORMATION, INCLUDING ESTIMATED QUANTITIES OF WORK SHOWN ON THESE SHEETS IS BASED ON LIMITED INVESTIGATIONS BY THE STATE AND IS IN NO WAY WARRANTED TO INDICATE THE TRUE CONDITIONS OR ACTUAL QUANTITIES OR DISTRIBUTION OF QUANTITIES OF WORK WHICH WILL BE REQUIRED.

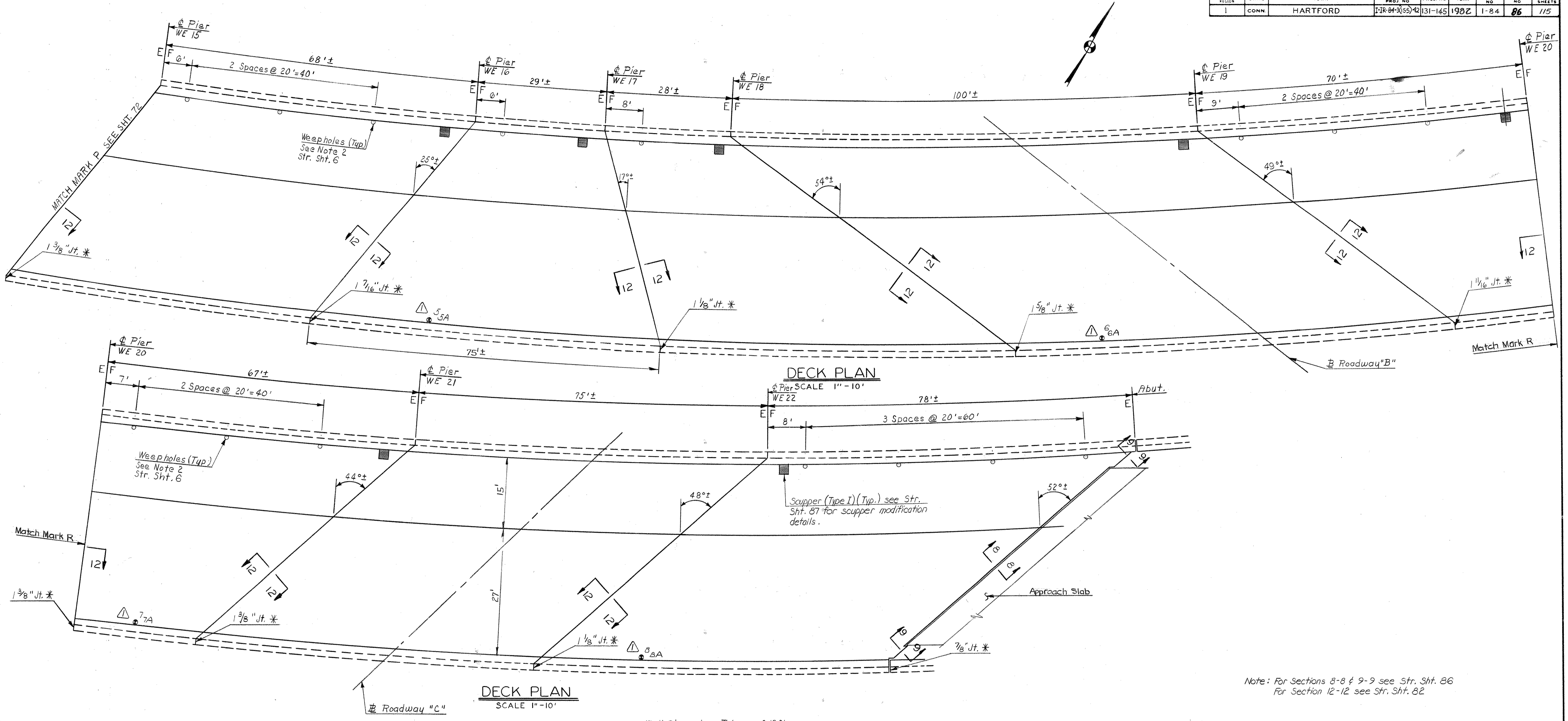

Note: For Sections 8-8 & 9-9 see Str. Sht. 86
 For Section 12-12 see Str. Sht. 82

For Typical Cross Section see Str. Sht. 72

* Jt. Dimensions Taken on 8-12-81.

△ ● Denotes Core Locations

THE INFORMATION, INCLUDING ESTIMATED QUANTITIES OF WORK SHOWN ON THESE SHEETS IS BASED ON LIMITED INVESTIGATIONS BY THE STATE AND IS IN NO WAY WARRANTED TO INDICATE THE TRUE CONDITIONS OR ACTUAL QUANTITIES OR DISTRIBUTION OF QUANTITIES OF WORK WHICH WILL BE REQUIRED.

CONNECTICUT			
DEPARTMENT OF TRANSPORTATION			
SOUTHINGTON - HARTFORD			
INTERSTATE ROUTE 84			
59 STRUCTURES			
DECK REPAIRS			
I-84 E.B. OVER BROAD ST. & RAMPS			
ENGINEER BRIDGE DESIGN UNIT			
DESIGNER J. P. L.	DRAFTER R. G.	CHECKER G. D. B.	
NO. DATE	DESCRIPTION	APPROVED <i>[Signature]</i>	DATE 3/17/82
REVISIONS		STRUCTURE NO. 131-145-3301	BRIDGE LOG NO. 3301
		STRUCTURE SHEET NO. 73 of 87	

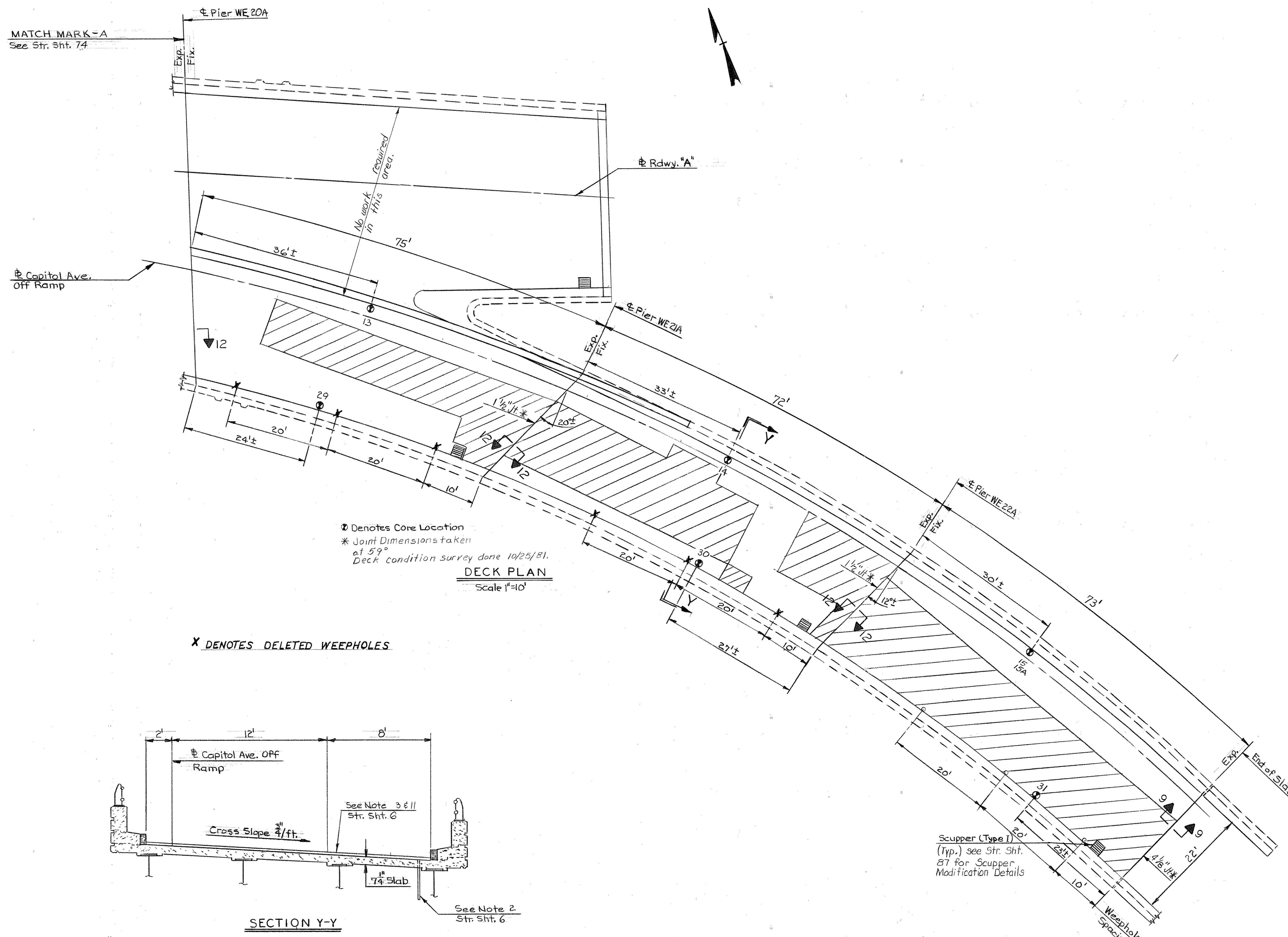

CORE NO.	CHLORIDE CONTENT			
	TOTAL		WATER SOLUBLE	
	% BY WT.	LBS./CY.	% BY WT.	LBS./CY.
(See Note 4 Str. Sht. 6 Date 12-15-81)				
1	0.005	0.196		
2	0.022	0.862		
2A	0.011	0.431		
3	0.012	0.470		
4	0.008	0.314		
5	0.009	0.353		
6	0.007	0.274		
7	0.024	0.941		
7A	0.011	0.431		
8	0.011	0.431		
9	0.006	0.235		
10	0.010	0.392		
11	0.018	0.706		
12	0.017	0.666		
13	0.034	1.333		
14	0.029	1.137		
15	0.101	3.959	0.100	3.920
15A	0.008	0.314		
16	0.033	1.294		
17	0.064	2.391		
18	0.056	2.195		
19	0.062	2.430		
20	0.111	4.351	0.107	4.194
20A	0.030	1.176		
21	0.101	3.959		
22	0.124	4.861		
22A	0.039	1.529		
23	0.093	3.646		
24	0.105	4.116		
25	0.095	3.724		
26	0.020	0.784		
27	0.073	2.862		
28	0.161	6.311	0.154	6.037
28A	0.018	0.706		
29	0.036	1.411		
30	0.020	0.784		
31	0.128	5.018		

NOTE:
For Location of Core No's. 1 thru 5 and 16 thru 20A
See Str. Sht. 71

CONNECTICUT
DEPARTMENT OF TRANSPORTATION
SOUTHINGTON - HARTFORD

INTERSTATE ROUTE 84
59 STRUCTURES
DECK REPAIRS

OFF RAMP OVER BROAD ST, PCRR. & RAMP

ENGINEER Bridge Design Unit
DESIGNER J.R.L. DRAFTER F.T.R. CHECKER G.D.B.

NO.	DATE	DESCRIPTION	APPROVED	DATE
			<i>[Signature]</i>	3/17/82

STRUCTURE NO. 131-145-33.03 BRIDGE LOG NO. 3303 STRUCTURE SHEET NO. 75 OF 87

THE INFORMATION, INCLUDING ESTIMATED QUANTITIES OF WORK SHOWN ON THESE SHEETS IS BASED ON LIMITED INVESTIGATIONS BY THE STATE AND IS IN NO WAY WARRANTED TO INDICATE THE TRUE CONDITIONS OR ACTUAL QUANTITIES OR DISTRIBUTION OF QUANTITIES OF WORK WHICH WILL BE REQUIRED.

BRIDGE NO. 3023

CORE NO.	CHLORIDE CONTENT			
	TOTAL		WATER SOLUBLE	
	% BY WT.	LBS./C.Y.	% BY WT.	LBS./C.Y.
(See Note 4 Str. Sht. 6 Date 12-18-81)				
1	0.128	5.018		
1A	0.020	0.784		
2	0.064	2.509		
3	0.150	5.880	0.147	5.762
3A	0.023	0.902		
4	0.022	0.862		
5	0.032	1.254		
6	0.045	1.764		
7	0.053	2.078		
7A	0.004	0.157		
8	0.049	1.921		
9	0.075	2.940		
10	0.063	2.470		
11	0.058	2.274		
11A	0.003	0.118		

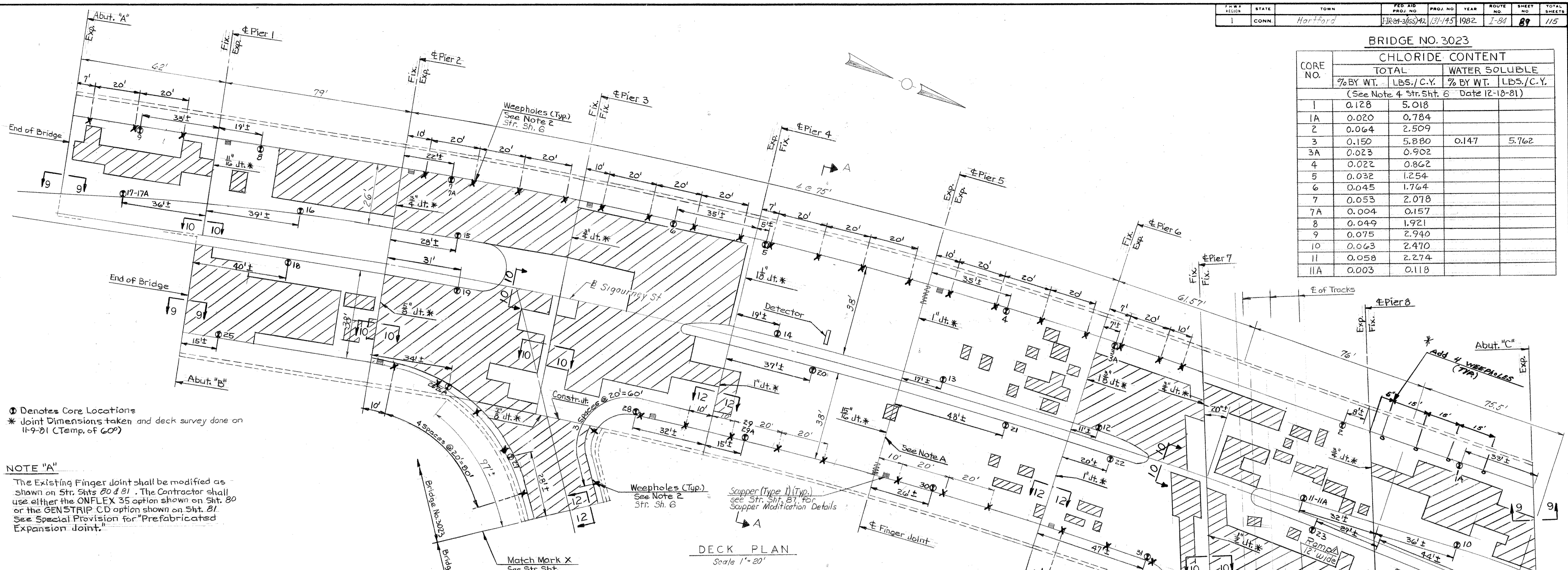

⊙ Denotes Core Locations
 * Joint Dimensions taken and deck survey done on 11-9-81 (Temp. of 60°)

NOTE "A"
 The Existing Finger joint shall be modified as shown on Str. Shts 80 & 81. The Contractor shall use either the ONFLEX 35 option shown on Sht. 80 or the GENSTRIP CD option shown on Sht. 81. See Special Provision for "Prefabricated Expansion Joint."

X DENOTES DELETED WEEPHOLES.

(Chloride Content Continued)

12	0.040	1.568		
13	0.003	0.118		
14	0.003	0.118		
15	0.022	0.862		
16	0.016	0.627		
17	0.024	0.941		
17A	0.004	0.157		
18	0.030	1.176		
19	0.011	0.431		
20	0.004	0.157		
21	0.005	0.196		
22	0.024	0.941		
23	0.005	0.196		
24	0.011	0.431		
25	0.074	2.901		
26	0.258	10.114	0.250	9.800
26A	0.093	3.646		
27	0.062	2.430		
28	0.010	0.392		
29	0.145	5.684	0.137	5.370
29A	0.068	2.666		
30	0.003	0.118		
31	0.049	1.921		
32	0.146	5.723		
32A	0.012	0.470		
33	0.064	2.509		
34	0.005	0.196		

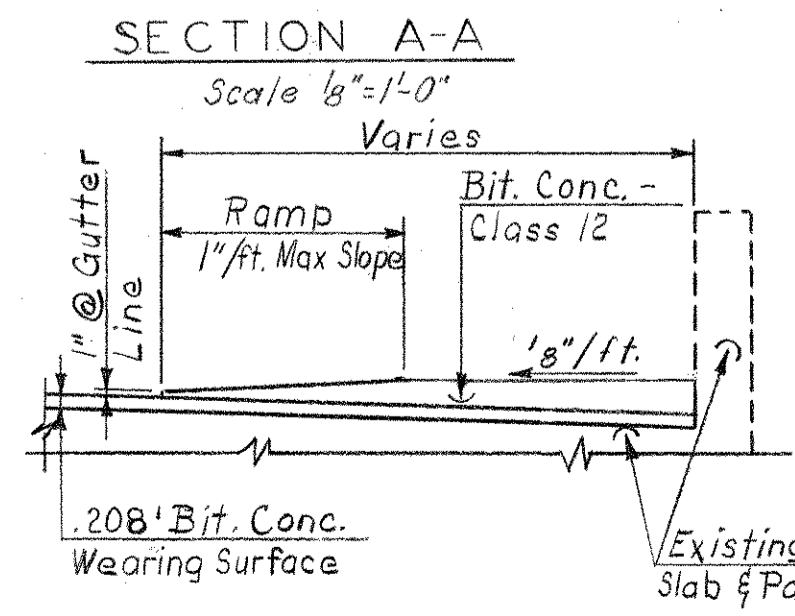
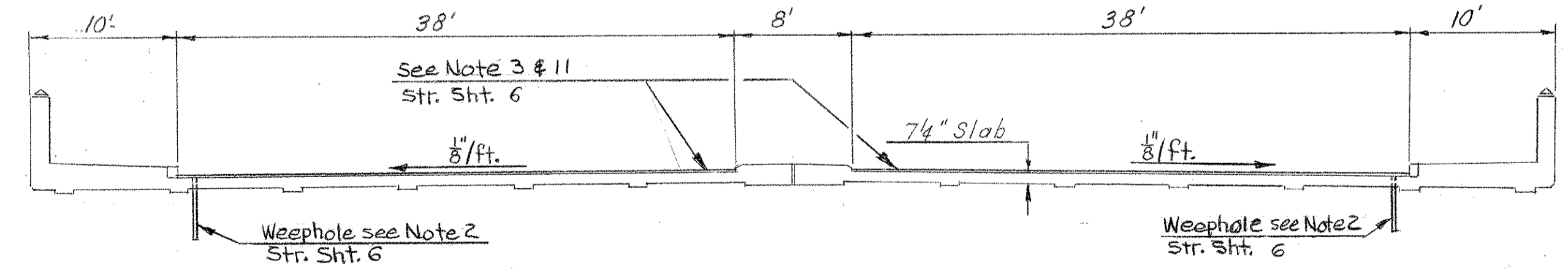

NOTE WELL: Br. No. 3023 shall have "Cool Tar Membrane Waterproofing".

Note: For Sections 9-9 & 10-10 see str. sh. 86
 For Section 12-12 See Section 82.

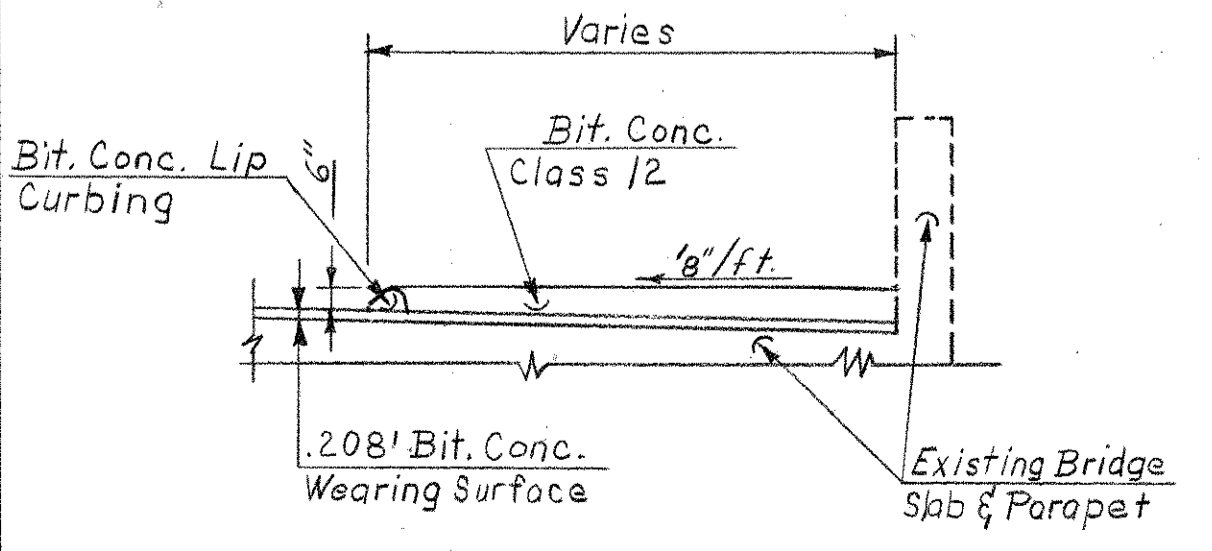

THE INFORMATION, INCLUDING ESTIMATED QUANTITIES OF WORK SHOWN ON THESE SHEETS IS BASED ON LIMITED INVESTIGATIONS BY THE STATE AND IS IN NO WAY WARRANTED TO INDICATE THE TRUE CONDITIONS OR ACTUAL QUANTITIES OR DISTRIBUTION OF QUANTITIES OF WORK WHICH WILL BE REQUIRED.

NO.	DATE	DESCRIPTION	APPROVED	DATE
1	10-82	Add Bit. Conc. Shelf.		

CONNECTICUT
 DEPARTMENT OF TRANSPORTATION
 SOUTHTON - HARTFORD
 INTERSTATE ROUTE 84
 59 STRUCTURES
 DECK REPAIRS
 SIGOURNEY ST. VIADUCT

ENGINEER: BRIDGE DESIGN UNIT
 DESIGNER: J.P.L. DRAFTER: T.S.R. CHECKER: G.D.B.
 APPROVED: [Signature] DATE: 3/17/82
 STRUCTURE NO. 131-145-3023
 BRIDGE LOG NO. 3023 STRUCTURE SHEET NO. 76 of 87

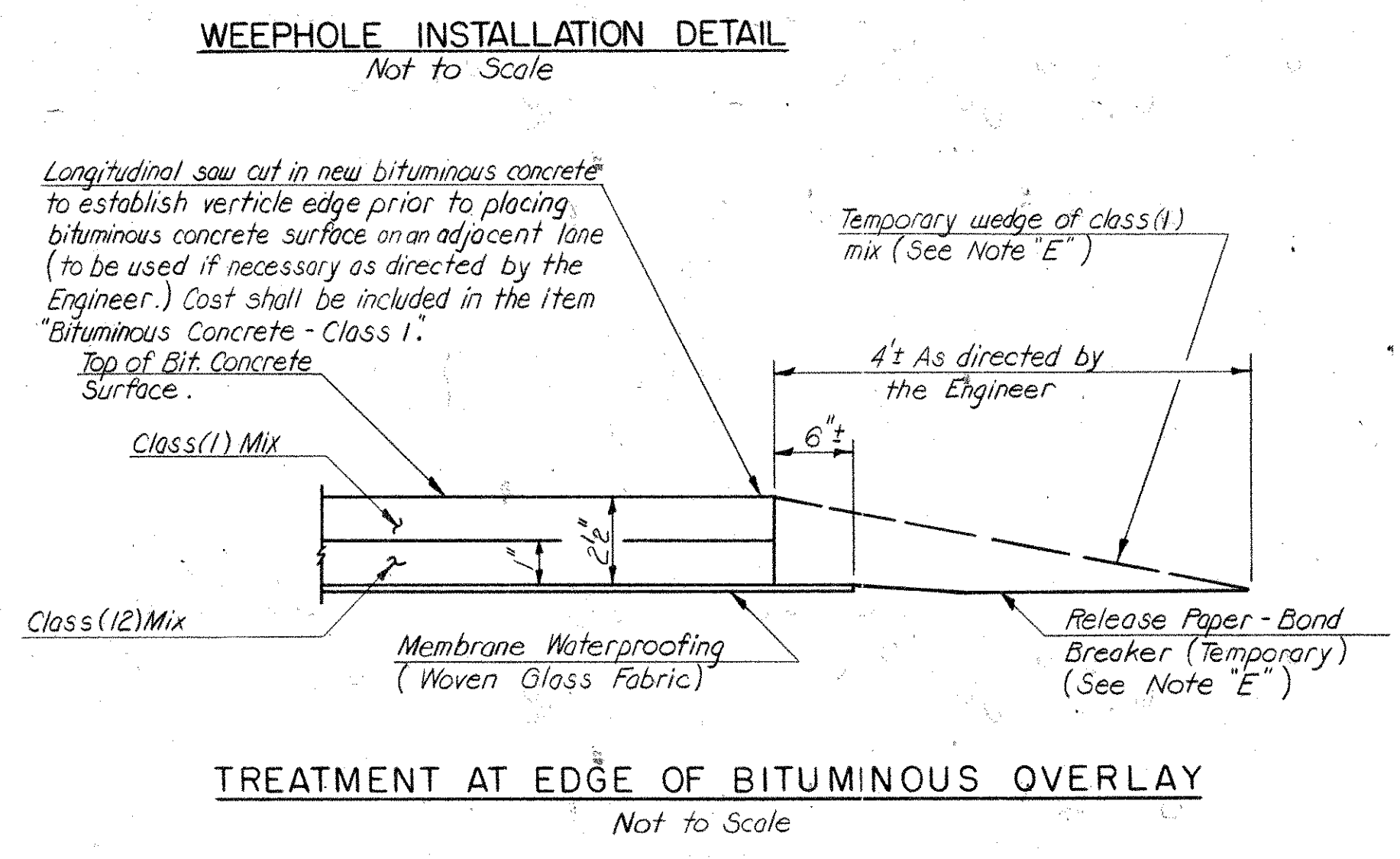
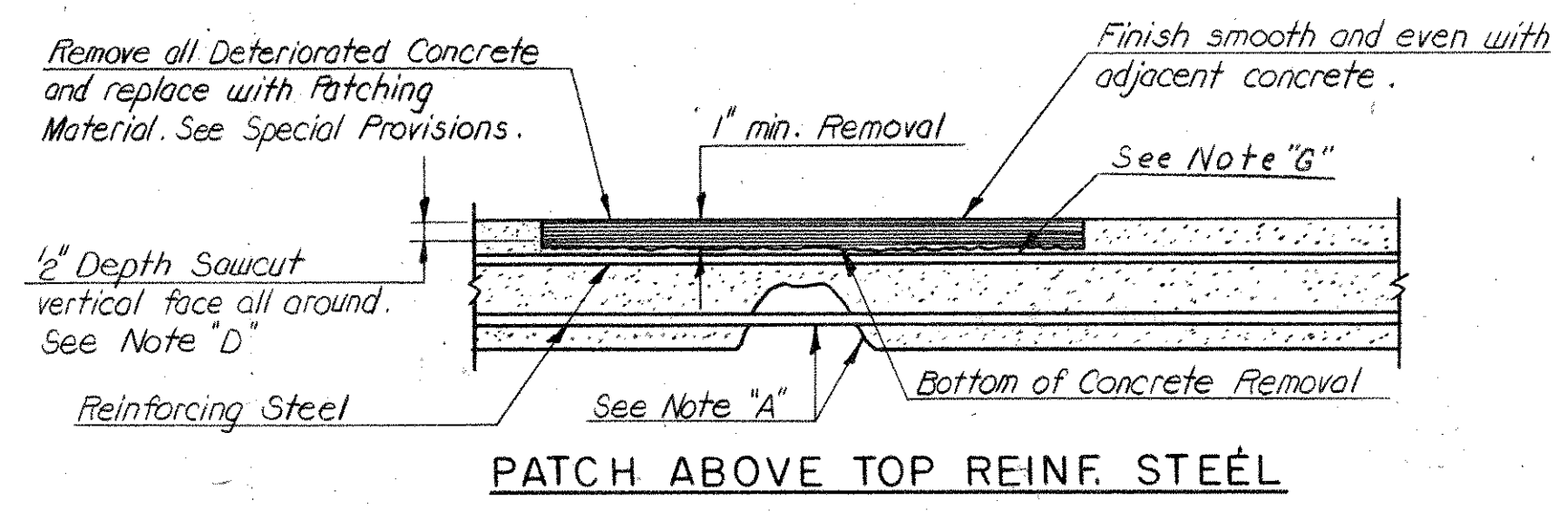
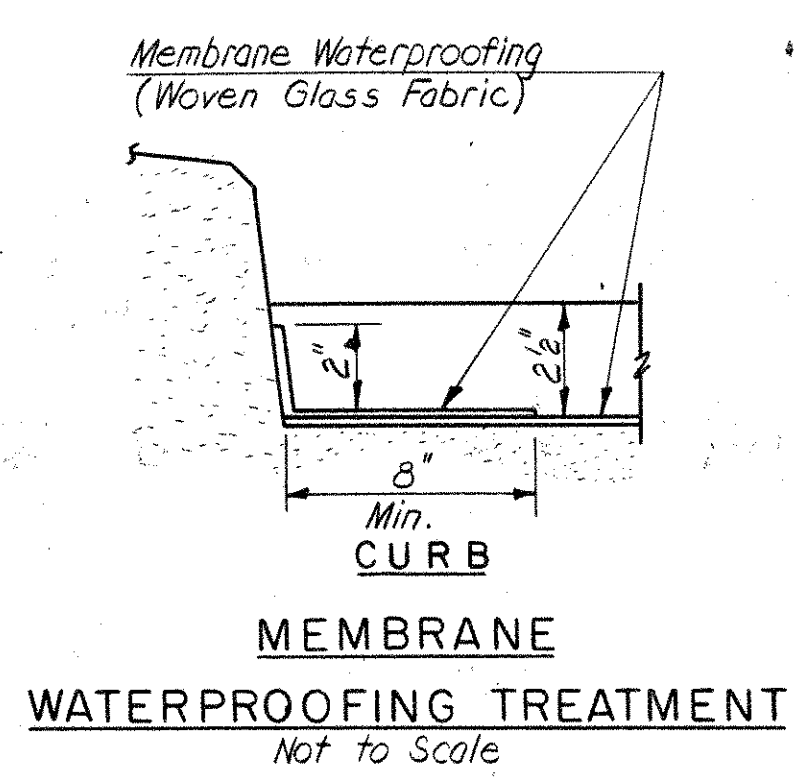
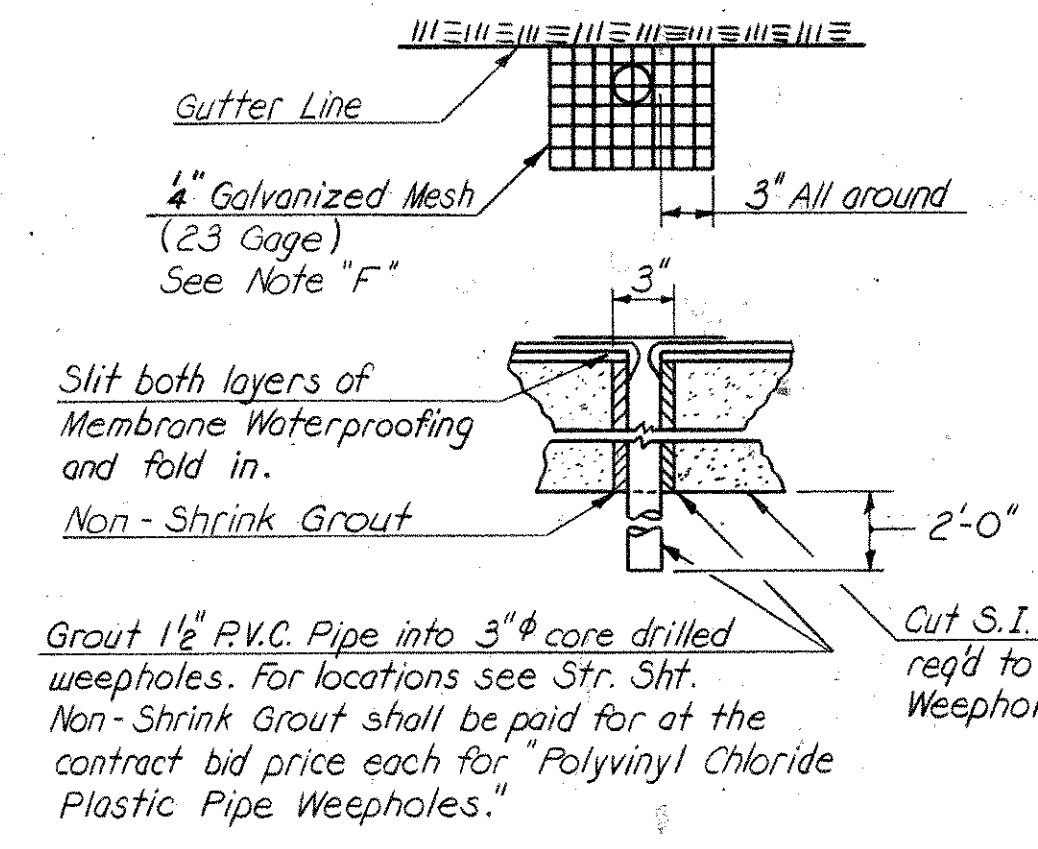
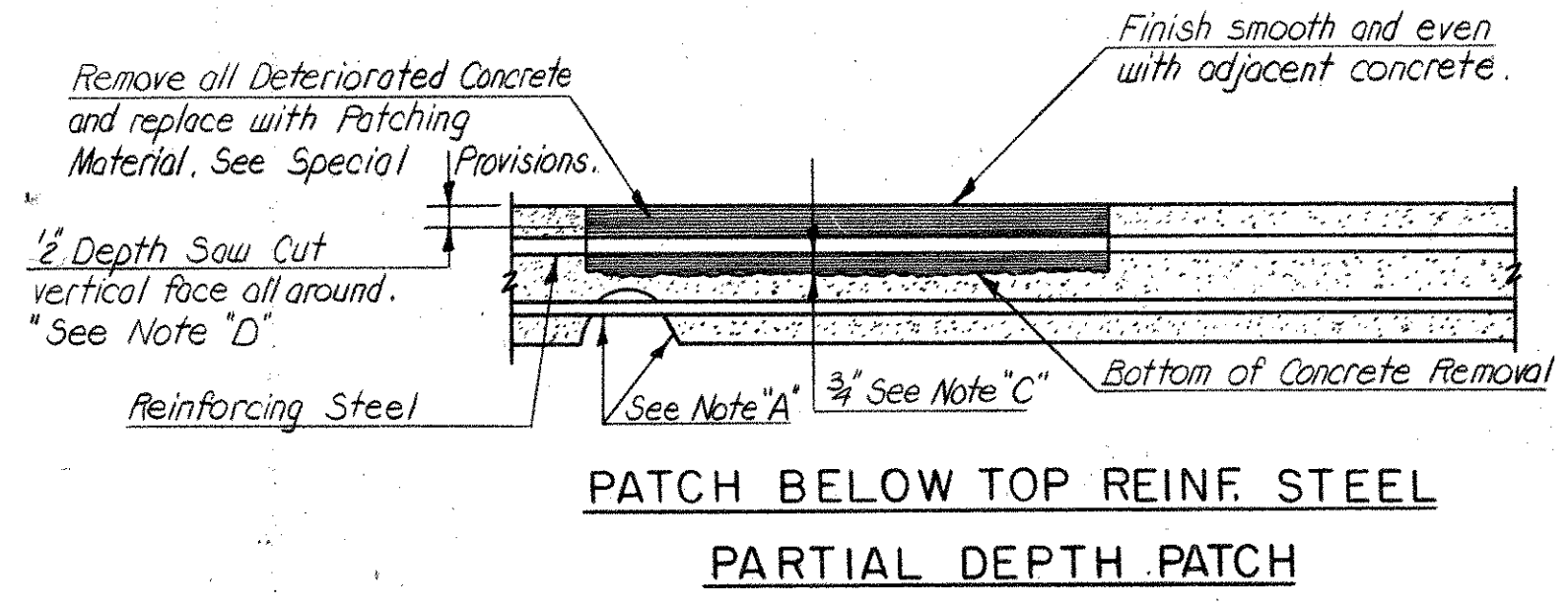
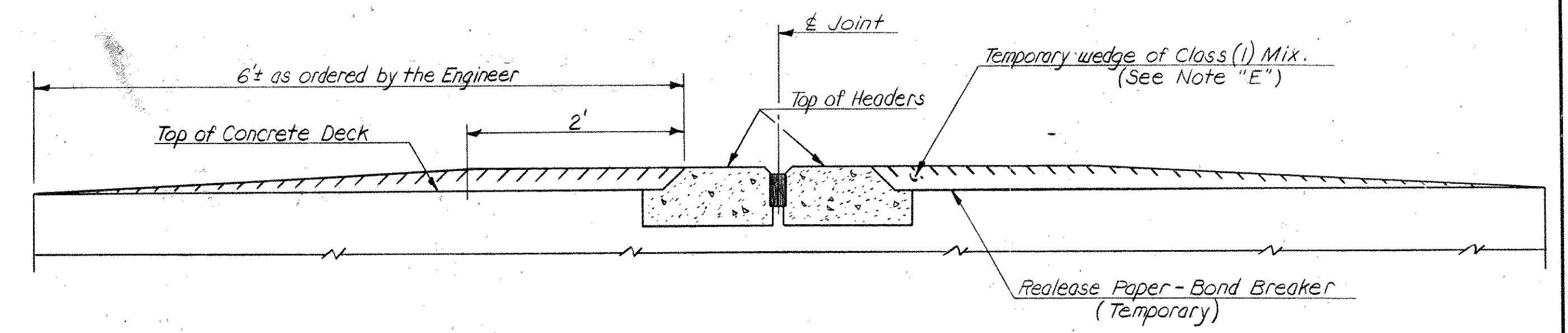
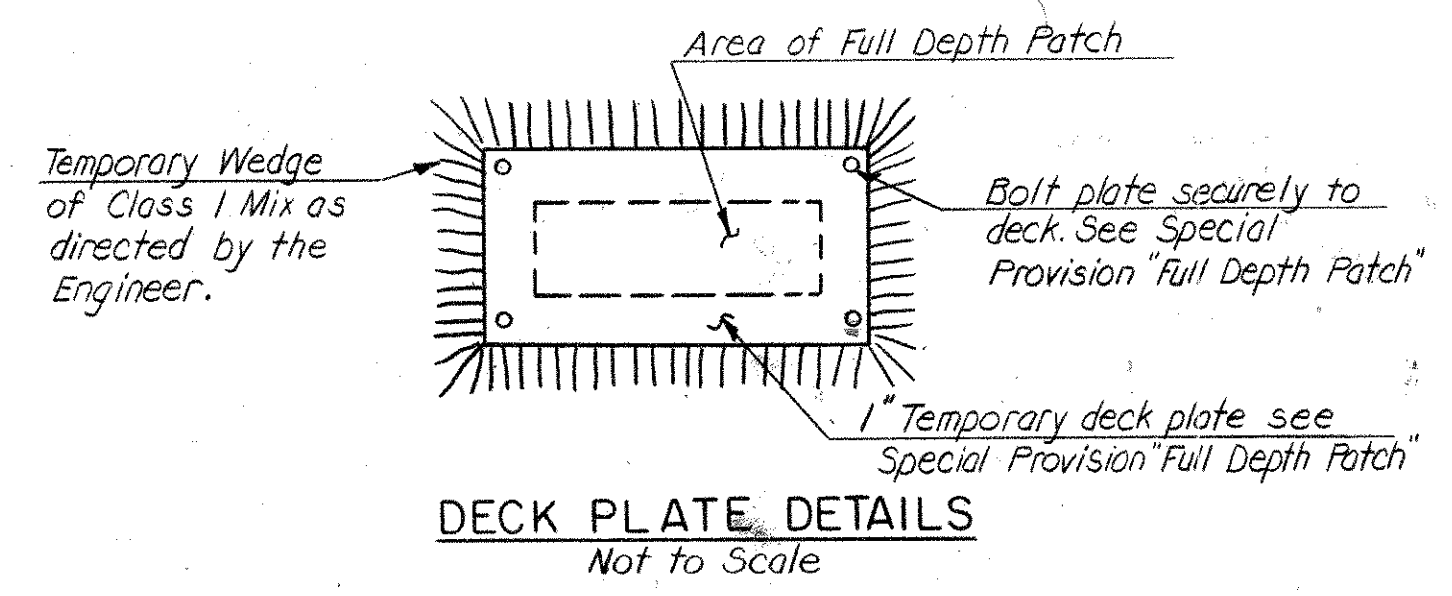
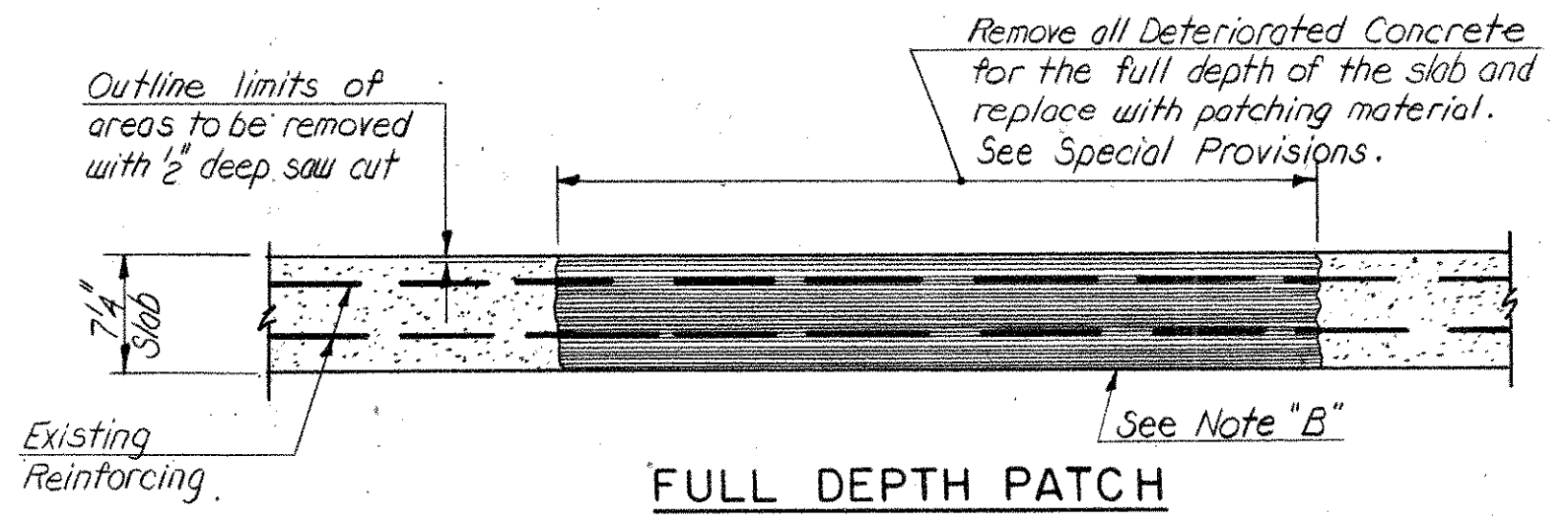

- NOTES**
- For areas to be repaired, see deck plans on str. sht. 7-76 and General Notes str. sh. 6
- Note "A" Areas of pop-outs caused by removal of deteriorated concrete to be coated with epoxy resin system where ordered by the Engineer.
- Note "B" As directed by the Engineer, all voids and honeycomb on this surface shall be filled with the same material as used for "Full Depth Patch" and finished to conform to the surrounding concrete surface.
- Note "C" If after concrete removal the reinforcing steel has at least one half its surface area exposed, the concrete shall be further removed to a depth of 3/4" below the steel.
- Note "D" 1/2" depth sawcut shall be paid for at the contract bid price per C.Y. for "Partial Depth Patch."
- Note "E" Bond breaker and Class (1) Mix shall be placed and removed by the contractor as required by and as directed by the Engineer to maintain and protect traffic. There shall be no direct payment for this work, but the cost shall be considered as included in the general cost of the work.
- Note "F" The cost of furnishing and installing 4" square galvanized mesh shall be included in the contract bid price each for "Polyvinyl Chloride Plastic Pipe Weepholes."
- Note "G" Reinforcing steel partially exposed by the removal of deteriorated concrete to be coated with epoxy resin system where ordered by the Engineer.

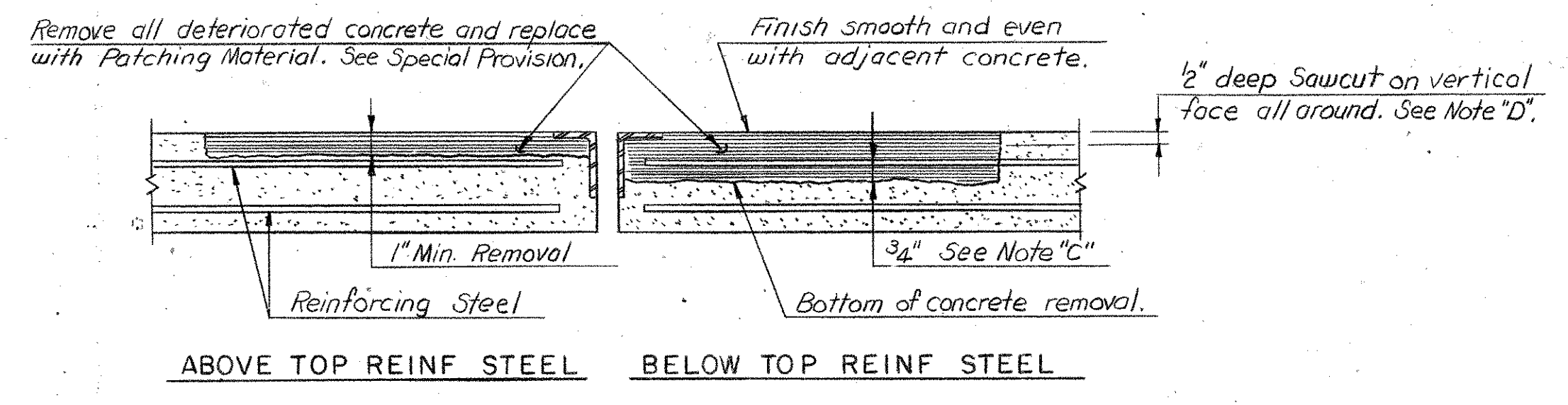
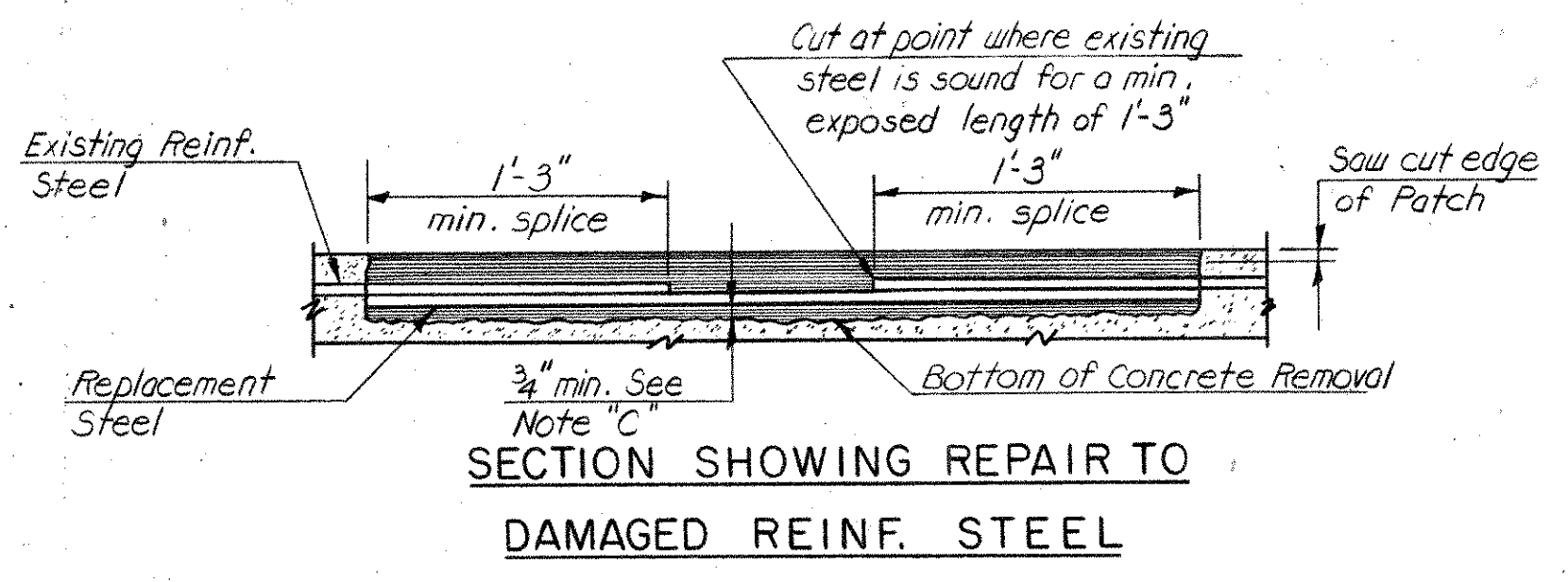
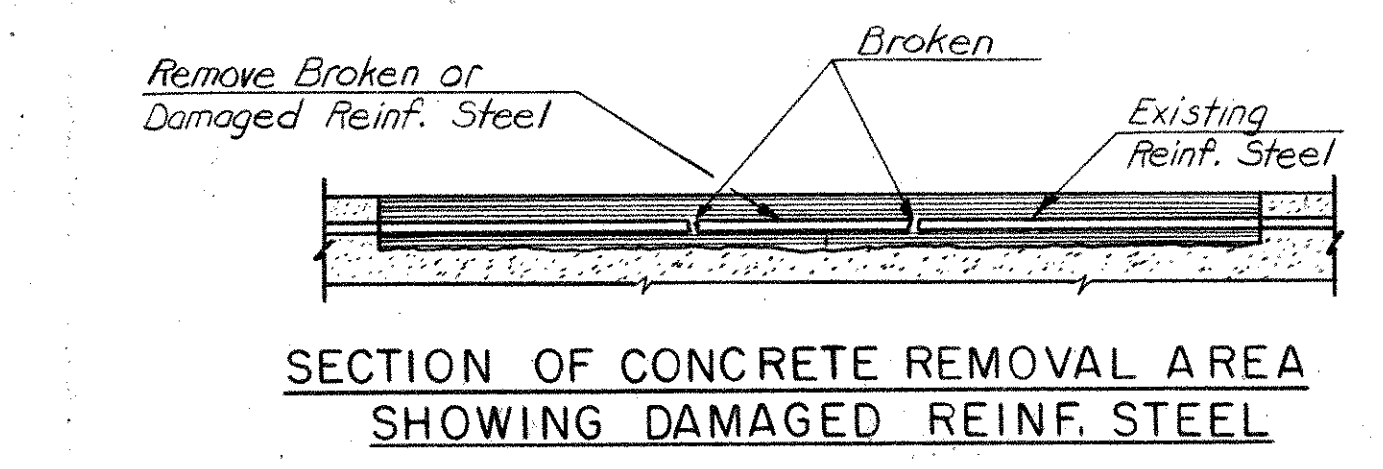

THE INFORMATION, INCLUDING ESTIMATED QUANTITIES OF WORK SHOWN ON THESE SHEETS IS BASED ON LIMITED INVESTIGATIONS BY THE STATE AND IS IN NO WAY WARRANTED TO INDICATE THE TRUE CONDITIONS OR ACTUAL QUANTITIES OR DISTRIBUTION OF QUANTITIES OF WORK WHICH WILL BE REQUIRED.

CONNECTICUT
DEPARTMENT OF TRANSPORTATION
SOUTHINGTON-HARTFORD
INTERSTATE RTE 84
59 STRUCTURES
DECK REPAIRS
DECK REPAIR DETAILS

ENGINEER BRIDGE DESIGN UNIT	
DESIGNER G.J.A.	DRAFTER D.O.T.
CHECKER G.D.B.	
APPROVED <i>[Signature]</i>	DATE 3/17/82
NO. DATE	DESCRIPTION
REVISIONS	STRUCTURE NO.
BRIDGE LOG NO.	STRUCTURE SHEET NO.
	77 of 87

TABLE - E

BRIDGE NUMBER	LOCATION	JOINT TYPE (See Note "A")	E.C.S. (Size) (in.)	JOINT SEAL (Size 50°) (in. * 1/8)
1235	Abut. 1	Joint Seal		1
	Abut. 2	E.C.S.	3	
1236	Abut. 1	Joint Seal		1
	Abut. 2	E.C.S.	3	
1238	Abut. 1	PAVE		
	Abut. 2	E.C.S.	3	
1239	Abut. 1	E.C.S.	3	
	Abut. 2	PAVE		
1246	Abut. 1	Joint Seal		1
	Pier 1-2	Joint Seal		1 1/8
	Abut. 2	Joint Seal		1 1/8
1247	Abut. 1	Joint Seal		1
	Piers 1-2	Joint Seal		1 1/8
	Abut. 2	Joint Seal		1 1/8
648	Abut. 1	Joint Seal		1 1/8
	Piers 1-3	Joint Seal		1 1/8
	Abut. 2	Joint Seal		1 1/8
649	Abut. 1	PAVE		
	Piers 1-3	PAVE		
	Abut. 2	Joint Seal		1 1/8
3170	Abut. 1	Joint Seal		1
	Abut. 2	E.C.S.	3	
3171	Abut. 1	Joint Seal		1
	Abut. 2	E.C.S.	3	
3316	Abut. 1	PAVE		
	Pier 1	PAVE		
	Pier 2	E.C.S.	3	
	Abut. 2	E.C.S.	3	
3307	Abut. 1	PAVE		
	Pier 1	PAVE		
	Pier 2	E.C.S.	3	
	Abut. 2	E.C.S.	3	
3308	Abut. 1	Joint Seal		1 1/8
	Piers 1-2	PAVE		
	Abut. 2	PAVE		
3309	Abut. 1	Joint Seal		1 1/8
	Pier 1	PAVE		
	Abut. 2	Joint Seal		1
3311	Abut. 1	E.C.S.	3	
	Piers 1-5	See Note "B"		
	Abut. 2	E.C.S.	3	
3312	Abut. 1	E.C.S.	3	
	Piers 1-7	See Note "B"		
	Abut. 2	E.C.S.	3	
3313	Abut. 1	E.C.S.	3	
	Piers 1-8	See Note "B"		
	Abut. 2	E.C.S.	2	
3320	Abut. 1	PAVE		
	Pier 1-2	See Note "B"		
	Abut. 2	E.C.S.	3	
3322	Abut. 1	See Note "C"		
	Piers 1, 2 & 4	See Note "D"	2	
	Pier 3	See Note "C"		
	Abut. 2	See Note "C"		
3494	Abuts. 1 & 2	Joint Seal		1 1/8
	Piers 1 & 3	Joint Seal		2 1/8
	Pier 2	Joint Seal		1 1/8
3495	Abuts. 1 & 2	Joint Seal		1 1/8
	Piers 1 & 3	Joint Seal		2 1/8
	Pier 2	Joint Seal		1 1/8
3499	Abut. 1	PAVE		
	Pier 1	PAVE		
	Pier 2	Joint Seal		1 1/8
	Abut. 2	Joint Seal		1 1/8

TABLE - E

BRIDGE NUMBER	LOCATION	JOINT TYPE (See Note "A")	E.C.S. (Size) (in.)	JOINT SEAL (Size 50°) (in. * 1/8)
3759	Abut. 1	E.C.S.	4	
	Abut. 2	Joint Seal		1
3760	Abut. 1	E.C.S.	3	
	Abut. 2	Joint Seal		1
3496	Abut. 1	PAVE		1 7/8
	Pier 1	Joint Seal		2 1/2
	Pier 2	Joint Seal		1 7/8
	Abut. 2	Joint Seal		1 1/8
3497	Abut. 1	Joint Seal		1 5/8
	Pier 1	Joint Seal		2 1/8
	Pier 2	Joint Seal		1 5/8
	Abut. 2	Joint Seal		1 5/8
3485	Abut. 1	E.C.S.	2	
	Pier 1	PAVE		
	Pier 2	PAVE		
	Abut. 2	E.C.S.	2	
3486	Abut. 1	E.C.S.	2	
	Pier 1	PAVE		
	Pier 2	PAVE		
	Abut. 2	E.C.S.	2	
1743 EB	Abut. 1	E.C.S.	2	
	Pier 1	PAVE		
	Abut. 2	E.C.S.	2	
1743 WB	Abut. 1	PAVE		
	Pier 1	PAVE		
	Abut. 2	PAVE		
1744	Abut. 1	E.C.S.	2	
	Pier 1	PAVE		
	Pier 2	PAVE		
	Abut. 2	E.C.S.	2	
1745	Abut. 1	PAVE		
	Pier 1	PAVE		
	Pier 2	PAVE		
	Abut. 2	E.C.S.	2	
1749	Abut. 1	Joint Seal		1 5/8
	Abut. 2	Joint Seal		1
1751	Abut. 1	E.C.S.	3	
	Pier 1	PAVE		
	Pier 2	PAVE		
	Pier 3	E.C.S.	3	
	Pier 4	PAVE		
	Abut. 2	E.C.S.	3	
1752	Abut. 1	Joint Seal		1 5/8
	Pier 1	Joint Seal		2 1/8
	Pier 2	Joint Seal		2 1/8
	Pier 3	Joint Seal		2 1/8
	Pier 4	Joint Seal		2 1/8
	Pier 5	Joint Seal		2 1/8
	Pier 6	PAVE		
	Abut. 2	Joint Seal		2 1/8
1753	Abut. 1	PAVE		
	Pier 1	PAVE		
	Pier 2	Joint Seal		2 1/8
	Pier 3	Joint Seal		2 1/8
	Pier 4	Joint Seal		2 1/8
	Pier 5	Joint Seal		2 1/8
	Abut. 2	PAVE		
1754	Abut. 1	PAVE		
	Pier 1	PAVE		
	Pier 2	E.C.S.	3	
	Pier 3	E.C.S.	3	
	Pier 4	E.C.S.	3	
	Abut. 2	PAVE		

TABLE - E

BRIDGE NUMBER	LOCATION	JOINT TYPE (See Note "A")	E.C.S. (Size) (in.)	JOINT SEAL (Size 50°) (in. * 1/8)
3367	Abut. 1	E.C.S.	3	
	Piers 1-13	E.C.S.	3	
	Pier 14	E.C.S.	4	
	Pier 15	E.C.S.	Note "E"	
	Pier 16	E.C.S.	Note "E"	
	Pier 17	PAVE		
	Abut. 2	E.C.S.	2	
3368	Abut. 1	E.C.S.	3	
	Piers 1-9	E.C.S.	3	
	Pier 10	E.C.S.	2	
	Abut. 2	E.C.S.	2	
3369	Abut. 1	E.C.S.	2	
	Piers 1-8	E.C.S.	2	
	Pier 9	PAVE		
	Piers 10-18	E.C.S.	2	
	Pier 19	PAVE		
	Abut. 2	E.C.S.	2	
3370	Abut. 1	E.C.S.	2	
	Pier 1	E.C.S.	2	
	Pier 2	PAVE		
	Pier 2	PAVE		
	Abut. 2	E.C.S.	2	
3400A	Abut. 1	PAVE		
	Pier 1	PAVE		
	Pier 2	E.C.S.	3	
	Pier 3	PAVE		
3400B	Pier 4	PAVE		
	Pier 5	PAVE		
	Pier 6	PAVE		
	Abut. 2	E.C.S.	2	
3400C	Pier 3	E.C.S.	3	
	Pier 4A	PAVE		
	Piers 5A-10A	E.C.S.	3	
	Pier 11A	E.C.S.	4	
	Pier 12A	E.C.S.	2	
	Pier 13A	E.C.S.	2	
	Pier 14A	See Note "F"		
	Pier 15A	E.C.S.	2	
	Piers 16A-18A	E.C.S.	3	
3400D	Piers 19A-23A	E.C.S.	3	
	Pier 24A	E.C.S.	2	
	Abut. 3	E.C.S.	3	
3399A	Abut. 1	E.C.S.	2	
	Pier 1	E.C.S.	2	
	Pier 2	E.C.S.	3	
3399B	Piers 3-7	E.C.S.	3	
	Abut. 2	E.C.S.	2	
3399C	Pier 4	E.C.S.	3	
	Piers 5A-13A	E.C.S.	3	
	Piers 14A-16A	E.C.S.	2	
3399D	Pier 17A	Joint Seal		2 1/2
	Pier 18A	Joint Seal		2 1/8
	Piers 19A-23A	E.C.S.	3	
	Abut. 3	E.C.S.	3	
3401A/B	Abut. "C"	E.C.S.	2	
	Pier NE 1	E.C.S.	2	
	Piers NE 2-NE 14	E.C.S.	3	
	Piers NE 15-NE 16	E.C.S.	2	
	Piers NE 17-NE 20	E.C.S.	3	
3402A	Abut. 1	E.C.S.	2	
	Pier 1	E.C.S.	3	
	Pier 2	E.C.S.	4	
	Piers 3-5	E.C.S.	3	
	Pier 6	See Note "F"		

TABLE - E

BRIDGE NUMBER	LOCATION	JOINT TYPE (See Note "A")	E.C.S. (Size) (in.)	JOINT SEAL (Size 50°) (in. * 1/8)
3402B	Piers 1-9	E.C.S.	3	
	Abut. 2	E.C.S.	3	
3160A	Abut. "B"	PAVE		
	Piers SE 1-SE 5	E.C.S.	2	
	Piers ML 1- ML 10	E.C.S.	2	
	Pier ML 11	See Note "G"		
	Pier ML 12	PAVE		
	Expansion Link	See Note "G"		
	Fixed Link	E.C.S.	2	
	Pier ML 13	PAVE		
	Pier ML 14	See Note "G"		
	Piers ML 15-ML 31	E.C.S.	2	
	Piers WE 1-WE 8	E.C.S.	2	
3160B	Abut. "A"	PAVE		
	Piers ES 1-ES 4	E.C.S.	2	
	Piers ML 1- ML 10	E.C.S.	2	
	Pier ML 11	See Note "G"		
	Pier ML 12	PAVE		
	Expansion Link	See Note "B"		
	Fixed Link	E.C.S.	2	
	Pier ML 13	PAVE		
	Pier ML 14	See Note "H"		
	Piers ML 15-ML 31	E.C.S.	2	
	Piers EW 1-EW 8	E.C.S.	2	
3160C	Pier EBR 1	E.C.S.	2	
	Pier EBR 2	See Note "G"		
	Pier EBR 3	E.C.S.	2	
	Pier EBR 4	E.C.S.	2	
	Pier EBR 5	E.C.S.	2	
	Pier EBR 6	E.C.S.	2	
	Pier EBR 7	E.C.S.	2	
3160D	Pier WBR 1	E.C.S.	2	
	Pier WBR 2	See Note "B"		
	Pier WBR 3	E.C.S.	2	
	Pier WBR 4	E.C.S.	2	
	Pier WBR 5	E.C.S.	2	
3301	Pier WE 9	PAVE		
	Pier WE 10	E.C.S.	2	
	Pier WE 11	E.C.S.	2	
	Pier WE 12	E.C.S.	2	
	Pier WE 13	E.C.S.	3	
	Pier WE 14	E.C.S.	2	
	Pier WE 15	E.C.S.	2	
	Pier WE 16	E.C.S.	2	
	Pier WE 17	E.C.S.	2	
	Pier WE 18	Joint Seal		1 1/8
	Pier WE 19	Joint Seal		2 1/8
	Pier WE 20	E.C.S.	2	1 1/8
	Pier WE 21	Joint Seal		1 1/8
	Pier WE 22	Joint Seal		1 1/8
	Abut.	PAVE		

TABLE - E

BRIDGE NUMBER	LOCATION	JOINT TYPE (See Note "A")	E.C.S. (Size) (in.)	JOINT SEAL (Size 50°) (in. * 1/8)
3303	Pier WE 9A	E.C.S.	2	
	Pier WE 10A	PAVE		
	Pier WE 11A	E.C.S.	2	
	Pier WE 12A	E.C.S.	2	
	Pier WE 13A	E.C.S.	2	
	Pier WE 14A	E.C.S.	2	
	Pier WE 15A	E.C.S.	2	
	Pier WE 16A	Joint Seal		1 1/8
	Pier WE 17A	Joint Seal		1 1/8
	Pier WE 18A	See Note "F"		
	Pier WE 19A	E.C.S.	2	
	Pier WE 20A	E.C.S.	2	
	Pier WE 21A	E.C.S.	2	
	Pier WE 22A	E.C.S.	2	
	Abut.	E.C.S.	2	
3023	Abut. "A"	PAVE		
	Abut. "B"	PAVE		
	Pier 1	PAVE		
	Pier 2	PAVE		
	Pier 3	PAVE		
	Pier 4	E.C.S.	3	
	Pier 5	See Note "G"		
	Pier 6	E.C.S.	3	
	Pier 7	PAVE		
	Pier 8	PAVE		
	Abut. "C"	PAVE		

NOTES:

A: Joint type abbreviations
 E.C.S. = Elastomeric Compression Seal.
 Joint Seal = Joint Seal (Type A).
 PAVE = Locations to be membraned and overlaid.

B: See "Modification of Armored Compression Seals" Str. Sht.

C: No work required.

D: New headers and E.C.S. required.

E: At Fixed bearing use 3" E.C.S. At Expansion bearing use 4" E.C.S.

F: See "Modification to Finger Joints", Str. Sht.

G: Existing finger joints shall be modified as shown on Str. Shts. 80 and 81. The Contractor shall use either the ONFLEX 35 option shown on Str. Sht. 80 or the GENSTRIP CD option shown on Str. Sht. 81.

H: Existing WABOFLEX joint to be left in place, repaired as required, and protected while exposed.

CONNECTICUT
 DEPARTMENT OF TRANSPORTATION
 SOUTHLINGTON - HARTFORD

INTERSTATE ROUTE 84
 59 STRUCTURES
 DECK REPAIRS

TABLE - E

ENGINEER BRIDGE DESIGN UNIT
 DESIGNER G.J.A. DRAFTSMAN G.J.A. CHECKER G.D.B.
 NO. DATE DESCRIPTION APPROVED *[Signature]* DATE 3/17/82
 REVISIONS STRUCTURE NO. BRIDGE LOG NO. STRUCTURE SHEET NO.
 78 of 87

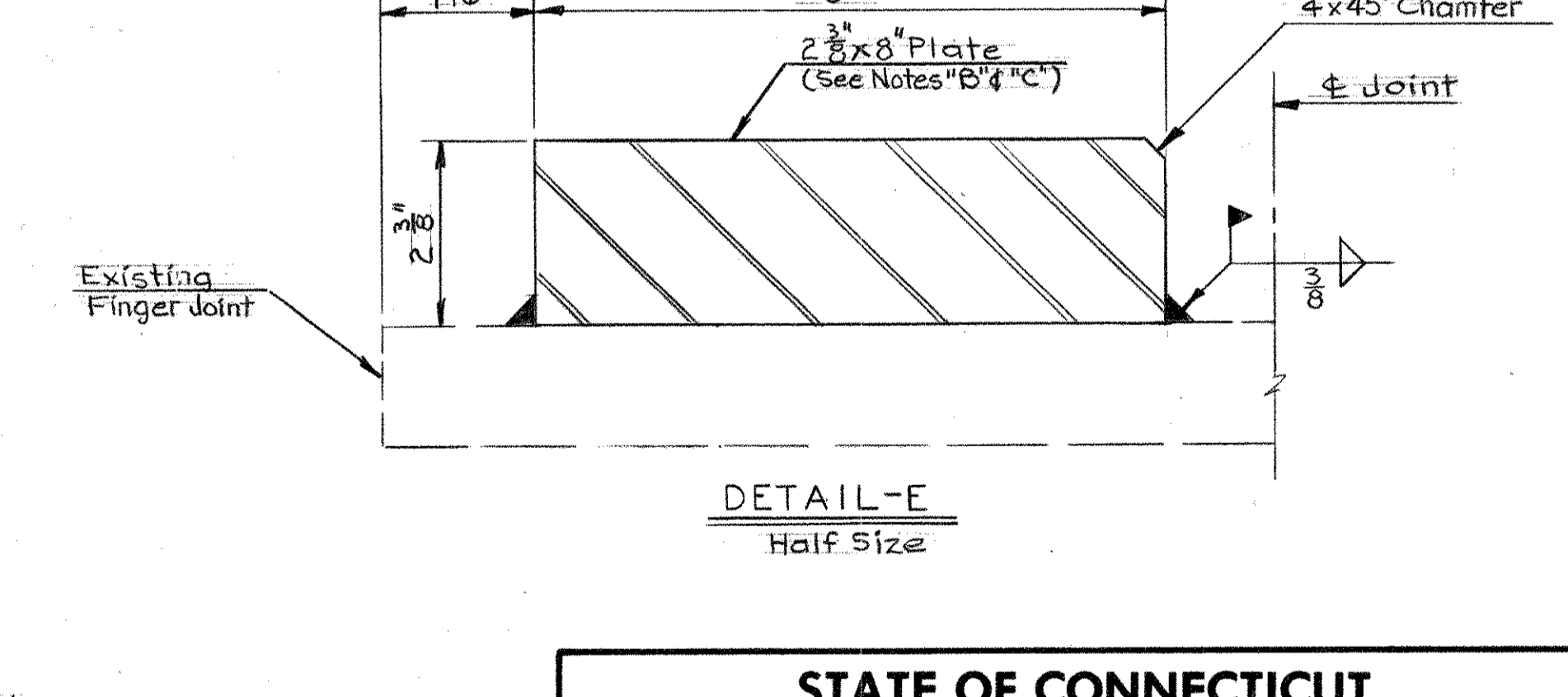
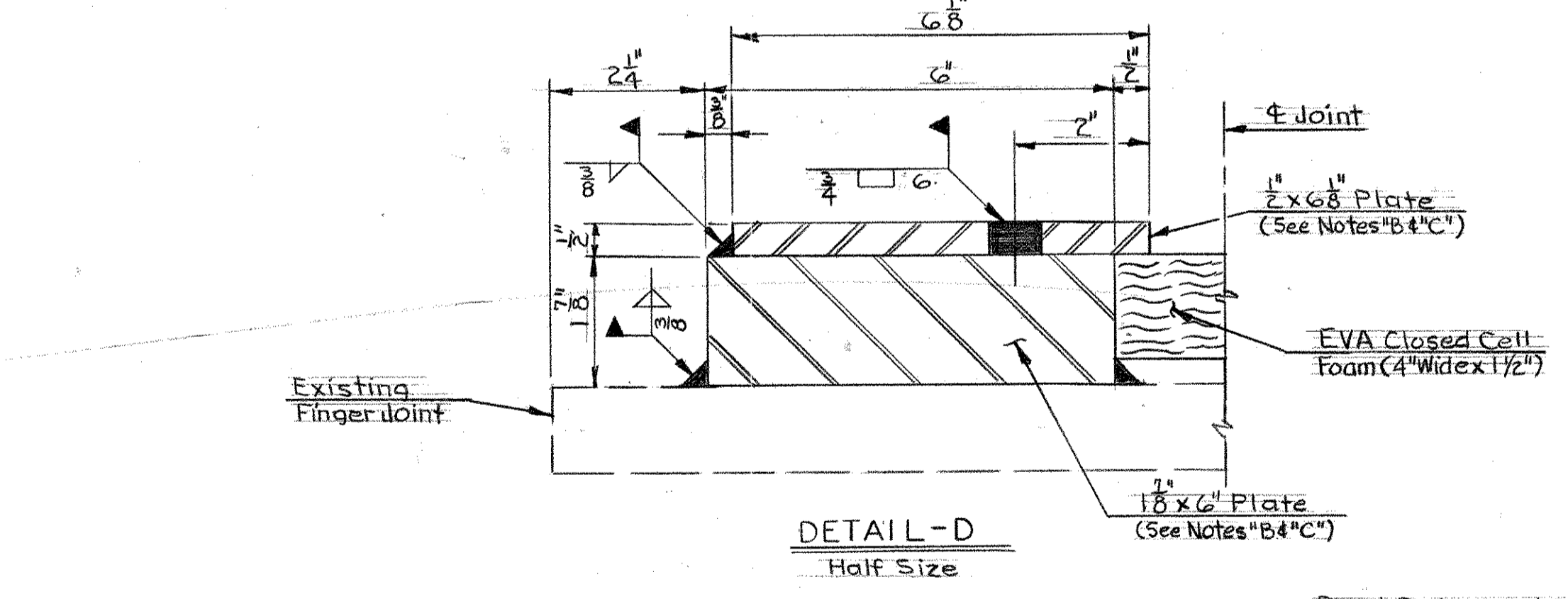
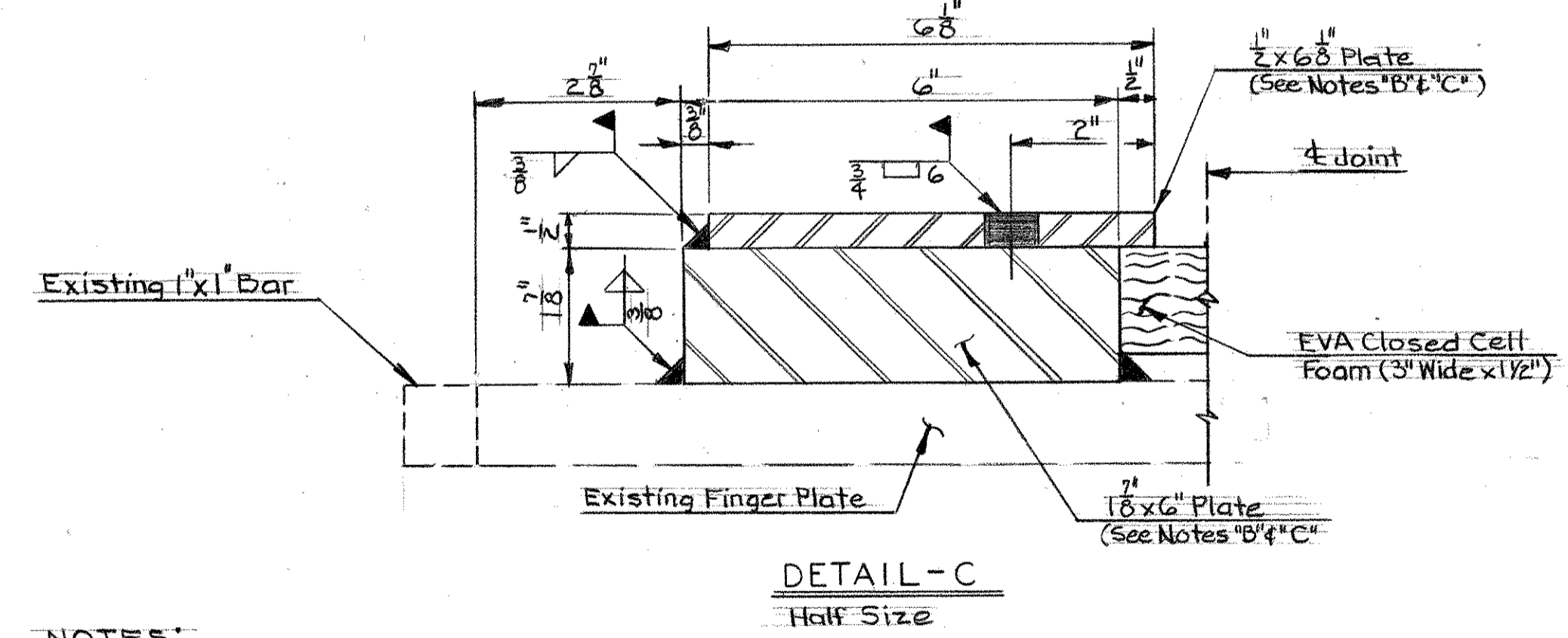
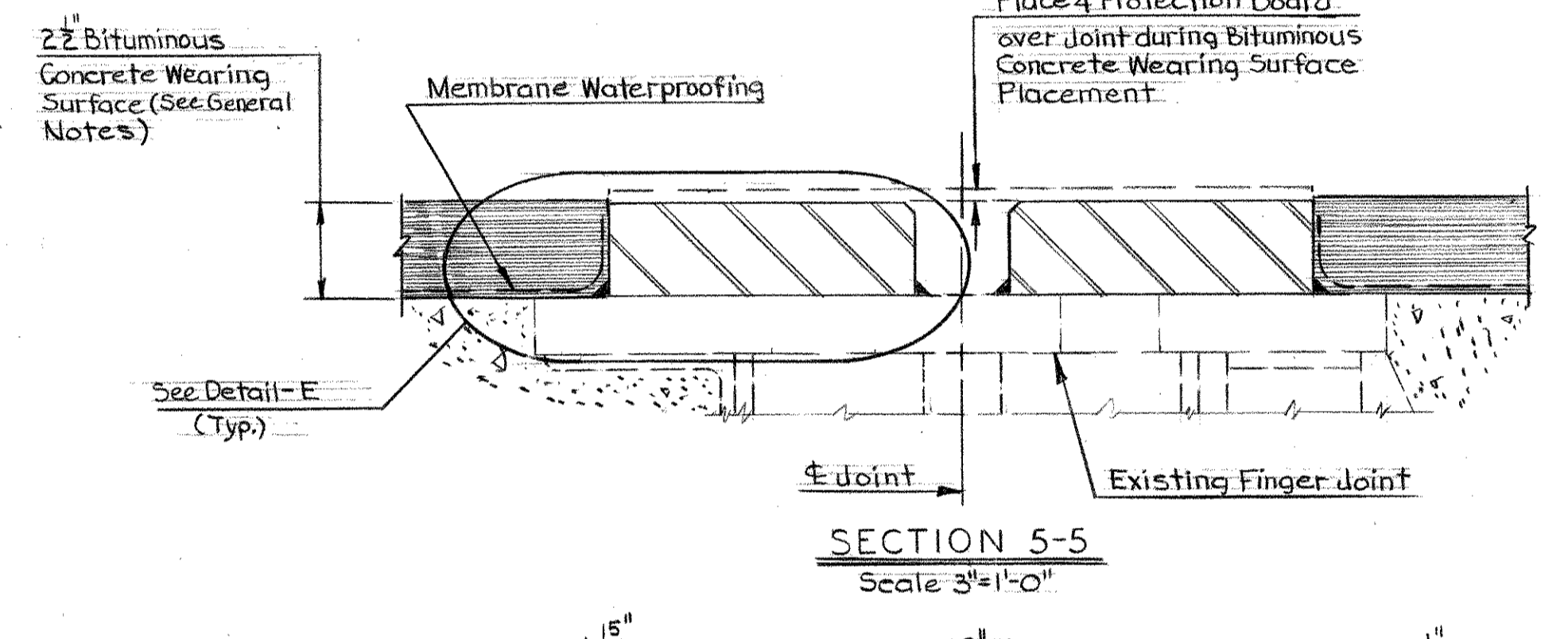
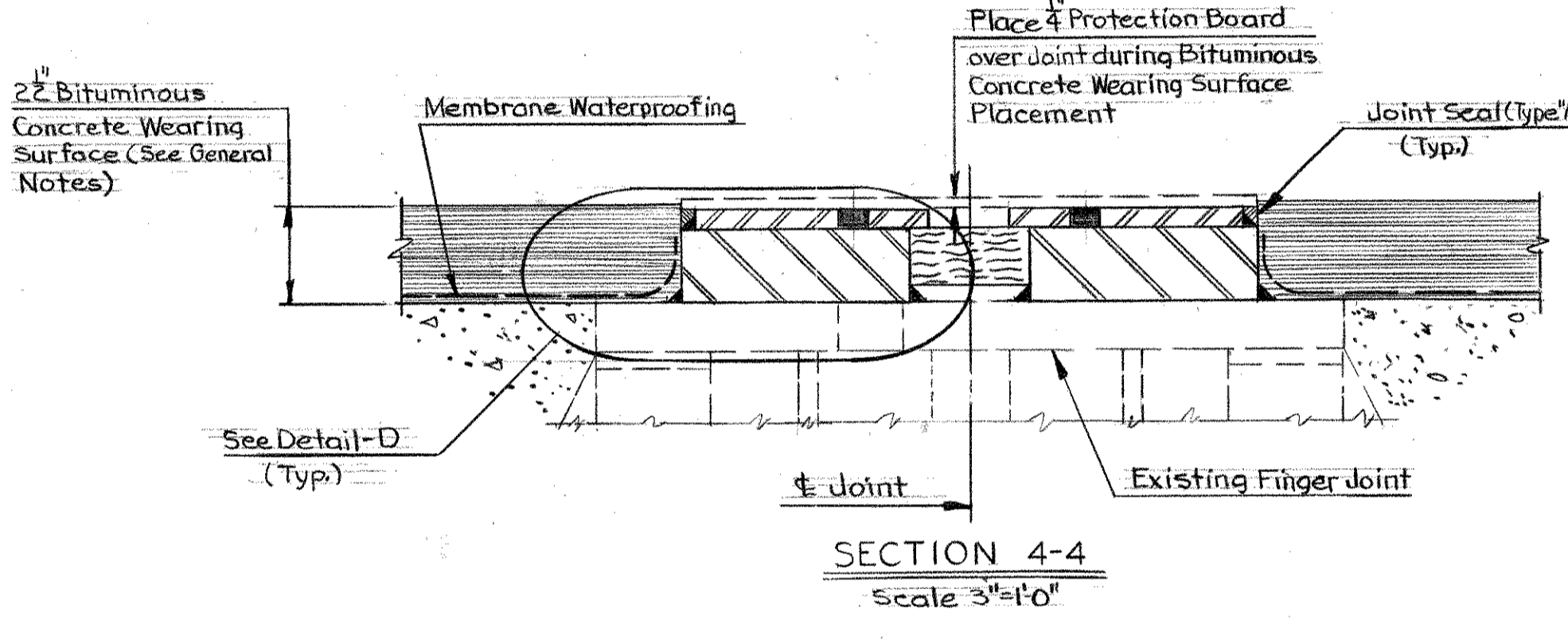
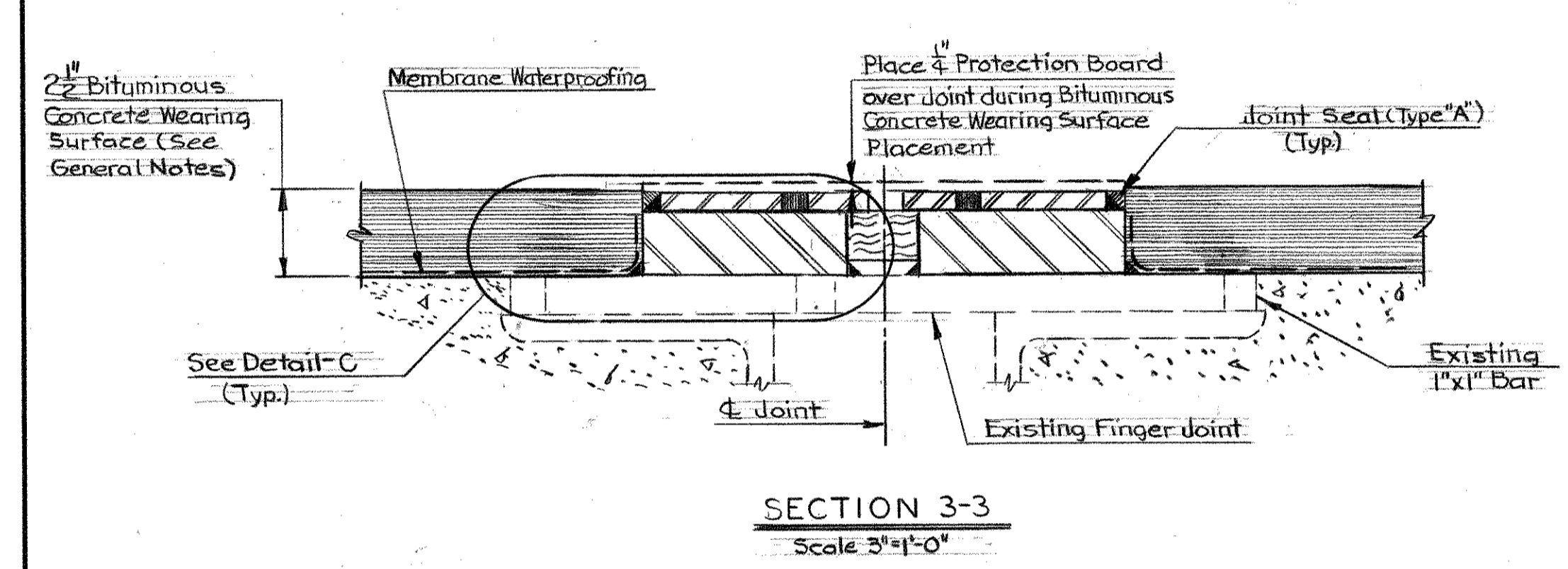
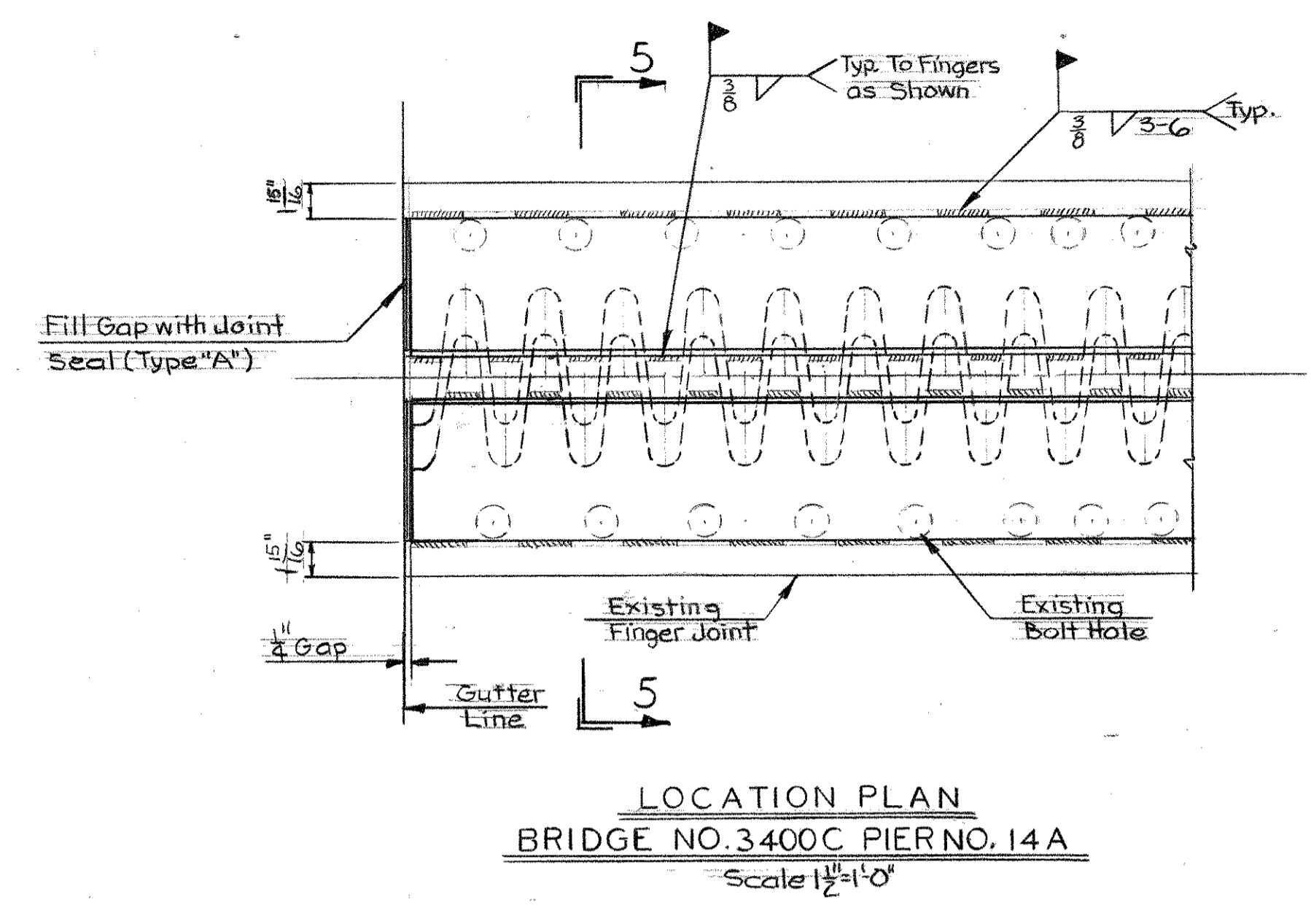
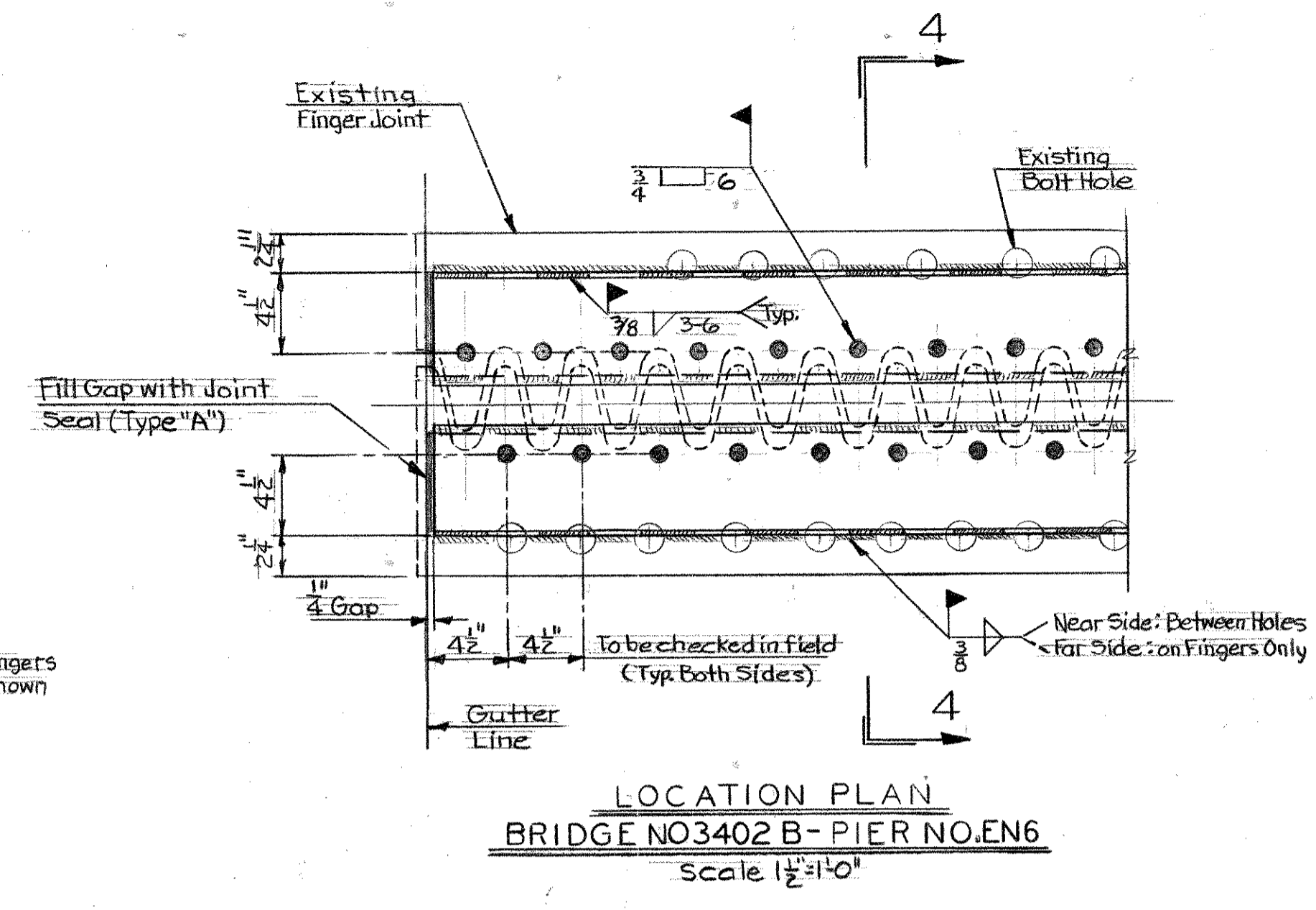
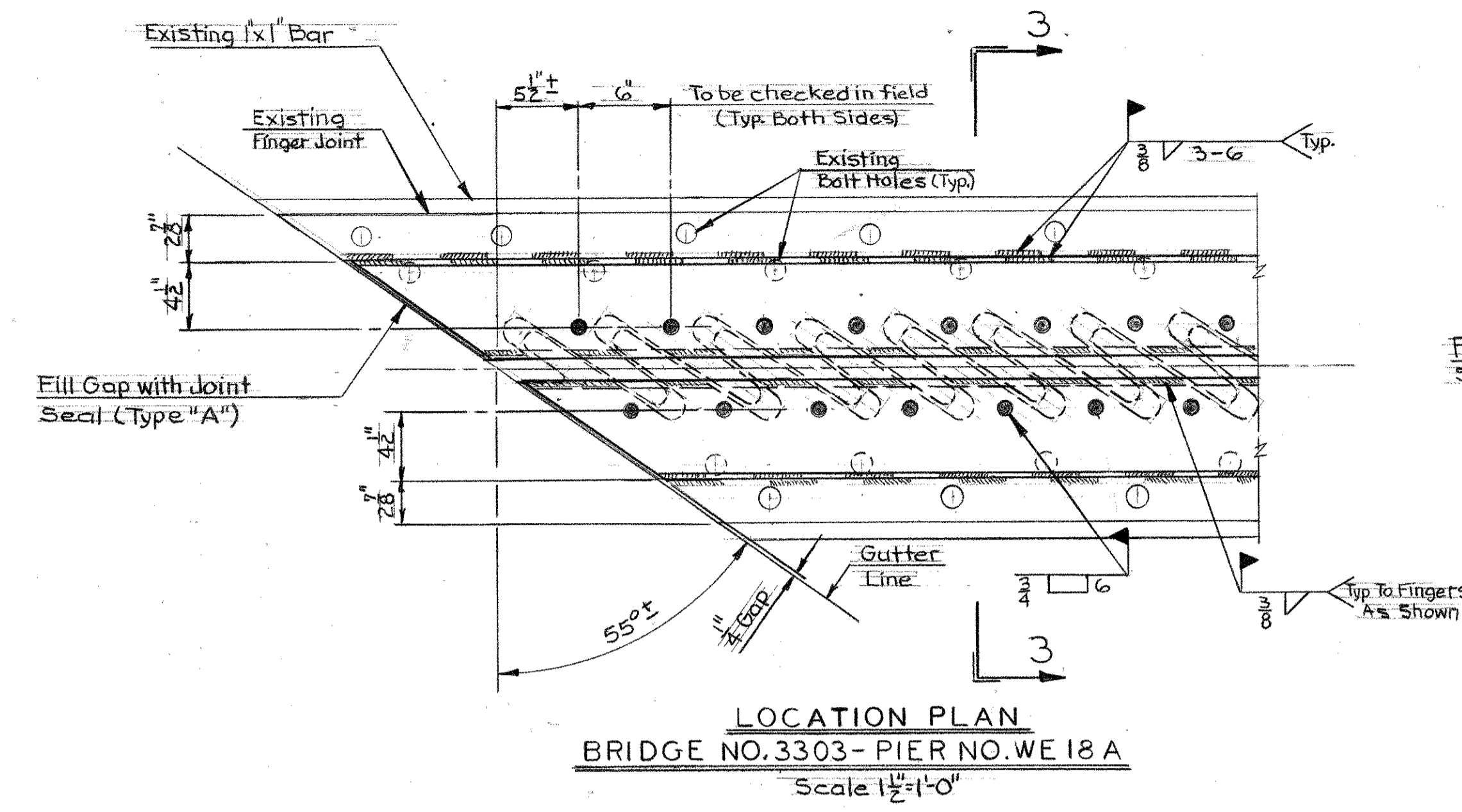

NOTES:
 A: All data shown in Table-C and information showing existing conditions was taken from the original contract plans and shop plans. These plans are available to the Contractor at the request of the Engineer. The contractor shall verify all data before fabrication of the new joint components.
 B: The cost of furnishing and installing plates on Structure No. 3400 C shall be included in the item "Modify Finger Joint (Str. No. 3400C)". The cost of furnishing and installing plates and EVA Closed Cell Foam on Structure No. 3303 and 3402 A shall be included in the item "Prefabricated Expansion Joint (EVA Foam)".
 C: Plates shall be installed in continuous lengths wherever possible, joints shall be held to a minimum, consistent with the requirements for "Maintenance and Protection of Traffic" and field conditions. EVA Closed Cell Foam shall be installed in lengths consistent with the above requirements and the special provisions.
 D: All Structural Steel shall be ASTM A588.
 E: Temporary protection of joints shall be provided as shown on "Temporary Protection of Header", Str. Sht. 77.

TABLE - C (SEE NOTE "A")

Bridge Number	Location	Skew \angle	Length Contributing to Expansion	Joint Length Gutter to Gutter	Refer to Structure Sheet No.
3303	Pier WE 18A	55°±	205'±	72.66'	74
3402 B	Pier EN 6	0°	122'±	22.0'	
3400 C	Pier 14A	0°	235'±	42.0'	

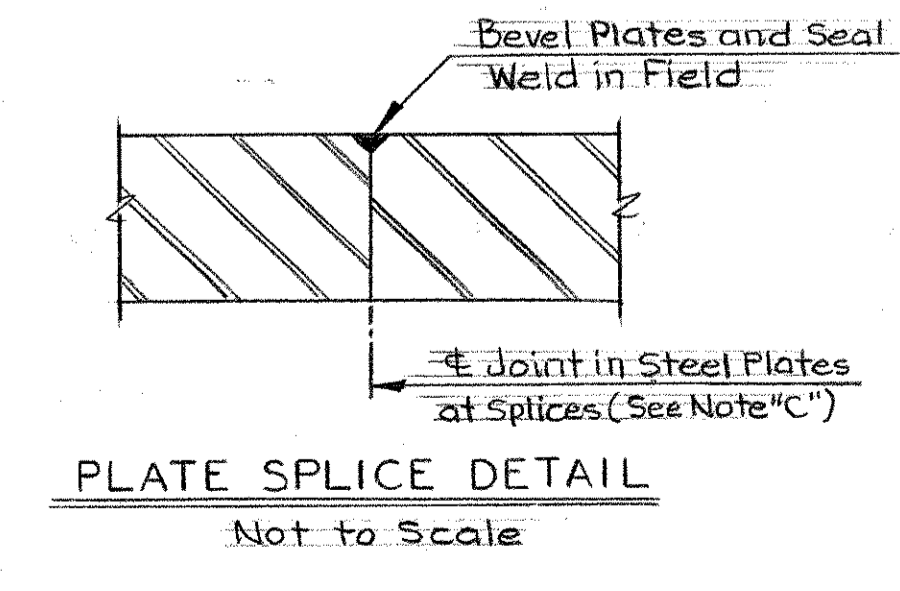

THE INFORMATION, INCLUDING ESTIMATED QUANTITIES OF WORK SHOWN ON THESE SHEETS IS BASED ON LIMITED INVESTIGATIONS BY THE STATE AND IS IN NO WAY WARRANTED TO INDICATE THE TRUE CONDITIONS OR ACTUAL QUANTITIES OR DISTRIBUTION OF QUANTITIES OF WORK WHICH WILL BE REQUIRED.

STATE OF CONNECTICUT
 DEPARTMENT OF TRANSPORTATION
 SOUTHINGTON - HARTFORD
 INTERSTATE ROUTE 84
 59 STRUCTURES
 DECK REPAIRS
 MODIFICATION TO FINGER JOINTS

ENGINEER: Bridge Design Unit
 DESIGNER: G.J.A. DRAFTER: F.T.R. CHECKER: G.D.B.
 APPROVED: [Signature] DATE: 3/17/82
 STRUCTURE NO. BRIDGE LOG NO. STRUCTURE SHEET NO. 79 of 87

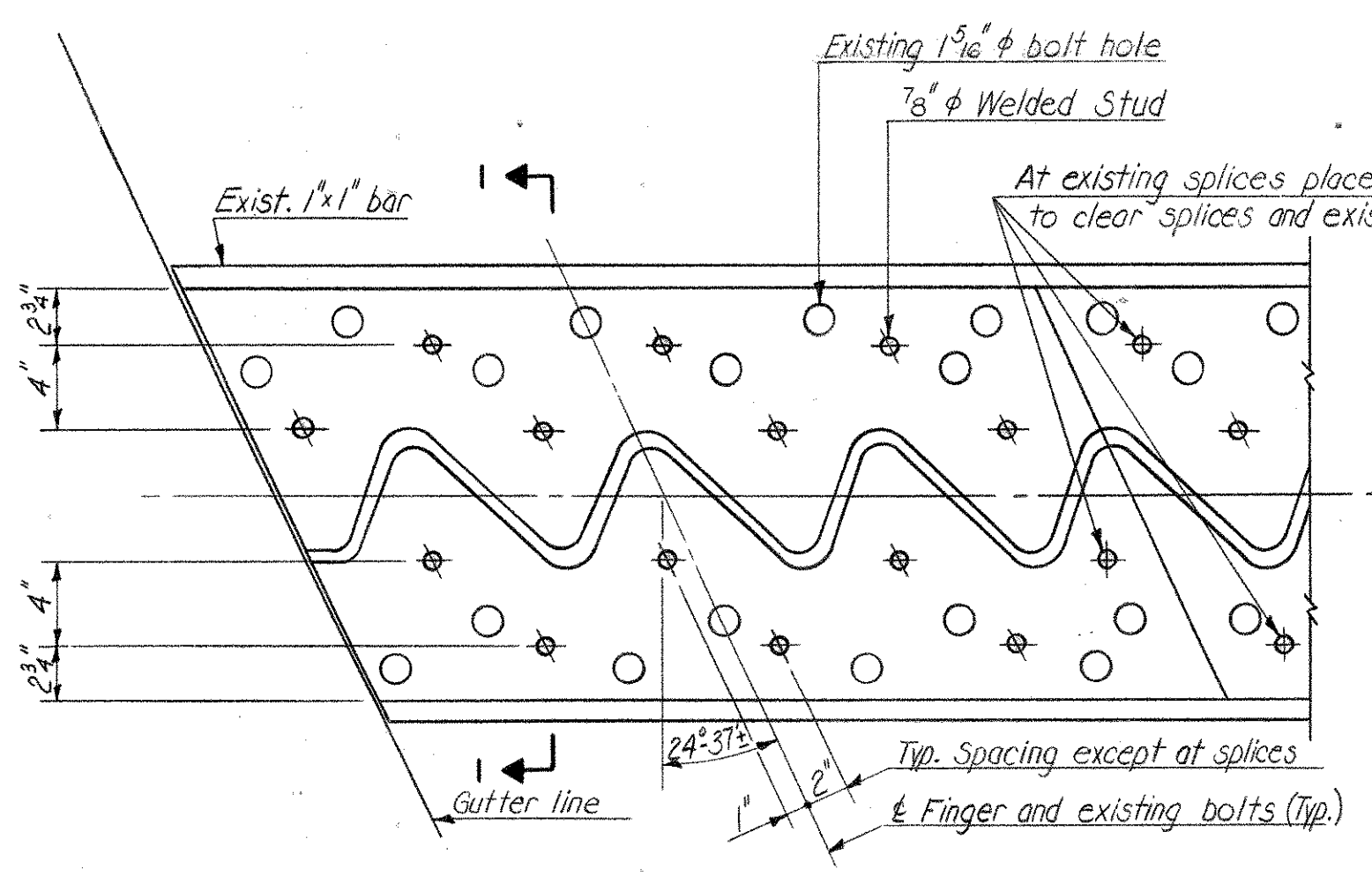

STUD LOCATION PLAN
 Bridge No. 3160A - Expansion Link
 Scale: 1 1/2" = 1'-0"

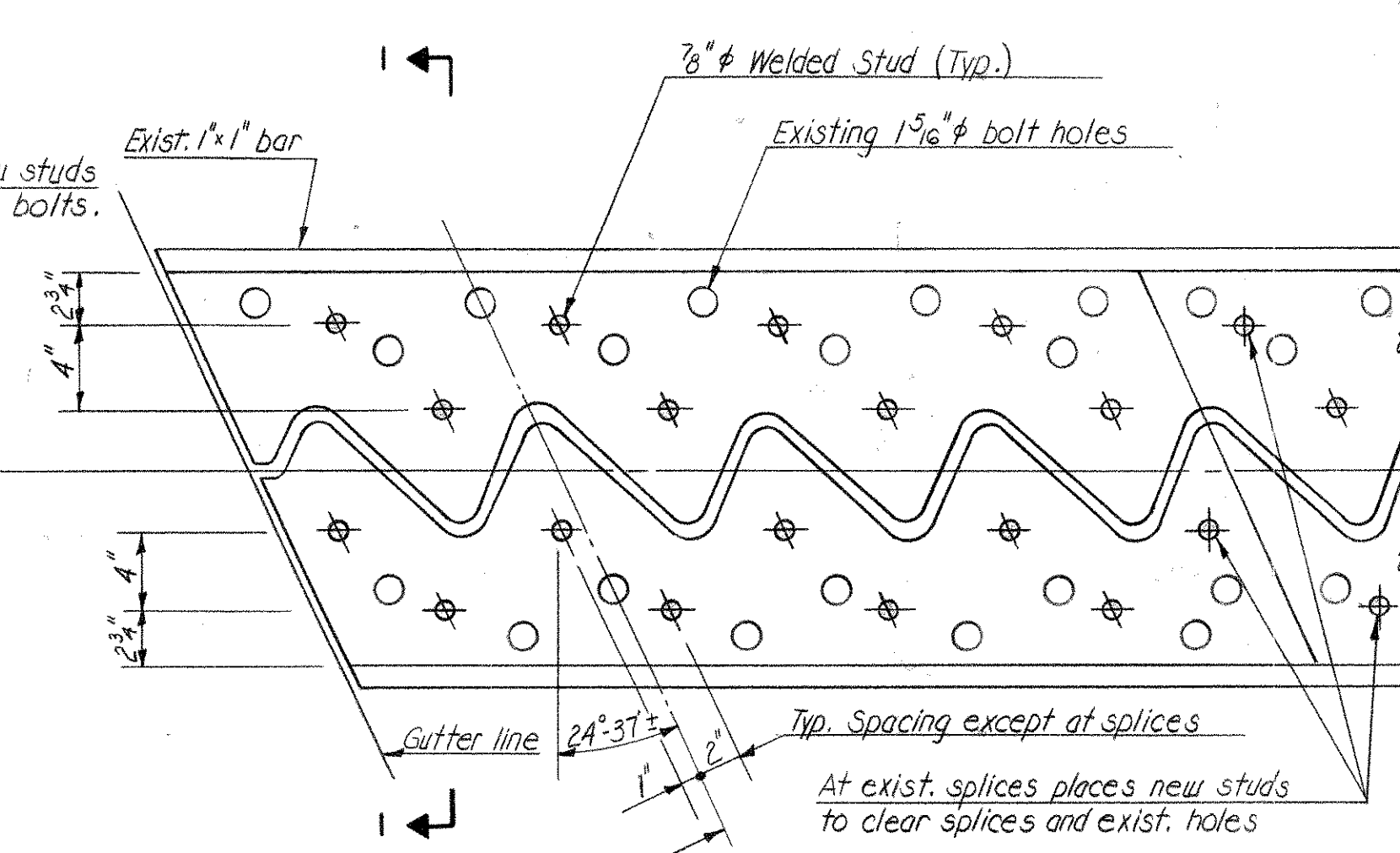

STUD LOCATION PLAN
 Bridge No. 3160B - Expansion Link
 Scale: 1 1/2" = 1'-0"

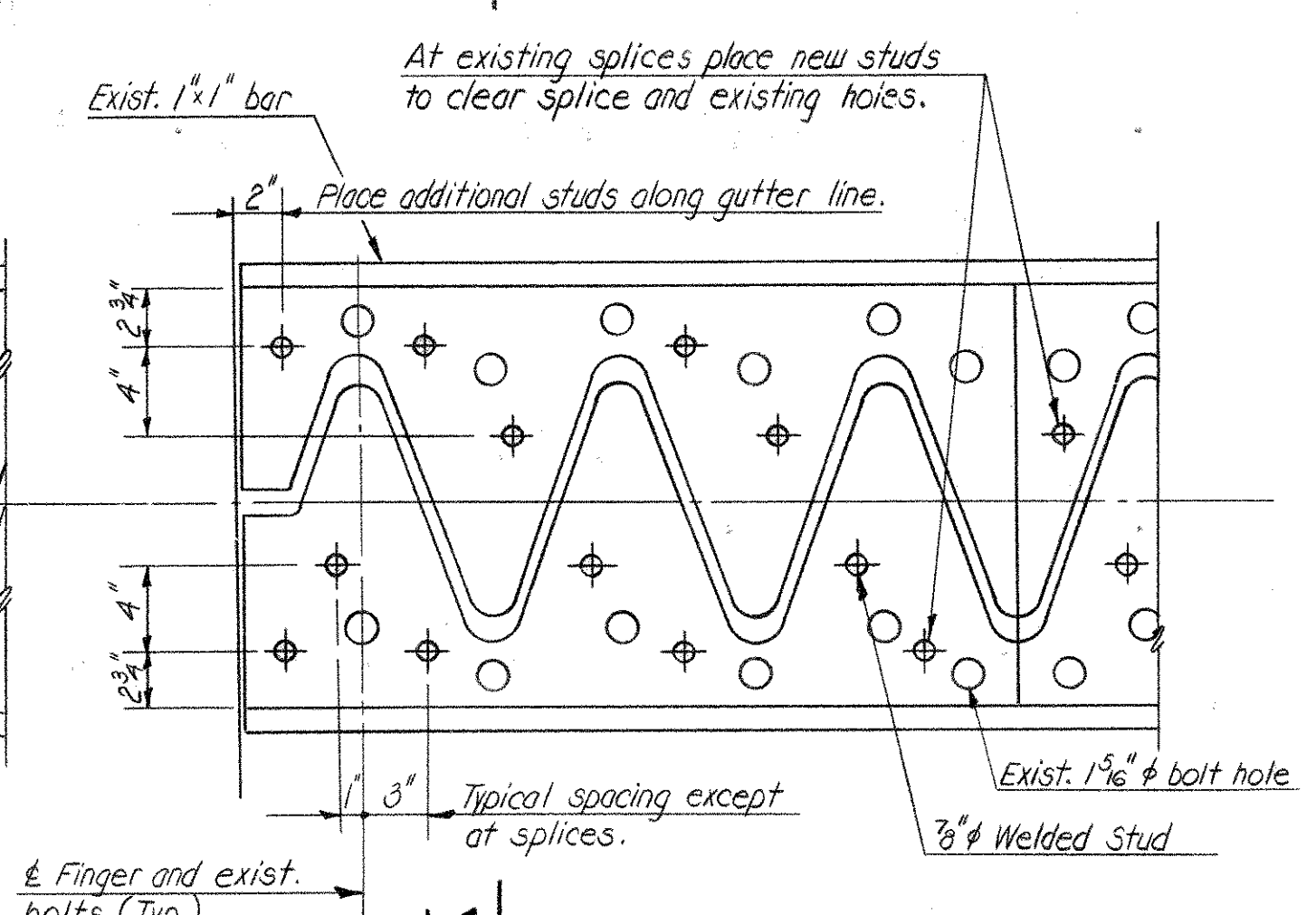

STUD LOCATION PLAN
 Bridges No. 3023, 3160C & 3160D
 Scale: 1 1/2" = 1'-0"

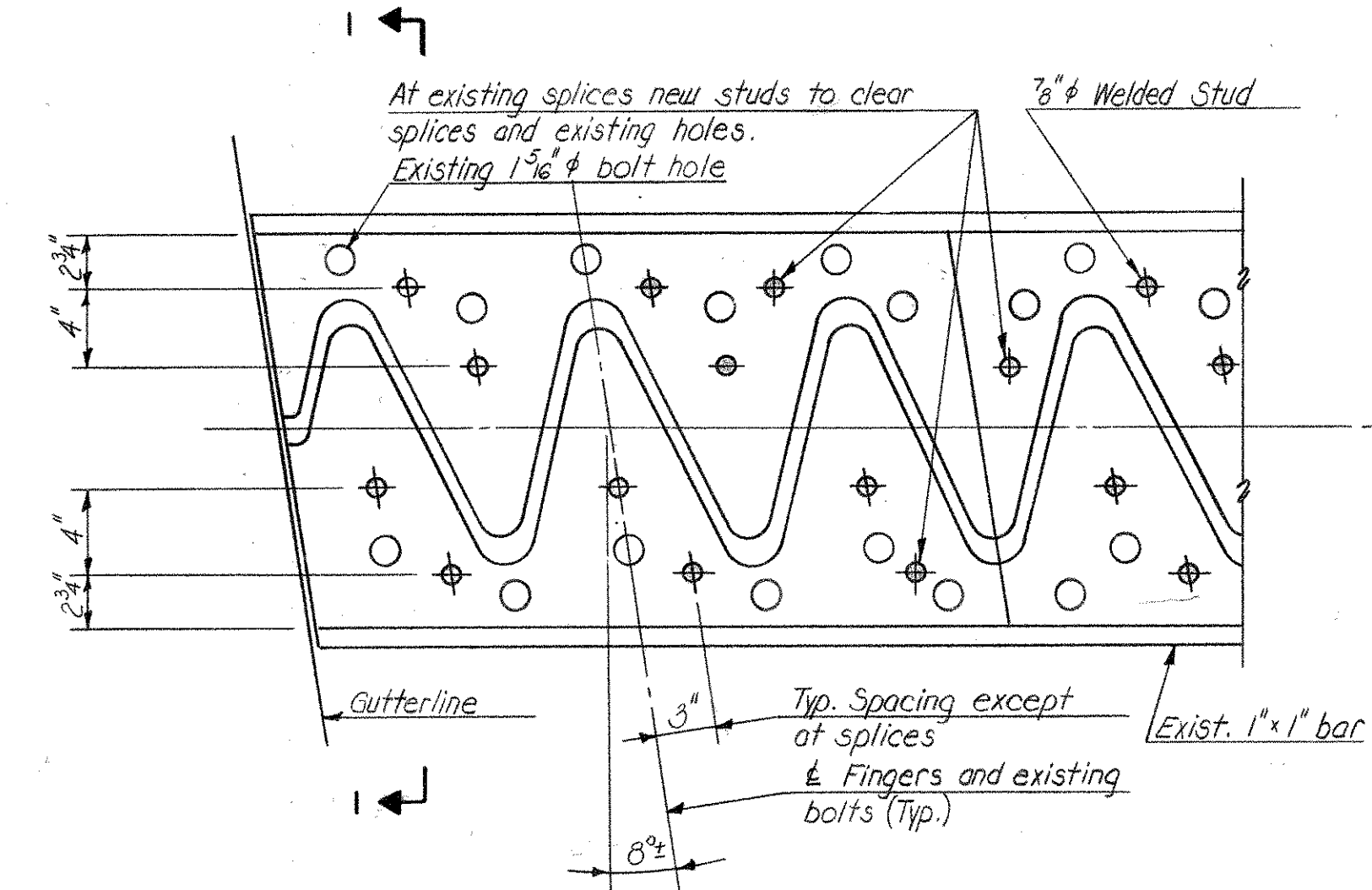

STUD LOCATION PLAN
 Bridge No. 3160A - PIER No. ML 14
 Scale: 1 1/2" = 1'-0"

TABLE - A (SEE NOTE "A")

Bridge Number	Location	Skew α	Length Contributing to Expansion	Joint Length Gutter to Gutter	Refer to Structure Sheet #
3023	Pier 5	0°	150'	2 @ 38'	76
3160A	Pier ML 11	11° 46' ±	160'	55.145'	67
3160B	Pier ML 11	11° 46' ±	190'	55.125'	67
3160A	Exp. Link	24° 37' ±	142'	59.51'	67
3160B	Exp. Link	24° 37' ±	142'	59.38'	67
3160A	Pier ML 14	8°	194'	54.557'	68
3160C	Pier EBR 2	0°	140'	31.74'	68
3160D	Pier WBR 2	0°	135'	30.0'	68

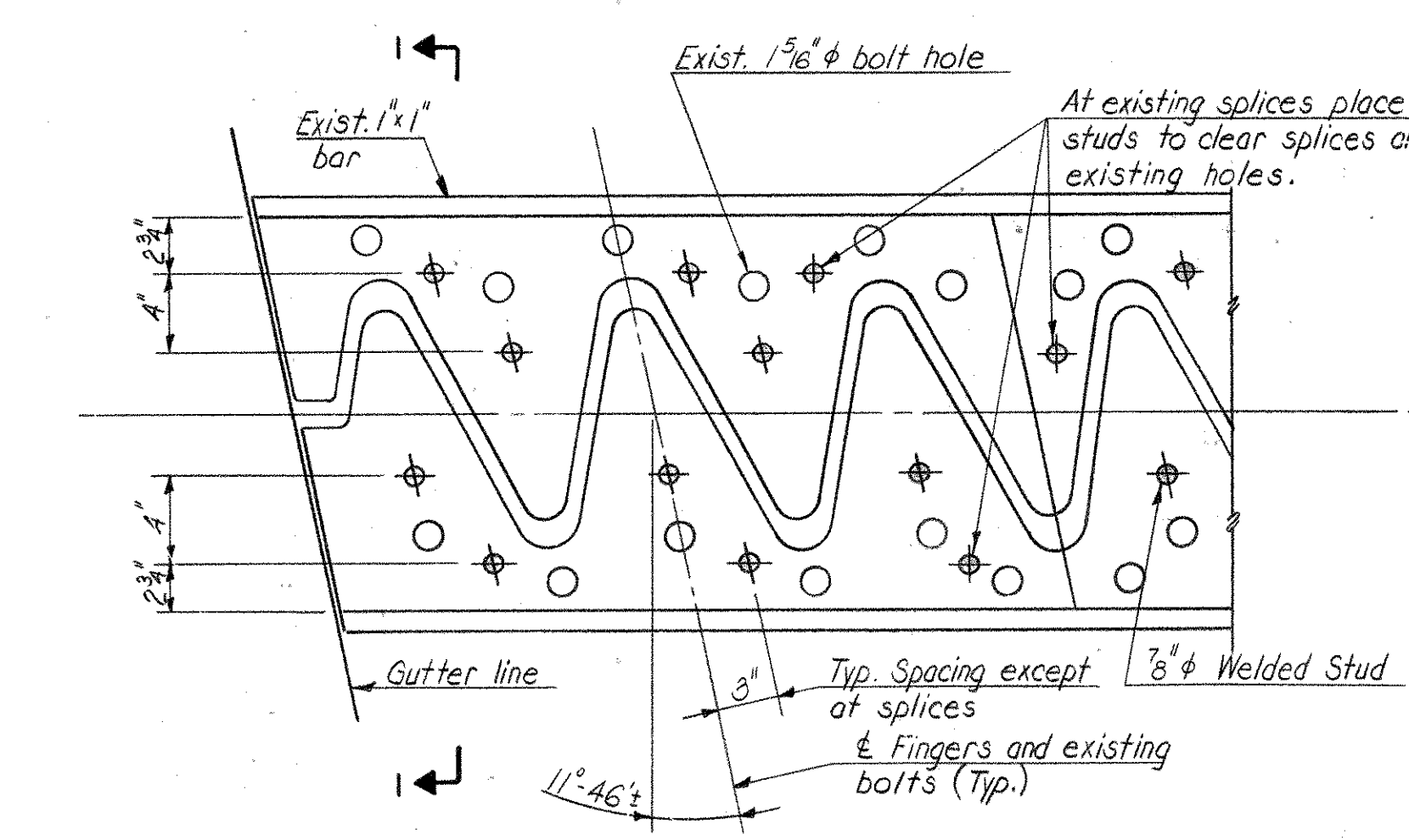

STUD LOCATION PLAN
 Bridge No. 3160A - PIER No. ML 11
 Scale: 1 1/2" = 1'-0"

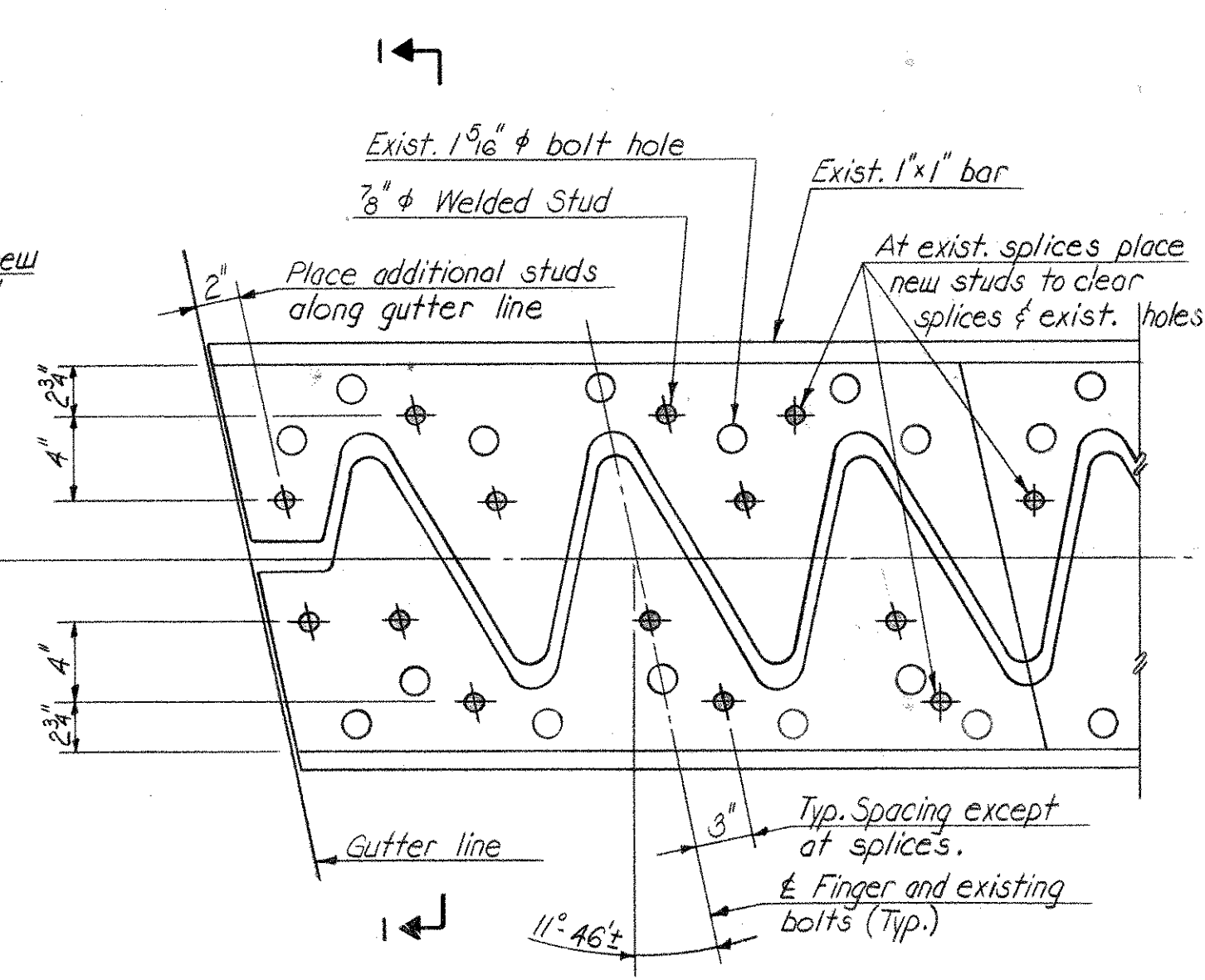

STUD LOCATION PLAN
 Bridge No. 3160B - PIER No. ML 11
 Scale: 1 1/2" = 1'-0"

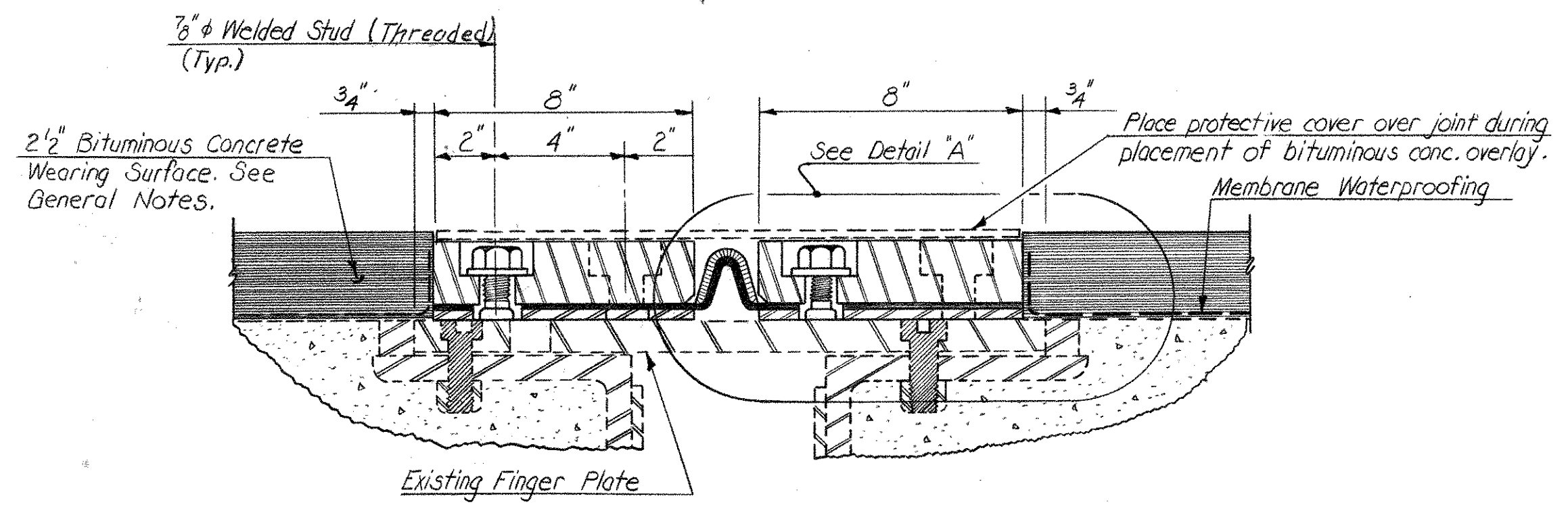

SECTION 1-1
 Scale: 3" = 1'-0"

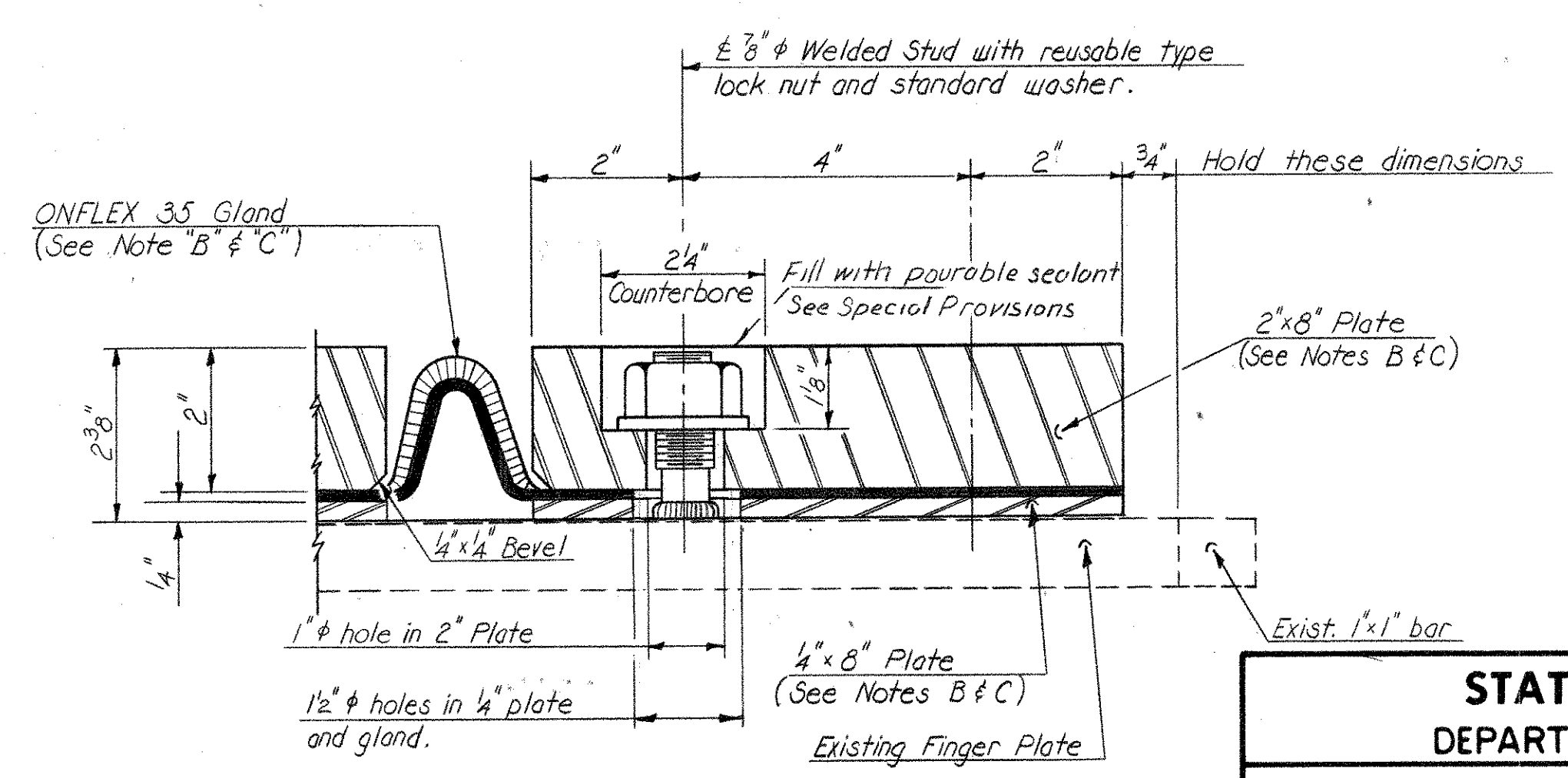

DETAIL - A
 Scale: Half Size

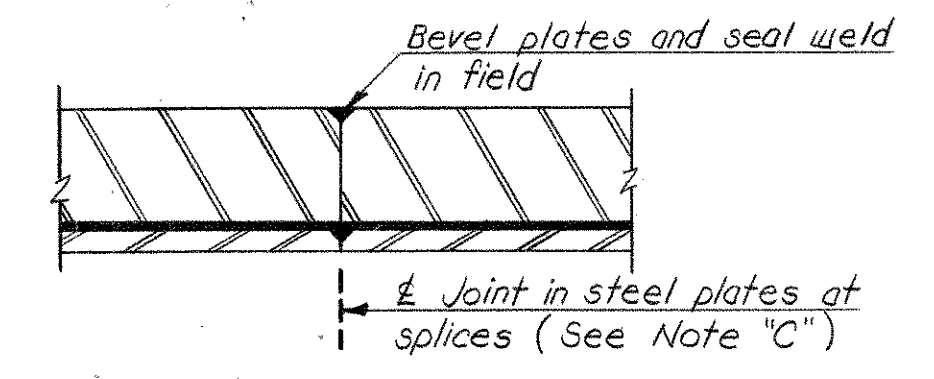

PLATE SPLICE DETAIL

- NOTES:**
- A: All data shown in "TABLE A" and information showing existing conditions was taken from the original contract plans and shop plans. These plans are available to the Contractor by request of the Engineer. The Contractor shall verify all data before fabrication of the new joint components.
 - B: The cost of furnishing and installing plates, glands and 7/8" studs shall be included in the contract unit price for "Prefabricated Expansion Joint Device (Movement Capacity 3")".
 - C: Plates shall be installed in continuous lengths wherever possible, joints shall be held to a minimum, consistent with the requirements for "Maintenance and Protection of Traffic," shop fabrication and actual field conditions. ONFLEX 35 Gland shall be installed in lengths consistent with the special provisions.
 - D: Temporary protection of joints shall be provided as shown on "Temporary Protection of Header", Str. Sht. 77

STATE OF CONNECTICUT
 DEPARTMENT OF TRANSPORTATION
 SOUTHINGTON - HARTFORD
 INTERSTATE ROUTE 84
 59 STRUCTURES
 DECK REPAIRS
 PREFABRICATED EXPANSION JOINT DEVICE
 (3" MOVEMENT CAPACITY) (JOINT DEVICE "A")

ENGINEER BRIDGE DESIGN UNIT	
DESIGNER G. J. A.	CHECKER G. D. B.
APPROVED <i>[Signature]</i>	DATE 3/17/82
NO. DATE	DESCRIPTION
REVISIONS	
STRUCTURE NO.	BRIDGE LOG NO. 80 OF 87

THE INFORMATION, INCLUDING ESTIMATED QUANTITIES OF WORK SHOWN ON THESE SHEETS IS BASED ON LIMITED INVESTIGATIONS BY THE STATE AND IS IN NO WAY WARRANTED TO INDICATE THE TRUE CONDITIONS OR ACTUAL QUANTITIES OR DISTRIBUTION OF QUANTITIES OF WORK WHICH WILL BE REQUIRED.

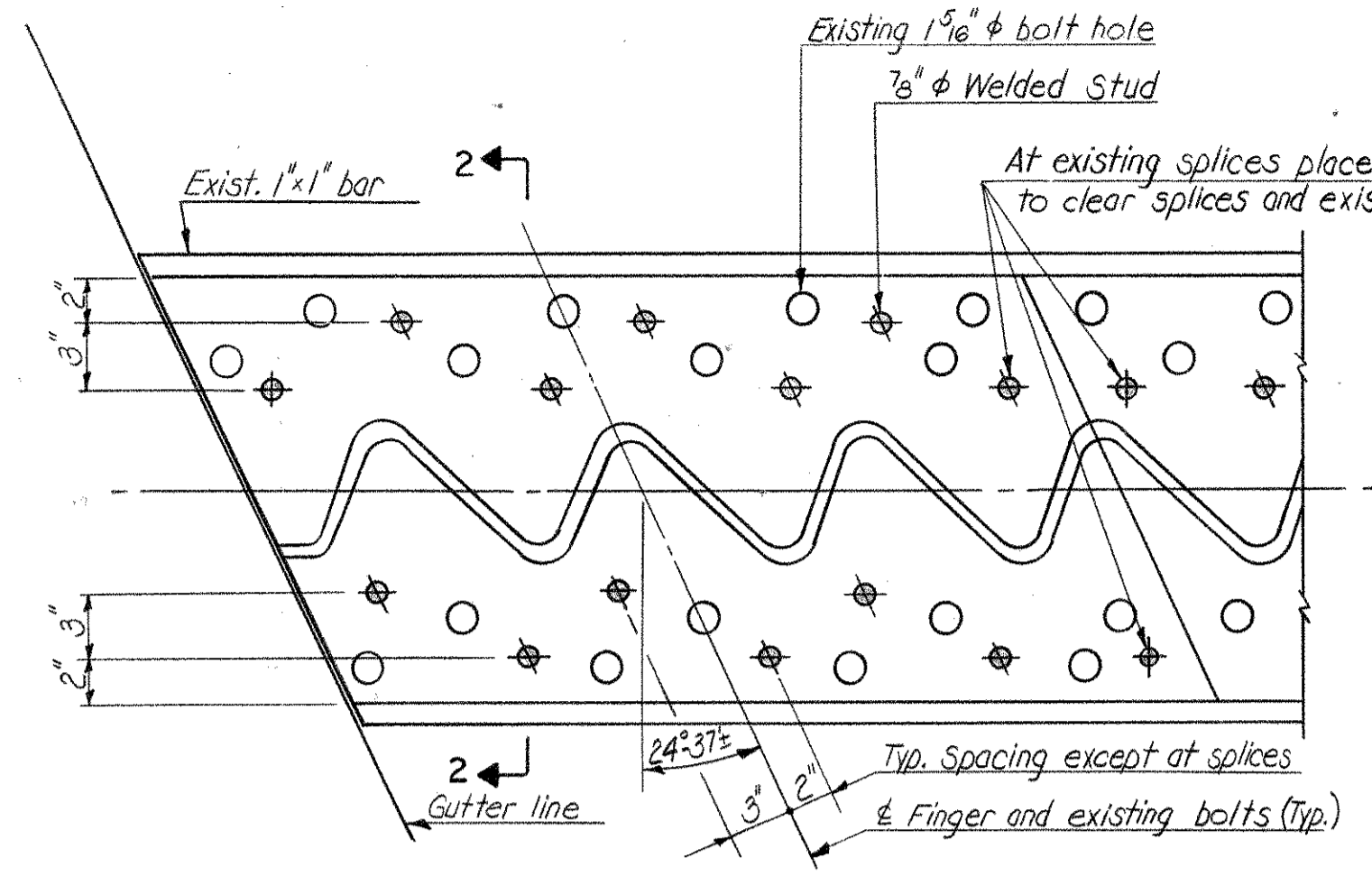

STUD LOCATION PLAN
 Bridge No. 3160A - Expansion Link
 Scale: 1/2" = 1'-0"

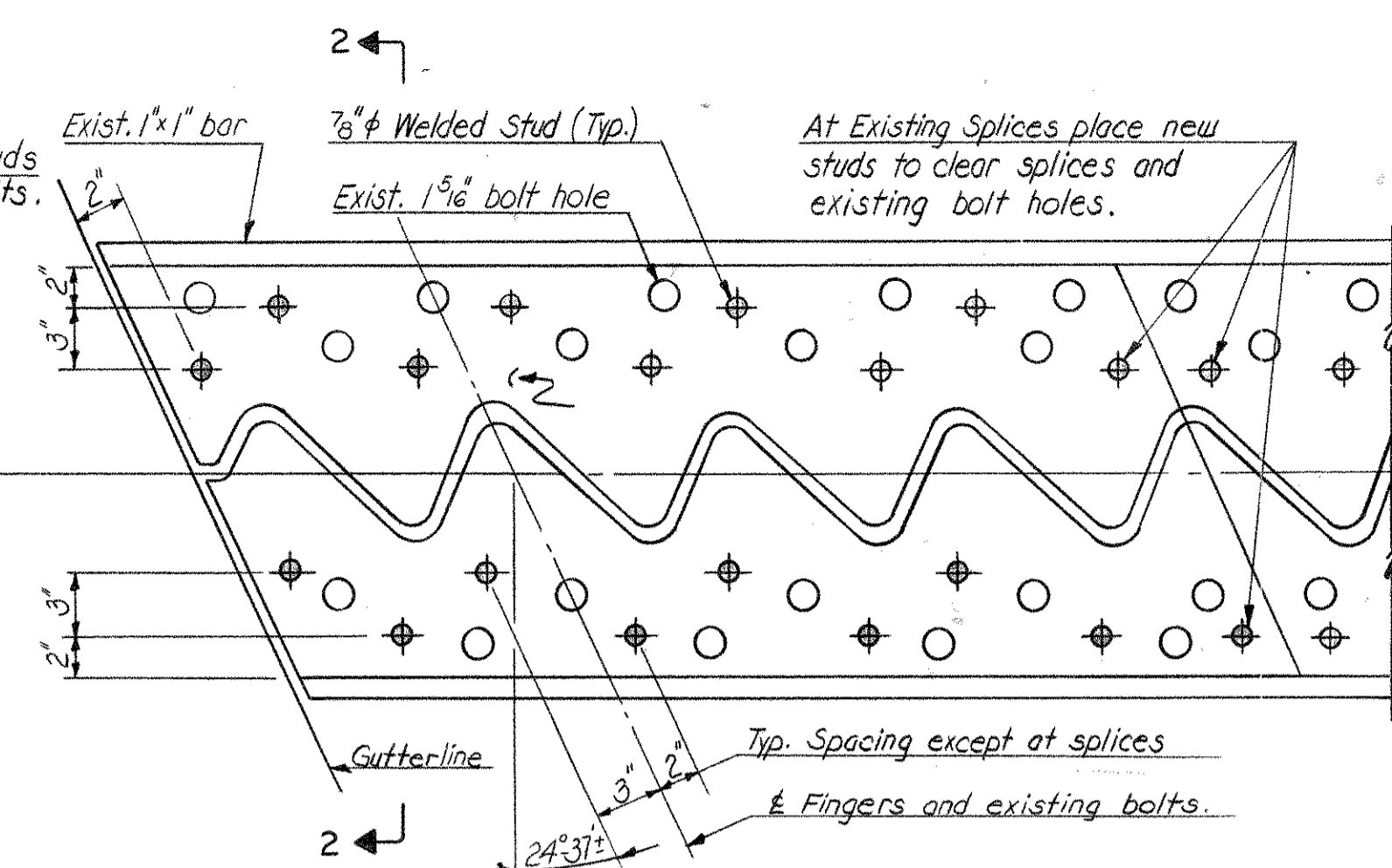

STUD LOCATION PLAN
 Bridge No. 3160B - Expansion Link
 Scale: 1/2" = 1'-0"

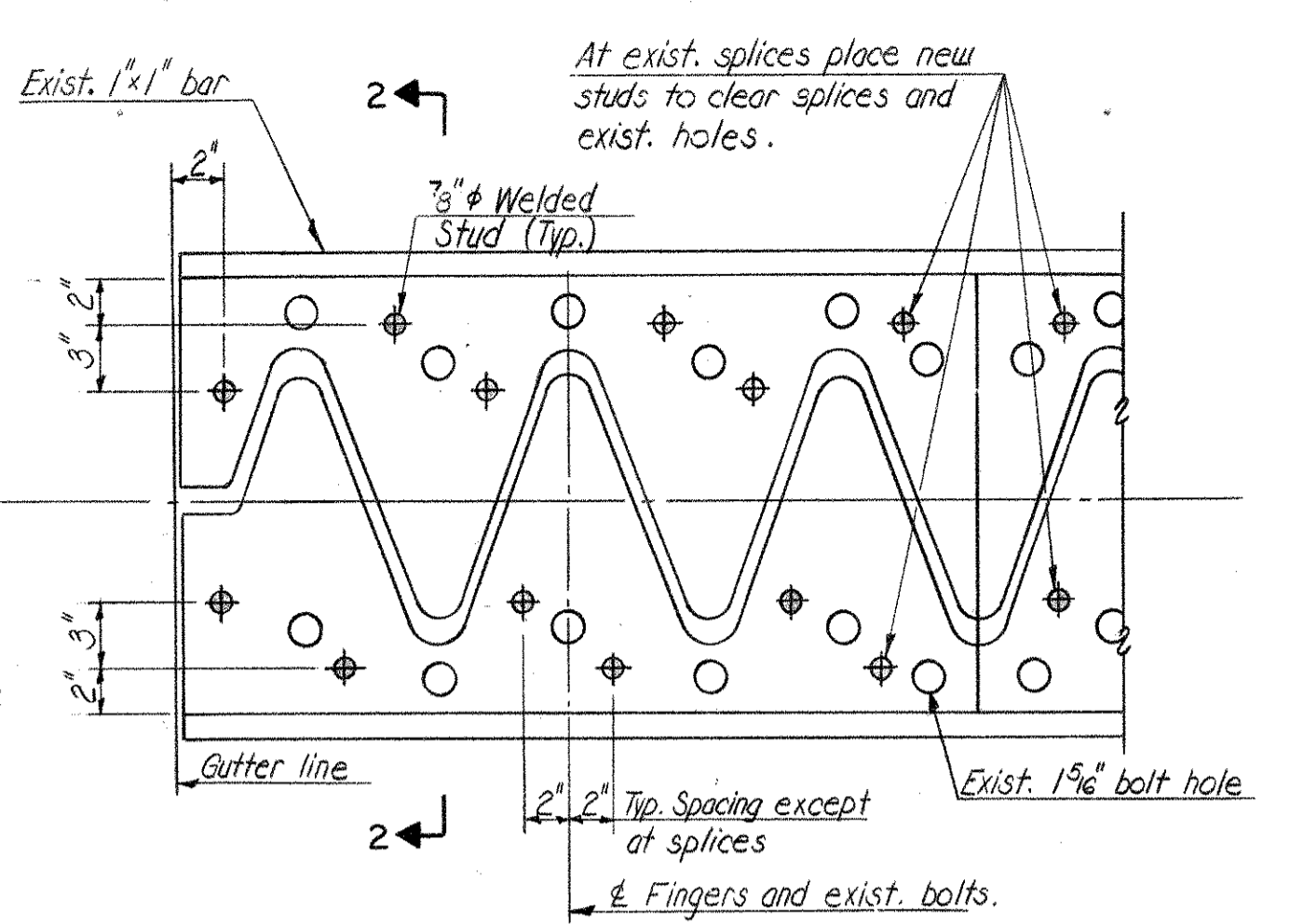

STUD LOCATION PLAN
 Bridges No. 3023, 3160C & 3160D
 Scale: 1/2" = 1'-0"

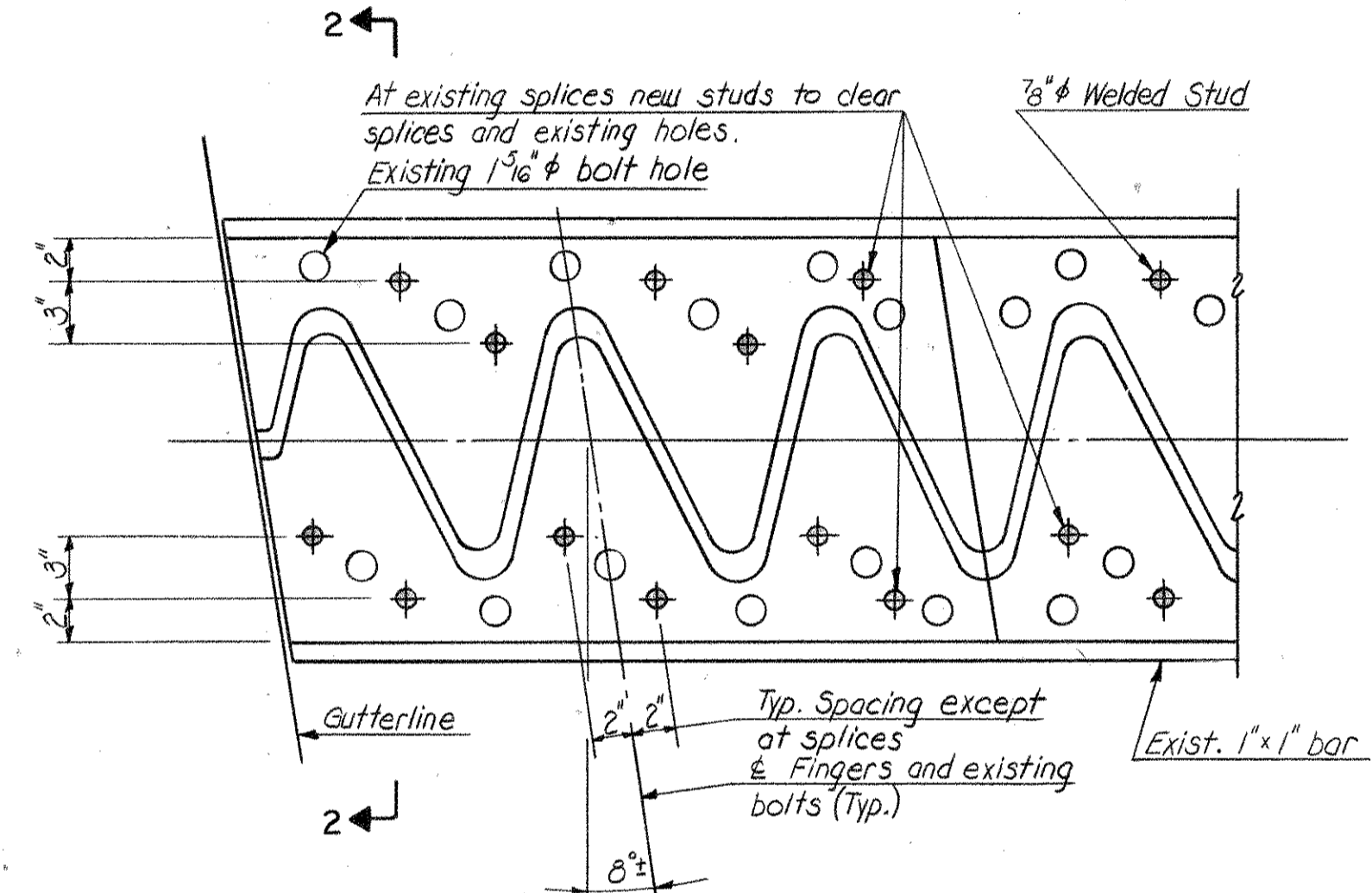

STUD LOCATION PLAN
 Bridge No. 3160A - PIER No. ML 14
 Scale: 1/2" = 1'-0"

TABLE - B (SEE NOTE "A")

Bridge Number	Location	Skew Δ	Length Contributing to Expansion	Joint Length Gutter to Gutter	Refer to Structure Sheet #
3023	Pier 5	0°	150'	2 @ 38'	76
3160A	Pier ML 12	11°-46 1/2'	160'	55.145'	67
3160B	Pier ML 12	11°-46 1/2'	190'	55.125'	67
3160A	Exp. Link	24°-37 1/2'	142'	59.51'	67
3160B	Exp. Link	24°-37 1/2'	142'	59.38'	67
3160A	Pier ML 14	8°	194'	54.557'	68
3160C	Pier EBR 2	0°	140'	31.74'	68
3160D	Pier WBR 2	0°	155'	30.0'	68

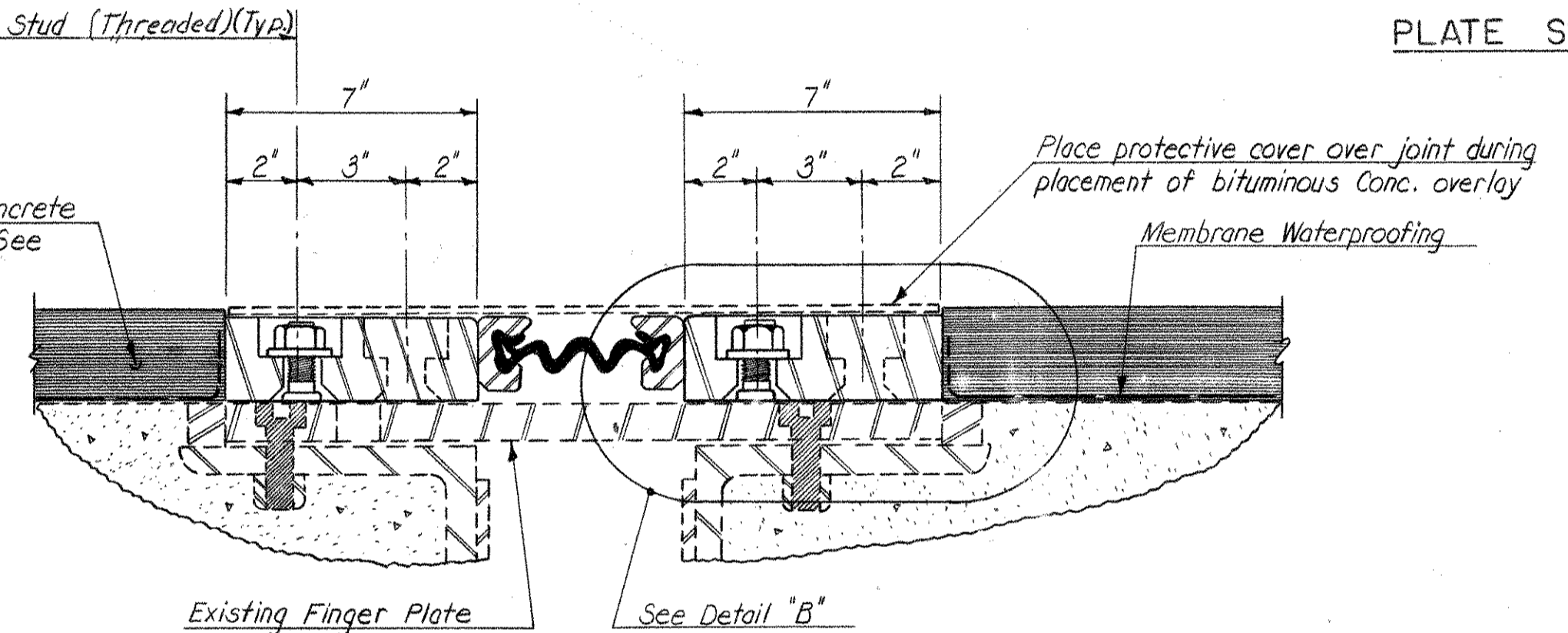

SECTION 2-2
 Scale: 3" = 1'-0"

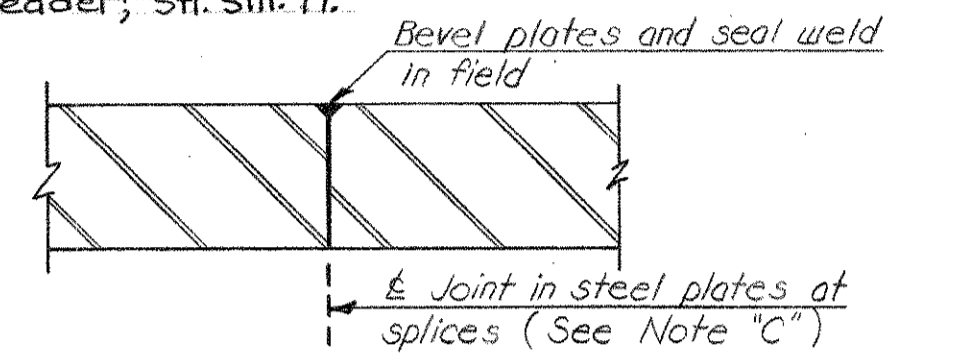
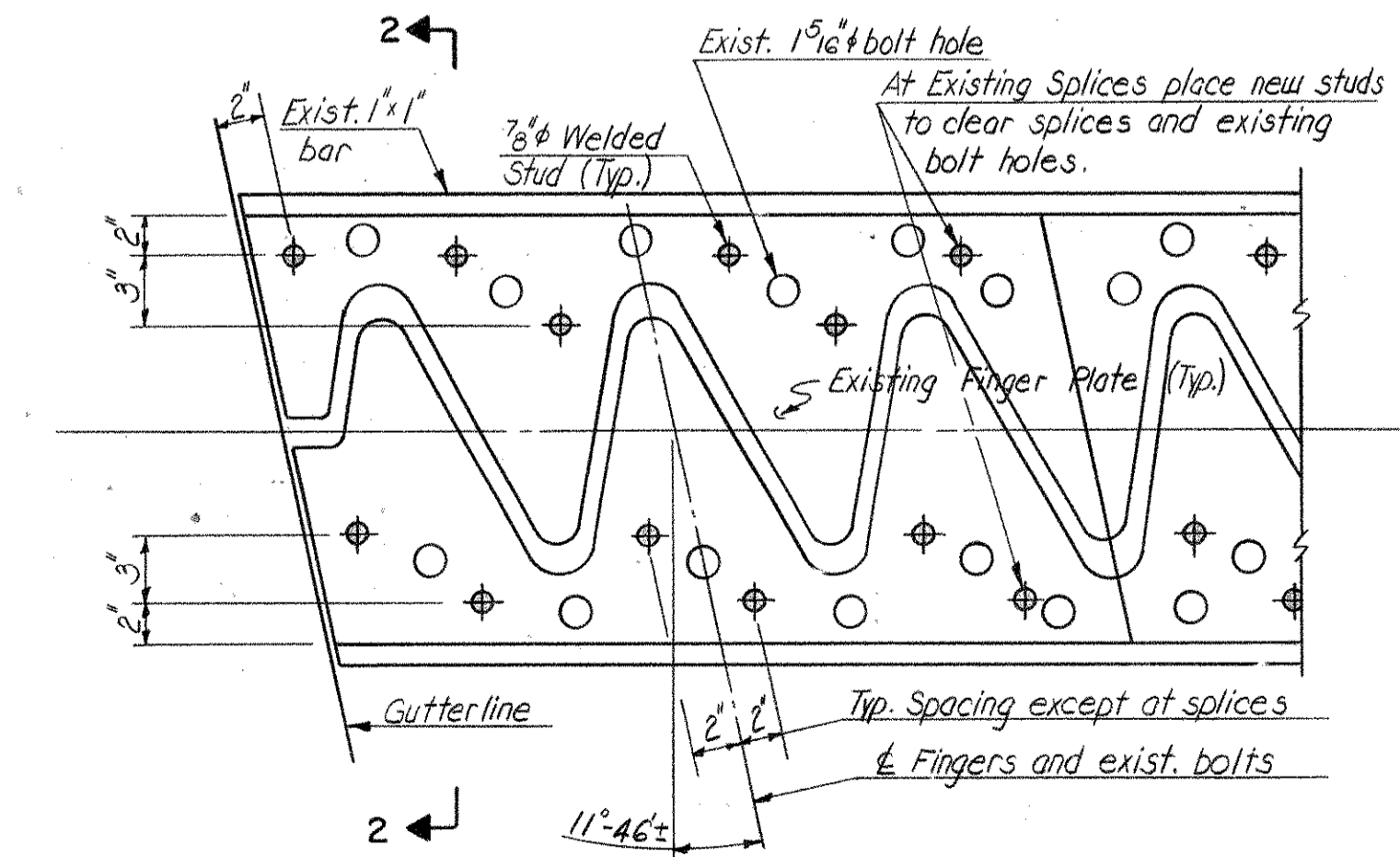
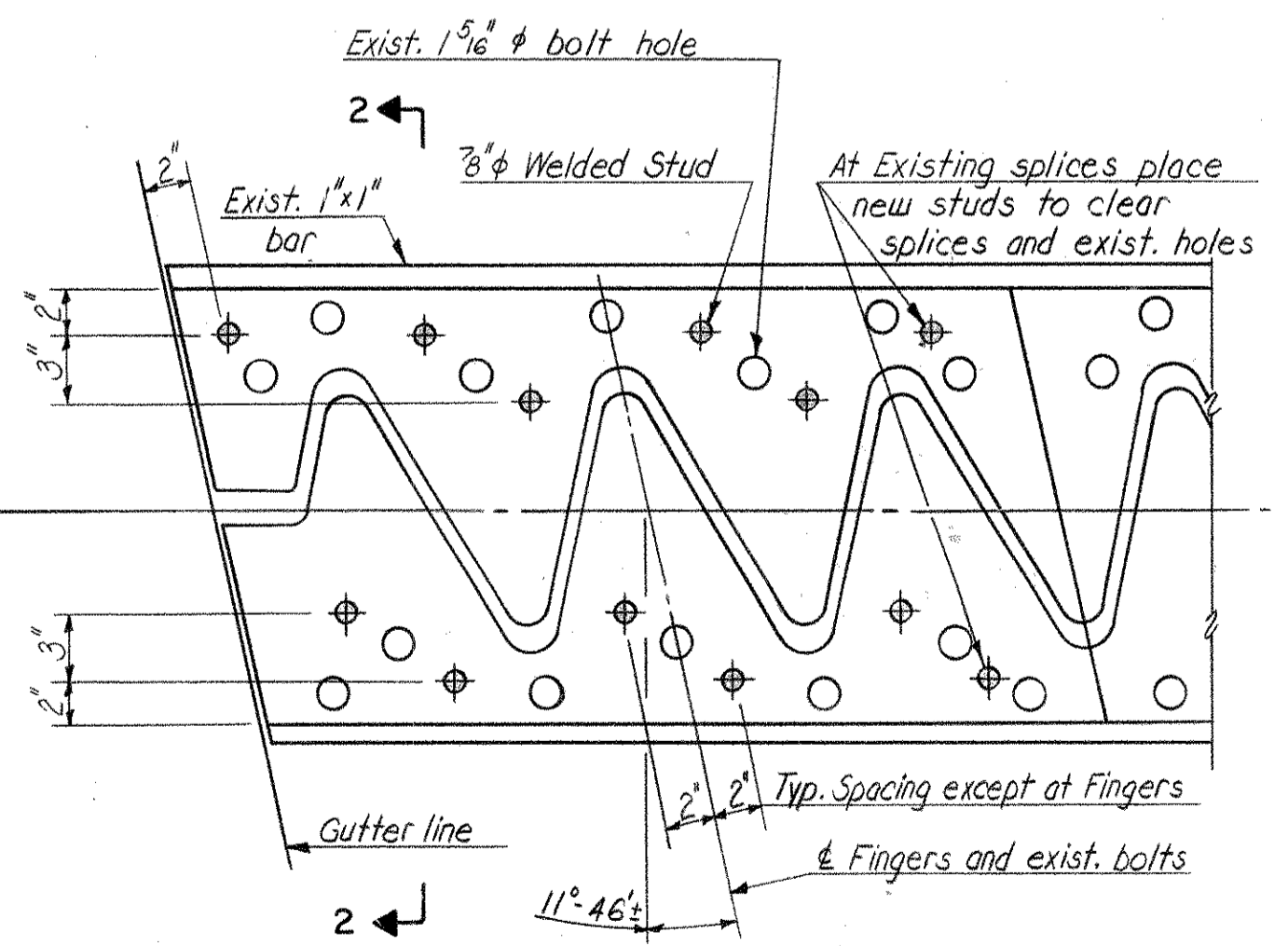

PLATE SPLICE DETAIL



STUD LOCATION PLAN
 Bridge No. 3160A - PIER No. ML 12
 Scale: 1/2" = 1'-0"



STUD LOCATION PLAN
 Bridge No. 3160B - PIER No. ML 12
 Scale: 1/2" = 1'-0"

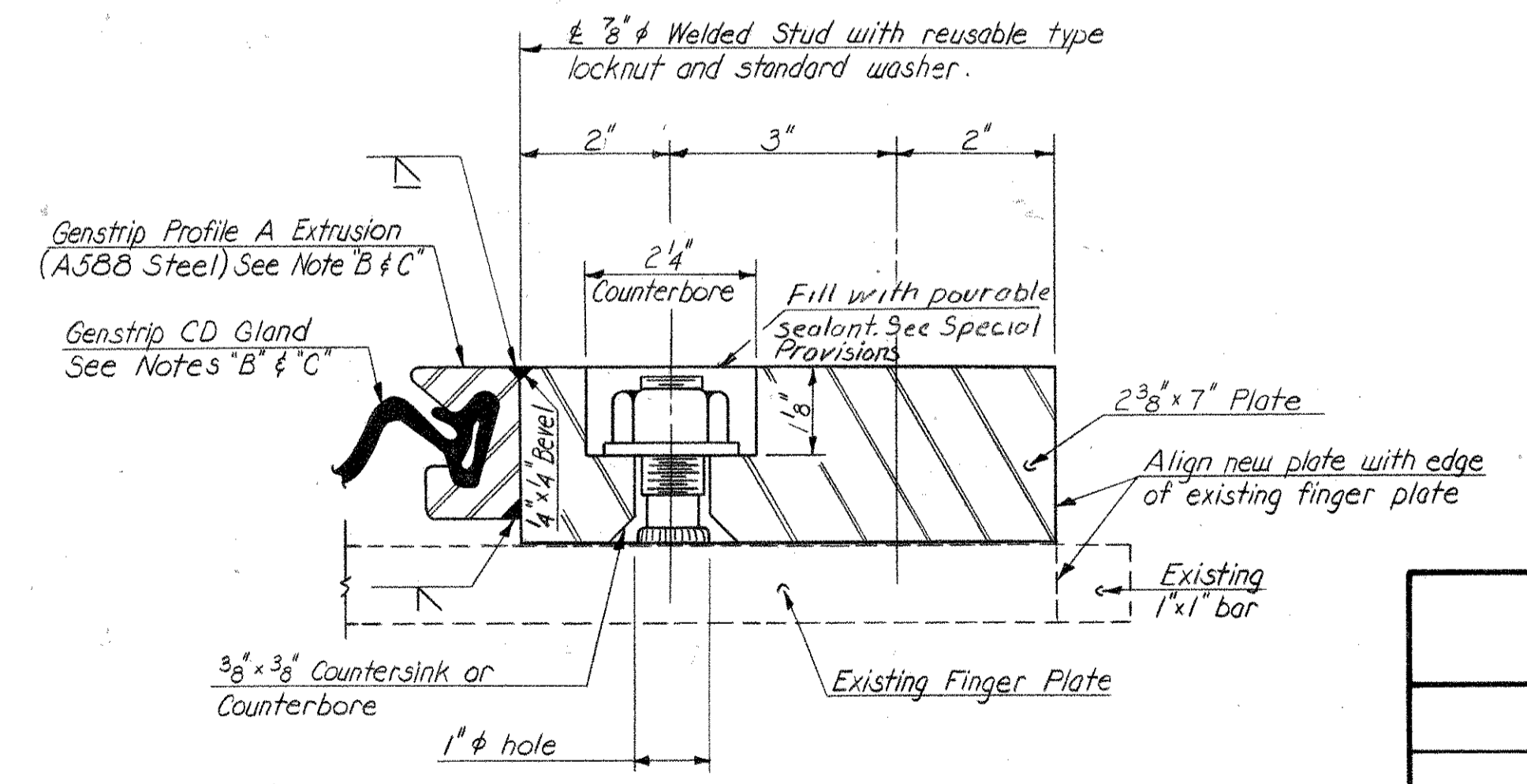

DETAIL - B
 Scale: Half Size

STATE OF CONNECTICUT
 DEPARTMENT OF TRANSPORTATION
 SOUTHINGTON - HARTFORD

INTERSTATE ROUTE 84

59 STRUCTURES

DECK REPAIRS

PREFABRICATED EXPANSION JOINT DEVICE (3' MOVEMENT CAPACITY) (JOINT DEVICE "B")

ENGINEER BRIDGE DESIGN UNIT

DESIGNER G.J.A. DRAFTER J.J.C. CHECKER G.D.B.

APPROVED [Signature] DATE 3/17/82

NO. DATE DESCRIPTION

REVISIONS

STRUCTURE NO. BRIDGE LOG NO. STRUCTURE SHEET NO. 81 of 87

THE INFORMATION, INCLUDING ESTIMATED QUANTITIES OF WORK SHOWN ON THESE SHEETS IS BASED ON LIMITED INVESTIGATIONS BY THE STATE AND IS IN NO WAY WARRANTED TO INDICATE THE TRUE CONDITIONS OR ACTUAL QUANTITIES OR DISTRIBUTION OF QUANTITIES OF WORK WHICH WILL BE REQUIRED.

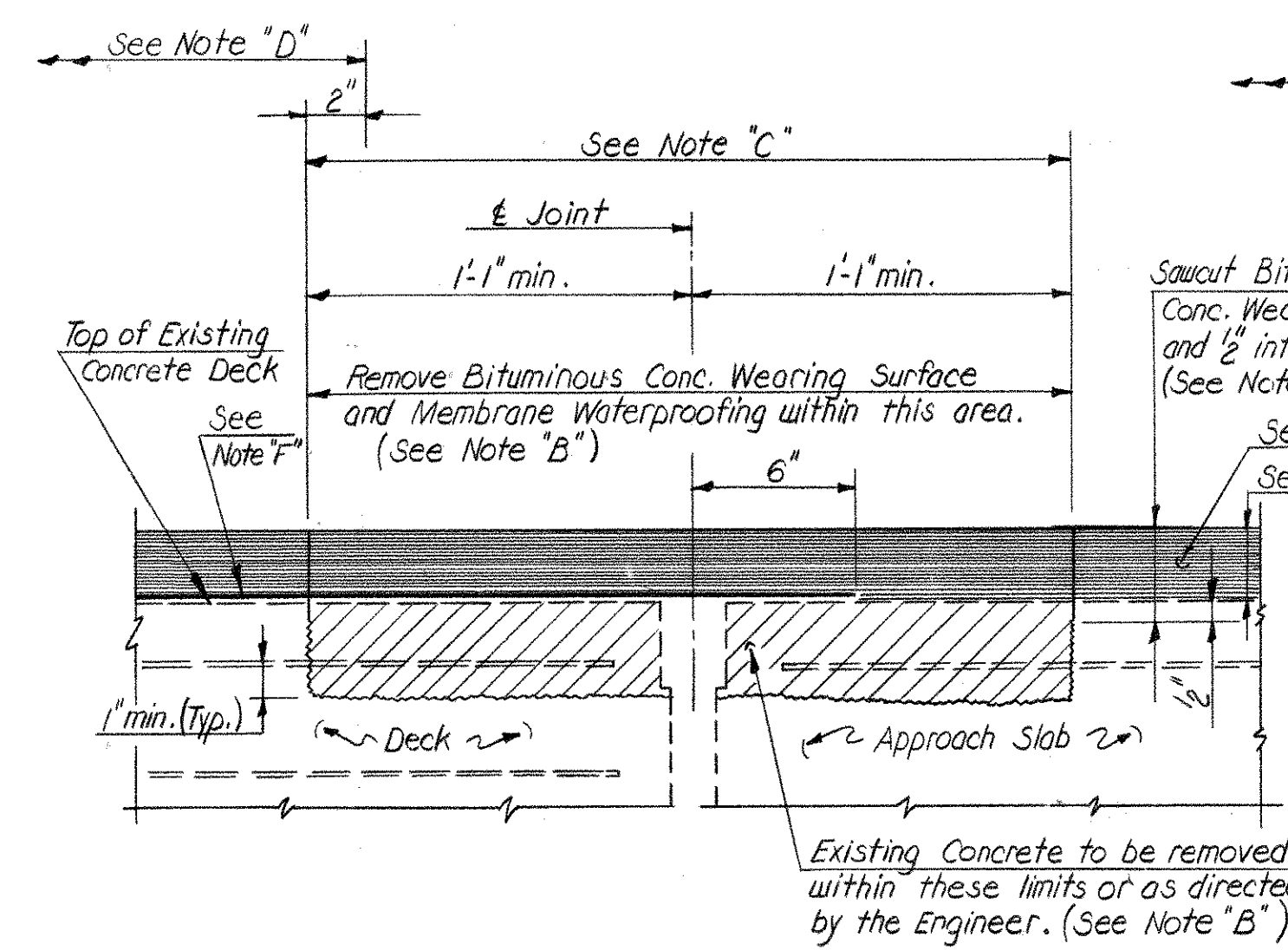

EXISTING CONDITION
Shown after placing wearing surface.

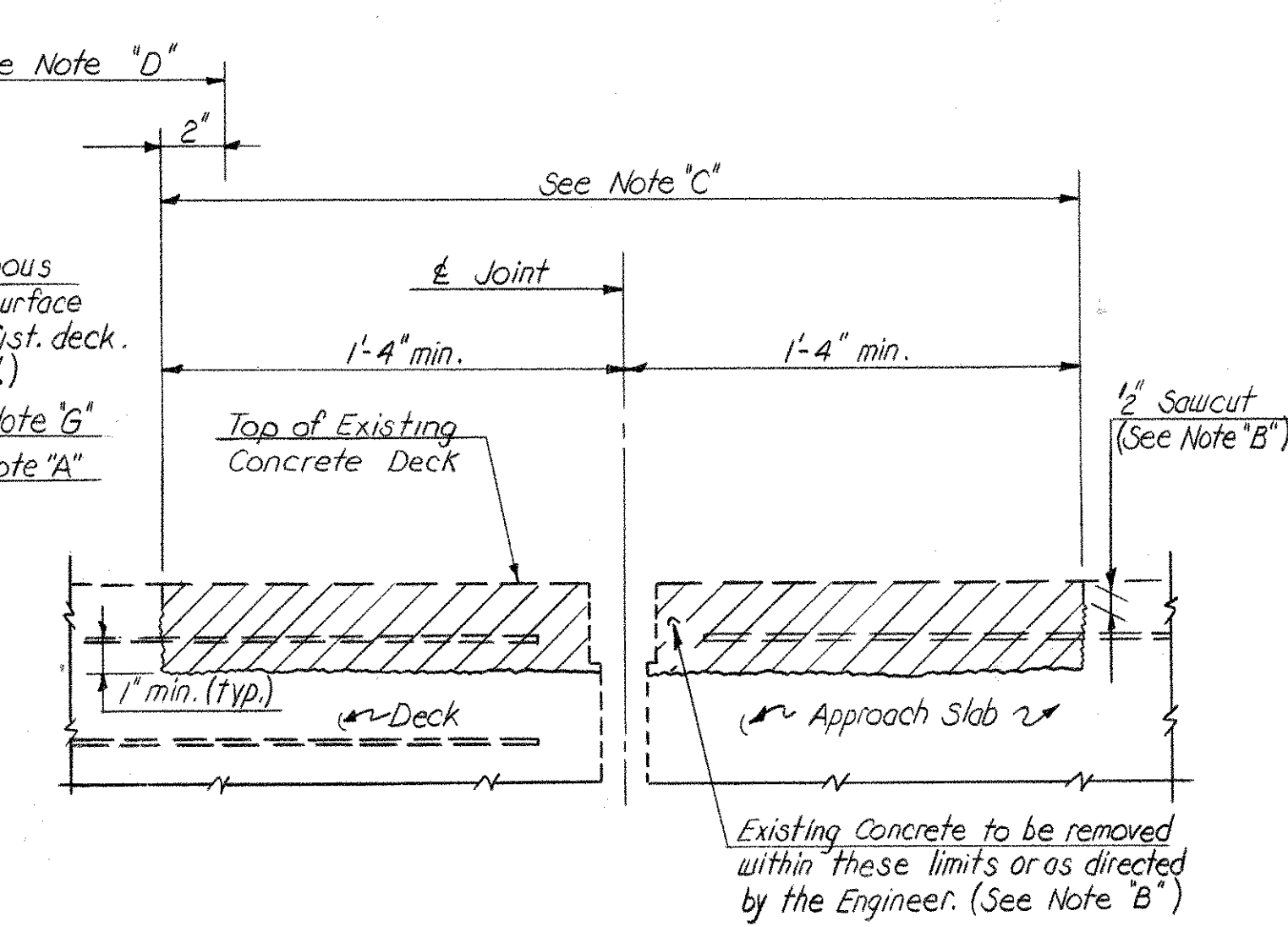

EXISTING CONDITION

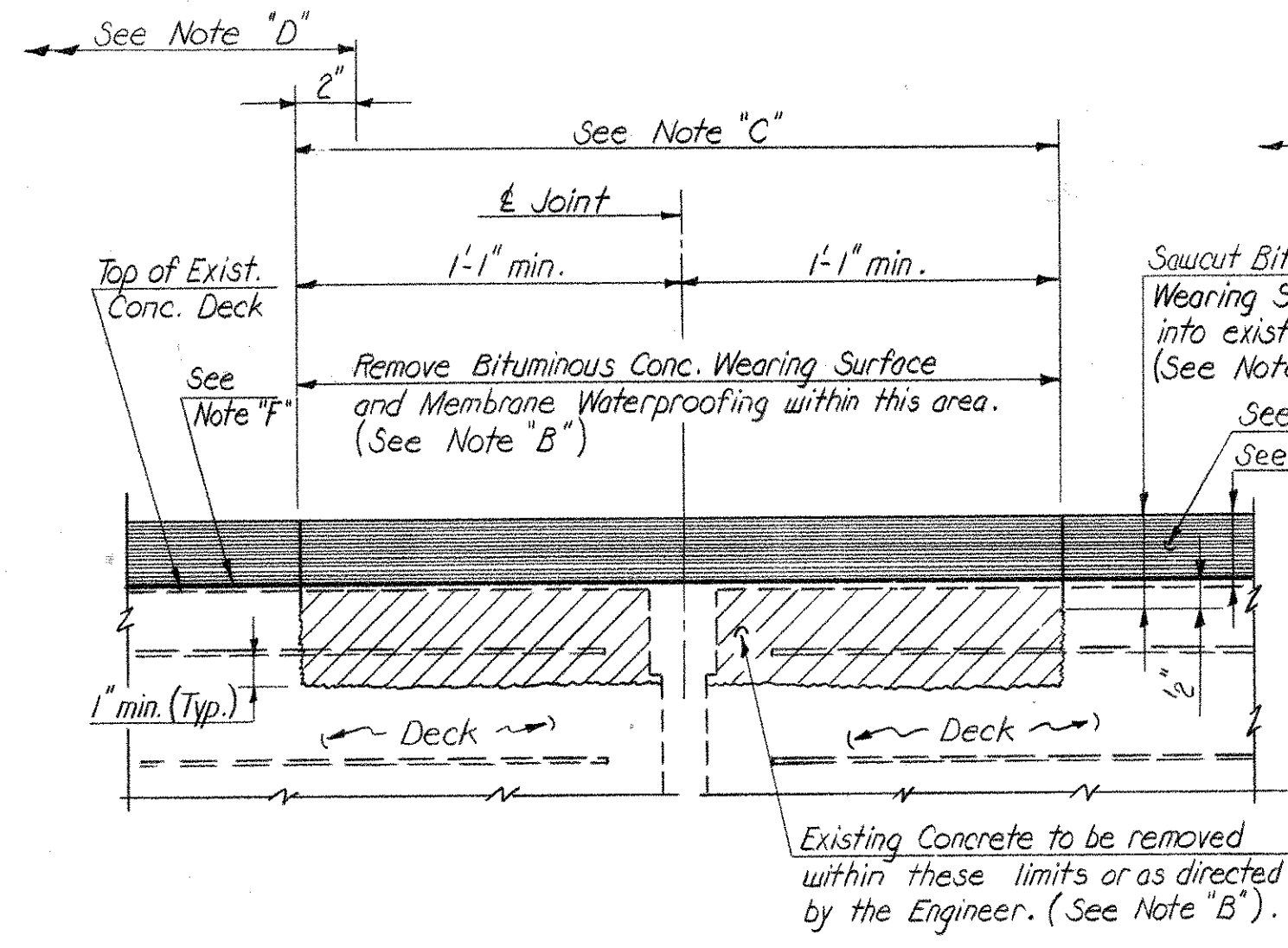

EXISTING CONDITION
Shown after placing wearing surface.

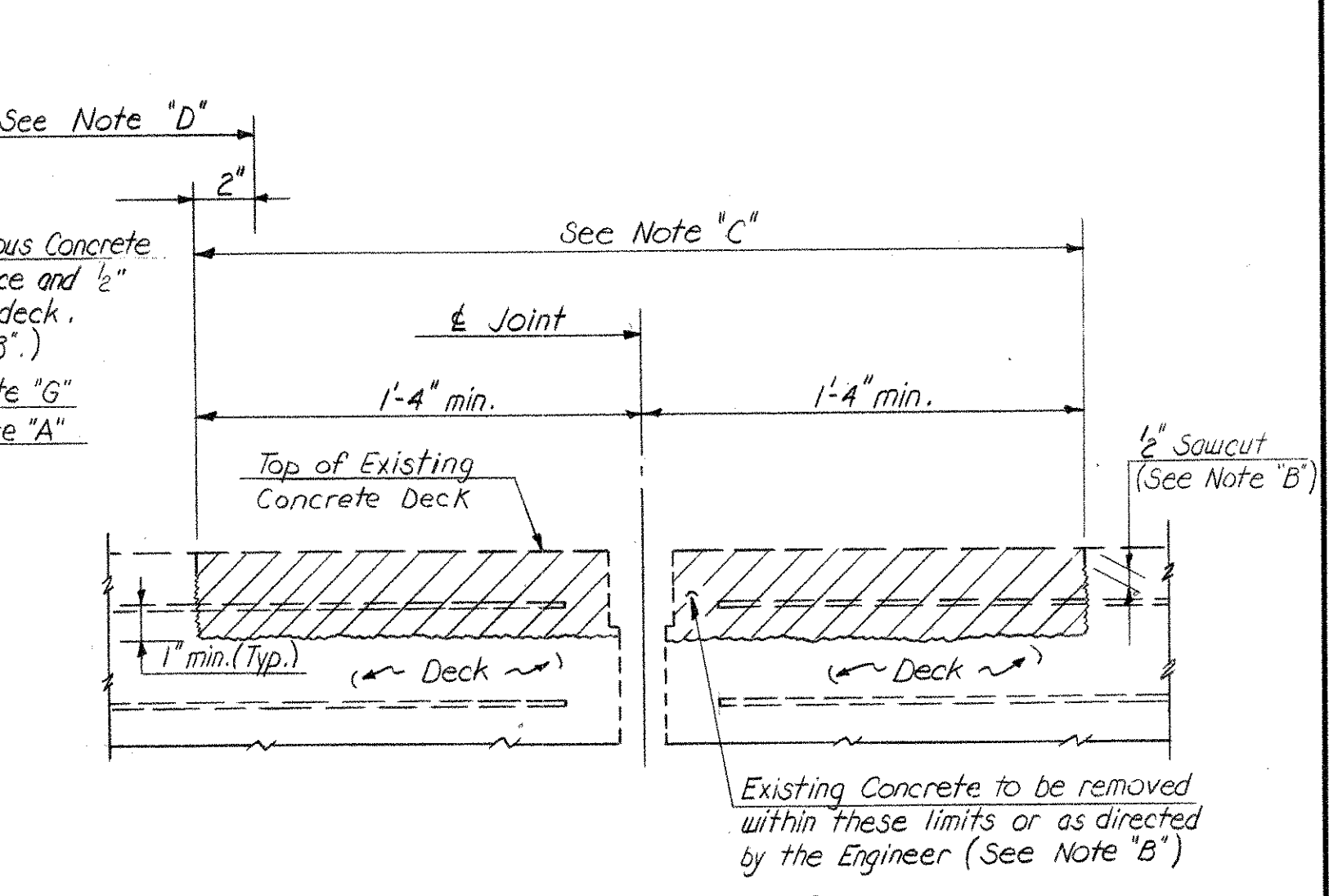

EXISTING CONDITION

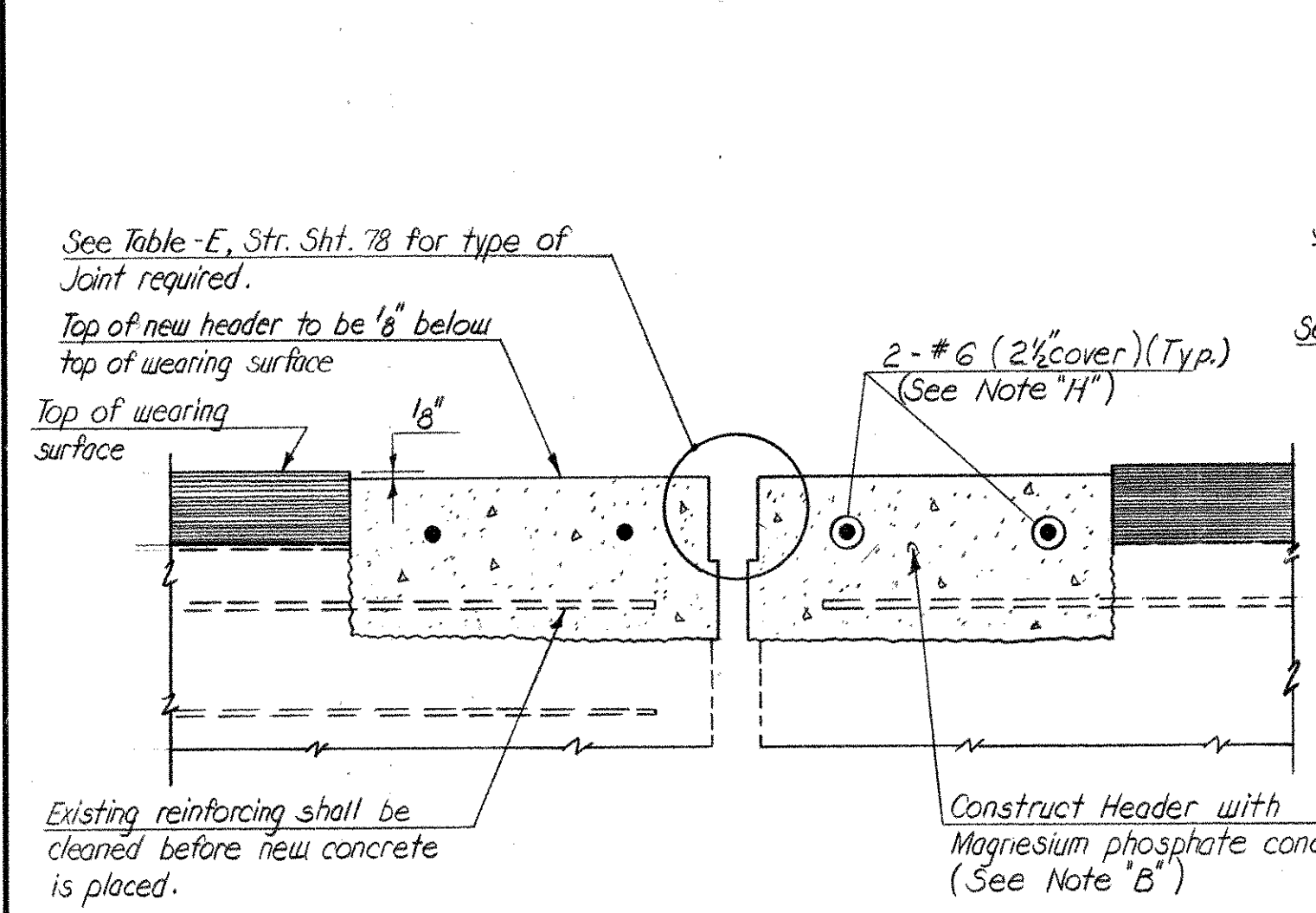

FINAL CONDITION
SECTION II-II
PREFERRED CONSTRUCTION
Headers Constructed After Placing Membrane & Overlay

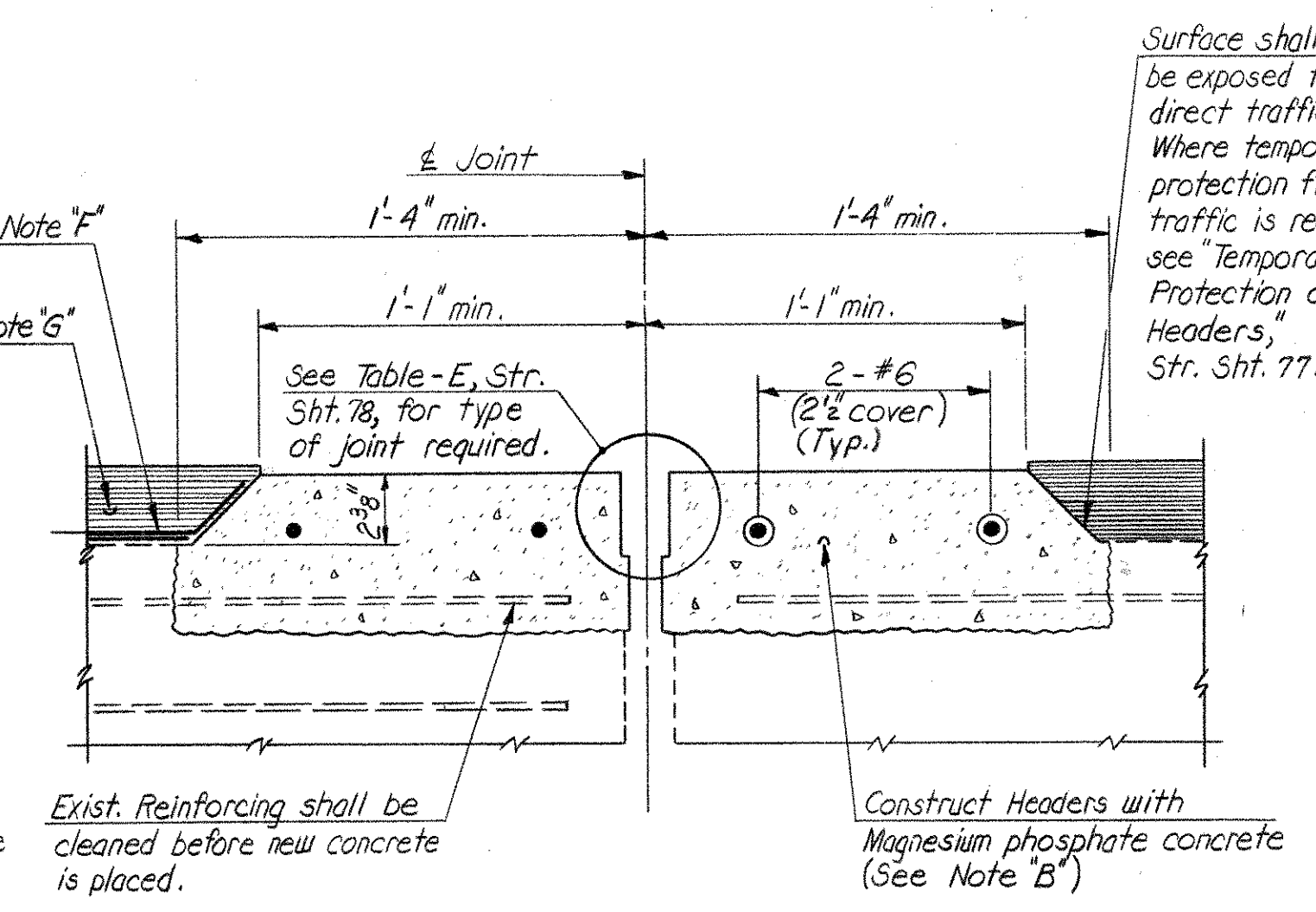

FINAL CONDITION
SECTION II-II
OPTIONAL CONSTRUCTION
Headers Constructed Prior to Placing Membrane & Overlay (SEE NOTE "E")

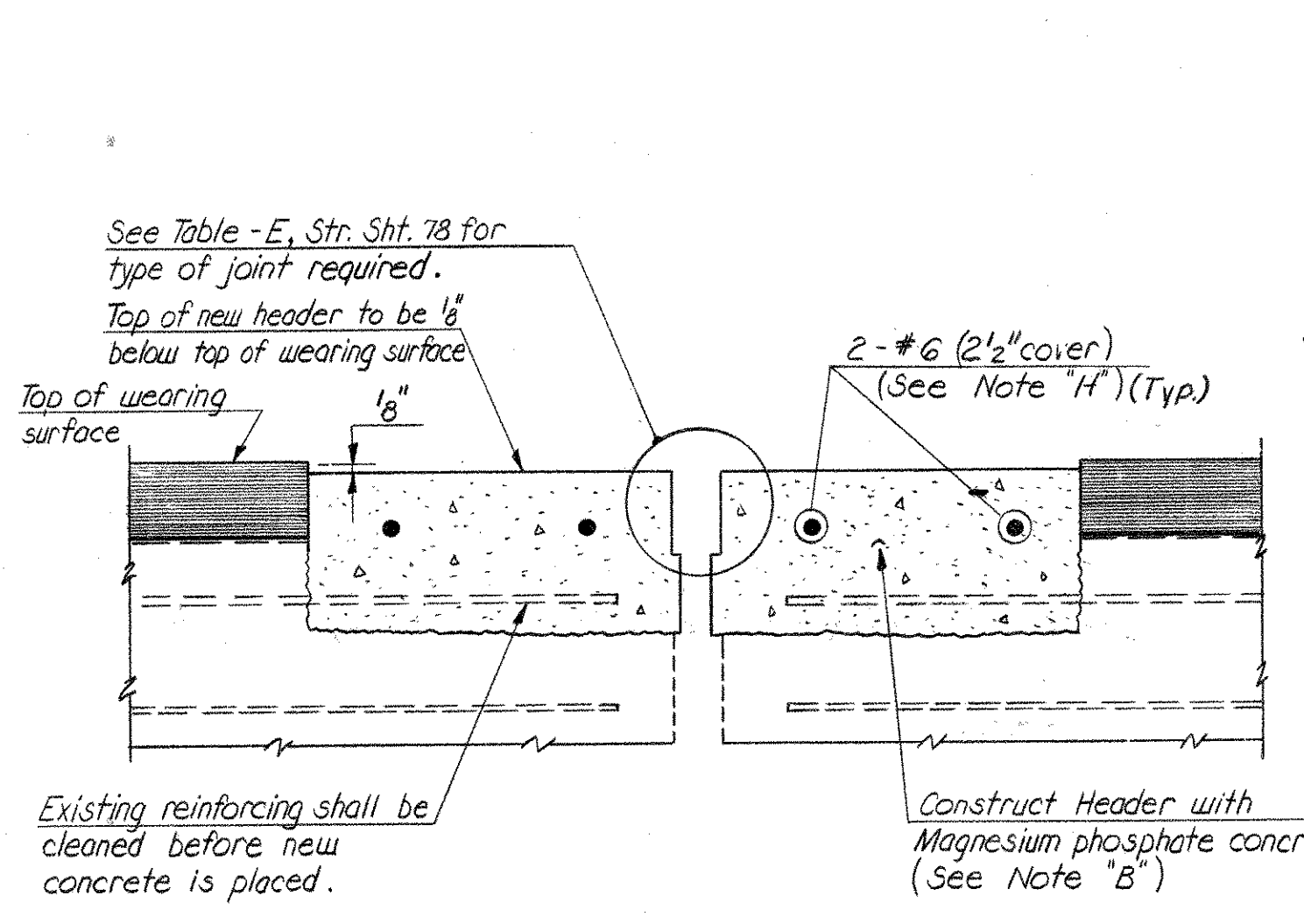

FINAL CONDITION
SECTION 12-12
PREFERRED CONSTRUCTION
Headers Constructed After Placing Membrane & Overlay

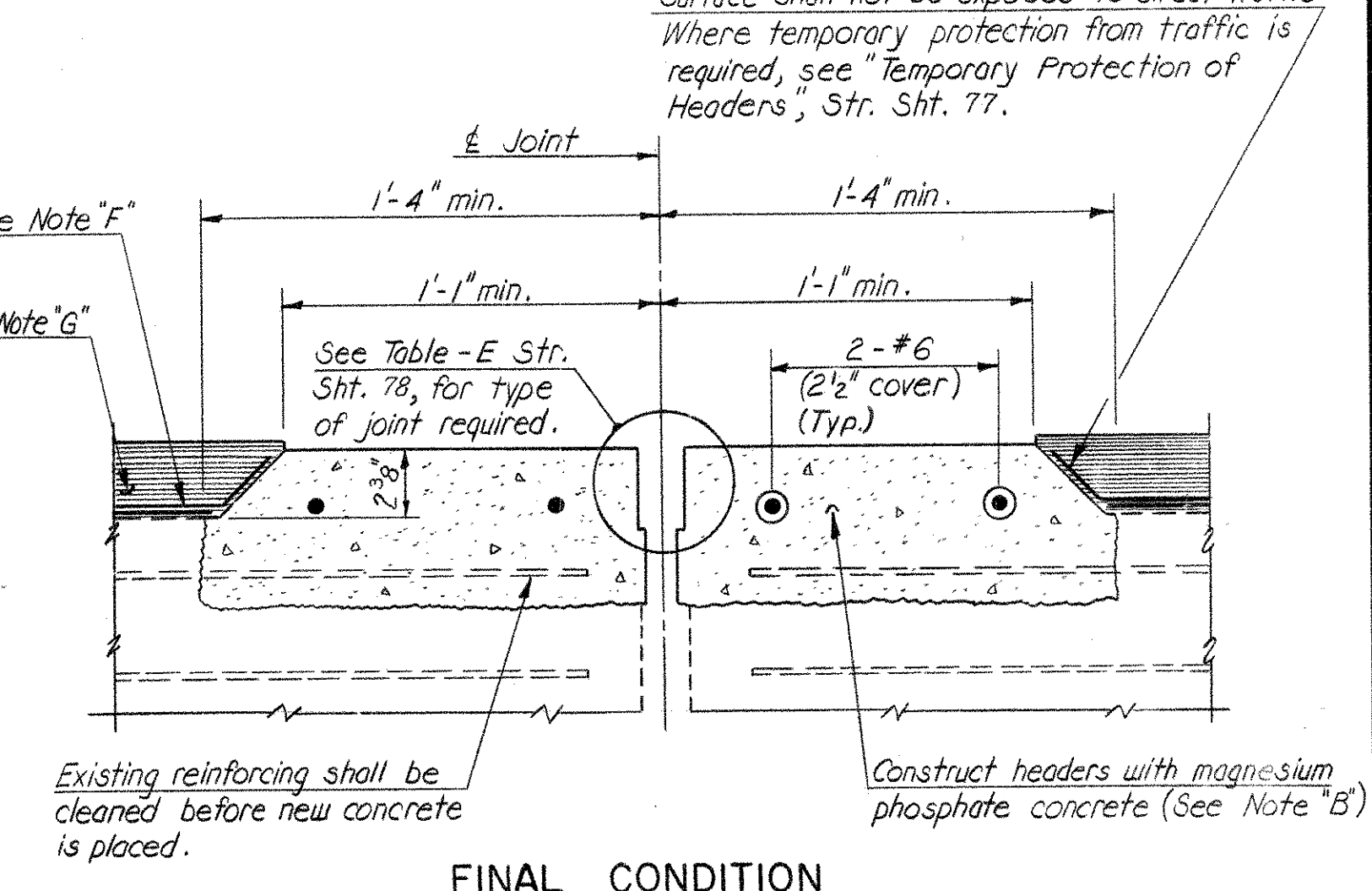

FINAL CONDITION
SECTION 12-12
OPTIONAL CONSTRUCTION
Headers Constructed Prior to Placing Membrane & Overlay (SEE NOTE "E")

Note A:
Place membrane waterproofing and wearing surface over existing joint. Then sawcut, remove and build the headers.

Note B:
See Special Provision for "Construct Concrete Headers".

Note C:
Horizontal limit of work to be done under item "Construct Concrete Headers".
See Special Provision "Construct Concrete Headers".

Note D:
Horizontal limit of work to be done under items "Partial Depth Patch" and "Full Depth Patch". All patches bordering this limit shall be completed before work is started under item "Construct Concrete Headers" (Typ.)

Note E:
This method of header construction shall only be used with the permission of the Engineer.

Note F:
Membrane Waterproofing. See General Notes for type.

Note G:
Bituminous Concrete Wearing Surface. See the General Notes.

Note H:
Reinforcing steel to be epoxy coated. See Special Provisions for "Construct Concrete Headers".

Surface shall not be exposed to direct traffic. Where temporary protection from traffic is required, see "Temporary Protection of Headers", Str. Sht. 77.

Surface shall not be exposed to direct traffic. Where temporary protection from traffic is required, see "Temporary Protection of Headers", Str. Sht. 77.

THE INFORMATION, INCLUDING ESTIMATED QUANTITIES OF WORK SHOWN ON THESE SHEETS IS BASED ON LIMITED INVESTIGATIONS BY THE STATE AND IS IN NO WAY WARRANTED TO INDICATE THE TRUE CONDITIONS OR ACTUAL QUANTITIES OR DISTRIBUTION OF QUANTITIES OF WORK WHICH WILL BE REQUIRED.

STATE OF CONNECTICUT			
DEPARTMENT OF TRANSPORTATION			
SOUTHINGTON-HARTFORD			
INTERSTATE RTE 84			
59 STRUCTURES			
DECK REPAIRS			
SECTIONS 11-11 AND 12-12			
ENGINEER BRIDGE DESIGN UNIT			
DESIGNER	G. J. A.	DRAFTER	J. J. C.
CHECKER	G. D. B.	DATE	3/17/82
APPROVED	<i>[Signature]</i>	BRIDGE LOG NO.	82 of 87
NO.	DATE	DESCRIPTION	STRUCTURE SHEET NO.
REVISIONS		STRUCTURE NO.	

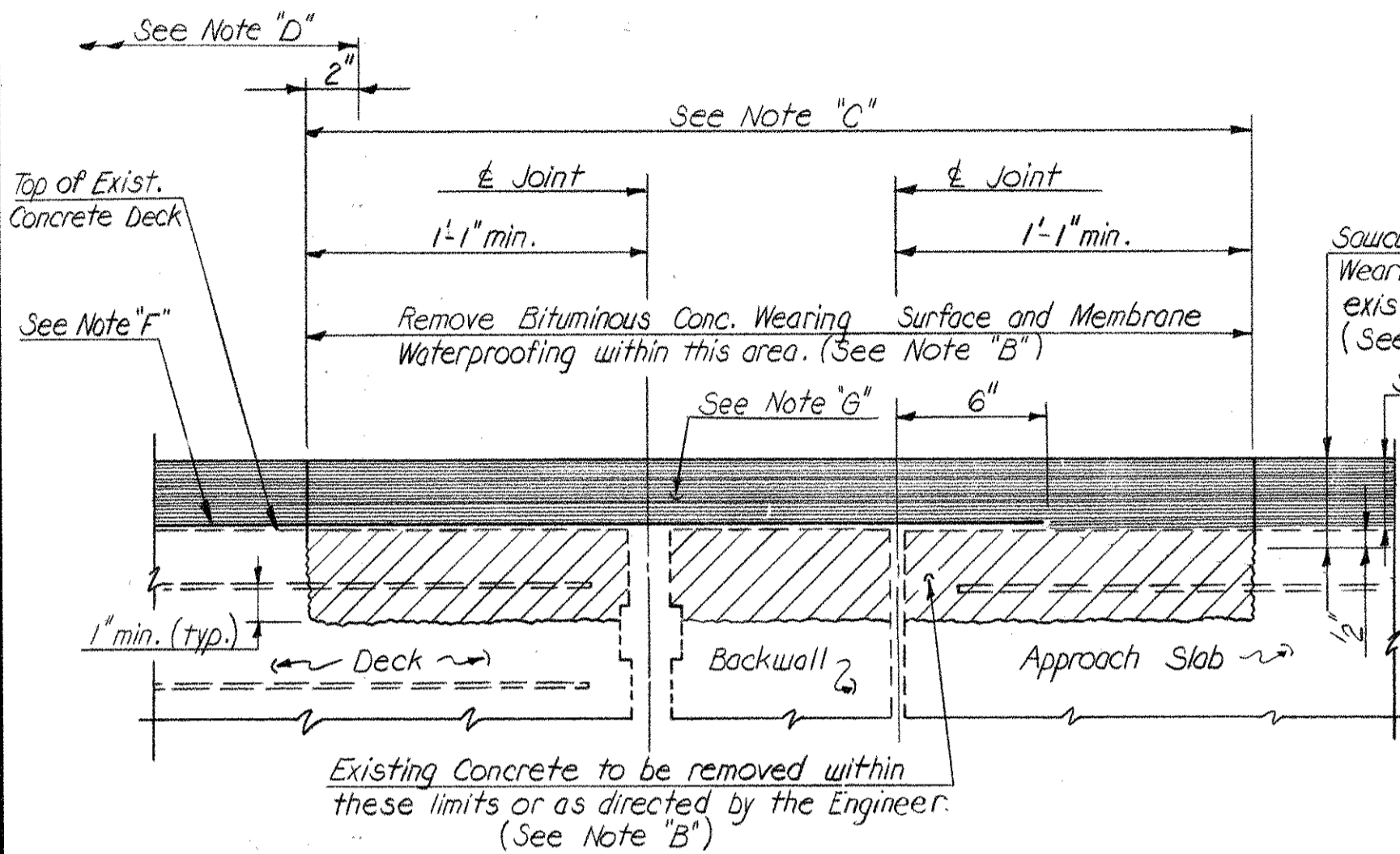

EXISTING CONDITION
Shown after placing wearing surface

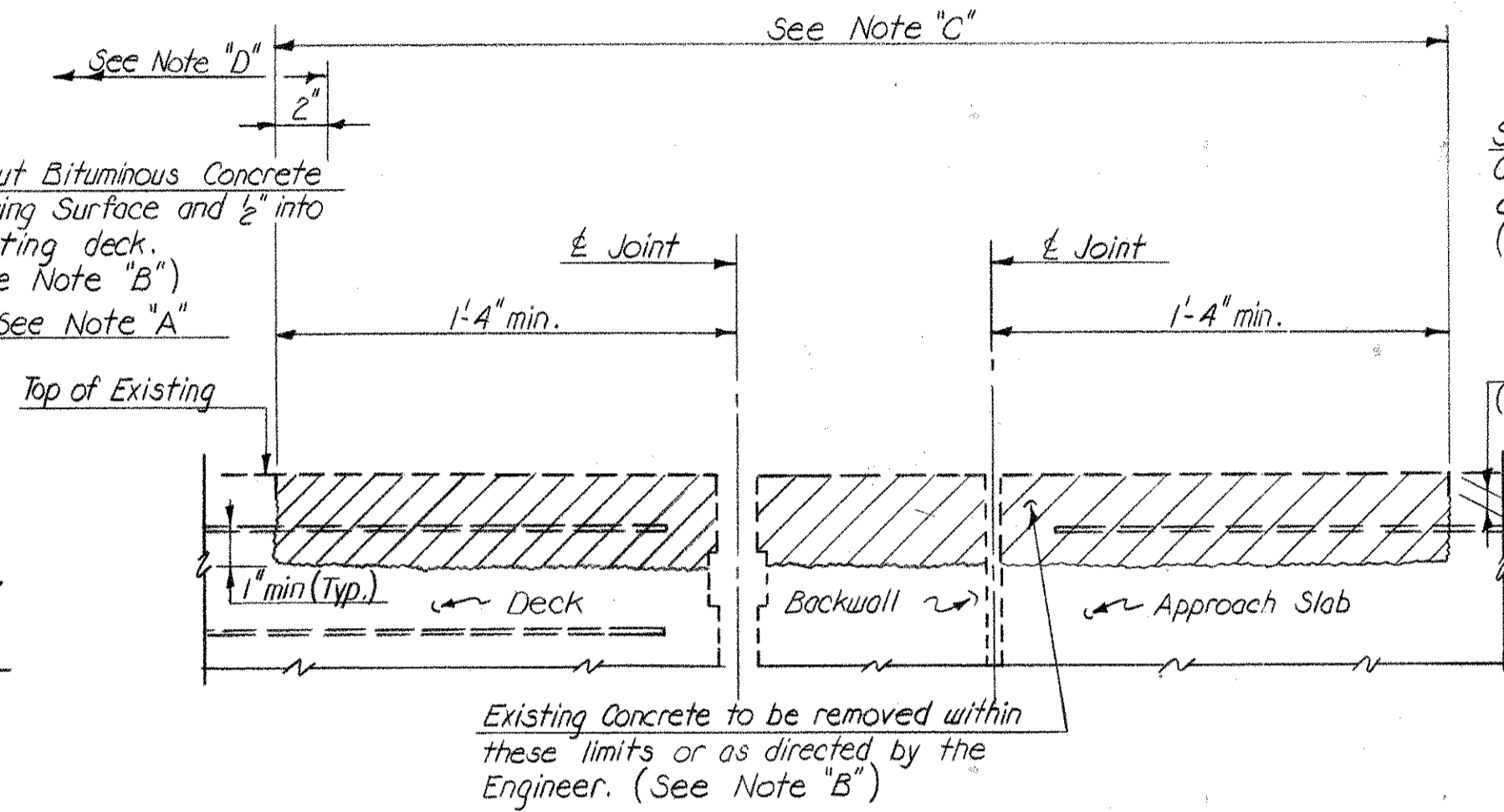

EXISTING CONDITION
Surface shall not be exposed to direct traffic. Where temporary protection from traffic is required, See "Temporary Protection of Headers", Str. Sht. 17.

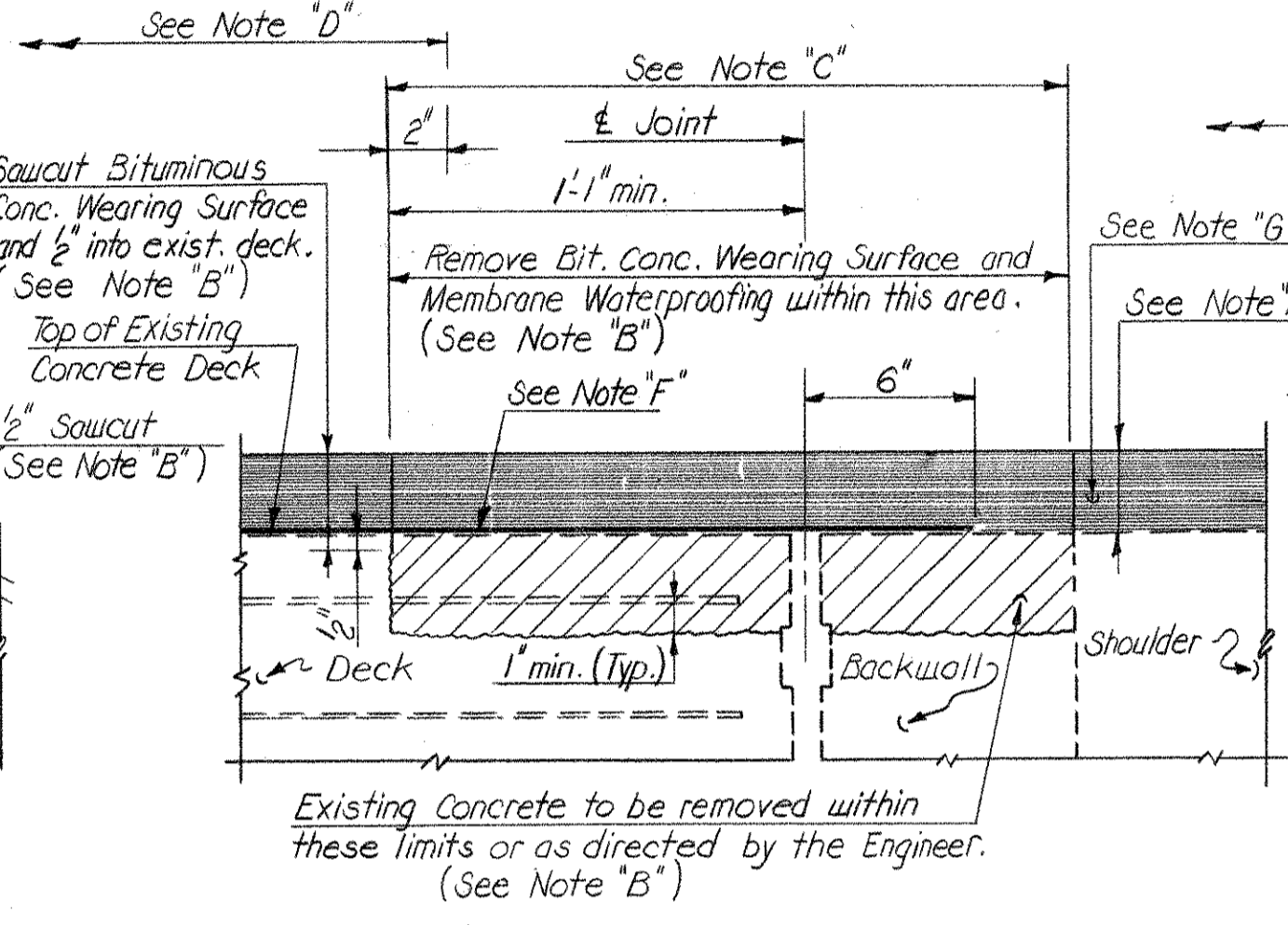

EXISTING CONDITION
Shown after placing wearing surface

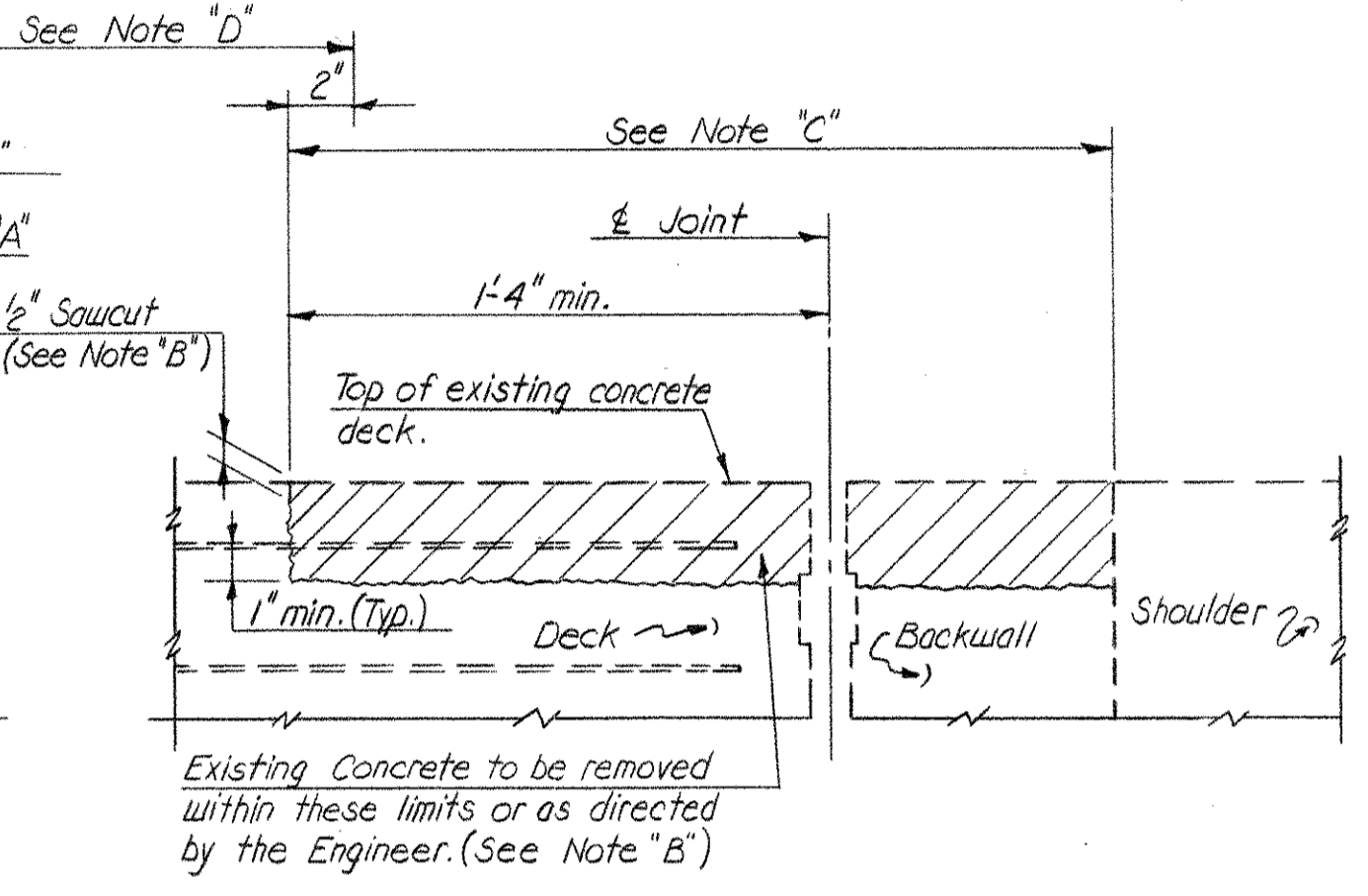

EXISTING CONDITION

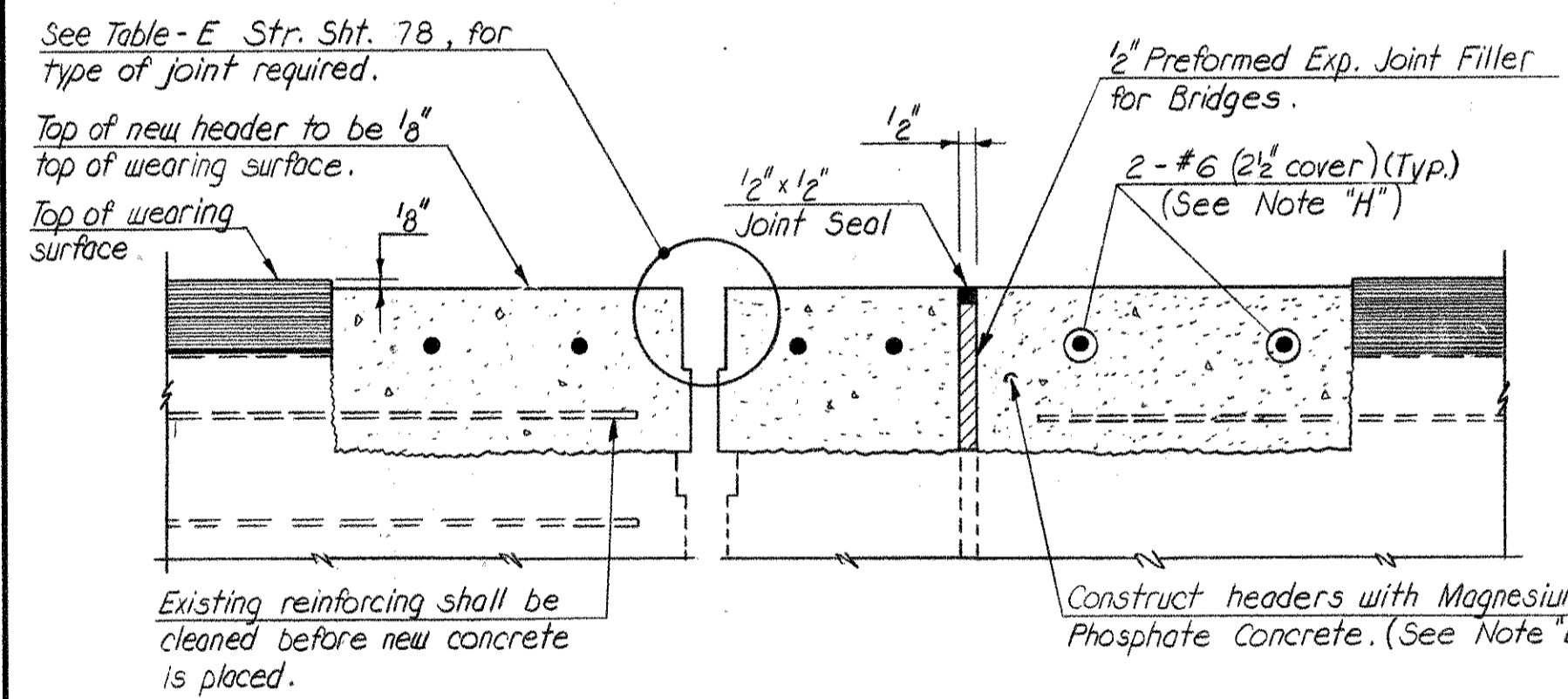

FINAL CONDITION
SECTION 13-13
PREFERRED CONSTRUCTION
Headers Constructed After Placing Membrane & Overlay

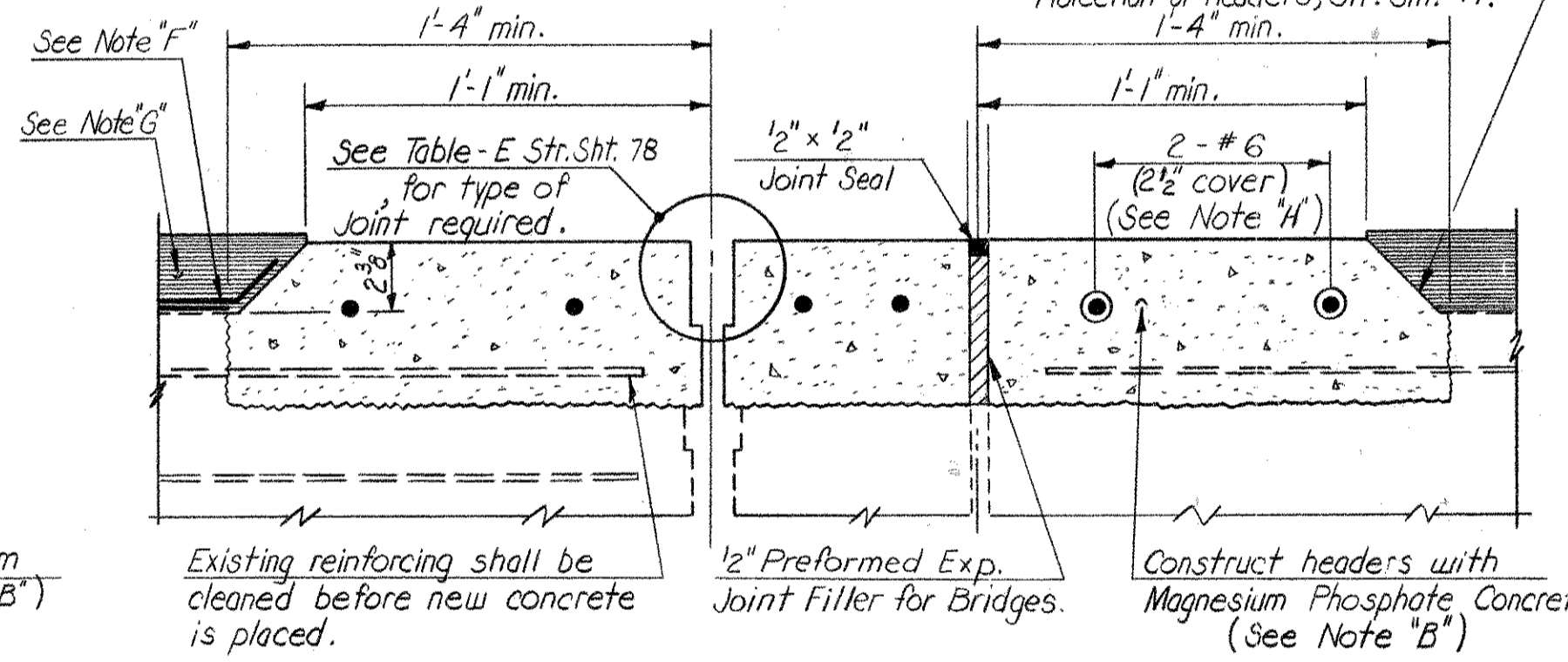

FINAL CONDITION
SECTION 13-13
OPTIONAL CONSTRUCTION
Headers Constructed Prior to Placing Membrane & Overlay (SEE NOTE "E")

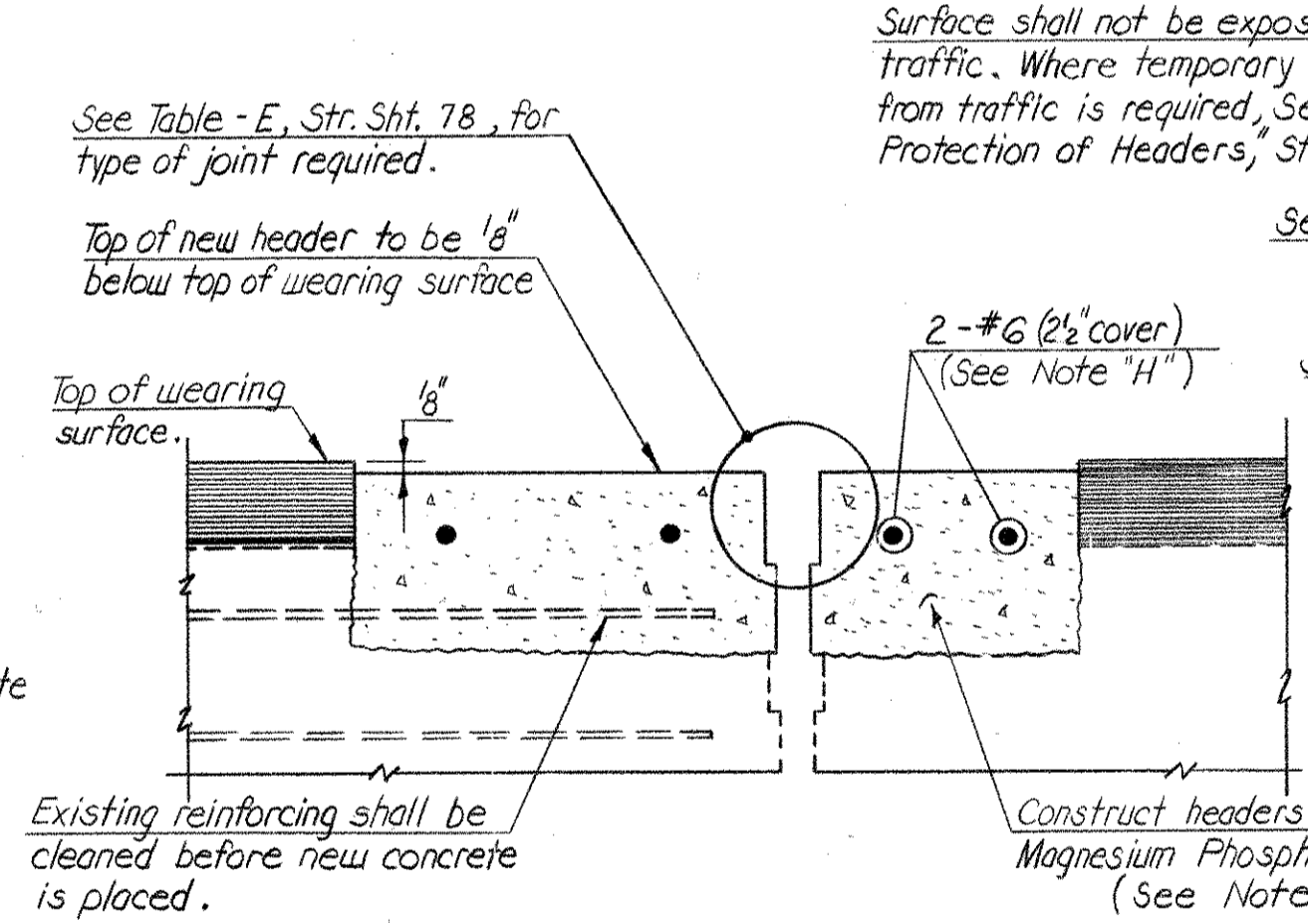

FINAL CONDITION
SECTION 14-14
PREFERRED CONSTRUCTION
Headers Constructed After Placing Membrane and Overlay

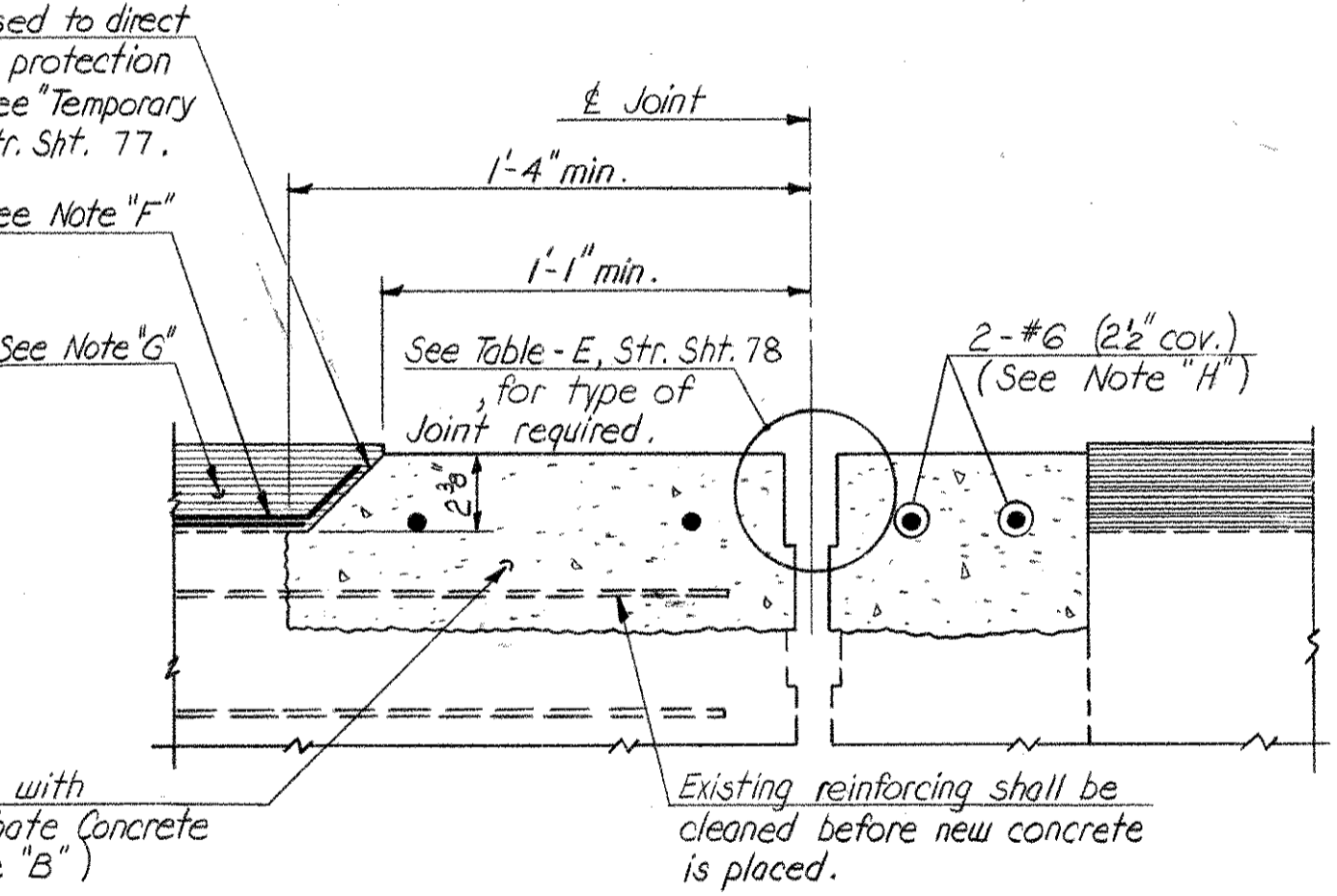

FINAL CONDITION
SECTION 14-14
OPTIONAL CONSTRUCTION *

Note A:
Place membrane waterproofing and wearing surface over existing joint. Then sawcut, remove and build the headers.

Note B:
See Special Provision for "Construct Concrete Headers".

Note C:
Horizontal limit of work to be done under item "Construct Concrete Headers".
See Special Provision "Construct Concrete Headers".

Note D:
Horizontal limit of work to be done under items "Partial Depth Patch" and "Full Depth Patch". All patches bordering this limit shall be completed before work is started under item "Construct Concrete Headers" (Typ.)

Note E:
This method of header construction shall only be used with the permission of the Engineer.

Note F:
Membrane Waterproofing. See General Notes for type.

Note G:
Bituminous Concrete Wearing Surface. See the General Notes.

Note H:
Reinforcing steel to be epoxy coated. See Special Provisions for "Construct Concrete Headers".

* Headers Constructed Prior to Placing Membrane & Overlay (SEE NOTE "E")

THE INFORMATION, INCLUDING ESTIMATED QUANTITIES OF WORK SHOWN ON THESE SHEETS IS BASED ON LIMITED INVESTIGATIONS BY THE STATE AND IS IN NO WAY WARRANTED TO INDICATE THE TRUE CONDITIONS OR ACTUAL QUANTITIES OR DISTRIBUTION OF QUANTITIES OF WORK WHICH WILL BE REQUIRED.

NO.	DATE	DESCRIPTION

STATE OF CONNECTICUT		
DEPARTMENT OF TRANSPORTATION		
SOUTHINGTON - HARTFORD		
INTERSTATE ROUTE 84		
59 STRUCTURES		
DECK REPAIRS		
SECTIONS 13-13 AND 14-14		
ENGINEER BRIDGE DESIGN UNIT		
DESIGNER G. J. A.	DRAFTER J. J. C.	CHECKER G. D. B.
APPROVED <i>[Signature]</i>	DATE 3/17/82	
STRUCTURE NO.	BRIDGE LOG NO.	STRUCTURE SHEET NO.
		83 of 87

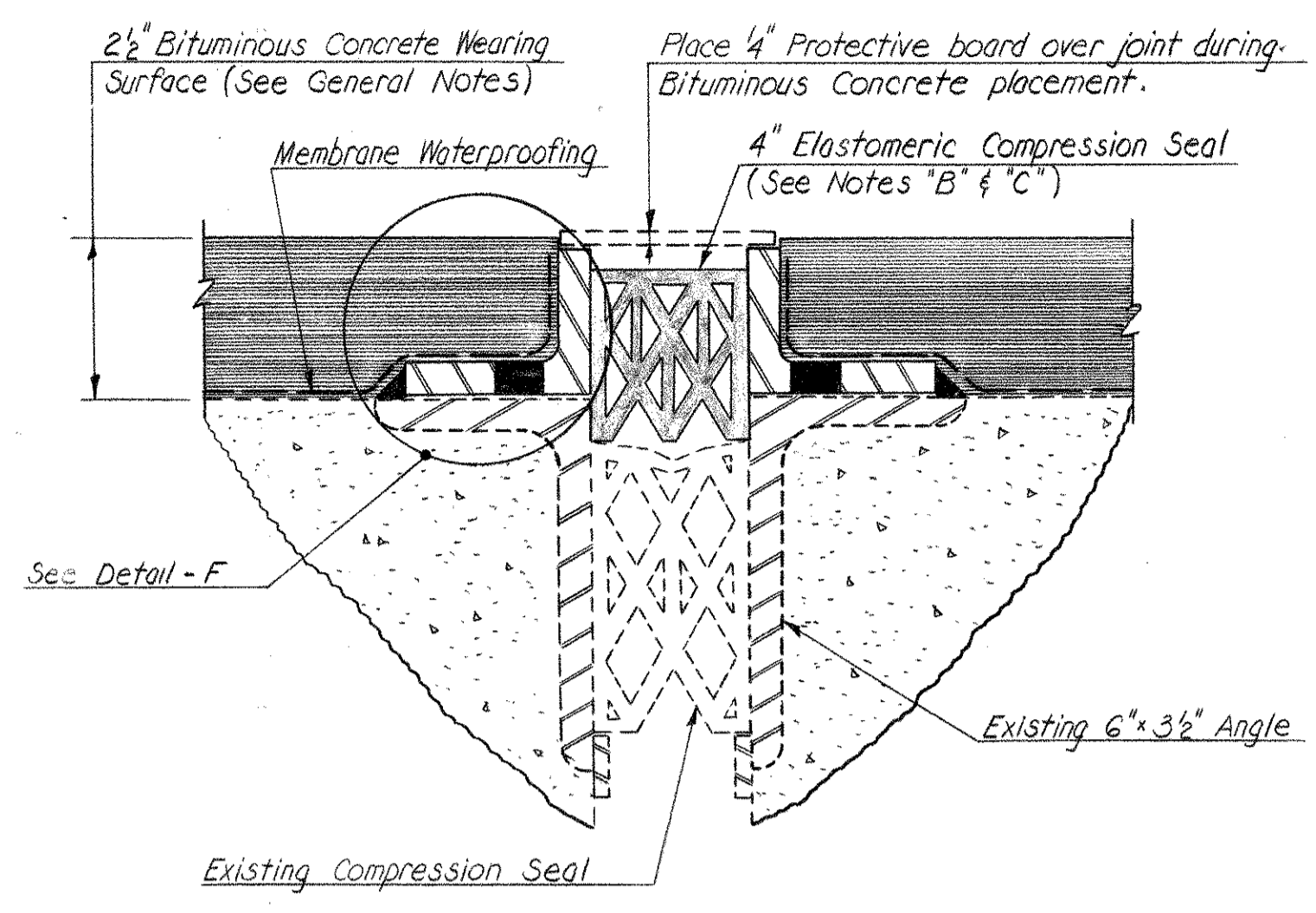

SECTION 6-6
 Scale: 3/8"=1'-0"

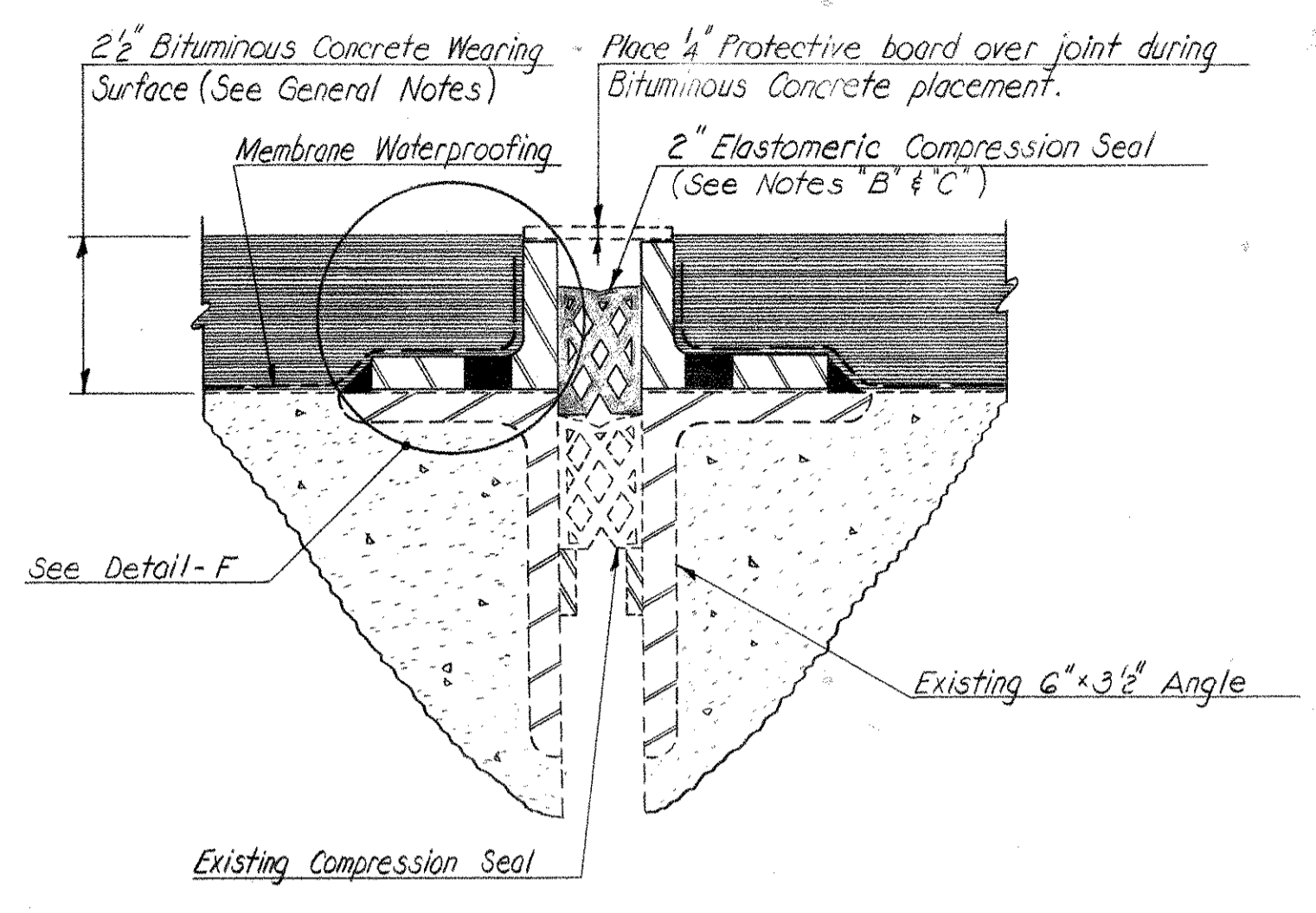

SECTION 7-7
 Scale: 3/8"=1'-0"

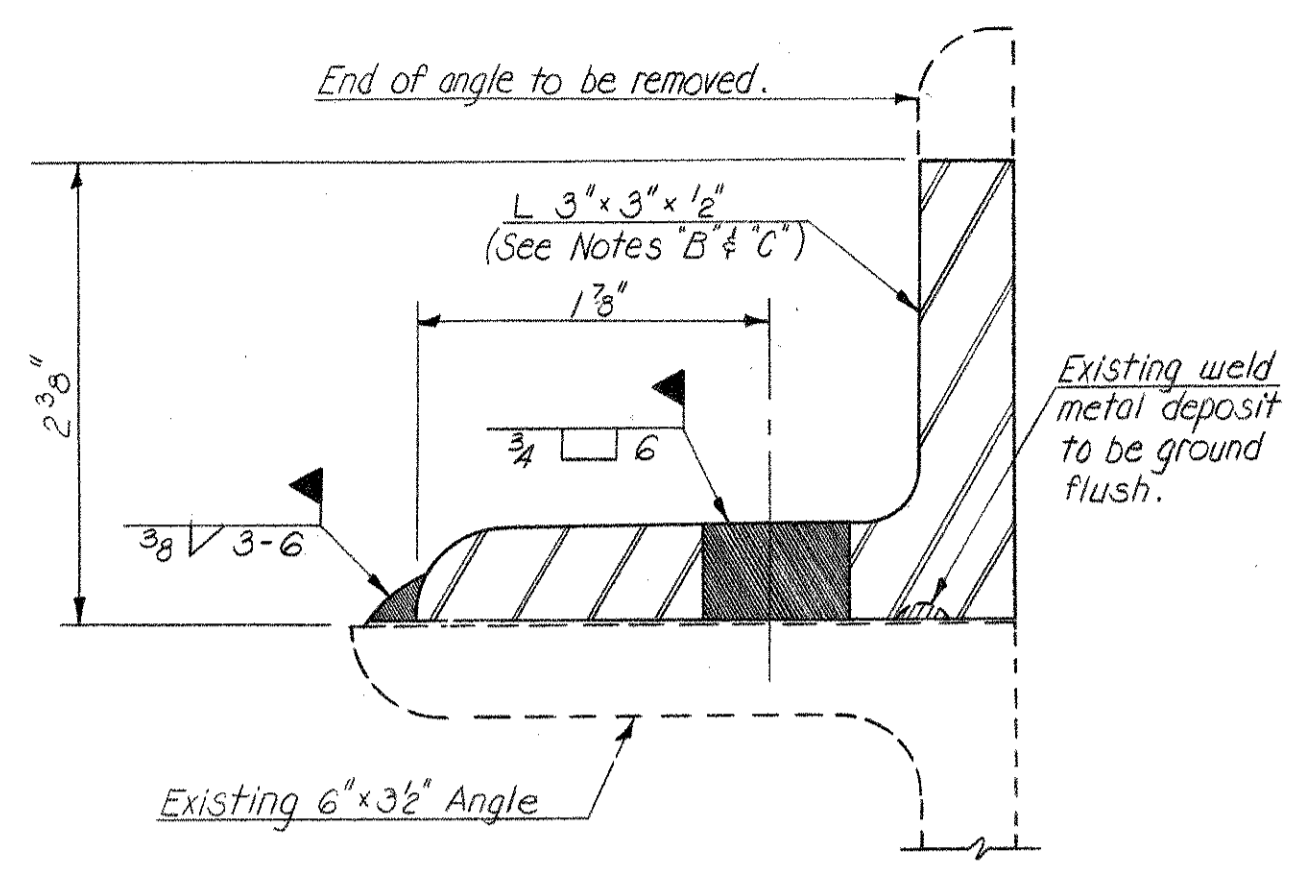

DETAIL - F
 Scale: Full Size

- NOTES**
- A: All data shown in Table - D and information showing existing conditions was taken from the original contract plans. The contractor shall verify all data before fabrication of the new joint components.
 - B: The cost of furnishing and installing angles and Elastomeric Compression Seals shall be included in the items for "Modification of Armored Compression Seal (2")" and "Modification of Armored Compression Seal (4")".
 - C: Angles shall be installed in continuous lengths wherever possible, joints shall be held to a minimum, consistent with the requirements of "Maintenance and Protection of Traffic and field conditions". The Elastomeric Compression Seals shall be installed in one continuous length gutter to gutter on each joint.
 - D: Temporary protection of Joints shall be provided as shown on "Temporary Protection of Header", str. sh. 77.

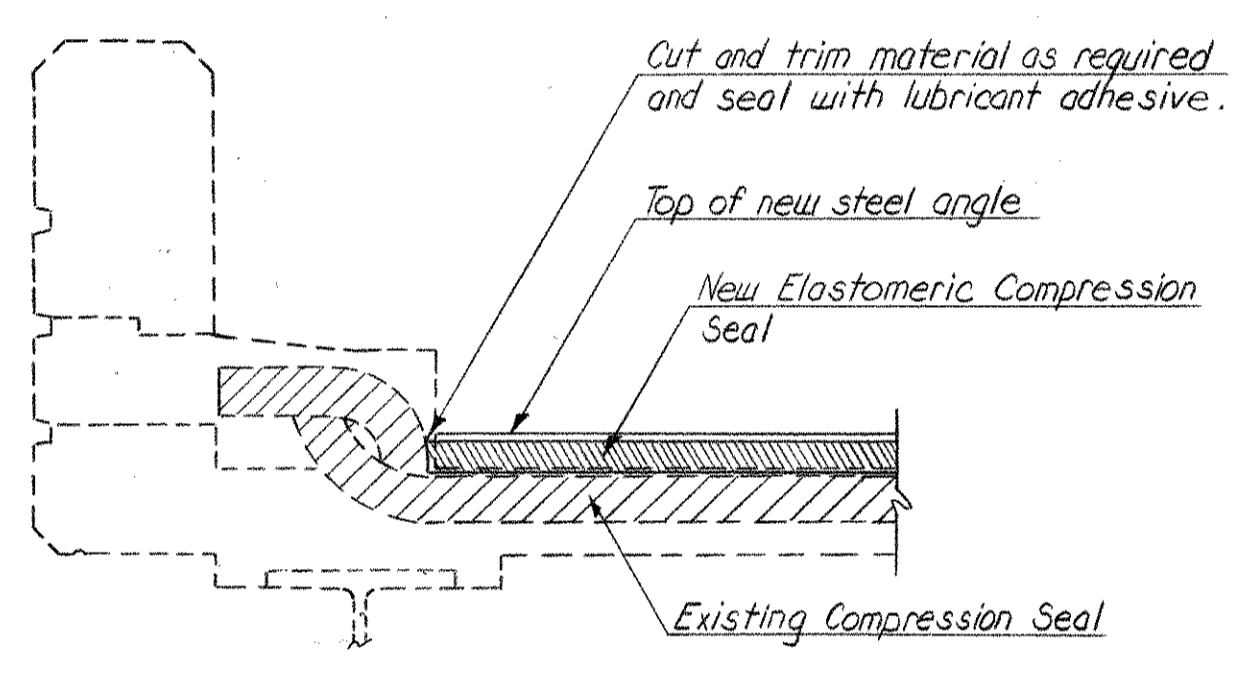

DETAIL - G
 Limits of Elastomeric Compression Seal

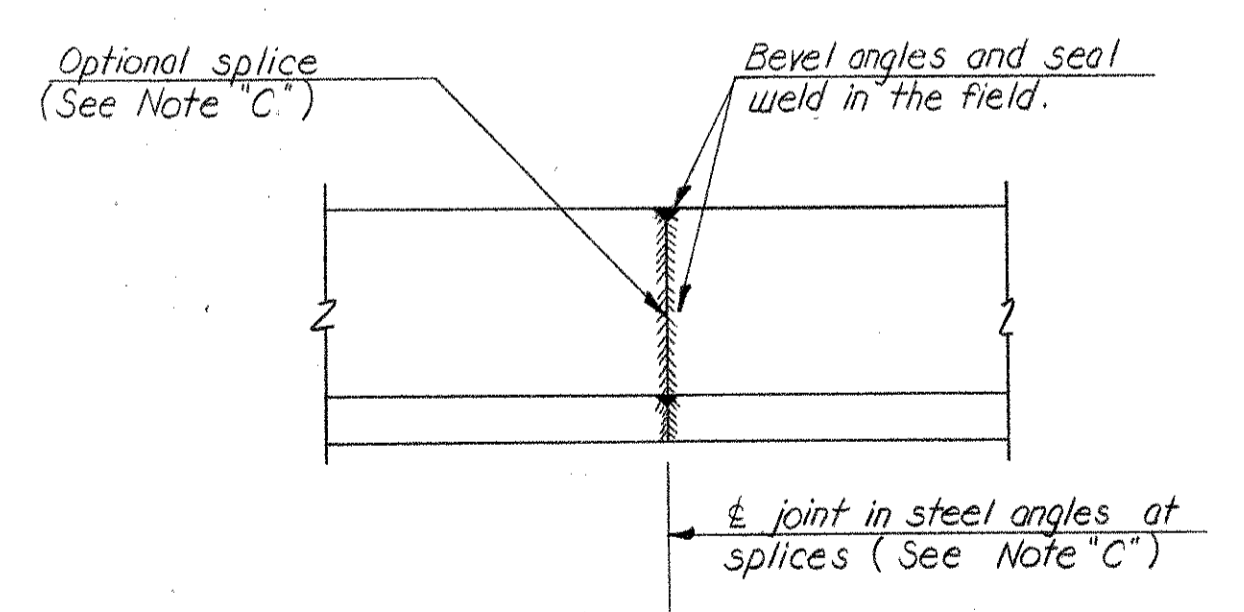

ANGLE SPLICE DETAIL

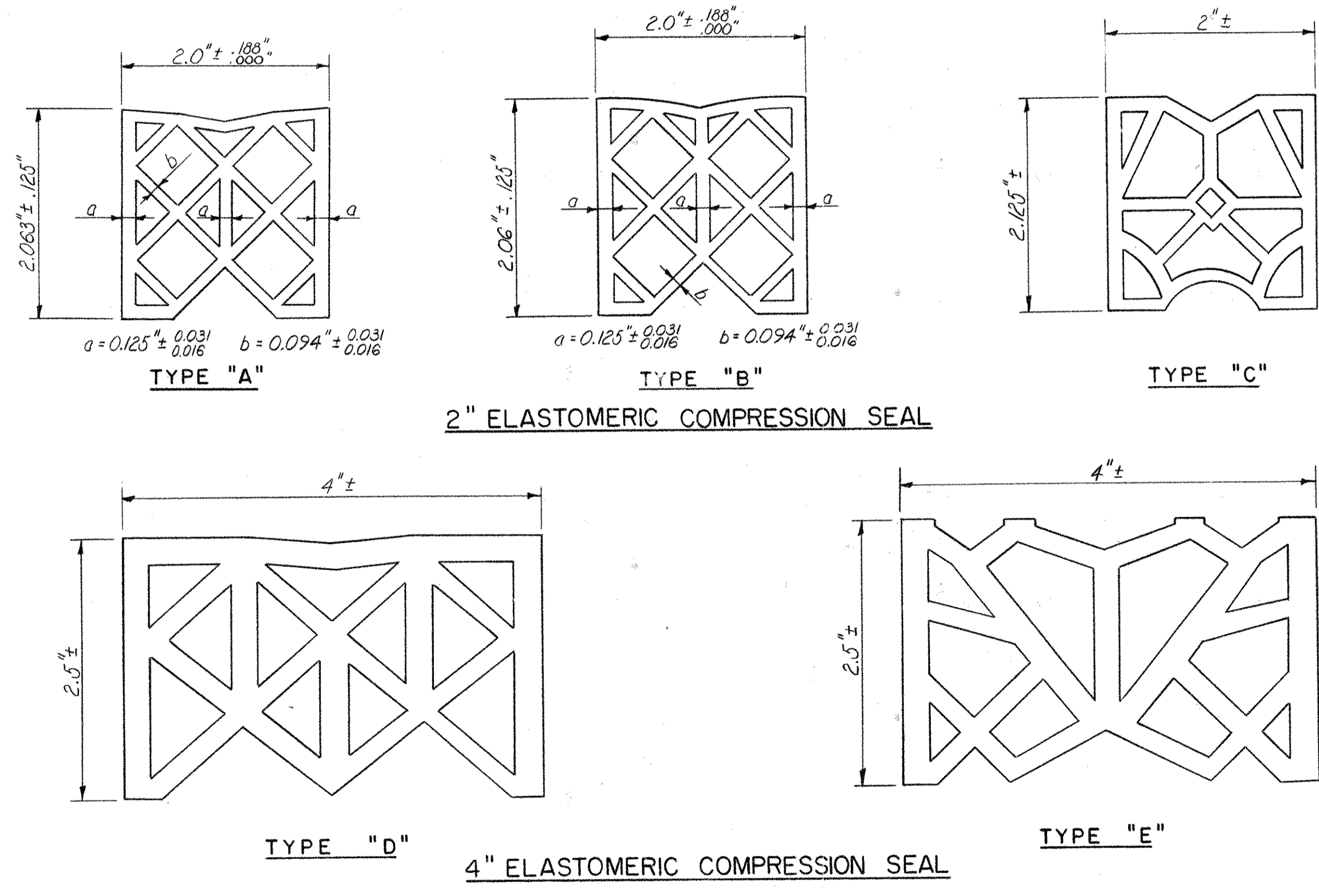

TABLE - D (SEE NOTE "A")

Bridge Number	Location	Skew \angle	Size of Compression Seal	Joint Length Gutter to Gutter	Refer to Structure Sheet #
3311	Pier # 1	0°	4"	50'	17
"	Pier # 2	0°	4"	50'	17
"	Pier # 3	0°	2"	50'	17
"	Pier # 4	0°	4"	50'	18
"	Pier # 5	0°	4"	50'	18
3312	Pier # 1	0°	4"	50'	19
"	Pier # 2	0°	2"	50'	19
"	Pier # 3	0°	4"	50'	19 & 20
"	Pier # 4	0°	4"	50'	20
"	Pier # 5	0°	4"	50'	20
"	Pier # 6	0°	4"	50'	20 & 21
"	Pier # 7	0°	4"	50'	21
3313	Pier # 1	0°	2"	26'	22
"	Pier # 2	0°	4"	26'	22
"	Pier # 3	0°	4"	26'	22
"	Pier # 4	0°	4"	26'	22 & 23
"	Pier # 5	0°	4"	26'	23
"	Pier # 6	0°	4"	26'	23
"	Pier # 7	0°	4"	26'	23
"	Pier # 8	0°	4"	26'	23
3320	Pier # 1	0°	4"	26'	24
"	Pier # 2	0°	4"	26'	24

STATE OF CONNECTICUT
 DEPARTMENT OF TRANSPORTATION
 SOUTHINGTON - HARTFORD
 INTERSTATE ROUTE 84
 59 STRUCTURES
 DECK REPAIRS
 MODIFICATION OF ARMORED COMPRESSION SEALS

ENGINEER BRIDGE DESIGN UNIT
 DESIGNER G.J.A. DRAFTER J.J.C. CHECKER G.D.B.
 APPROVED [Signature] DATE 3/17/82
 NO. DATE DESCRIPTION STRUCTURE NO. BRIDGE LOG NO. STRUCTURE SHEET NO.
 REVISIONS 84 OF 87

THE INFORMATION, INCLUDING ESTIMATED QUANTITIES OF WORK SHOWN ON THESE SHEETS IS BASED ON LIMITED INVESTIGATIONS BY THE STATE AND IS IN NO WAY WARRANTED TO INDICATE THE TRUE CONDITIONS OR ACTUAL QUANTITIES OR DISTRIBUTION OF QUANTITIES OF WORK WHICH WILL BE REQUIRED.

F.W.A. REGION	STATE	TOWN	FED. AID PROJ. NO.	PROJ. NO.	YEAR	ROUTE NO.	SHEET NO.	TOTAL SHEETS
1	CONN.	Southington-Hartford	F1R04-3(55)A2	131-145	1982	I-84	98	115

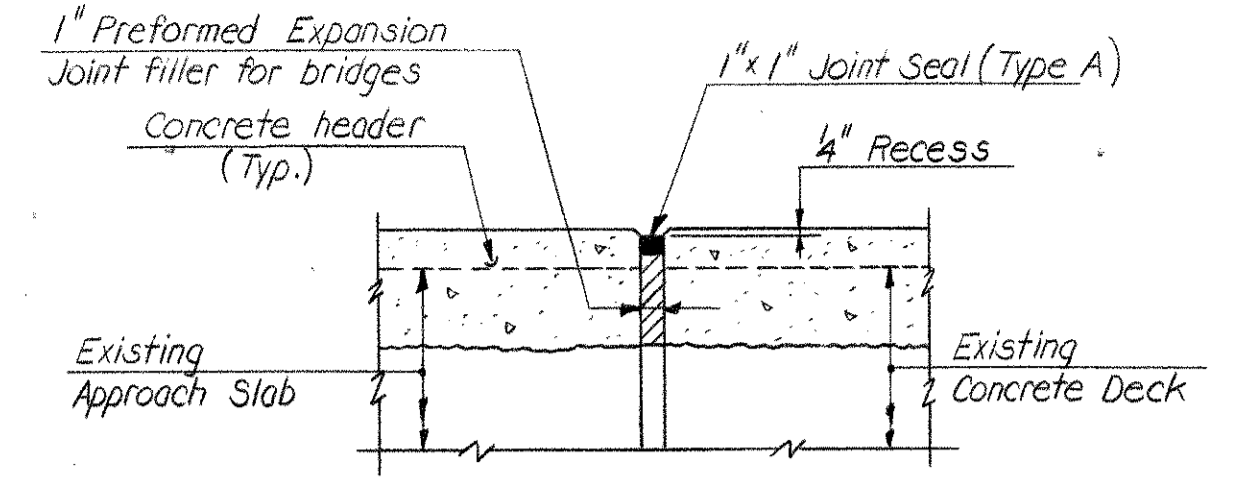

SECTION 15-15
Scale: 1"=1'-0"

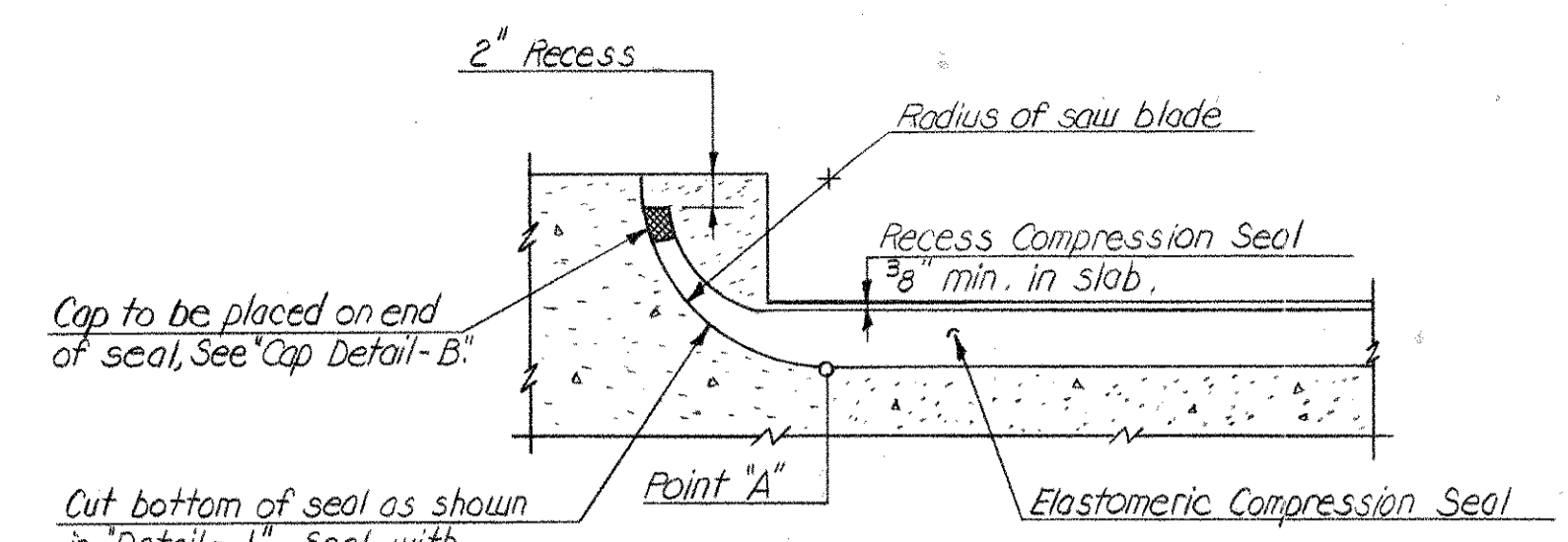

SECTION 17-17
Scale: 1"=1'-0"

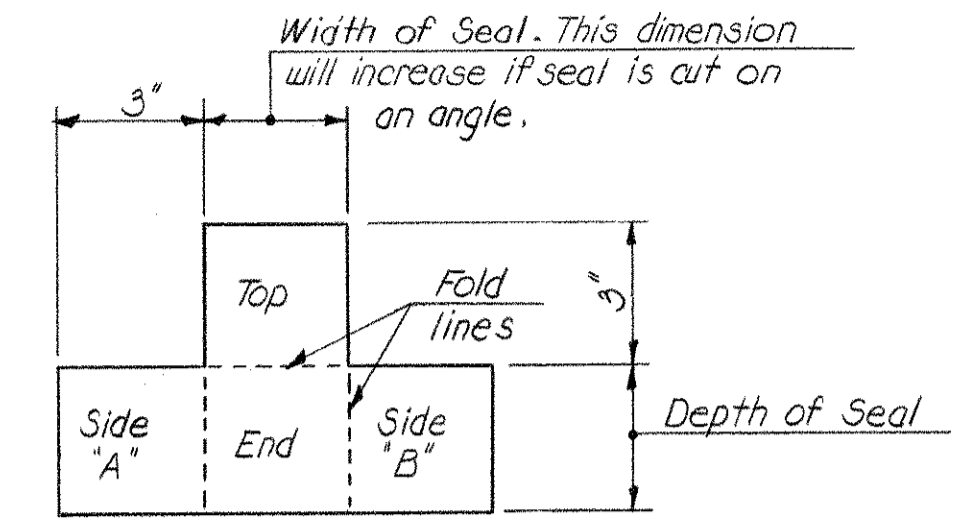

CAP DETAIL - A

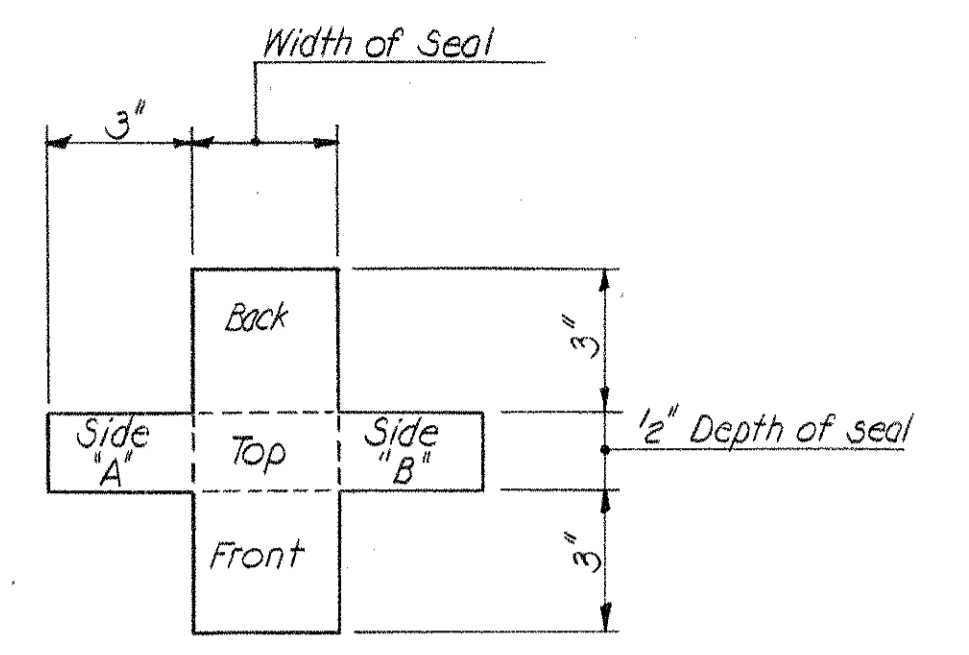

CAP DETAIL - B

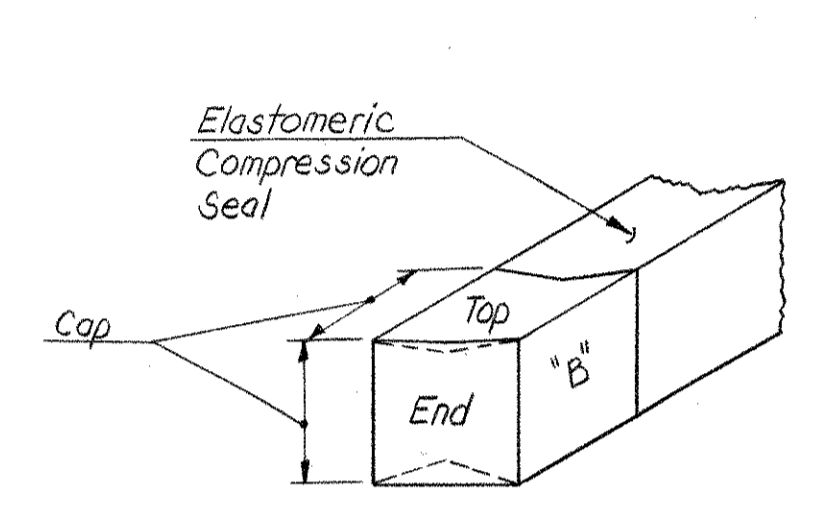

ISOMETRIC VIEW OF CAP

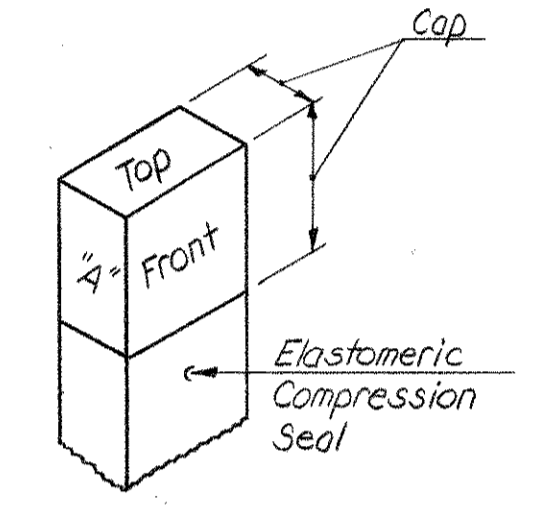

ISOMETRIC VIEW OF CAP

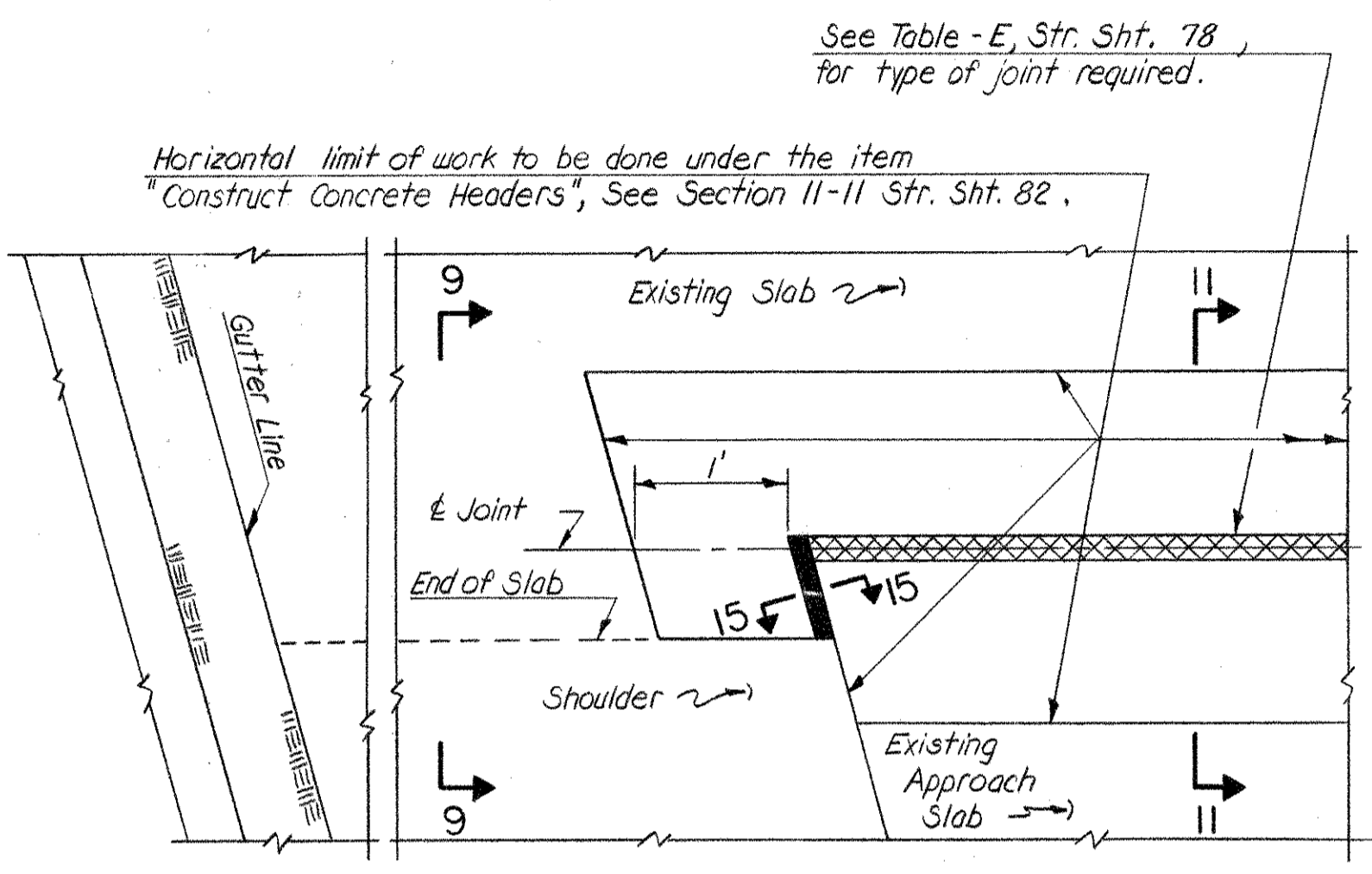

PLAN FOR HEADER AND JOINT TREATMENT AT ABUTMENTS
Scale: 1"=1'-0"

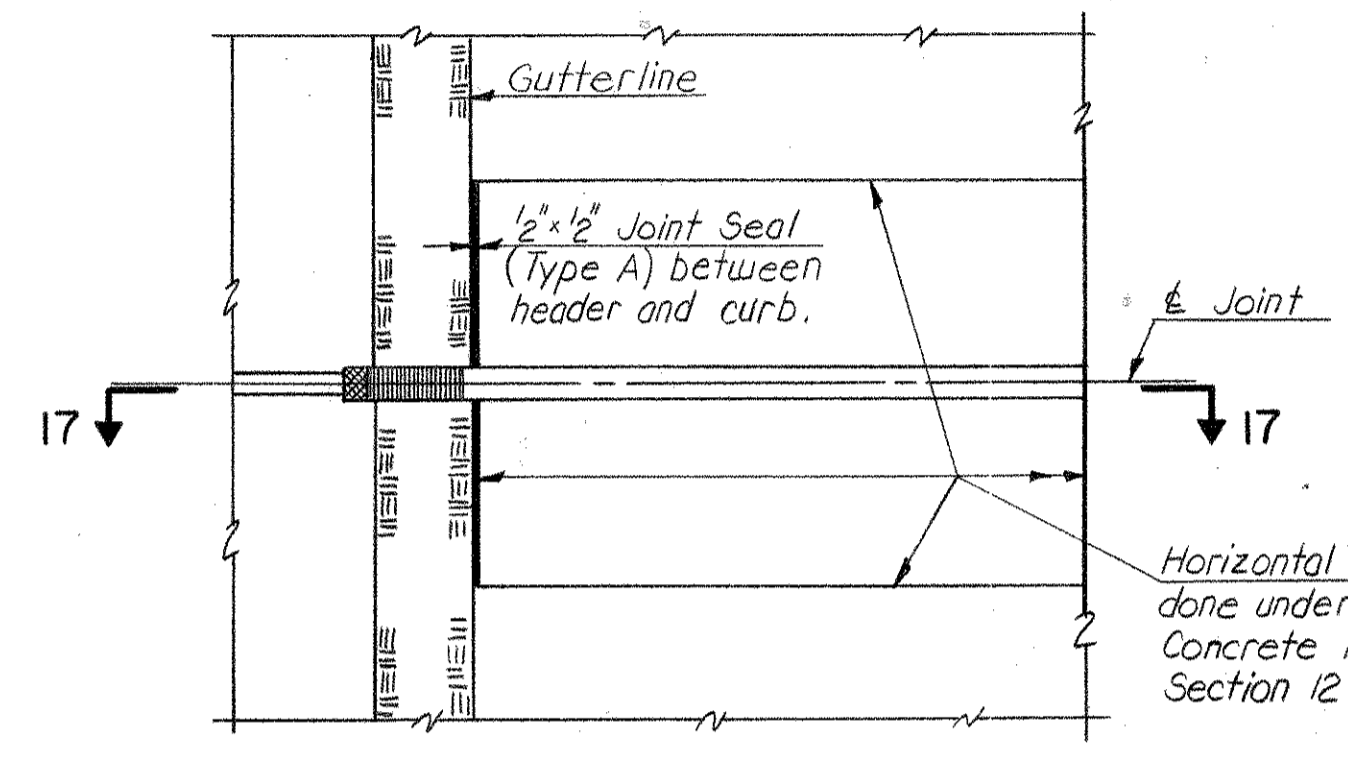

ELASTOMERIC COMPRESSION SEAL TREATMENT AT CURB
(Deck and Parapet Joints aligned at curb.)
Scale: 1"=1'-0"

Horizontal limit of work to be done under item "Construct Concrete Headers" See Section 12-12, Str. Sht. 82.

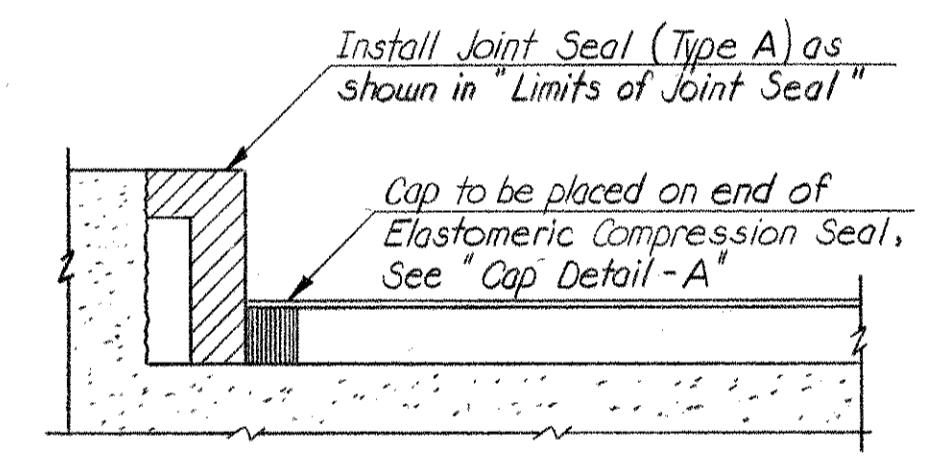

SECTION 16-16
Scale: 1"=1'-0"

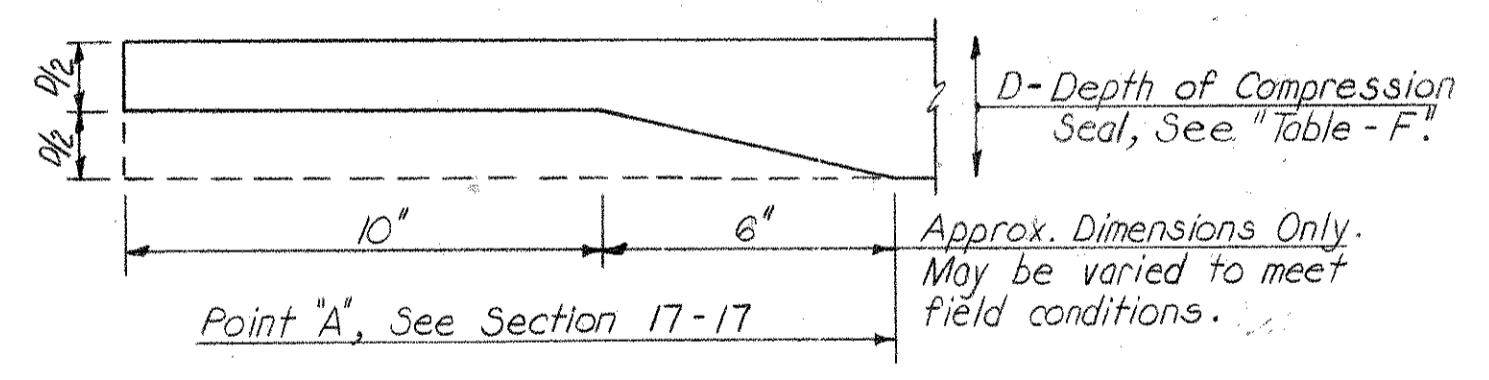

DETAIL - J
Not to Scale

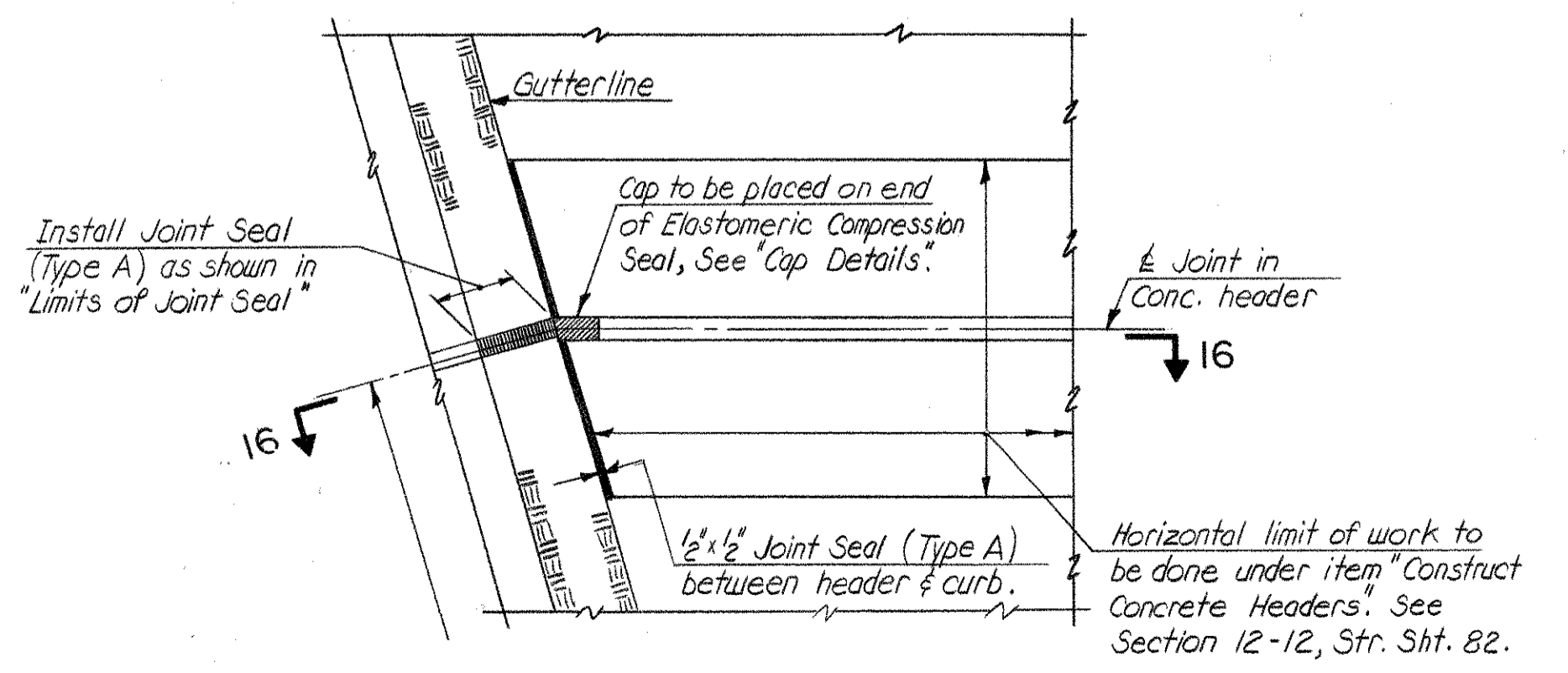

ELASTOMERIC COMPRESSION SEAL TREATMENT AT CURB
(Deck and Parapet Joints not aligned at curb)
Scale: 1"=1'-0"

CAP DETAIL NOTES

Material for Cap to be 1/8" thick 50 Durometer Neoprene Sheet, cut a "T" Shape Section as shown in Cap Detail.
Prepare End of the Seal by cutting to desired angle and clean with a solvent as recommended by the manufacturer. Clean the Neoprene Cap in the same manner.
Apply the Cap adhesive, recommended by the manufacturer to the Neoprene Cap as shown in Cap Detail.
Position and place cover onto the seal end and hold firmly for approximately 5 minutes.
Check to see that all corners and edges have bonded securely to seal. If not, add adhesive as required and hold until bonded. The cap shall be water tight.
After approximately ten (10) minutes, the seal may be installed into the bridge joint.

STATE OF CONNECTICUT			
DEPARTMENT OF TRANSPORTATION			
SOUTHINGTON - HARTFORD			
INTERSTATE RTE. 84			
59 STRUCTURES			
DECK REPAIRS			
JOINT DETAILS - I			
ENGINEER BRIDGE DESIGN UNIT		CHECKER G.D.B.	
DESIGNER G.J.A.	DRAFTER J.J.C.	DATE 3/17/82	
APPROVED <i>[Signature]</i>	BRIDGE LOG NO. STRUCTURE SHEET NO.		
NO. DATE DESCRIPTION		STRUCTURE NO.	85 of 87
REVISIONS			

THE INFORMATION, INCLUDING ESTIMATED QUANTITIES OF WORK SHOWN ON THESE SHEETS IS BASED ON LIMITED INVESTIGATIONS BY THE STATE AND IS IN NO WAY WARRANTED TO INDICATE THE TRUE CONDITIONS OR ACTUAL QUANTITIES OR DISTRIBUTION OF QUANTITIES OF WORK WHICH WILL BE REQUIRED.

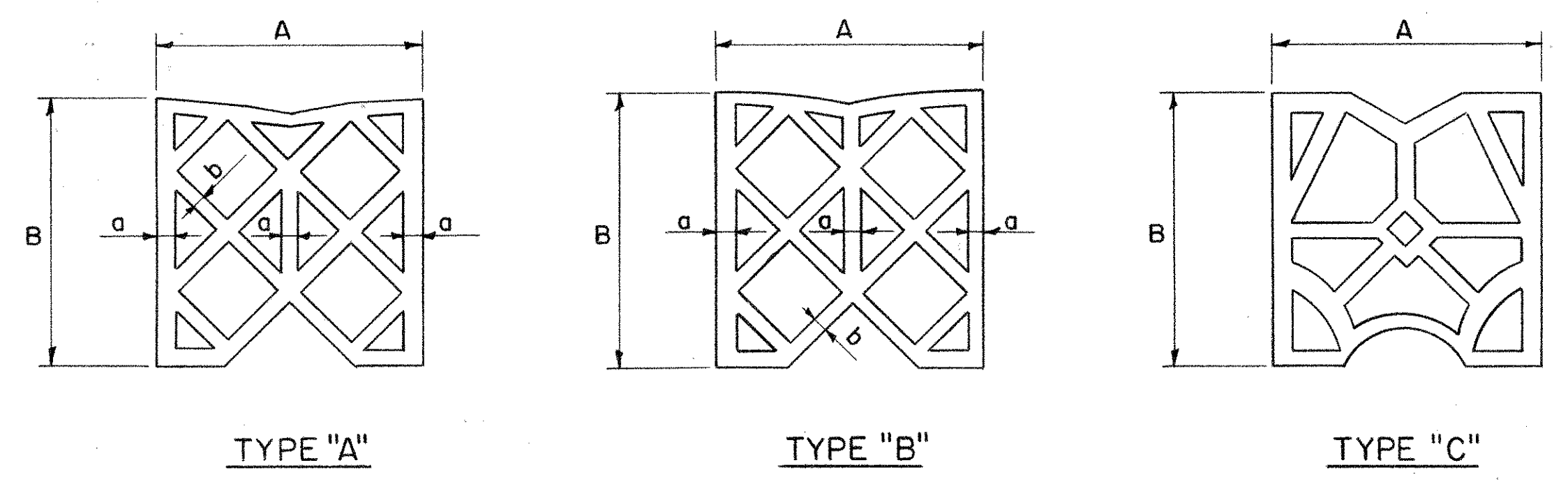

TYPE "A"				TYPE "B"				TYPE "C"				
Nominal Width	A	B	Thickness	A	B	a	b	A	B	a	b	
			a				b				a	b
2"	2.0 ^{+0.188} _{-0.000}	2.063 ^{+0.125} _{-0.016}	.125 ^{+0.031} _{-0.016}	.094 ^{+0.031} _{-0.016}	2.0 ^{+0.188} _{-0.000}	2.063 ^{+0.125} _{-0.016}	.125 ^{+0.031} _{-0.016}	.094 ^{+0.031} _{-0.016}	2.0 ^{+0.188} _{-0.000}	2.125 ^{+0.047} _{-0.016}	—	—
3"	3.0 ^{+0.250} _{-0.000}	3.406 ^{+0.188} _{-0.016}	.188 ^{+0.047} _{-0.016}	.125 ^{+0.047} _{-0.016}	3.0 ^{+0.250} _{-0.000}	3.375 ^{+0.188} _{-0.016}	.188 ^{+0.047} _{-0.016}	.125 ^{+0.047} _{-0.016}	3.0 ^{+0.250} _{-0.000}	3.315 ^{+0.047} _{-0.016}	—	—
4"	4.0 ^{+0.250} _{-0.000}	4.719 ^{+0.250} _{-0.031}	.250 ^{+0.047} _{-0.016}	.188 ^{+0.047} _{-0.016}	4.0 ^{+0.250} _{-0.000}	4.375 ^{+0.250} _{-0.016}	.250 ^{+0.047} _{-0.016}	.188 ^{+0.047} _{-0.016}	4.0 ^{+0.250} _{-0.000}	4.625 ^{+0.047} _{-0.016}	—	—

Note: Configuration of interior ribs may vary.

ELASTOMERIC COMPRESSION SEAL

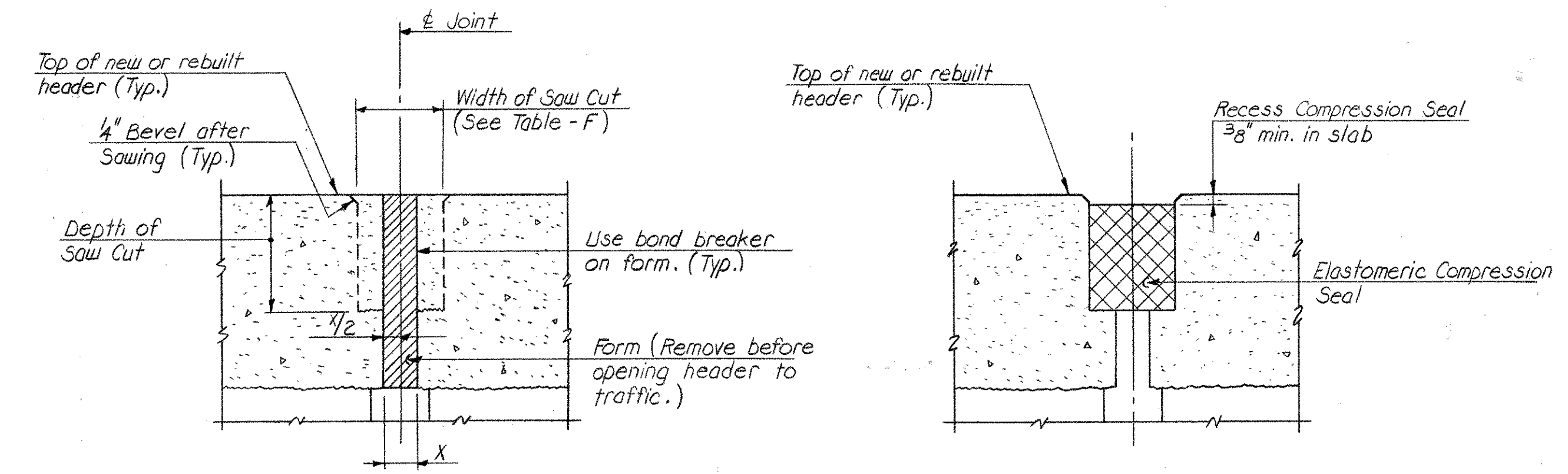

JOINT DETAIL FOR ELASTOMERIC COMPRESSION SEAL

Elastomeric Compression Seal		Joint Dimensions					Dim. X	
Nominal Width	Type	Width of Saw Cut		Depth of Saw Cut				
		Ambient Temperature Range at time of Sawing Joint		Elastomeric Compression Seal Type				
		30°-50°	50°-70°	70°-90°	"A"	"B"	"C"	
2	A, B or C	1 ³ / ₈ "	1 ¹ / ₈ "	1 ¹ / ₄ "	2 ⁵ / ₈ "	2 ³ / ₈ "	2 ³ / ₄ "	1 ¹ / ₂ "
3	A, B or C	2 ¹ / ₈ "	1 ¹ / ₈ "	1 ¹ / ₈ "	4"	4"	4"	1"
4	A, B or C	2 ³ / ₄ "	2 ¹ / ₈ "	2 ³ / ₈ "	5 ¹ / ₂ "	5"	5 ¹ / ₄ "	1 ¹ / ₂ "

NOTE WELL: It is important that the joint be constructed exactly as detailed. See TABLE-F for joint dimensions. Cost of sawcut shall be included in the contract unit bid price per linear foot for "Saw Cutting Bridge Joints". The compression seal shall not be installed above temperatures at which the width of joint is less than 60% of the nominal width of the seal.

ELASTOMERIC COMPRESSION SEAL DETAILS

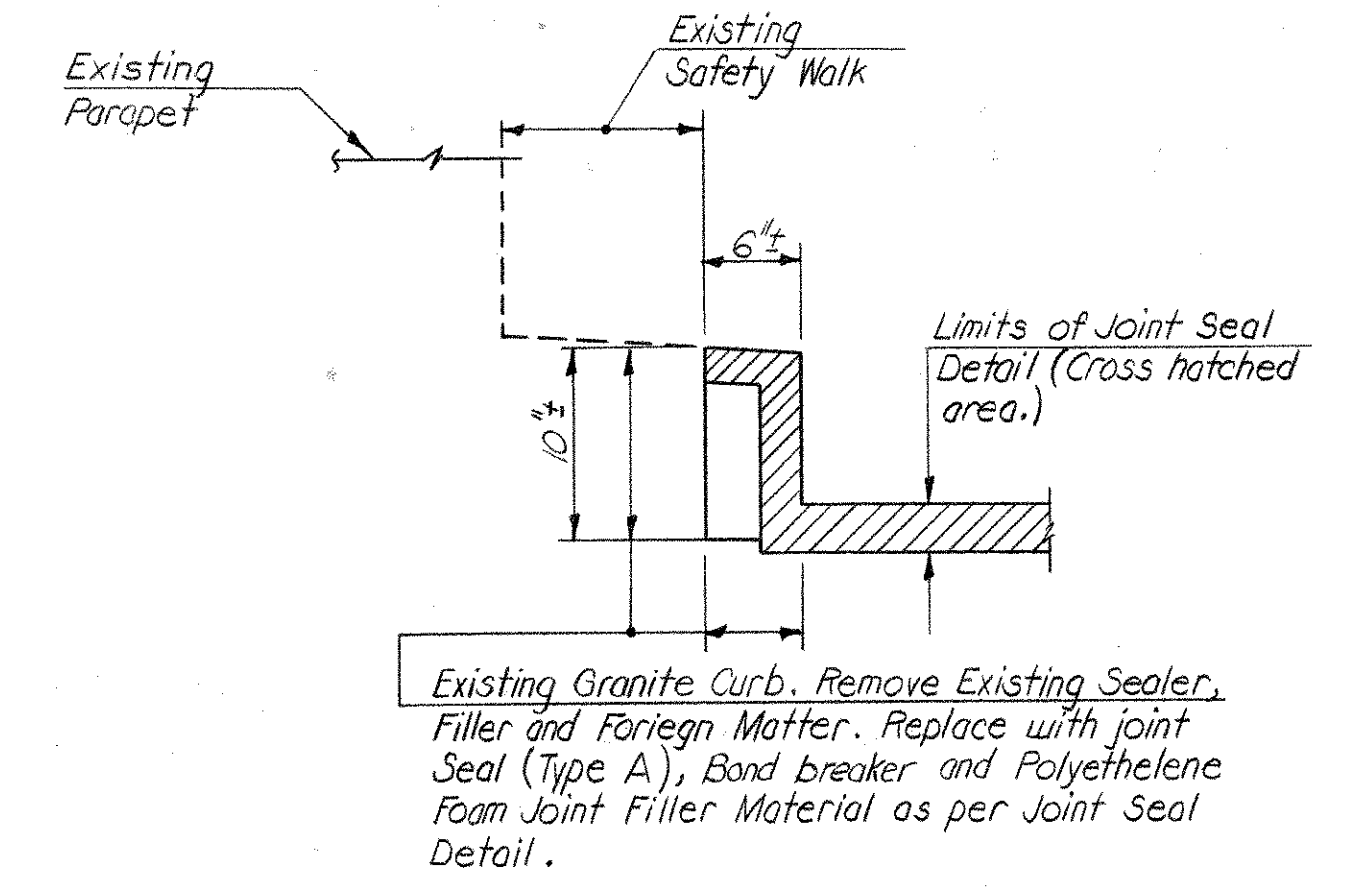

LIMITS OF JOINT SEAL
Not to Scale

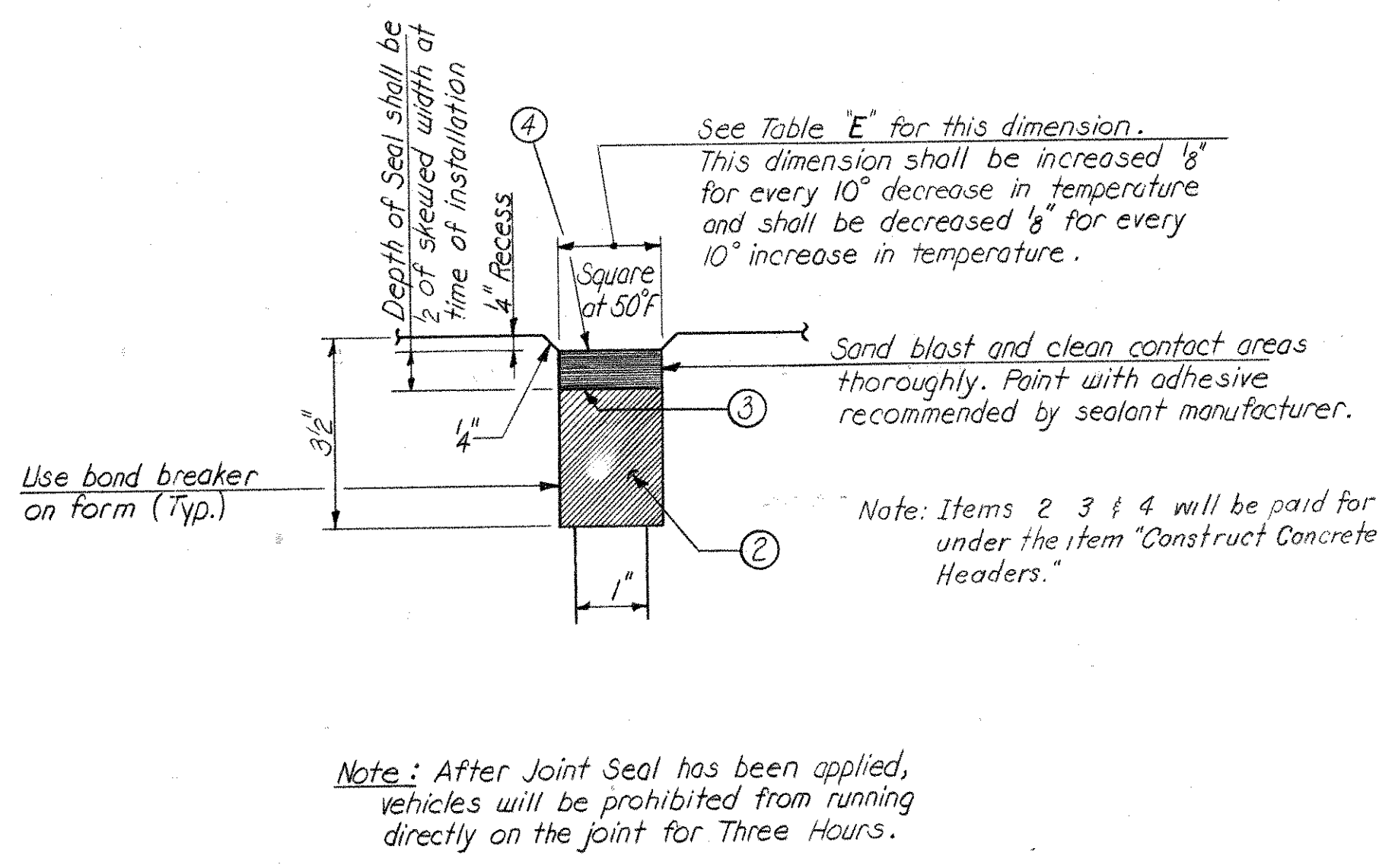

JOINT DETAIL FOR JOINT SEAL (TYPE "A")
Not to Scale

NOTES

- Remove defective sealer, filler & foreign matter (Full Depth). Replace with items ④② to 3" depth. Cost of this work shall be paid for at the contract unit price per foot for "Clean and Reseal Existing Filled Bridge Joints".
- Polyethylene Foam Joint Filler Material. It shall be a min. of 1" wider than joint at installation.
- Use Aluminum Foil, Masking Tape or Polyethylene Tape for a bond breaker.
- Joint Seal (depth = 1/2 width) width depends on field conditions. Joint seal shall be Joint seal (Type A).
- Center 12" strip of membrane waterproofing and place transversely along joint. Longitudinal membrane waterproofing to be continuous over joint.
- Membrane Waterproofing. See Plan sheets for type.
- Bituminous Concrete Wearing Surface. See General Notes.
- Cut wearing surface with a 3/8" x 1/4" deep kerf and fill with a pourable sealant. Cost of cutting and sealing to be paid for at the contract unit price per foot for "Sawing & Sealing Joints".

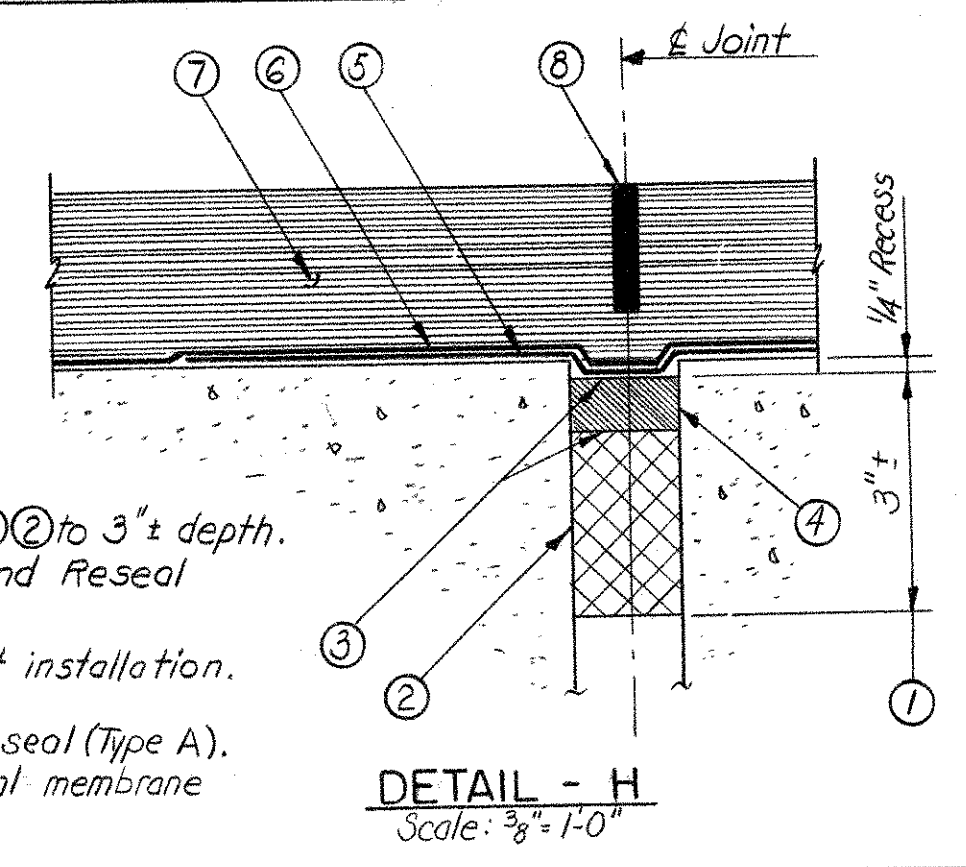

DETAIL - H
Scale: 3/8" = 1'-0"

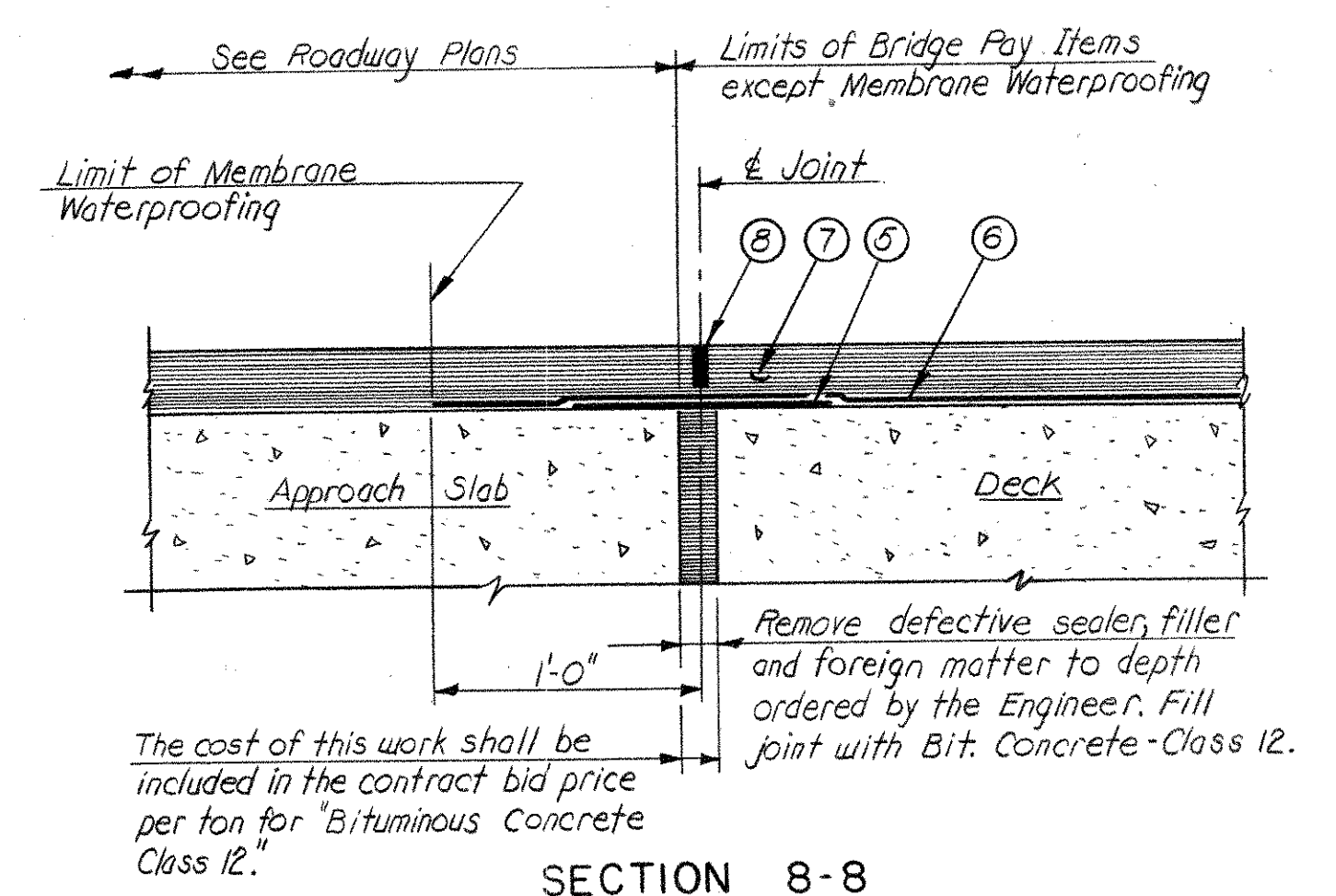

SECTION 8-8
Scale: 1/2" = 1'-0"

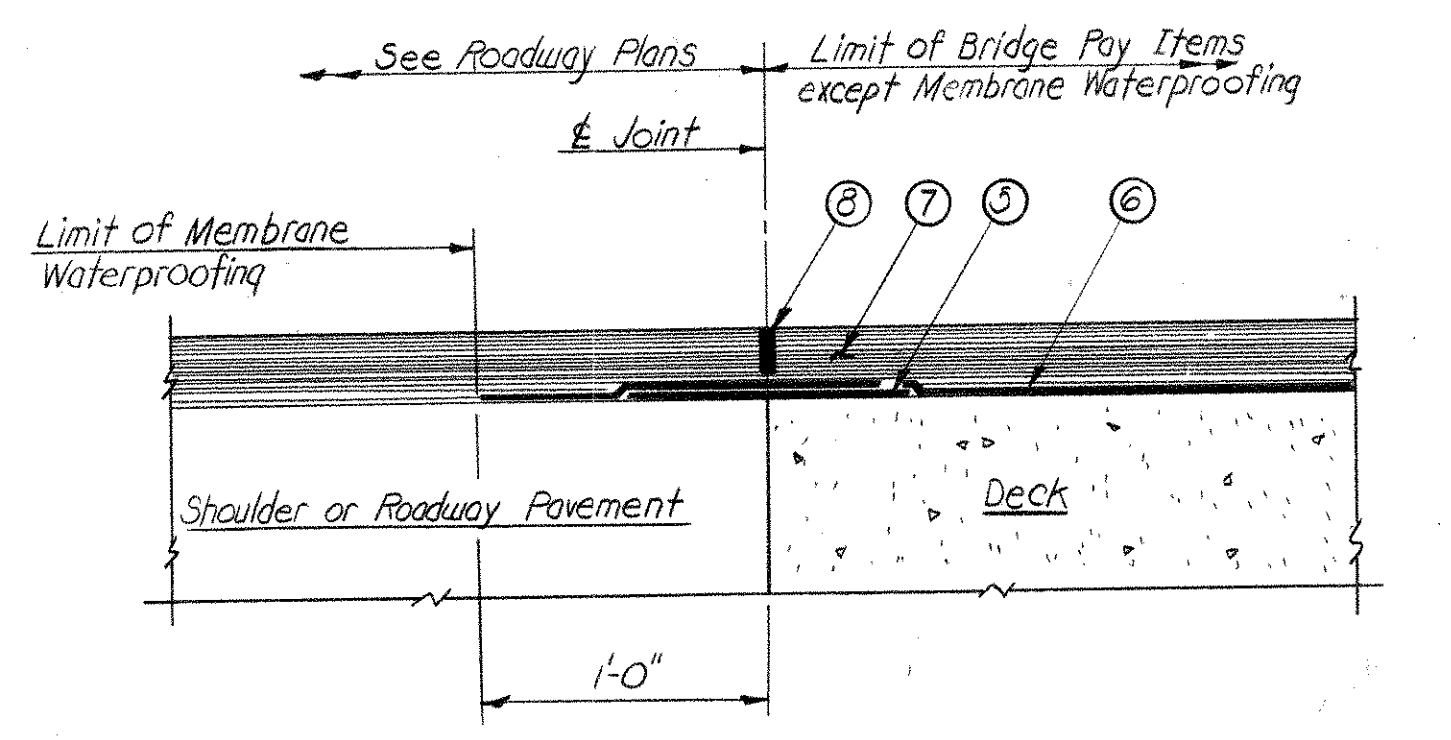

SECTION 9-9
Scale: 1/2" = 1'-0"

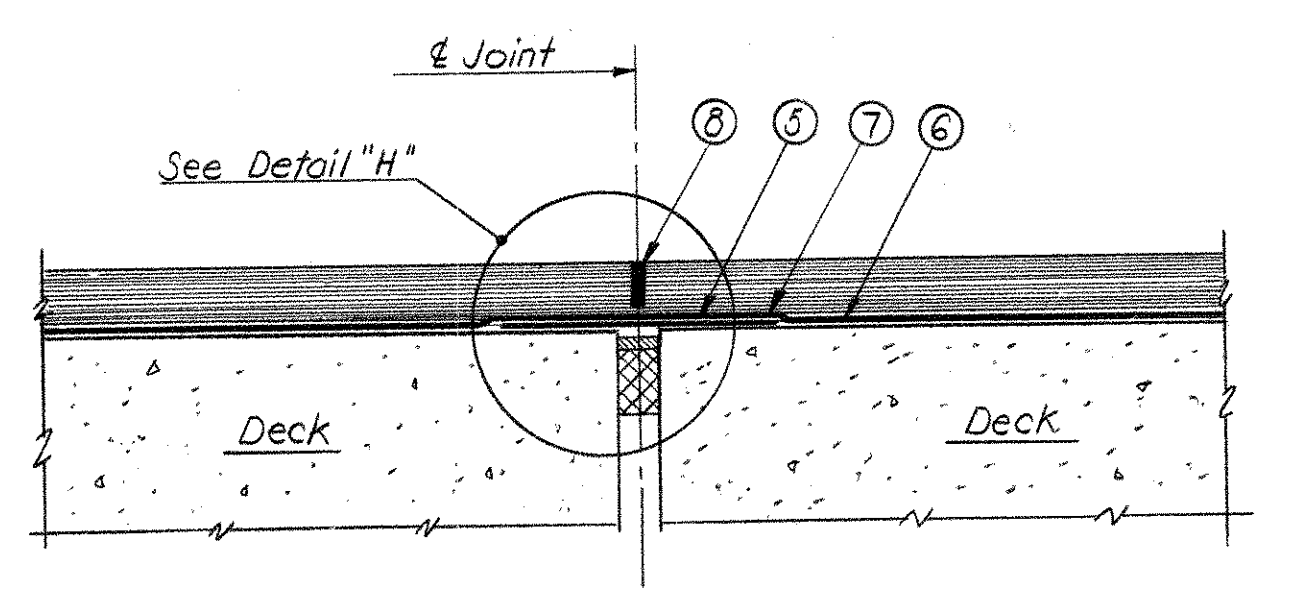

SECTION 10-10
Scale: 1/2" = 1'-0"

THE INFORMATION, INCLUDING ESTIMATED QUANTITIES OF WORK SHOWN ON THESE SHEETS IS BASED ON LIMITED INVESTIGATIONS BY THE STATE AND IS IN NO WAY WARRANTED TO INDICATE THE TRUE CONDITIONS OR ACTUAL QUANTITIES OR DISTRIBUTION OF QUANTITIES OF WORK WHICH WILL BE REQUIRED.

STATE OF CONNECTICUT
DEPARTMENT OF TRANSPORTATION
 SOUTHINGTON-HARTFORD
 INTERSTATE RTE. 84
 59 STRUCTURES
 DECK REPAIRS
 JOINT DETAILS - 2

ENGINEER BRIDGE DESIGN UNIT
 DESIGNER G. J. A. DRAFTER J. J. C. CHECKER G. D. B.
 APPROVED [Signature] DATE 3/17/82
 STRUCTURE NO. BRIDGE LOG NO. STRUCTURE SHEET NO. 86 of 87

F.H.W. REGION	STATE	TOWN	FED. AID PROJ. NO.	PROJ. NO.	YEAR	ROUTE NO.	SHEET NO.	TOTAL SHEETS
1	CONN.	Southington-Hartford	HR-24(53)12	131-145	1982	I-84	100	115

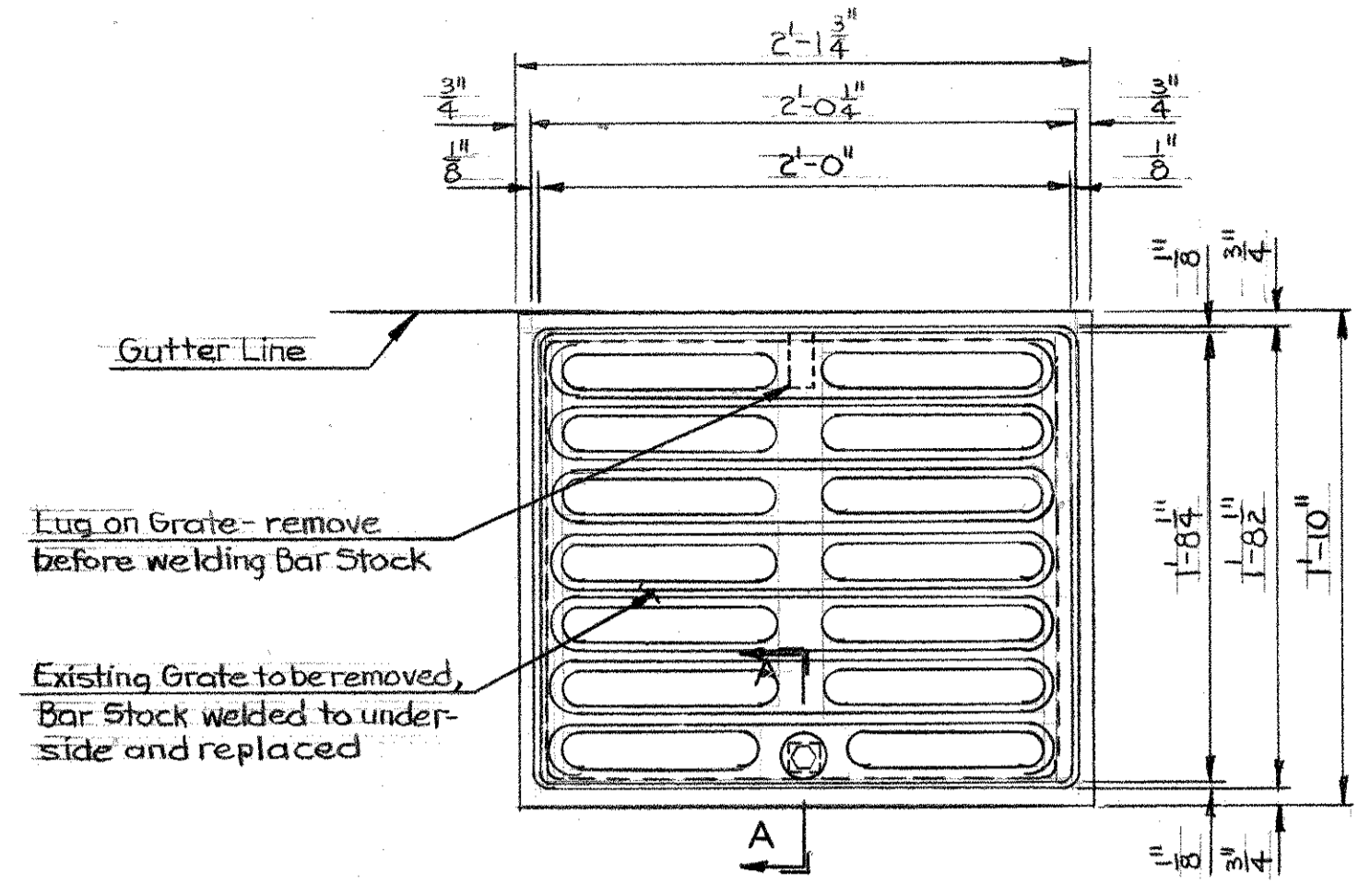

PLAN - TYPE I
Existing Condition
Scale 1 1/2"=1'-0"

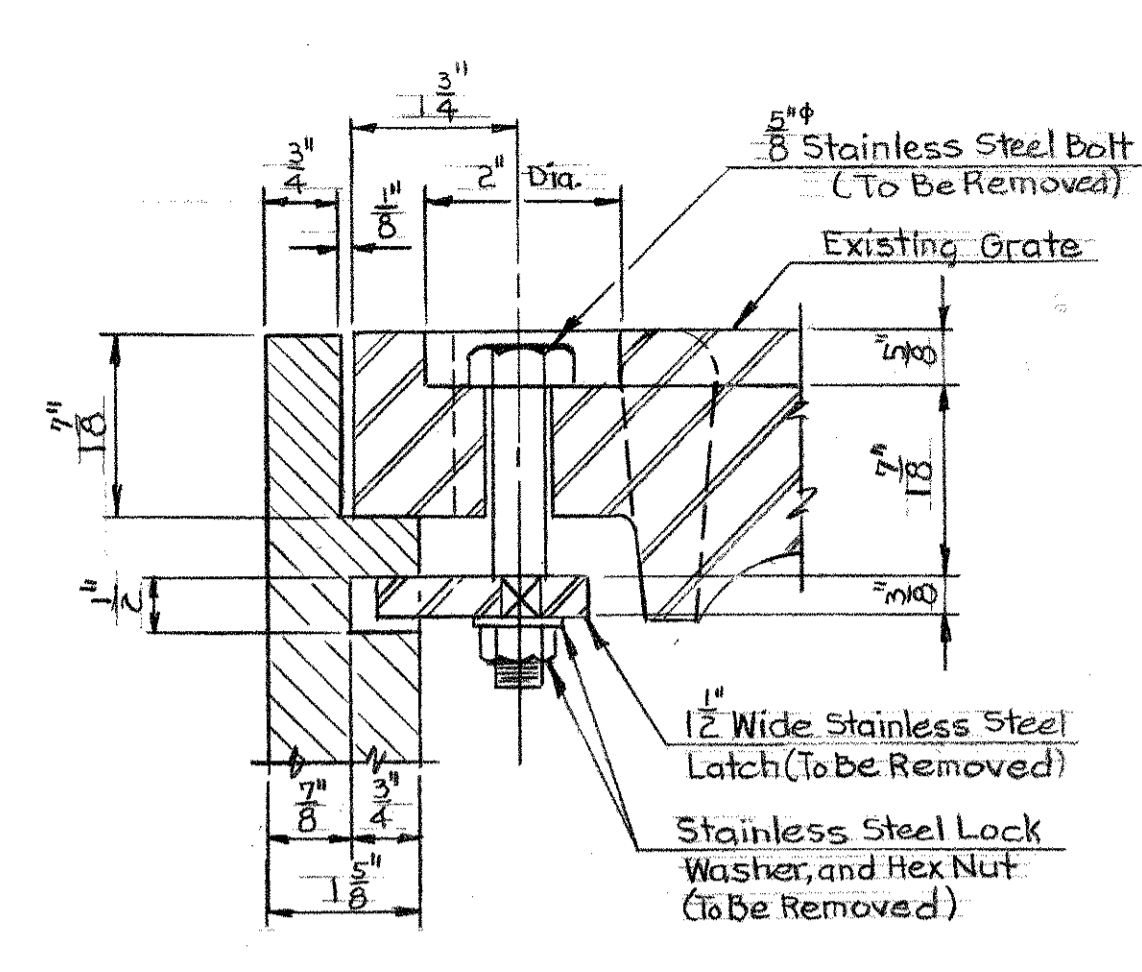

SECTION A-A
Half Scale

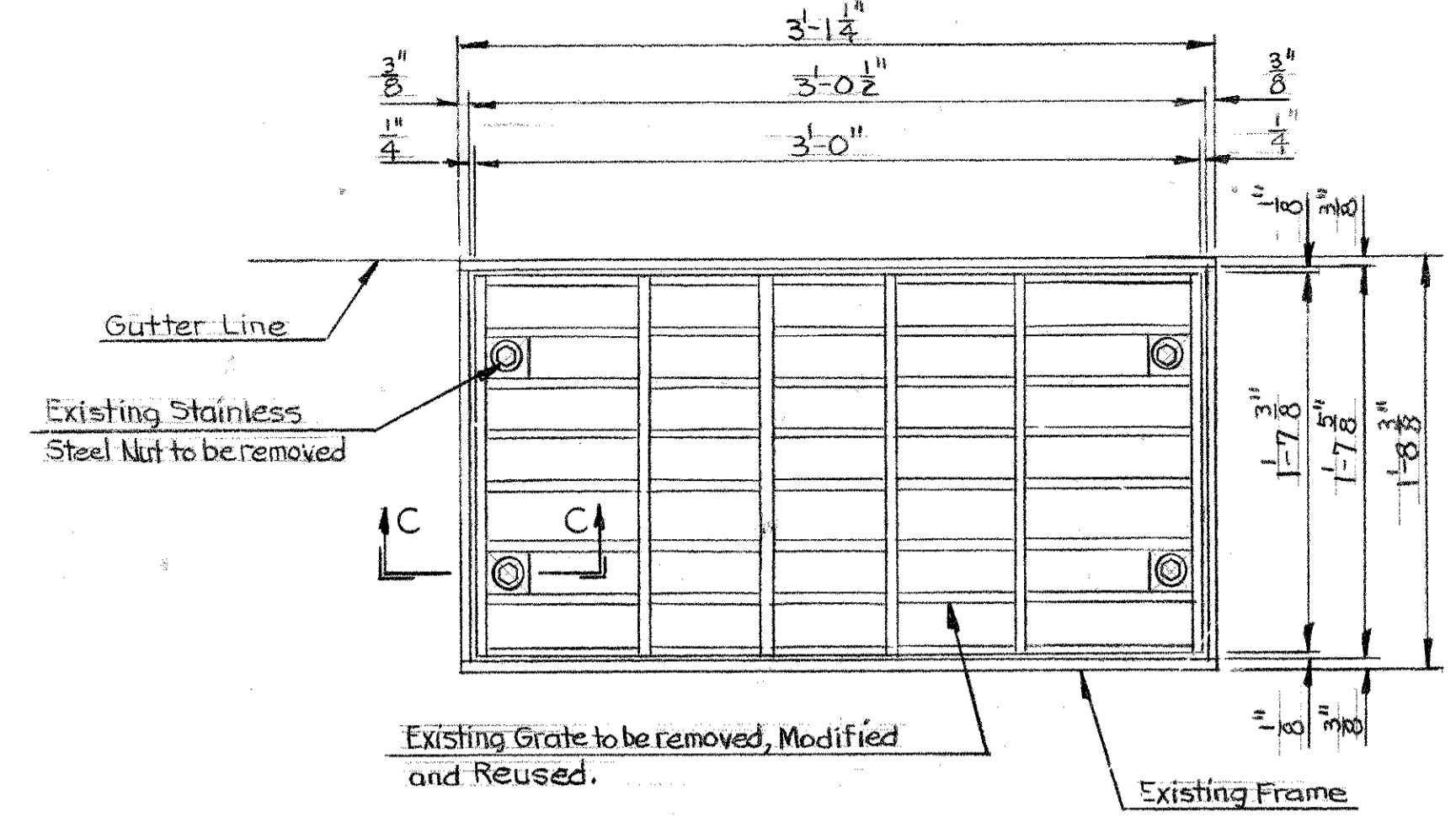

PLAN - TYPE II
Existing Condition
Scale 1 1/2"=1'-0"

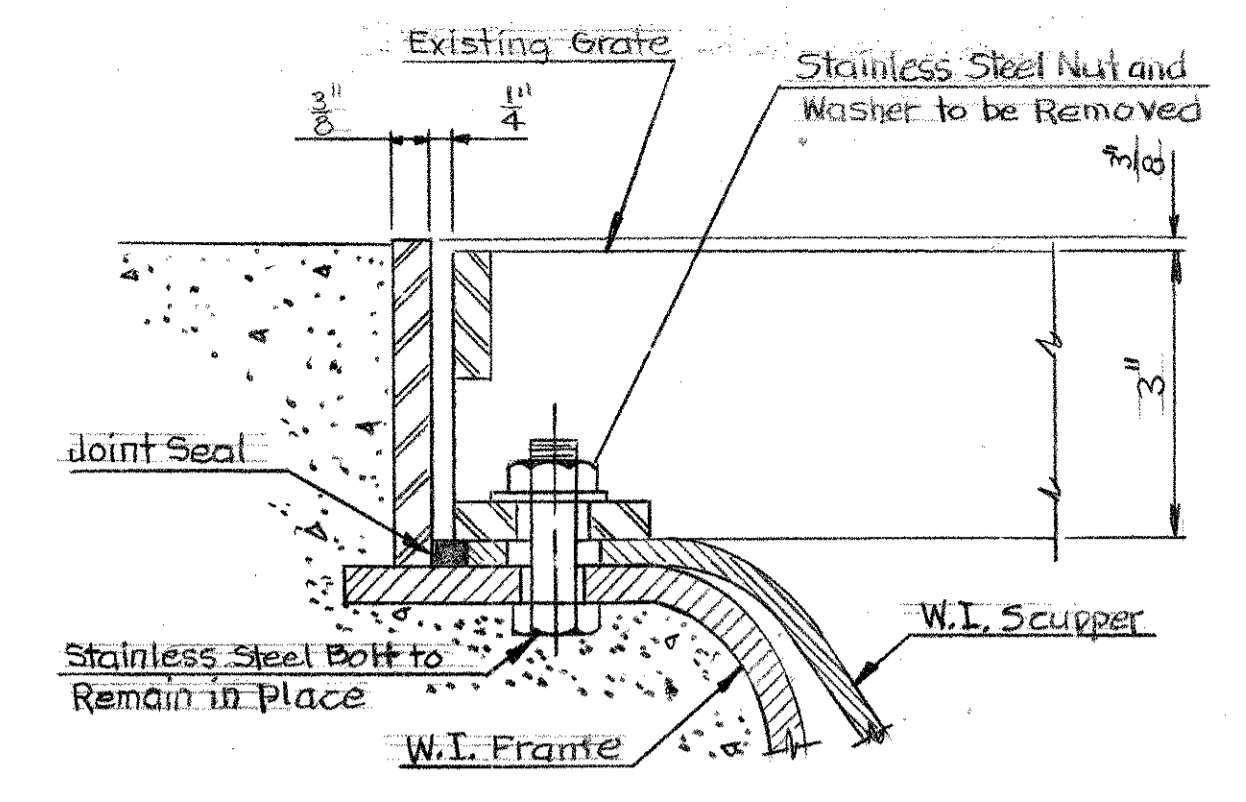

SECTION C-C
Half Scale

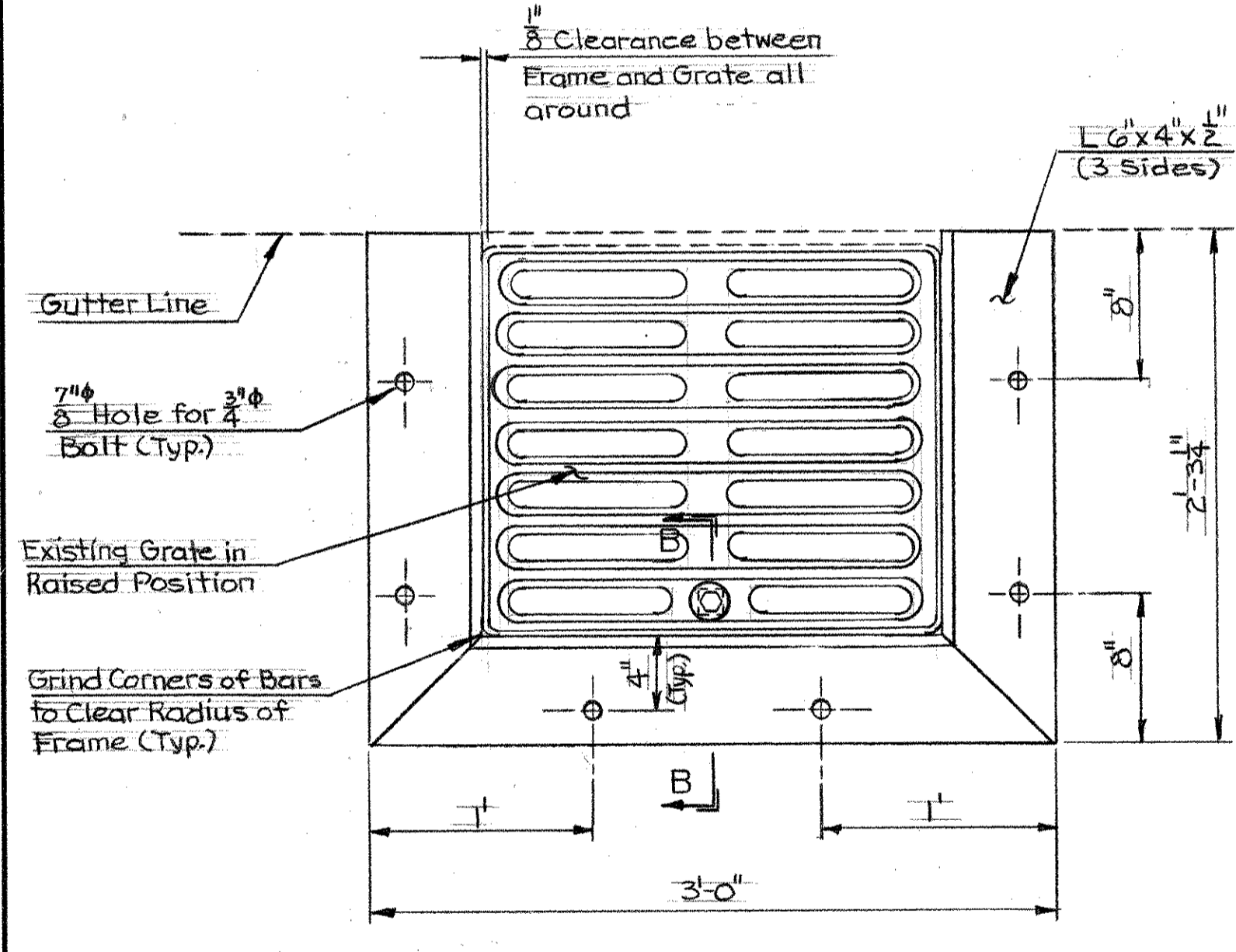

PLAN - TYPE I
Final Condition
Scale 1 1/2"=1'-0"

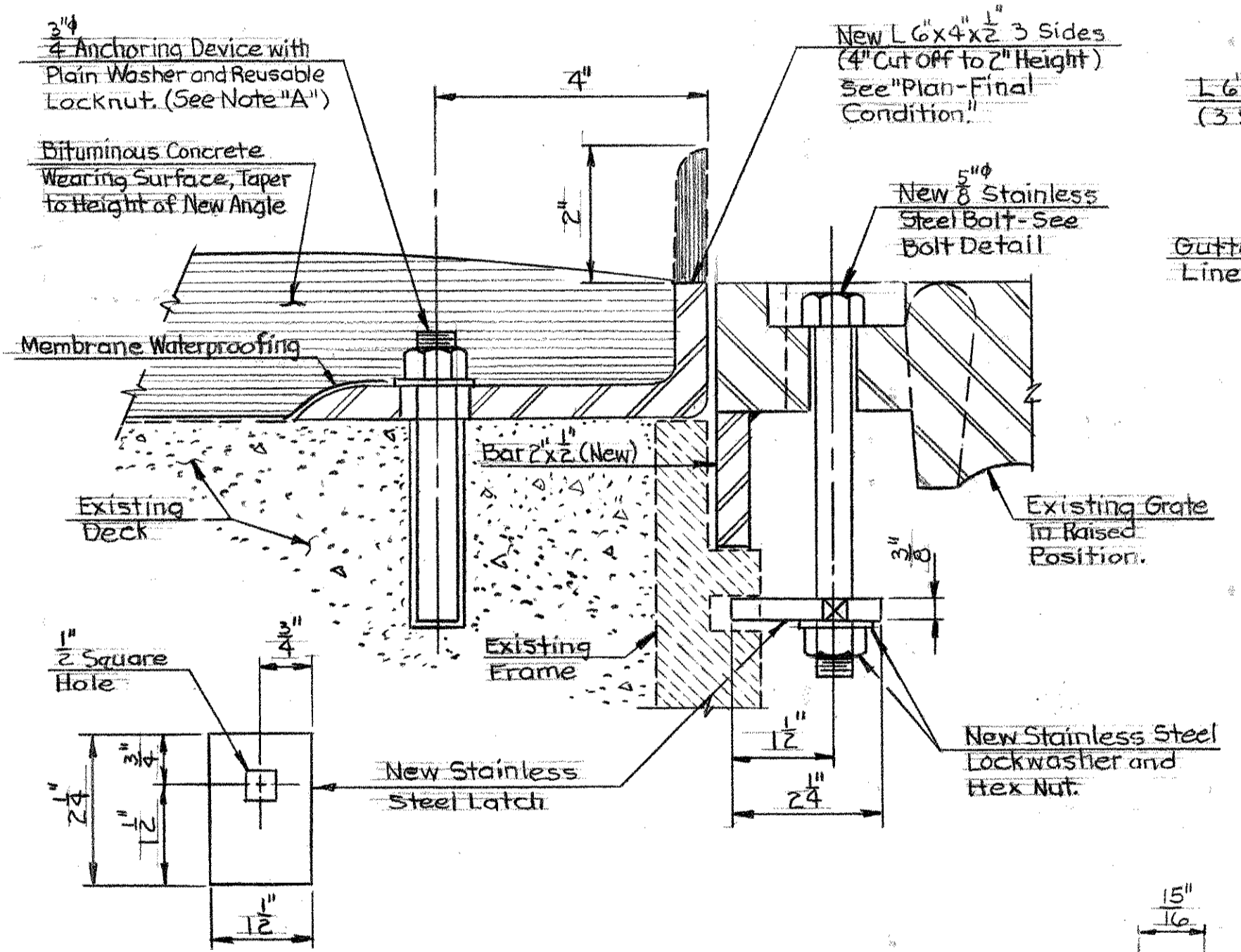

SECTION B-B
Half Scale

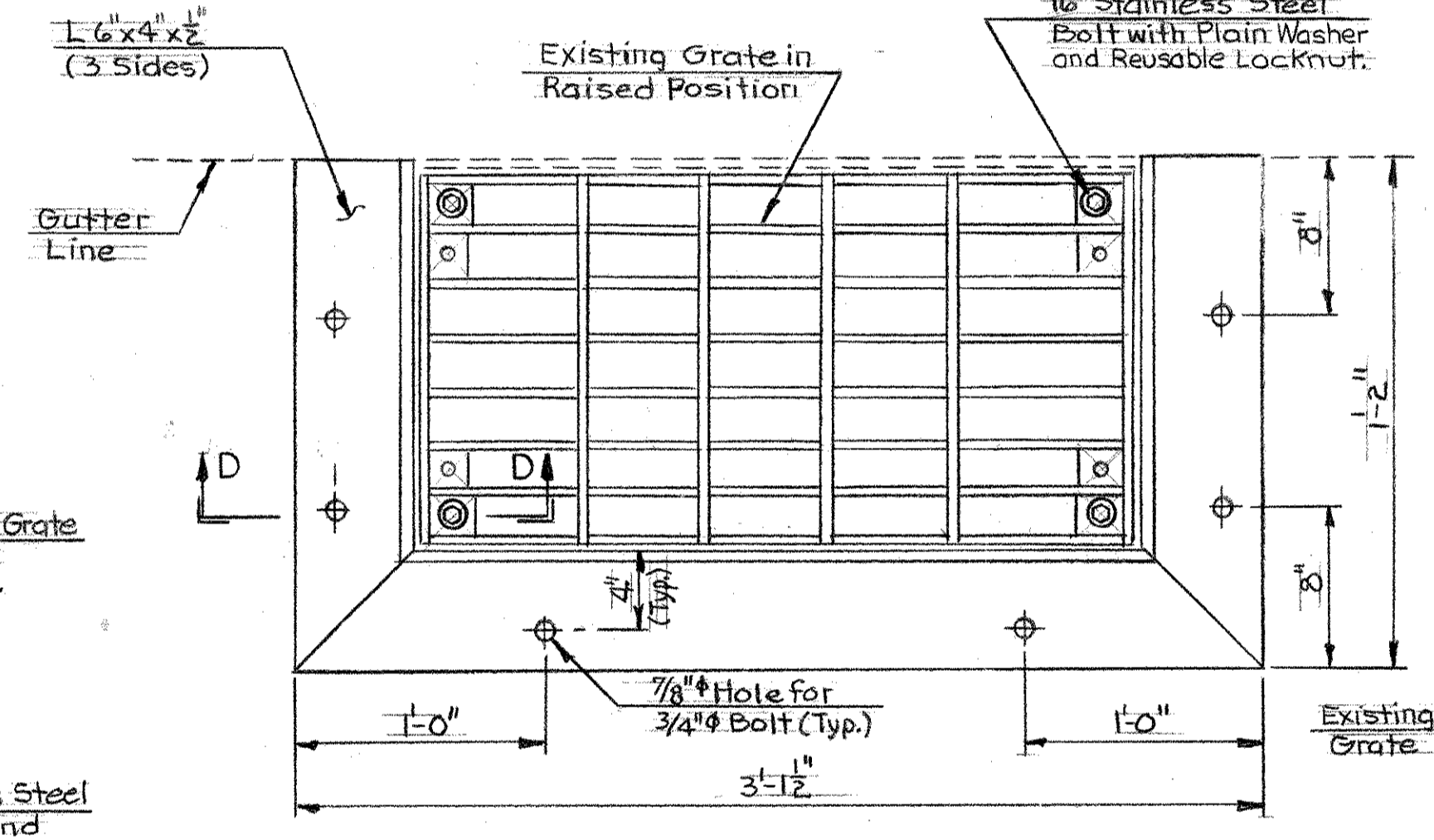

PLAN TYPE II
Final Condition
Scale 1 1/2"=1'-0"

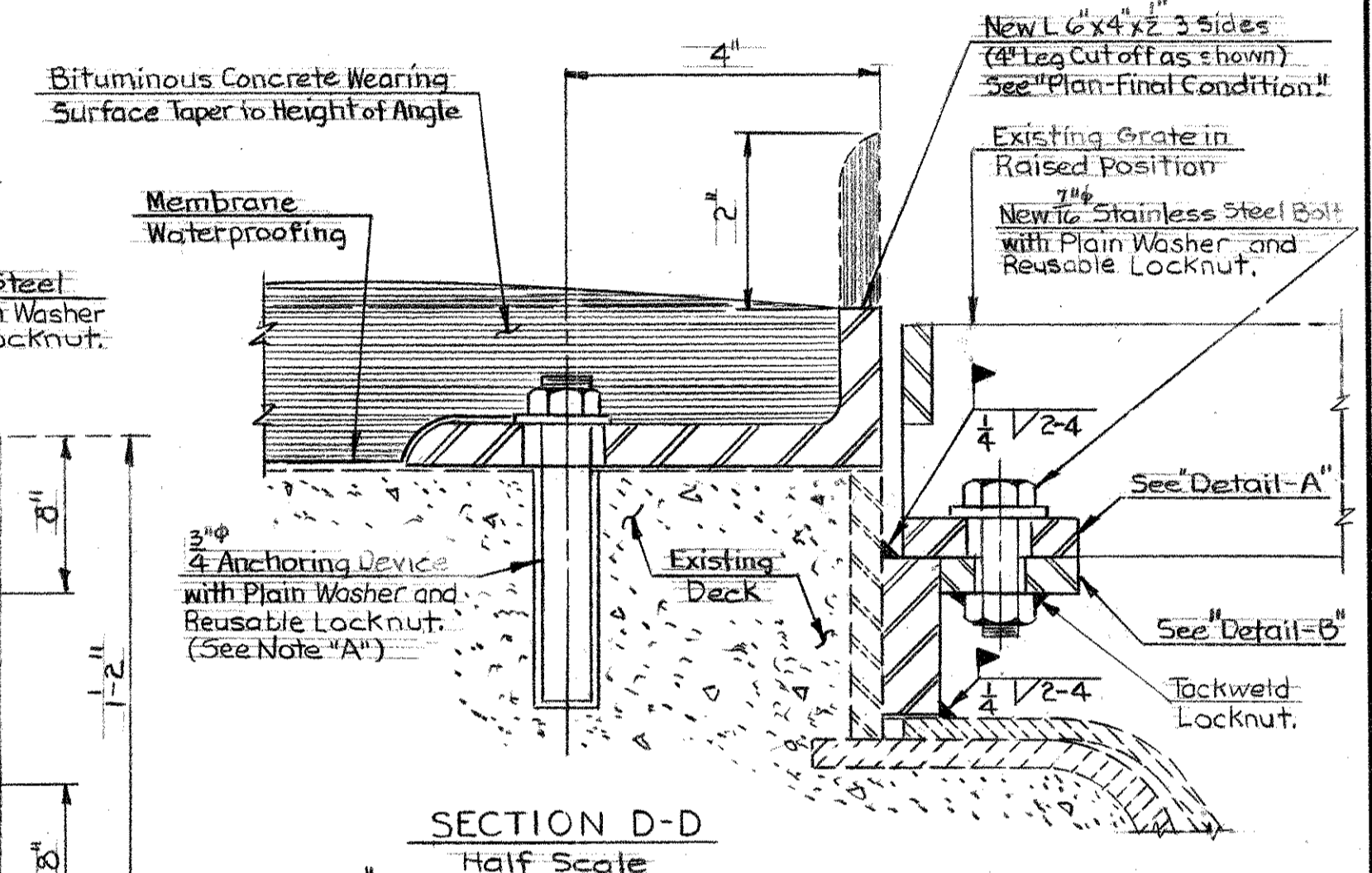

SECTION D-D
Half Scale

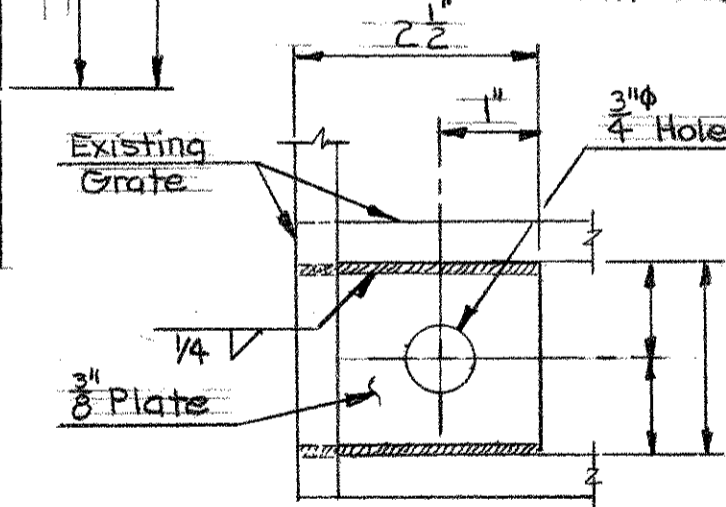

DETAIL-A
Half Scale

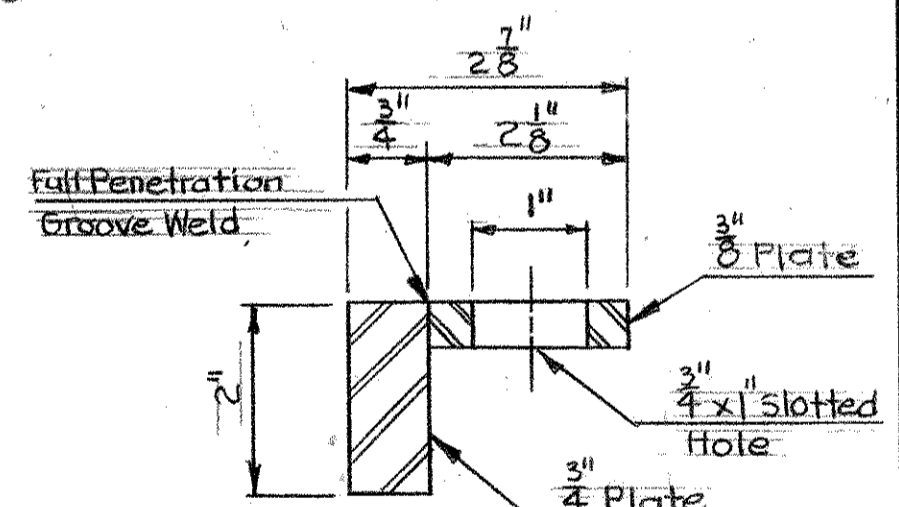

DETAIL-B
Half Scale

TYPE II SCUPPER MODIFICATION DETAILS

TYPE I SCUPPER MODIFICATION DETAILS

NOTE "A"
Anchoring Devices shall conform to Federal Spec. F.F.S.-325 Group II, Type 4, Class For 2- 7/8" Dia. Minimum Embedment 4". Torque Nuts to 65 FT. LBS. (Typ)

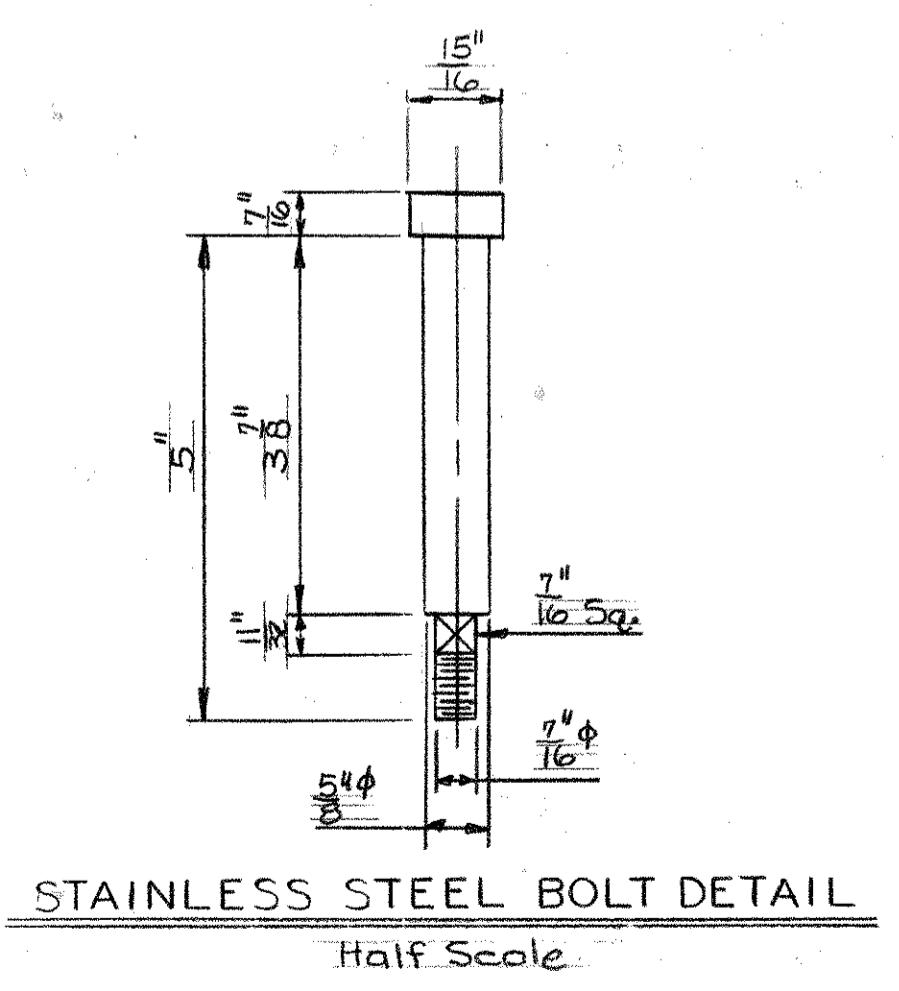

STAINLESS STEEL BOLT DETAIL
Half Scale

NOTES
The Existing Grate shall be removed, cleaned of all rust, dirt, oil, dust and foreign matter before field welding bar stock. The cost of this work and furnishing and installing new angles, bar stock, 3/4" expansion anchor devices and new bolts shall be included in the item "Modify Scupper Frame and Grate."
All new steel shall conform to A.S.T.M. A-588.
All dimensions of existing scuppers shall be verified in the field before fabrication to insure proper fit.

THE INFORMATION, INCLUDING ESTIMATED QUANTITIES OF WORK SHOWN ON THESE SHEETS IS BASED ON LIMITED INVESTIGATIONS BY THE STATE AND IS IN NO WAY WARRANTED TO INDICATE THE TRUE CONDITIONS OR ACTUAL QUANTITIES OR DISTRIBUTION OF QUANTITIES OF WORK WHICH WILL BE REQUIRED.

NO.	DATE	DESCRIPTION

STATE OF CONNECTICUT			
DEPARTMENT OF TRANSPORTATION			
SOUTHINGTON-HARTFORD			
INTERSTATE RTE. 84			
59 STRUCTURES			
DECK REPAIRS			
SCUPPER MODIFICATION DETAILS			
ENGINEER Bridge Design Unit			
DESIGNER G. J. A.		DRAFTER F. T. R.	
APPROVED <i>[Signature]</i>		CHECKER G. D. B.	
DATE 3/17/82		DATE 3/17/82	
STRUCTURE NO.		BRIDGE LOG NO.	
		STRUCTURE SHEET NO.	
		87 of 87	

F. H. A. Region No.	State	Town	Fed. Aid Proj. No.	Proj. No.	Year	Route No.	Sheet No.	Total Sheets
CONN.		HARTFORD	1-18-84-3 (55)42	131-145	1982	I-84	11	115

I-84 BRIDGE DECK REPAIRS

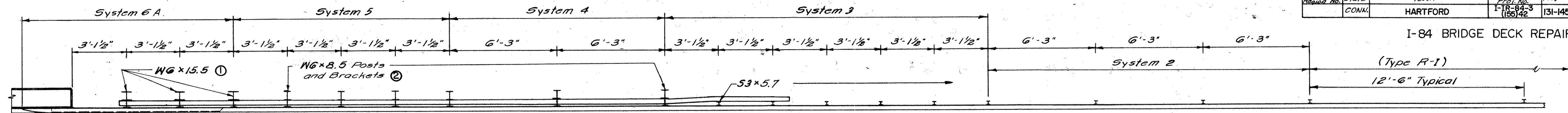

For additional details see MISCELLANEOUS DETAILS METAL BEAM RAIL (TYPE R-1) SHEET 12

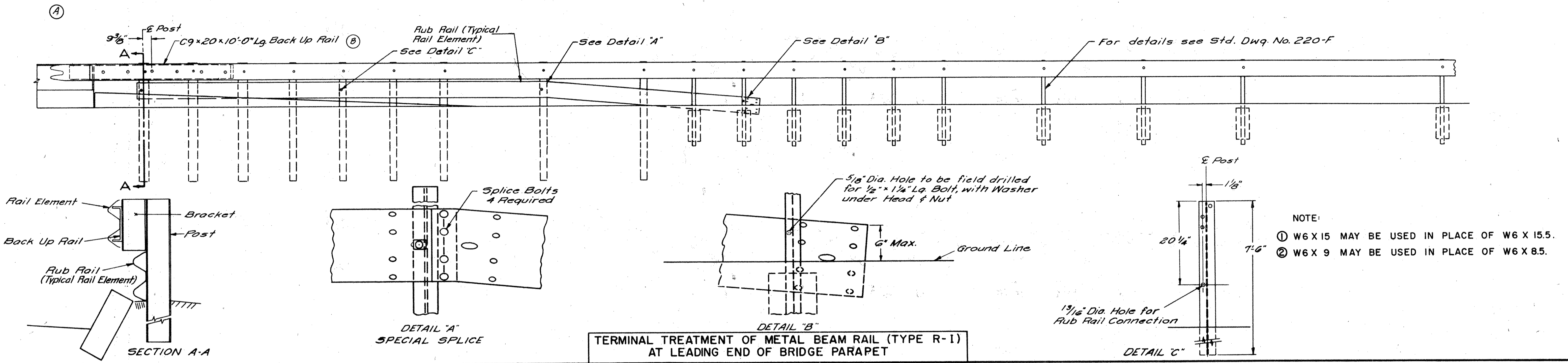

TERMINAL TREATMENT OF METAL BEAM RAIL (TYPE R-1) AT LEADING END OF BRIDGE PARAPET

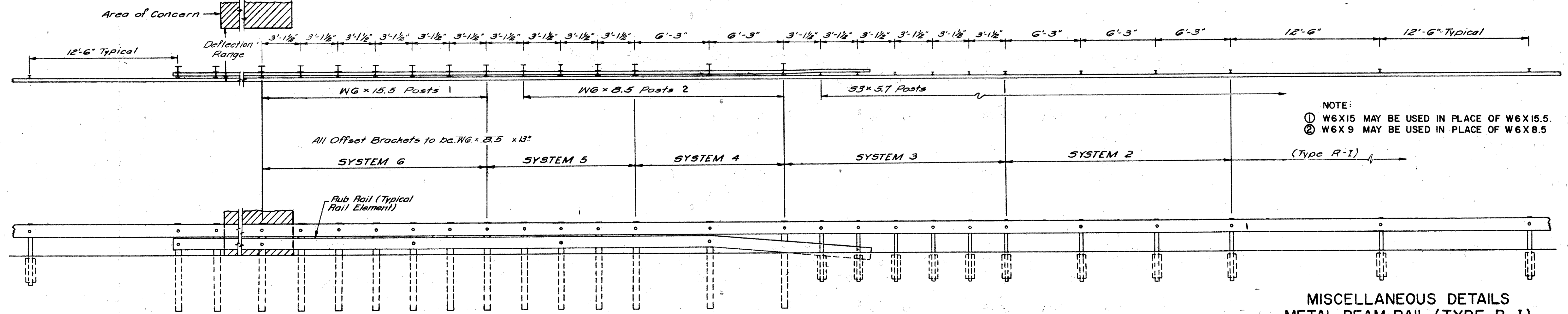

MISCELLANEOUS DETAILS METAL BEAM RAIL (TYPE R-1) SHEET A

	SYSTEM 6	SYSTEM 5	SYSTEM 4	SYSTEM 3	SYSTEM 2	(Type R-1)	TOTAL LENGTH
Maximum Anticipated Deflection	Area of Concern plus two posts, see sketch below	WG x 15.5 Posts at 3'-1 1/2" centers with Rub Rail ①	WG x 8.5 Posts at 3'-1 1/2" centers with Rub Rail ②	WG x 8.5 Posts at 6'-3" centers with Rub Rail ②	53 x 5.7 Posts at 3'-1 1/2" centers	53 x 5.7 Posts at 6'-3" Centers	Value of "L"
3'	Posts of Spacing for System 6	12'-6" min.	12'-6"	12'-6"	18'-9"	18'-9"	75'
3'	System 4		37'-6" min.	18'-9"	18'-9"		75'
4 1/2'	System 3			37'-6" min.	18'-9"		56'-3"
5'	System 2				37'-6" min.		37'-6"

TREATMENT OF METAL BEAM RAIL (TYPE R-1) AT FIXED OBJECT

CONNECTICUT DEPARTMENT OF TRANSPORTATION BUREAU OF HIGHWAYS SPECIAL STUDIES UNIT

NOT TO SCALE

REVISIONS			
NO.	DATE	DESCRIPTION	REV. SHEET NO.
A	7-78	Note Deletion	
B	7-78	Backup Rail Length Rev.	
C	12-74	Relocation change from 220'-6" to 220'-0"	
D	7-75	Nomenclature change	
E	2-77	Treatment of other changes	
F	4-80	Replacement of W6x15.5 with W6x15	

PUB. ROAD DIV. NO.	STATE	TOWN	FED. AID PROJ. NO.	PROJ. NO.	YEAR	ROUTE NO.	SHEET NO.	TOTAL SHEETS
1	CONN.	HARTFORD	I-IR-84-3(155)42	131-145	1982	I-84	12	115

I-84 BRIDGE DECK REPAIRS

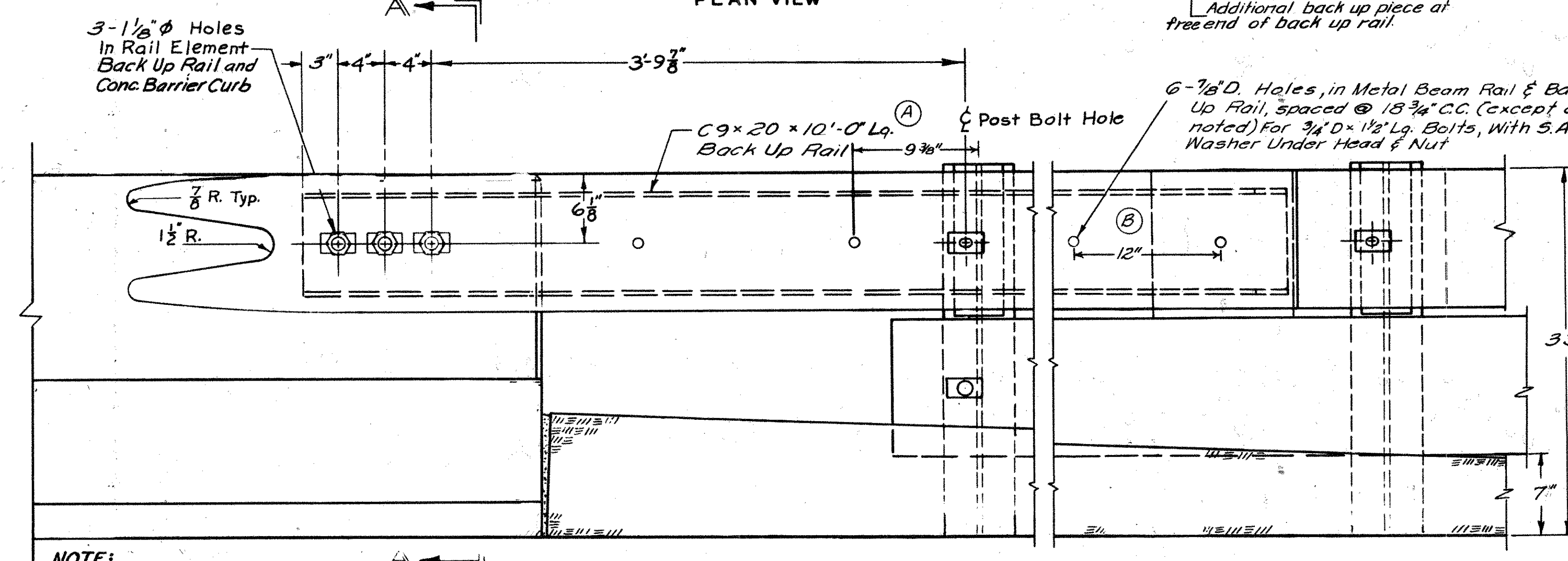
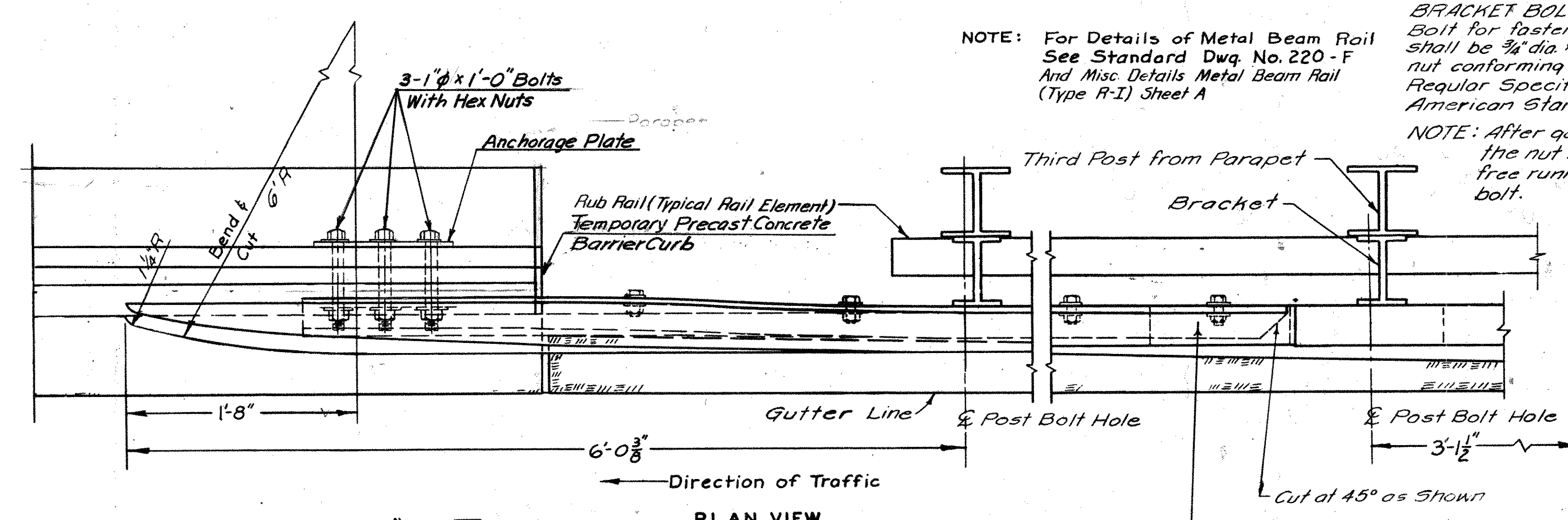

NOTE: Cost of Attachment and Appurtenances to be Included in the Unit Price for Metal Beam Type R-I System G-A

ATTACHMENT AT LEADING END OF TEMPORARY PRECAST CONCRETE BARRIER CURB

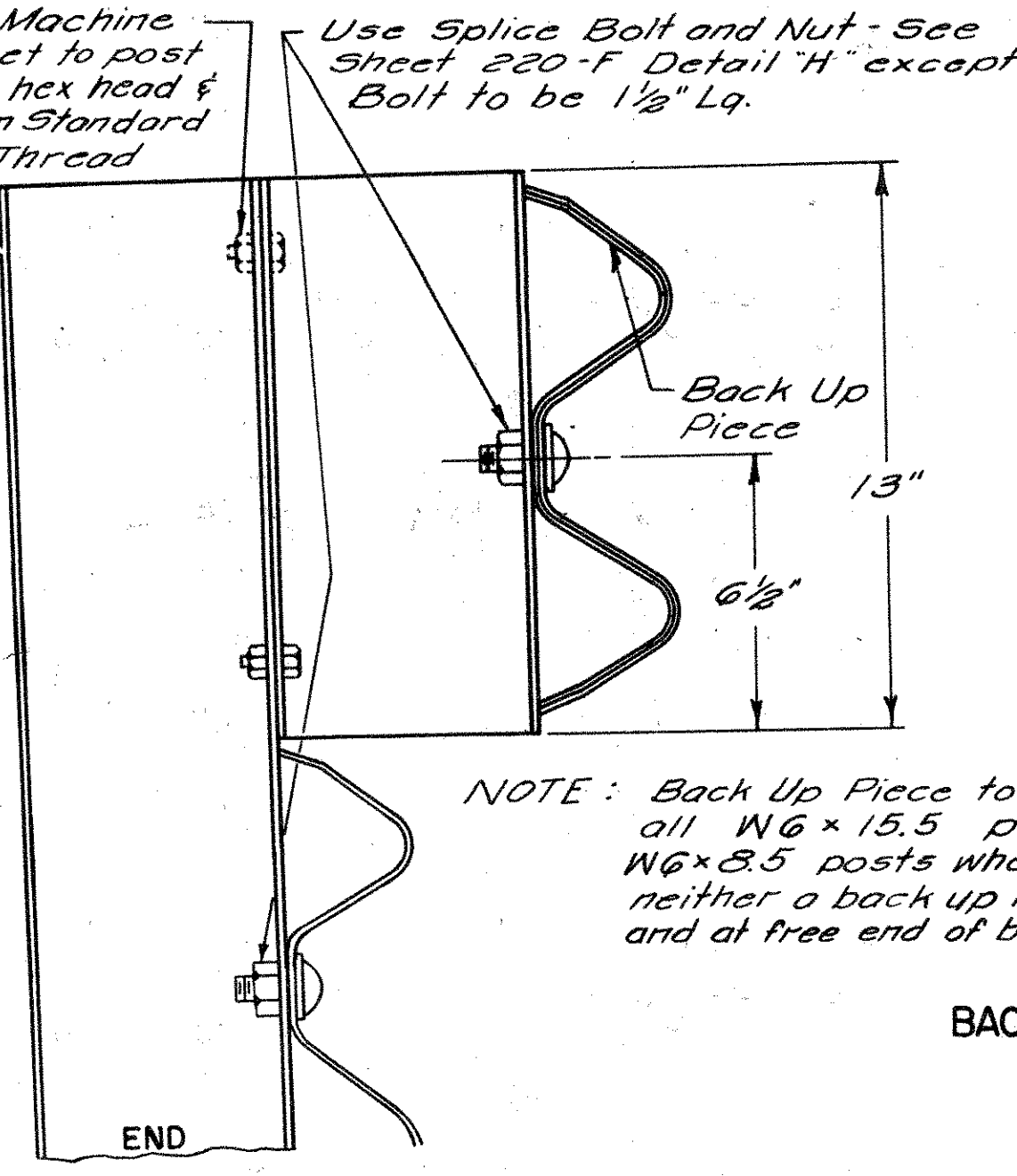

BACK UP PIECE

NOTE: Back Up Piece to be used on all W6 x 15.5 posts and W6 x 8.5 posts where there is neither a back up rail nor a splice, and at free end of back up rail.

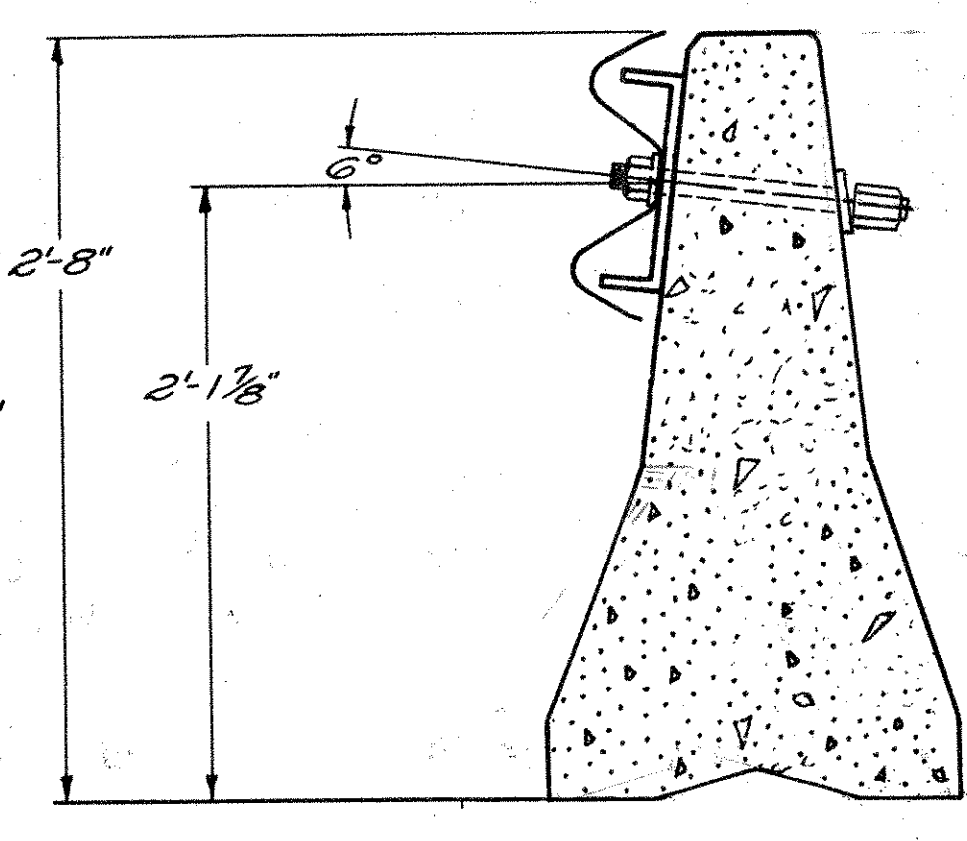
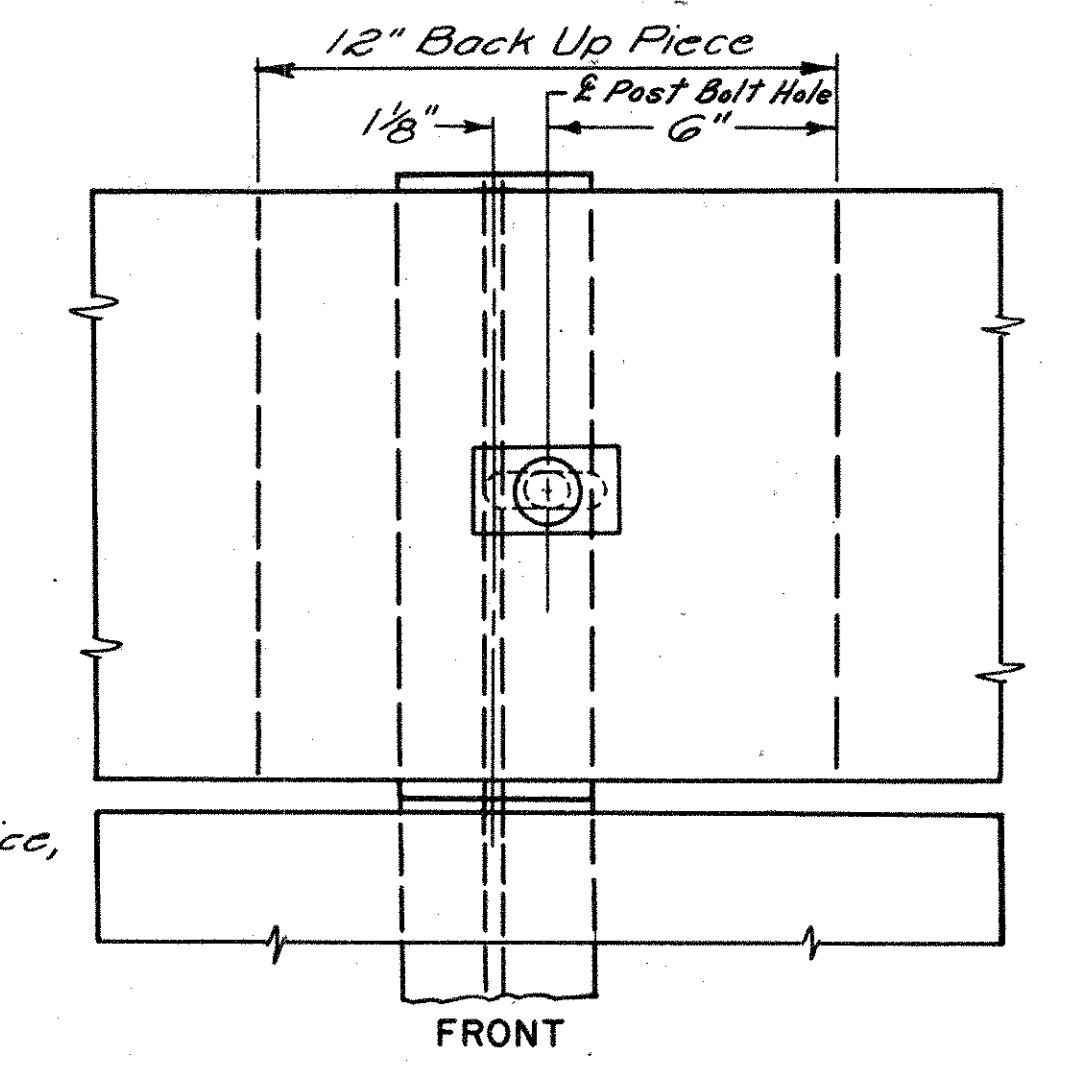

SECTION A-A

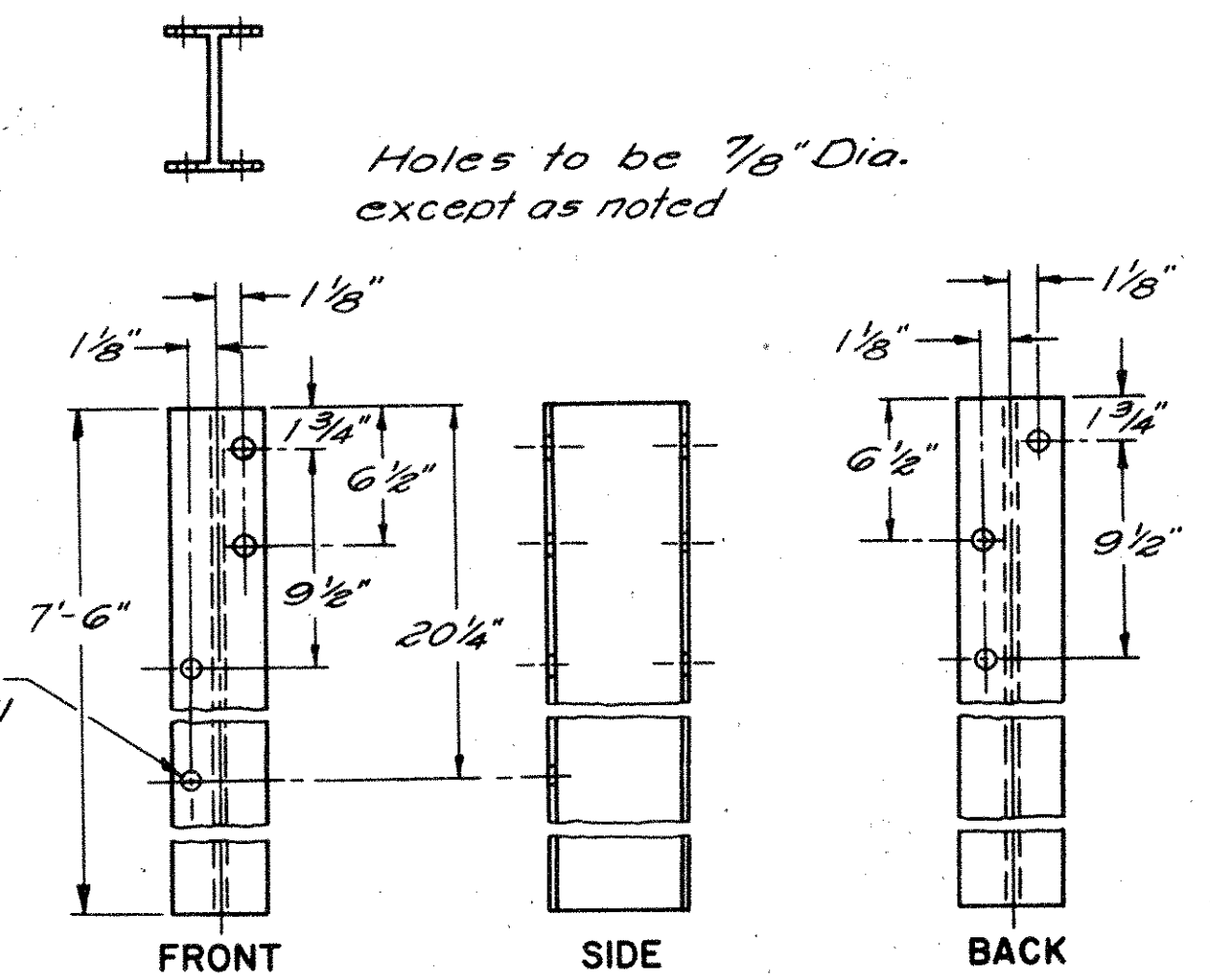

DETAIL SHOWING LOCATION OF HOLES FOR ATTACHING BRACKET TO POST

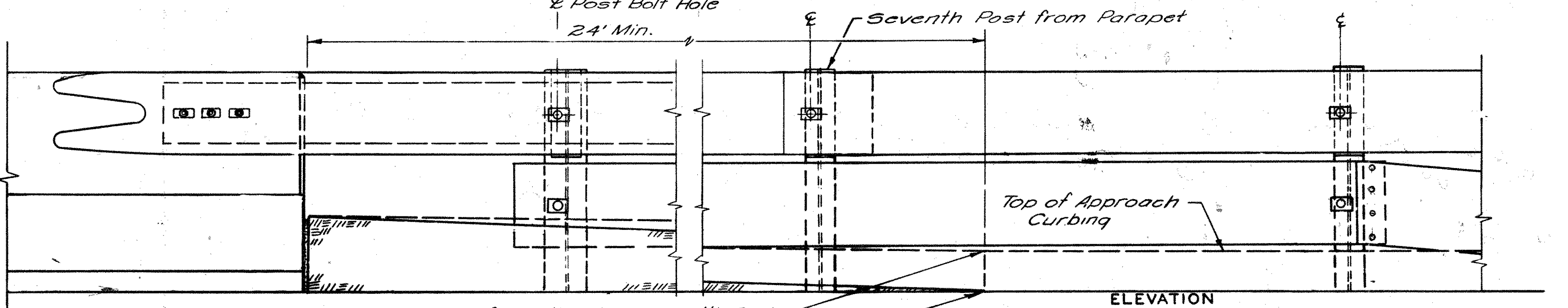
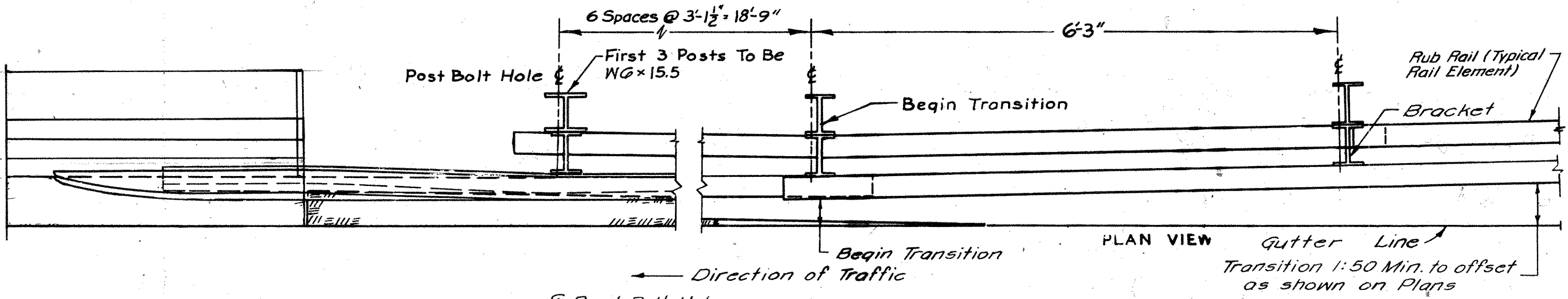

TRANSITION AT LEADING END OF TEMPORARY PRECAST CONCRETE BARRIER CURB

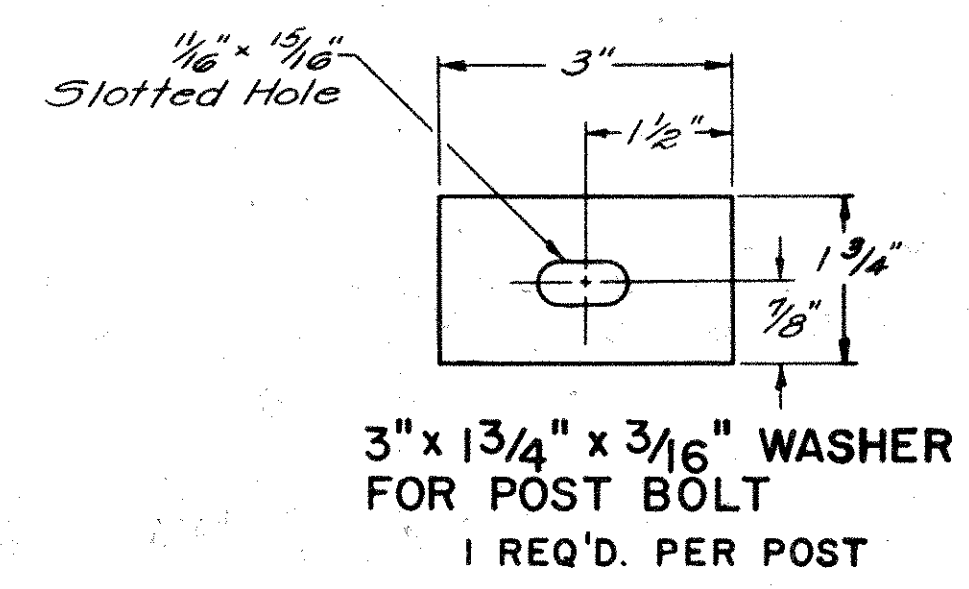

3" x 1 3/4" x 3/16" WASHER FOR POST BOLT
1 REQ'D. PER POST

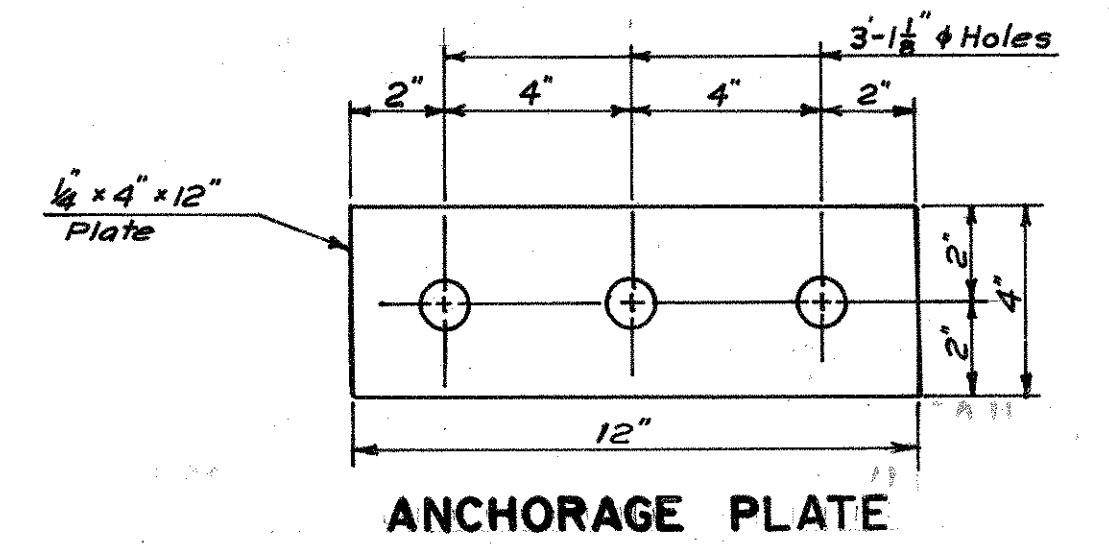

ANCHORAGE PLATE

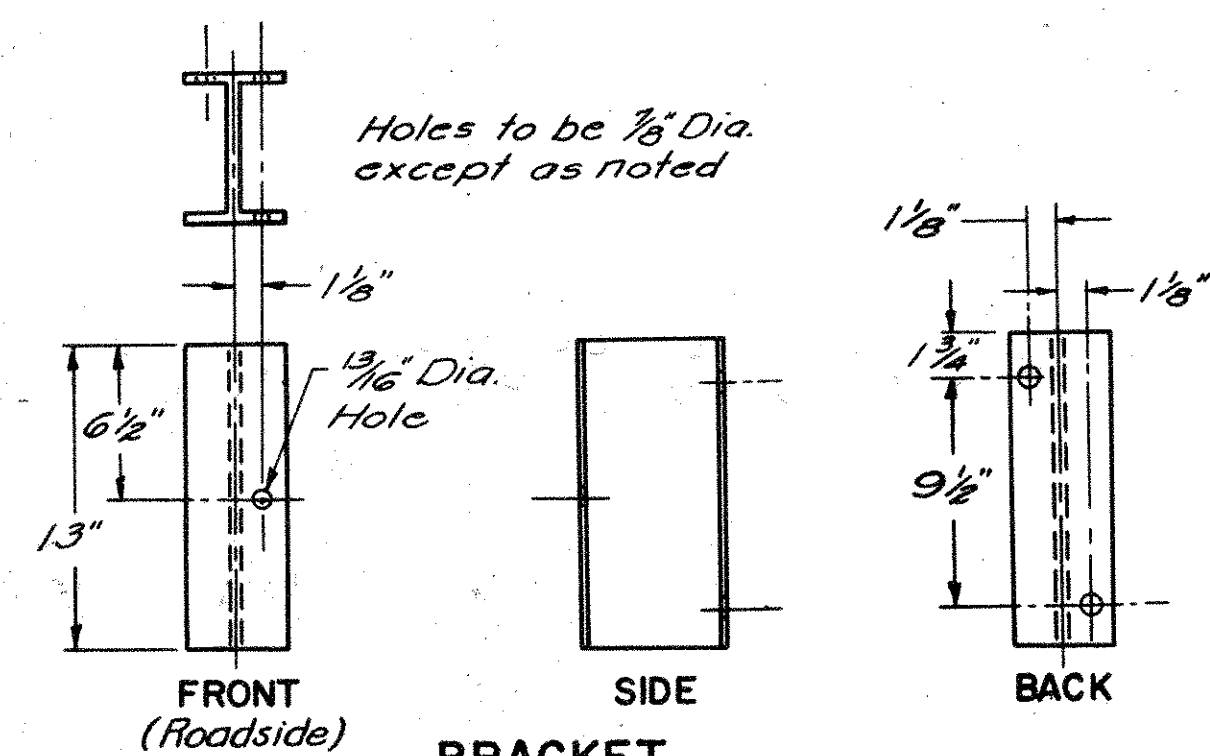

BRACKET
W6 x 8.5 x 1'-1"

THIS SHEET NOT CORRECTED

NOT TO SCALE

REVISIONS			
NO.	DATE	DESCRIPTION	REV. SHEET NO.
A	7-72	Back Up Rail Length Revised	
B	7-72	Hole Spacing	
C	7-72	Note Revised	
D	6-75	Sheet reference change	
E	7-75	Manufacture change	

NOTE BOOK NO.
 Planned
 Traced
 Designed
 New Check
 Rep. Field Chk. Interd.

PUR. ROAD DIV. NO.	STATE	TOWN	FED. AID PROJ. NO.	PROJ. NO.	YEAR	ROUTE NO.	SHEET NO.	TOTAL SHEETS
	CONN.	HARTFORD	I-TR-84-3 (165)42	131-145	1982	I-84	13	115

I-84 BRIDGE DECK REPAIRS

NOT TO SCALE

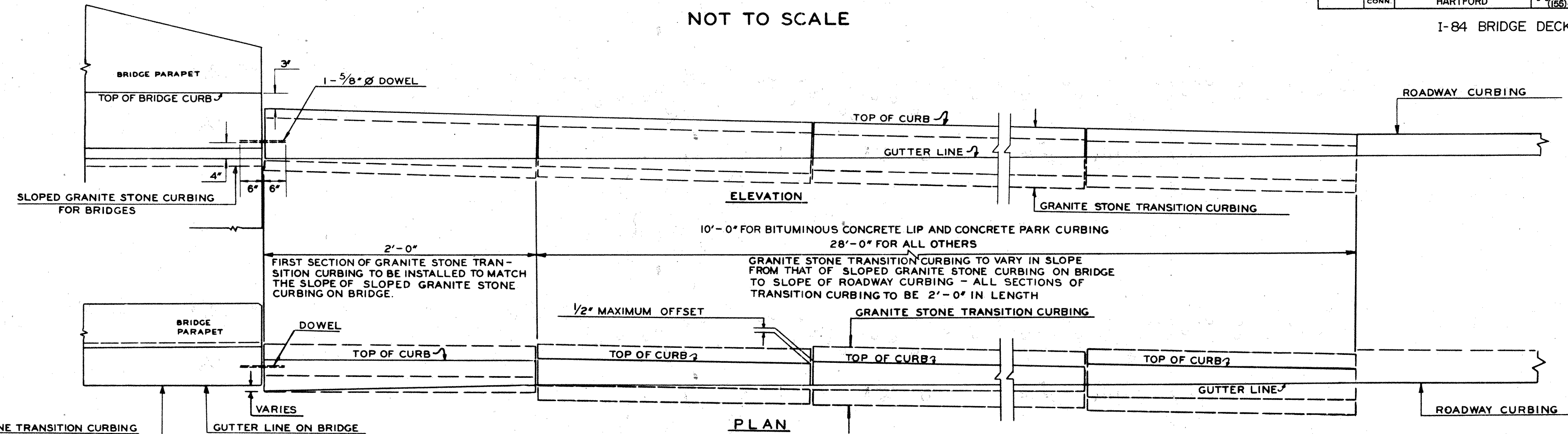

DETAIL SHOWING INSTALLATION OF GRANITE STONE TRANSITION CURBING BETWEEN BRIDGE CURBING AND ROADWAY CURBING

- NOTE:
- 1) GRANITE STONE TRANSITION CURBING WILL BE INSTALLED AS NOTED ON THE PLANS AND ACCORDING TO THE PERTINENT SPECIFICATIONS FOR "GRANITE SLOPE CURBING".
 - 2) GRANITE STONE TRANSITION CURBING (INCLUDING DOWEL) WILL BE PAID FOR AT THE CONTRACT UNIT PRICE FOR "GRANITE SLOPE CURBING".

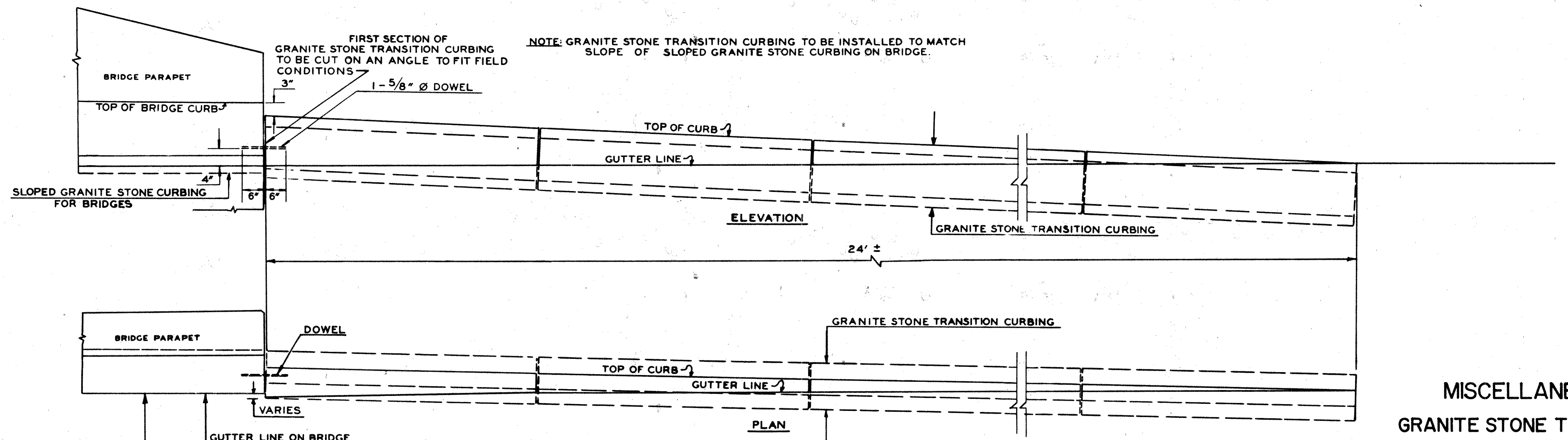
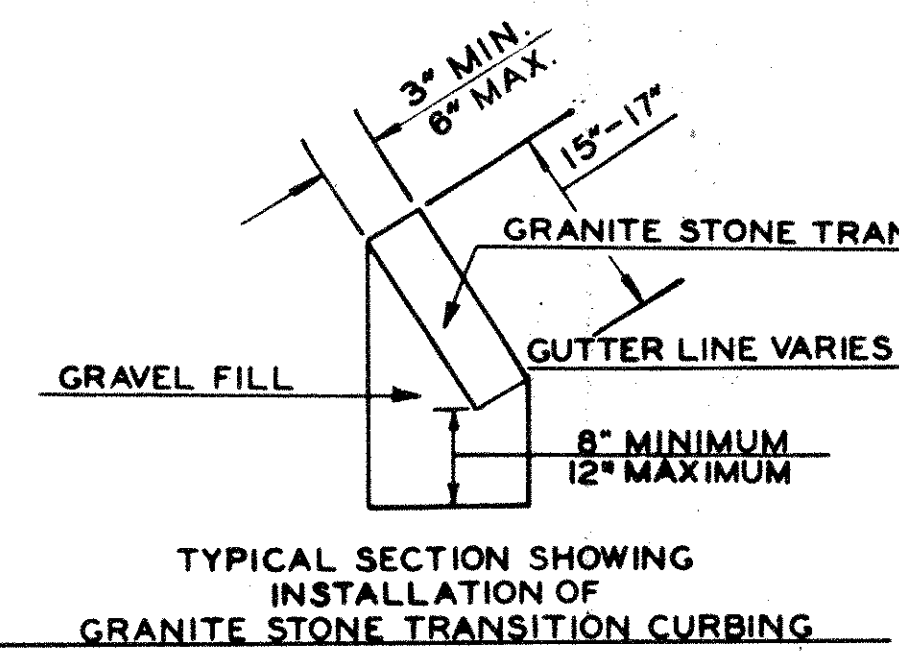

DETAIL SHOWING INSTALLATION OF GRANITE STONE TRANSITION CURBING ADJACENT TO BRIDGE CURBING (NO ADJACENT ROADWAY CURBING)

MISCELLANEOUS DETAILS GRANITE STONE TRANSITION CURBING

REVISIONS			
NO.	DATE	DESCRIPTION	REV. SHEET NO.

F.H.W.A. REGION	STATE	TOWN	FED. AID PROJ. NO.	PROJ. NO.	YEAR	ROUTE NO.	SHEET NO.	TOTAL SHEETS
1	CONN.	FARMINGTON	I-84-3(15)42	131-145	1982	I-84	101	115

ITEM	UNIT	QUANTITIES								TOTAL
		AMOUNT								
		BRIDGE NUMBERS								
		01237	01242	01750	03169	03310	03314	03315	03498	
Protective Fence (5' High)	L.F.	250	—	—	290	1080	481	466	425	2992
Protective Fence (7' High) (Curved)	L.F.	250	889	558	296	—	—	—	428	2421

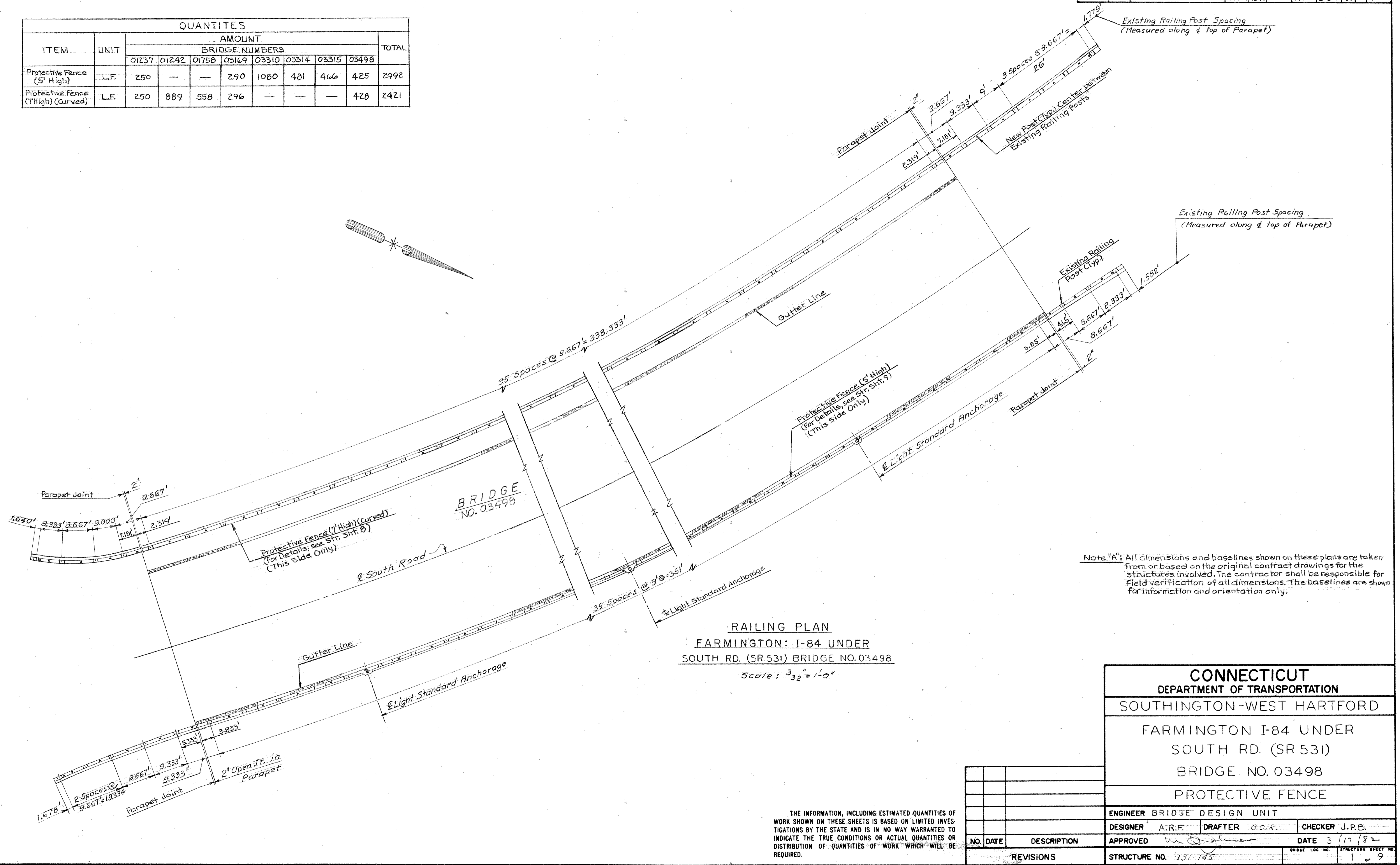

RAILING PLAN
FARMINGTON: I-84 UNDER
SOUTH RD. (SR.531) BRIDGE NO.03498
 Scale: 3/32" = 1'-0"

Note "A": All dimensions and baselines shown on these plans are taken from or based on the original contract drawings for the structures involved. The contractor shall be responsible for field verification of all dimensions. The baselines are shown for information and orientation only.

CONNECTICUT			
DEPARTMENT OF TRANSPORTATION			
SOUTHINGTON-WEST HARTFORD			
FARMINGTON I-84 UNDER			
SOUTH RD. (SR 531)			
BRIDGE NO. 03498			
PROTECTIVE FENCE			
ENGINEER BRIDGE DESIGN UNIT			
DESIGNER	A.R.F.	DRAFTER	G.O.K.
CHECKER	J.P.B.		
NO. DATE	DESCRIPTION	APPROVED	DATE 3/17/82
REVISIONS		STRUCTURE NO. 131-145	BRIDGE LOG NO. 1 of 9

THE INFORMATION, INCLUDING ESTIMATED QUANTITIES OF WORK SHOWN ON THESE SHEETS IS BASED ON LIMITED INVESTIGATIONS BY THE STATE AND IS IN NO WAY WARRANTED TO INDICATE THE TRUE CONDITIONS OR ACTUAL QUANTITIES OR DISTRIBUTION OF QUANTITIES OF WORK WHICH WILL BE REQUIRED.

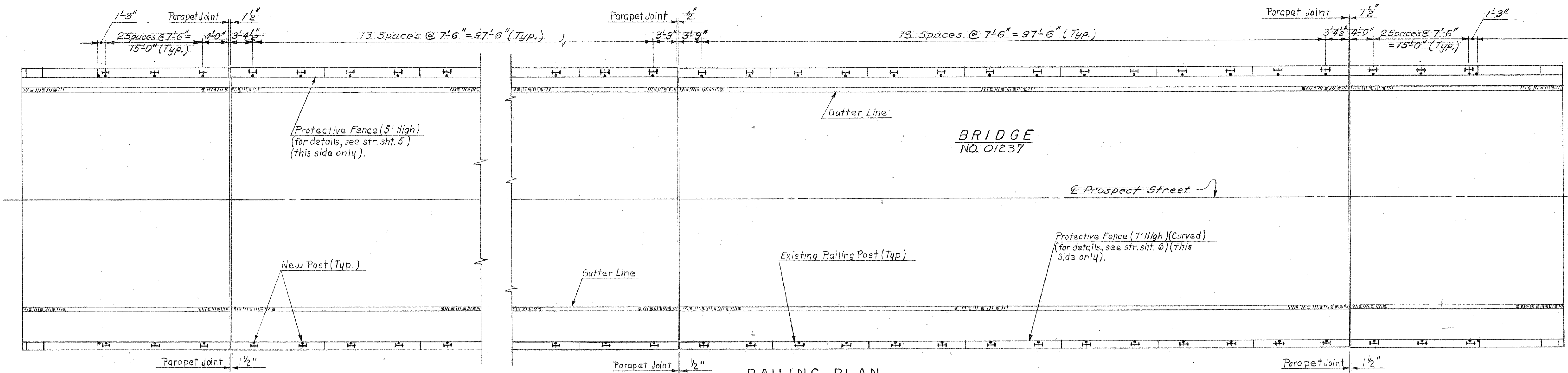
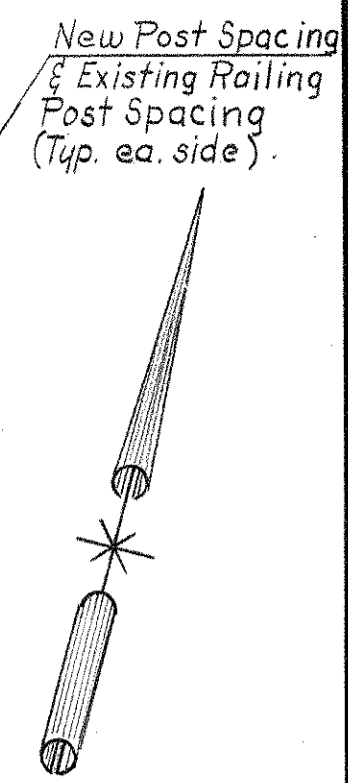

RAILING PLAN
SOUTHINGTON I-84 UNDER
PROSPECT STREET

NOTE: See Note "A", str. sht. 1.

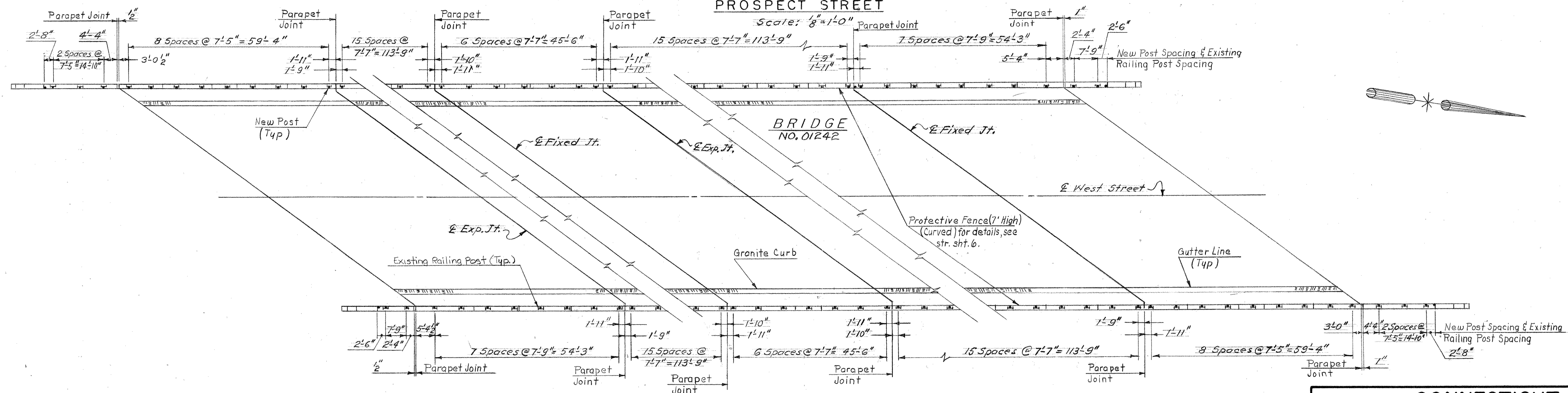

RAILING PLAN
SOUTHINGTON I-84 UNDER WEST STREET
Scale: 1" = 15'

CONNECTICUT			
DEPARTMENT OF TRANSPORTATION			
SOUTHINGTON-WEST HARTFORD			
SOUTHINGTON I-84 UNDER PROSPECT ST. BR. NO. 01237			
SOUTHINGTON I-84 UNDER WEST ST. (RT. 229) BR. NO. 01242			
PROTECTIVE FENCE			
ENGINEER BRIDGE DESIGN UNIT			
DESIGNER	A.R.F.	DRAFTER	G.O.K.
CHECKER	J.P.B.		
NO.	DATE	DESCRIPTION	APPROVED
			DATE 3/17/82
REVISIONS		STRUCTURE NO. 131-145-1237 & 1242	BRIDGE LOG NO. 01237-01242
		STRUCTURE SHEET NO. 2	9

THE INFORMATION, INCLUDING ESTIMATED QUANTITIES OF WORK SHOWN ON THESE SHEETS IS BASED ON LIMITED INVESTIGATIONS BY THE STATE AND IS IN NO WAY WARRANTED TO INDICATE THE TRUE CONDITIONS OR ACTUAL QUANTITIES OR DISTRIBUTION OF QUANTITIES OF WORK WHICH WILL BE REQUIRED.

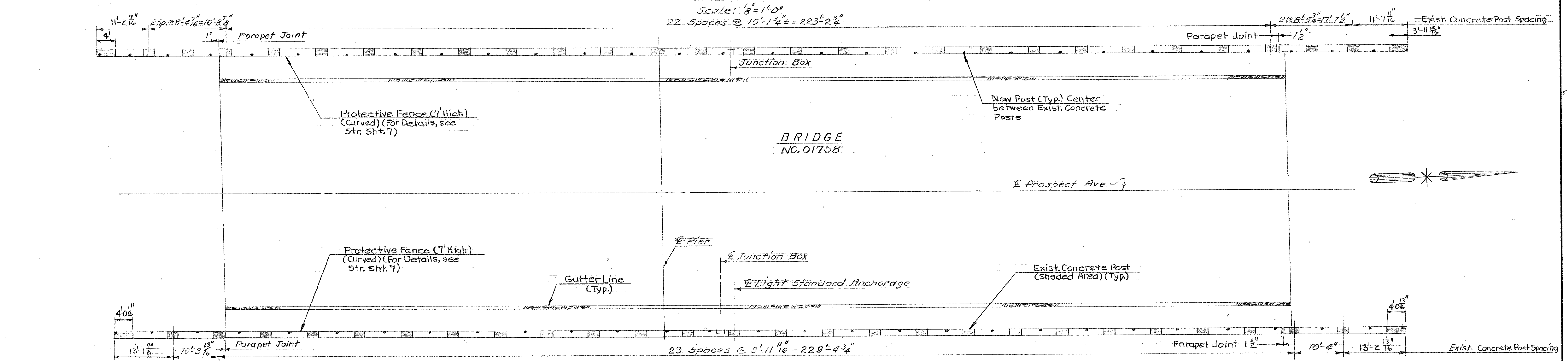
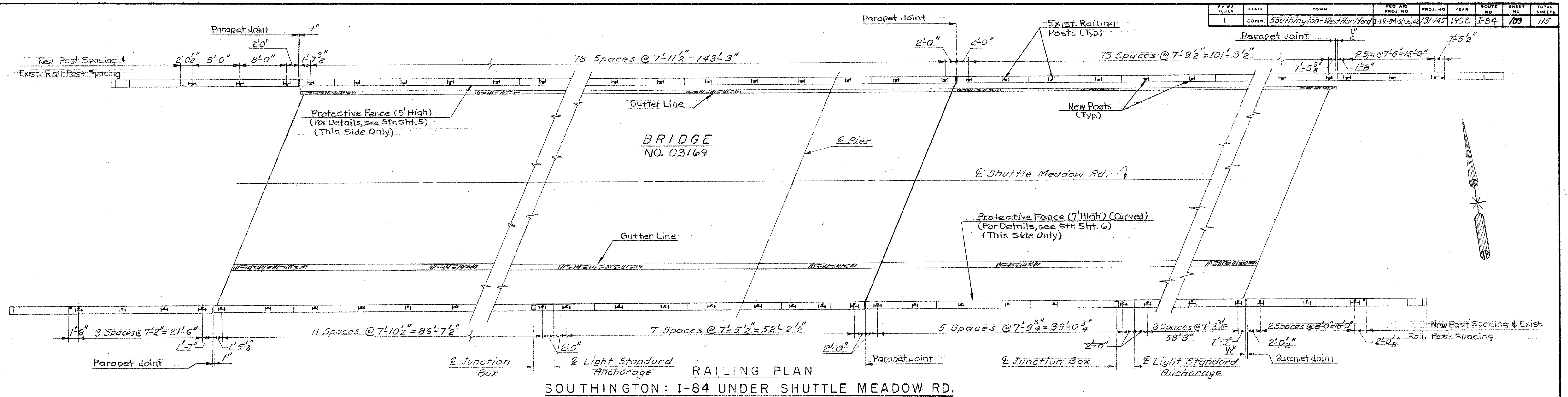

RAILING PLAN
 WEST HARTFORD: I-84 UNDER PROSPECT AVENUE
 Scale: 1"=1'-0"

See NOTE "A" Str. Sht. 1

THE INFORMATION, INCLUDING ESTIMATED QUANTITIES OF WORK SHOWN ON THESE SHEETS IS BASED ON LIMITED INVESTIGATIONS BY THE STATE AND IS IN NO WAY WARRANTED TO INDICATE THE TRUE CONDITIONS OR ACTUAL QUANTITIES OR DISTRIBUTION OF QUANTITIES OF WORK WHICH WILL BE REQUIRED.

NO.	DATE	DESCRIPTION

CONNECTICUT
 DEPARTMENT OF TRANSPORTATION

SOUTHINGTON-WEST HARTFORD
 SOUTHINGTON I-84 UNDER
 SHUTTLE MEADOW RD.-BR. NO. 03169
 WEST HARTFORD I-84 UNDER
 PROSPECT AVE. BRIDGE NO. 01758

PROTECTIVE FENCE

ENGINEER BRIDGE DESIGN UNIT

DESIGNER A.R.E. DRAFTER G.O.K. CHECKER J.P.B.

APPROVED *[Signature]* DATE 3/17/82

BRIDGE LOG NO. 03169-01758 STRUCTURE SHEET NO. 3 of 9

F.H.W.A. REGION	STATE	TOWN	FED. AID PROJ. NO.	PROJ. NO.	YEAR	ROUTE NO.	SHEET NO.	TOTAL SHEETS
1	CONN.	PLAINVILLE & NEW BRITAIN	E-30-843(033)42	131-145	1982	I-84	104	115

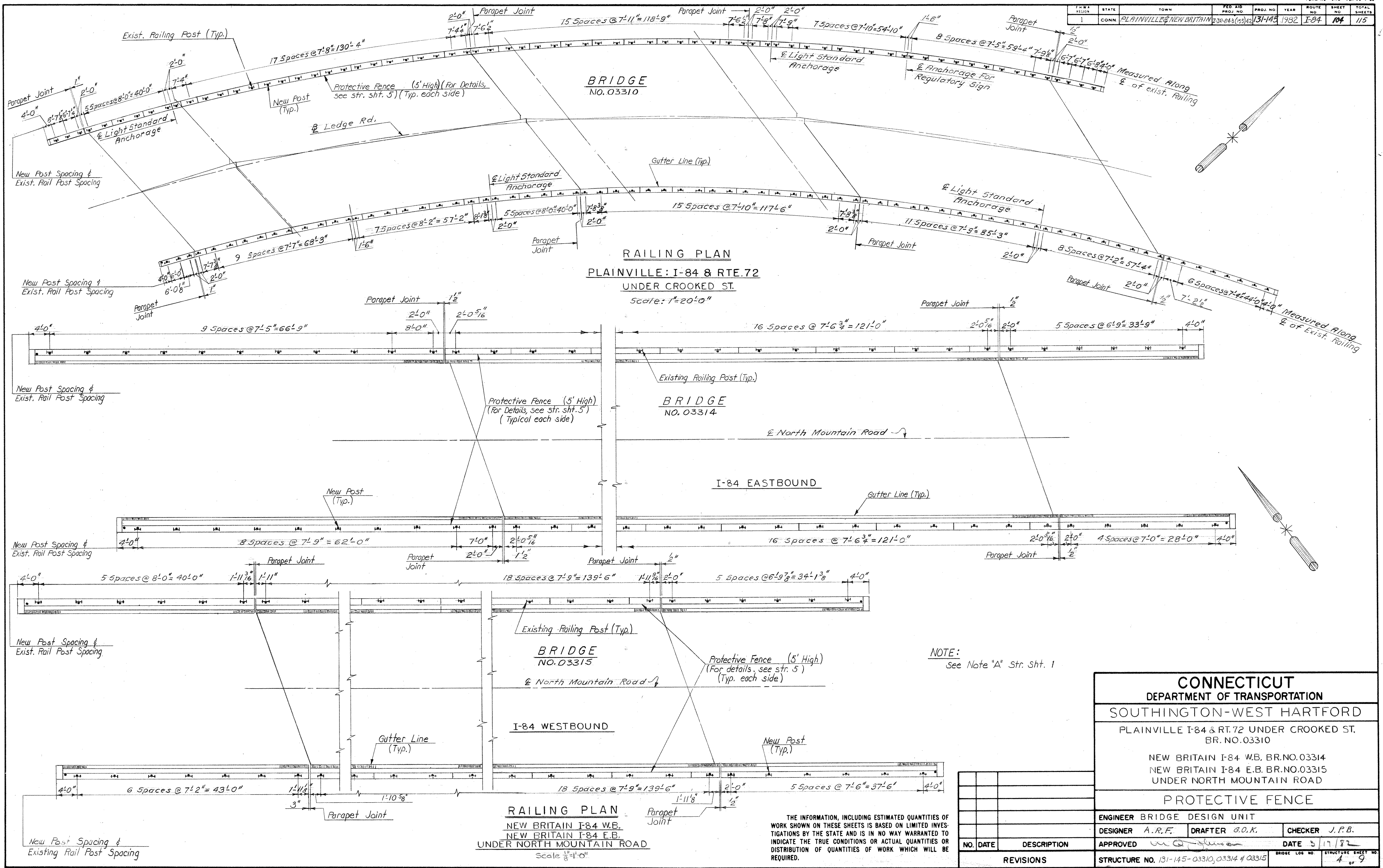

CONNECTICUT		
DEPARTMENT OF TRANSPORTATION		
SOUTHINGTON-WEST HARTFORD		
PLAINVILLE I-84 & RT. 72 UNDER CROOKED ST. BR. NO. 03310		
NEW BRITAIN I-84 W.B. BR. NO. 03314 NEW BRITAIN I-84 E.B. BR. NO. 03315 UNDER NORTH MOUNTAIN ROAD		
PROTECTIVE FENCE		
ENGINEER BRIDGE DESIGN UNIT		
DESIGNER A.R.F.	DRAFTER G.O.K.	CHECKER J.P.B.
APPROVED <i>[Signature]</i>	DATE 5/17/82	
STRUCTURE NO. 131-145-03310, 03314 & 03315		
BRIDGE LOG NO.		STRUCTURE SHEET NO.
		4 of 9

For Existing Spacing Dimensions see:
 Br. No. 01237 Southington; I-84 under Prospect St. Str. Sht. 2
 Br. No. 03169 Southington; I-84 under Shuttle Meadow Rd. Str. Sht. 3

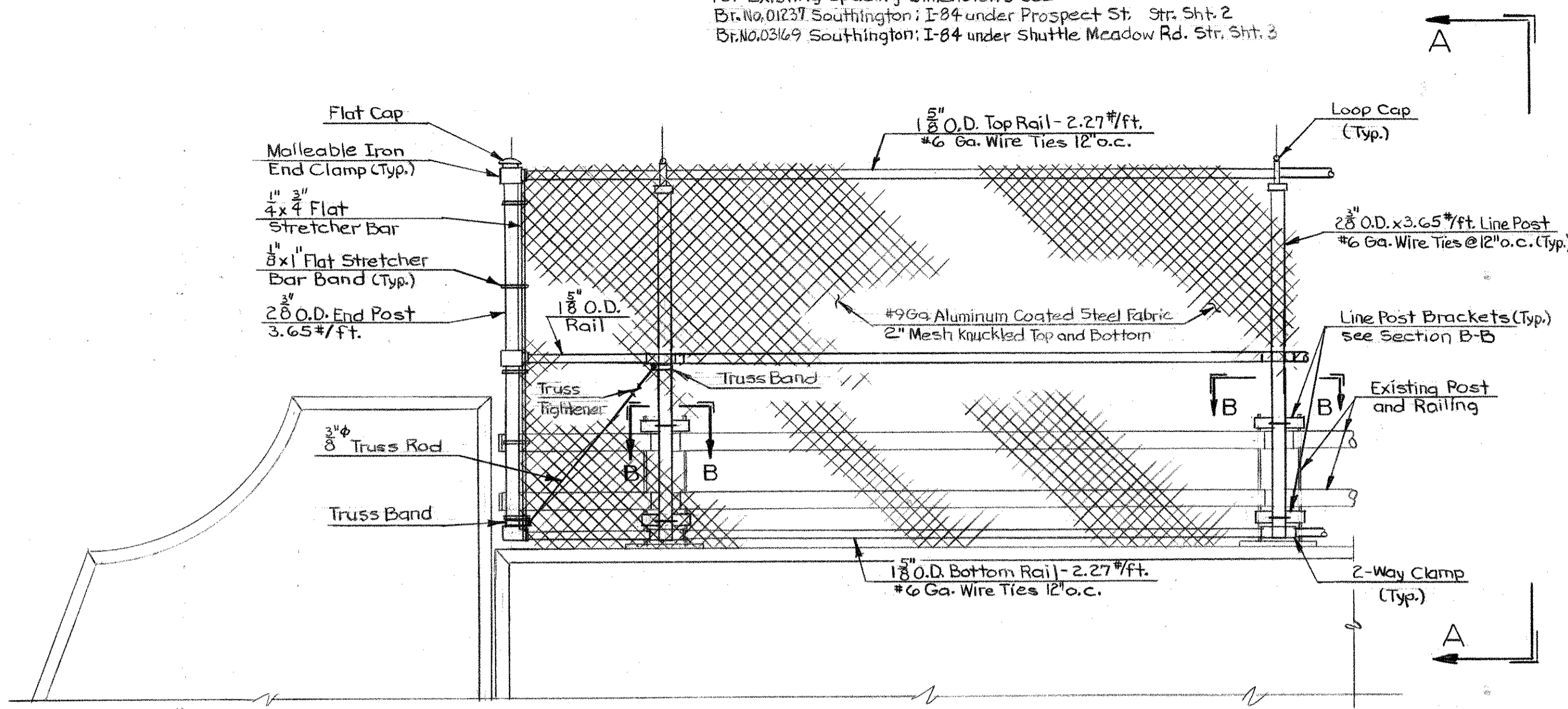

ELEVATION
END OF PARAPET TYPE-1
 Scale 3/4"=1'-0"
 BRIDGE NO'S. 01237 & 03169 ONLY

NOTE:
 Line Posts and End Posts shall be Vertical,
 All Rails shall be Parallel to Grade.

For Existing Spacing Dimensions see:
 Br. No. 03310 Plainville; I-84 RTE. 72 under Crooked St. Str. Sht. 4
 Br. No. 03314 & 03315 New Britain; I-84 under No. Mountain Rd. Str. Sht. 4

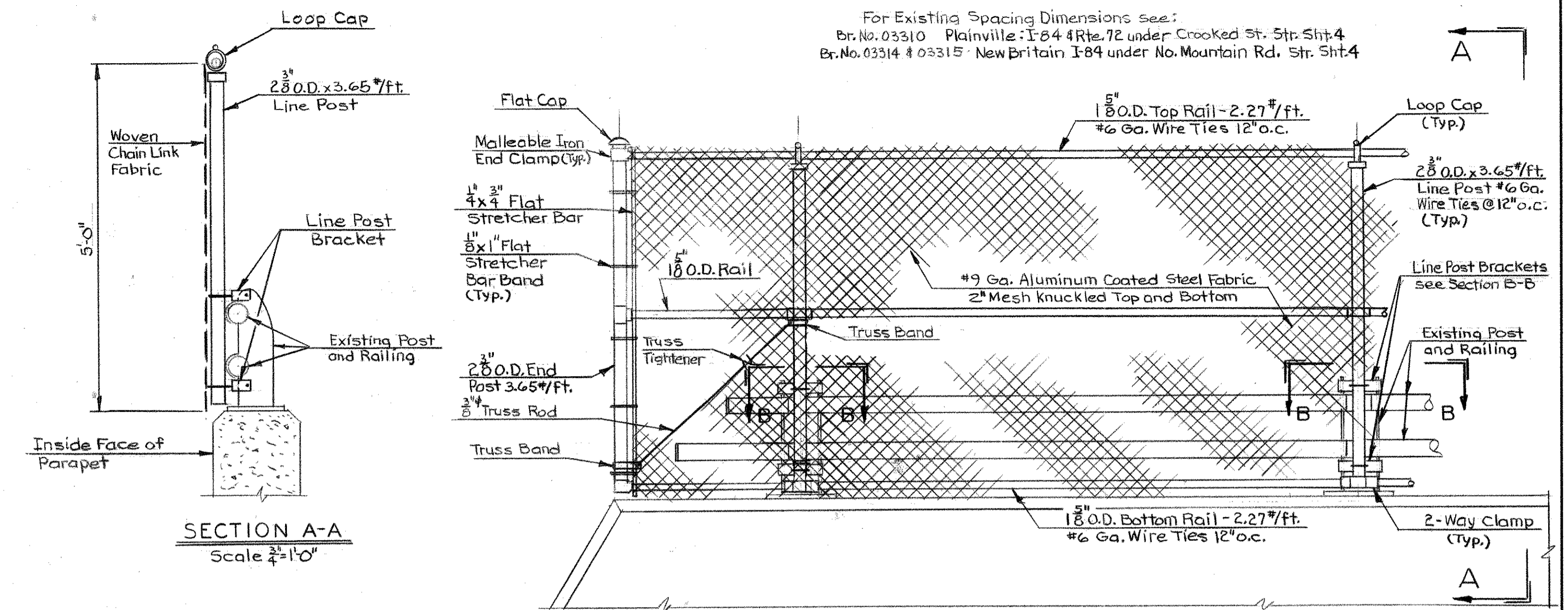

ELEVATION
END OF PARAPET TYPE-2
 Scale 3/4"=1'-0"
 BRIDGE NO'S. 03310, 03314 & 03315 ONLY

NOTE: For Parapet Joint Locations
 See Appropriate Railing Plans
 On Str. Shts. 2, 3 & 4.

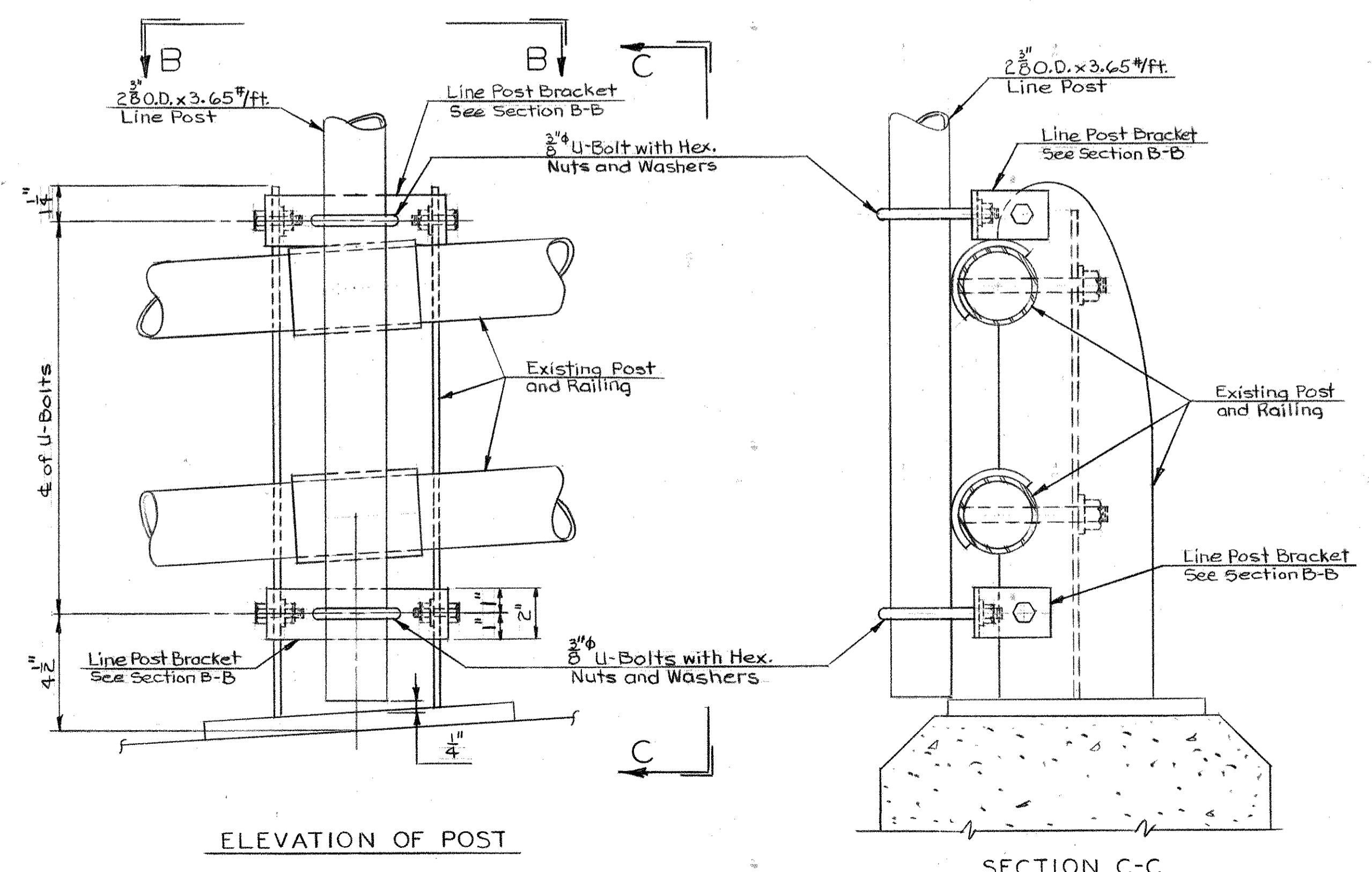
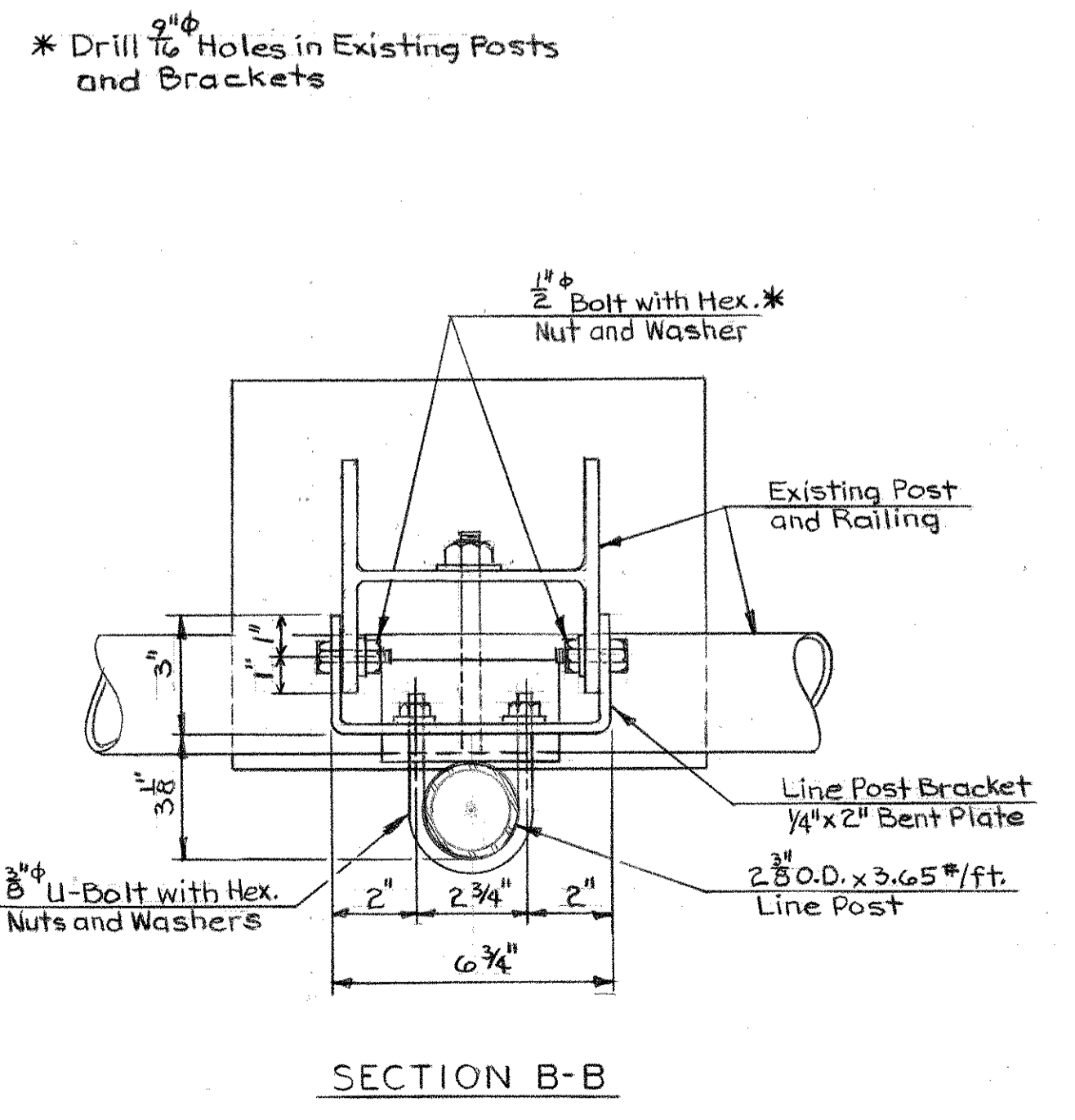
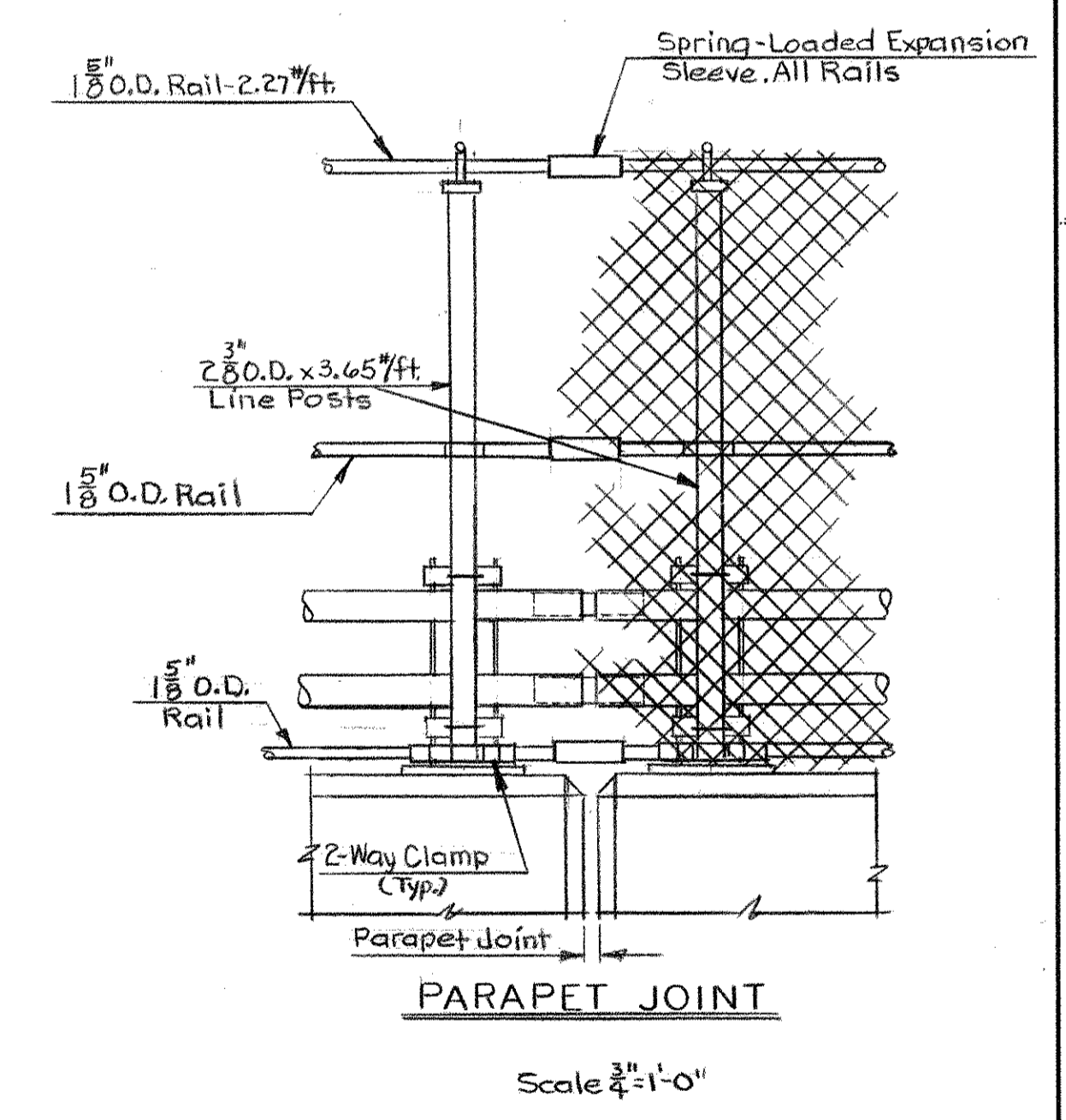

ELEVATION OF POST
PROTECTIVE FENCE CONNECTION DETAILS
 Scale 3/4"=1'-0"

CONNECTICUT
DEPARTMENT OF TRANSPORTATION
 SOUTHINGTON-WEST HARTFORD
 SOUTHINGTON I-84 UNDER PROSPECT ST. BR. NO. 01237
 SOUTHINGTON I-84 UNDER SHUTTLE MEADOW RD. BR. NO. 03169
 SOUTHINGTON I-84 & RTE. 72 UNDER CROOKED ST. BR. NO. 03310
 NEW BRITAIN I-84 UNDER NORTH MOUNTAIN RD. BR. NO. 03314 & 03315

ENGINEER Bridge Design Unit		CHECKER J.P.B.	
DESIGNER A.R.F.	DRAFTSMAN F.T.R.	DATE 2/17/82	
APPROVED <i>[Signature]</i>		STRUCTURE NO.	
REVISIONS		BRIDGE LOG NO.	STRUCTURE SHEET NO.
			5 of 9

For Existing Spacing Dimension see:
 Br. No. 01237 Southington: I-84 under Prospect St. Str. Sht. 2
 Br. No. 01242 Southington: I-84 under West St. Str. Sht. 2
 Br. No. 03169 Southington: I-84 under Shuttle Meadow Rd. Str. Sht. 3

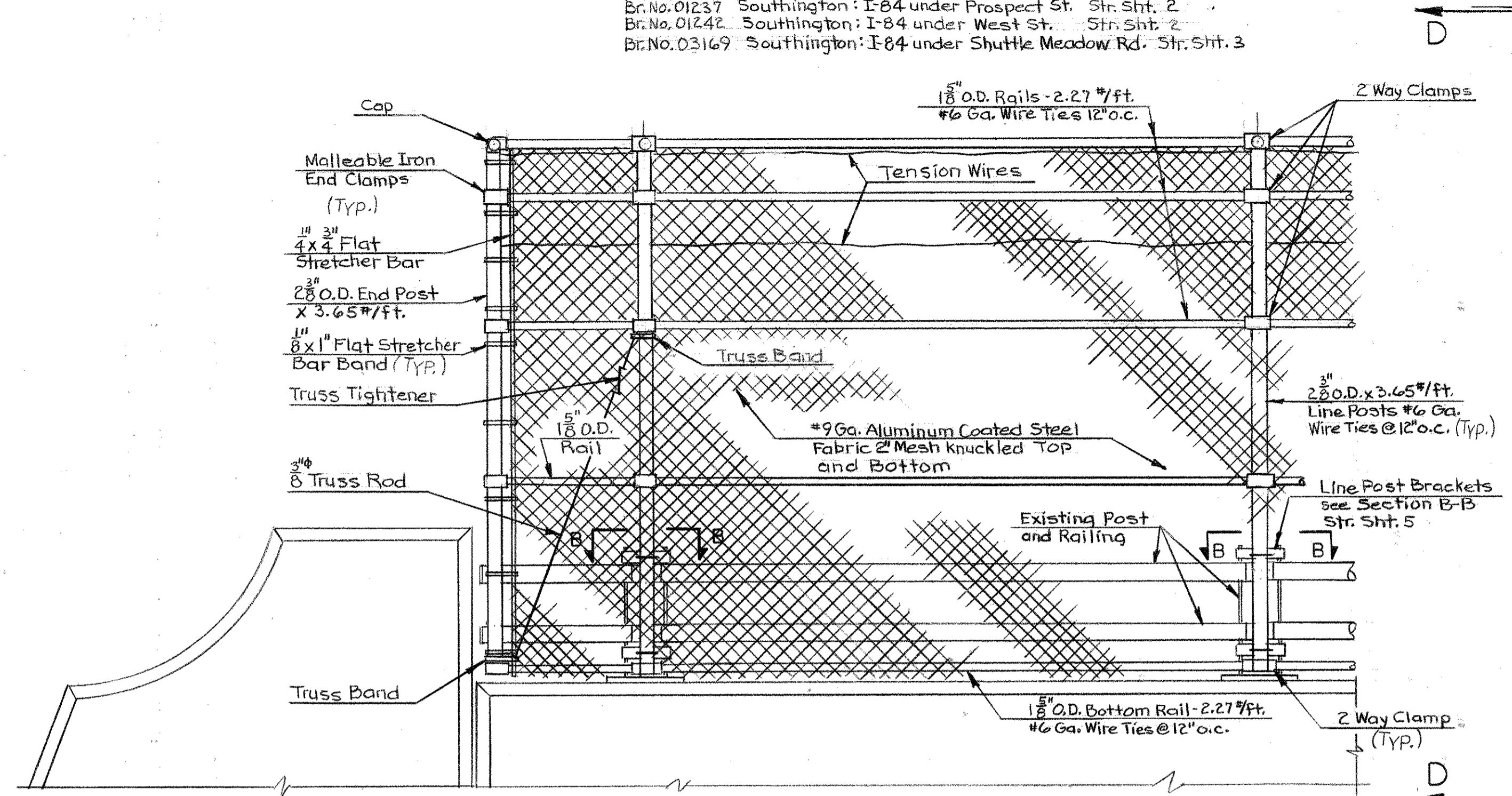

ELEVATION
END OF PARAPET
 Scale 3/4"=1'-0"

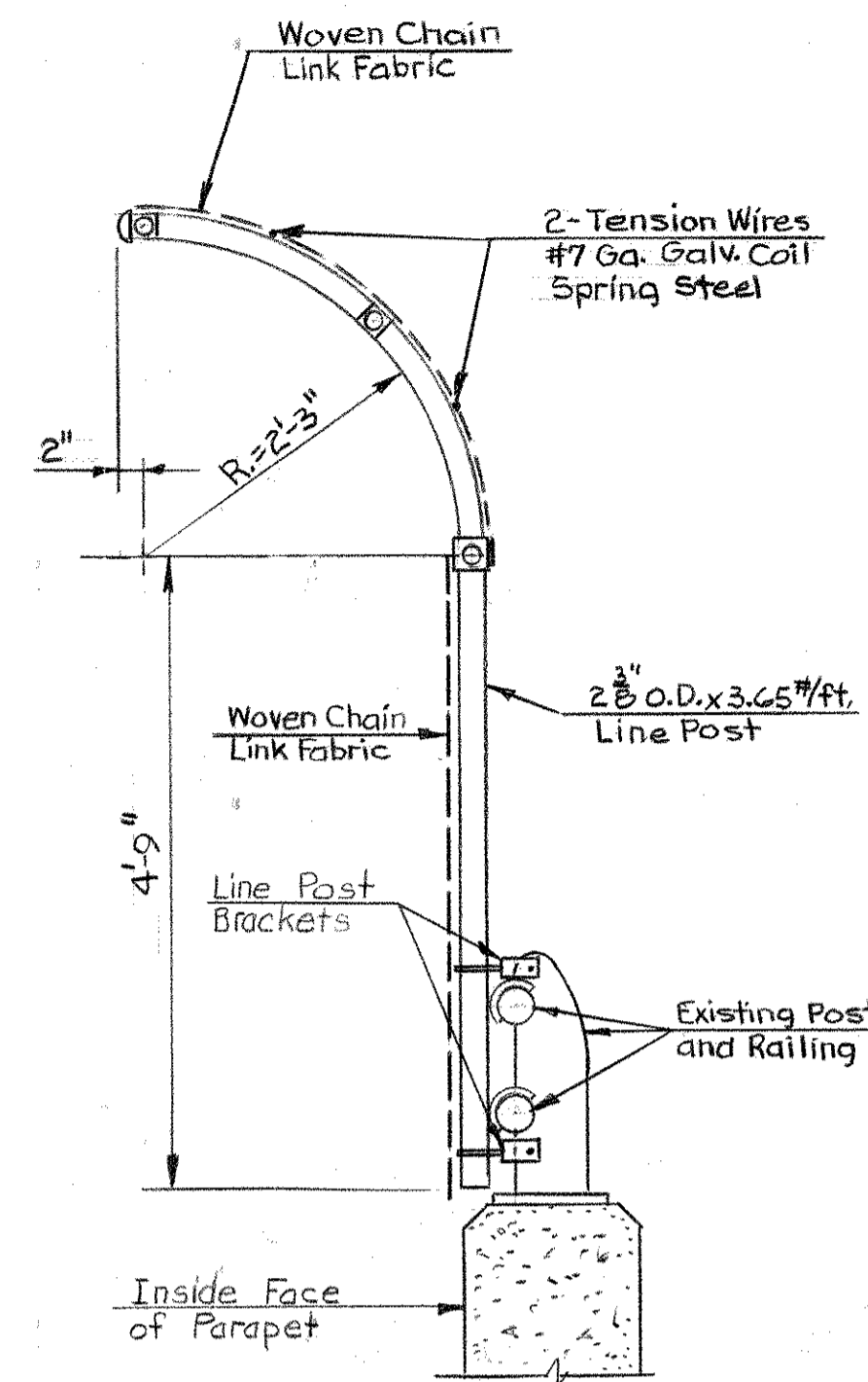

SECTION D-D
 Scale 3/4"=1'-0"

1. For Section B-B See Str. Sht. 5.
2. For Connection Details Not Shown See "Protective Fence Connection Details", Str. Sht. 5.

NOTE:
 Line Posts and End Posts shall be Vertical. All Rails shall be Parallel to Grade.

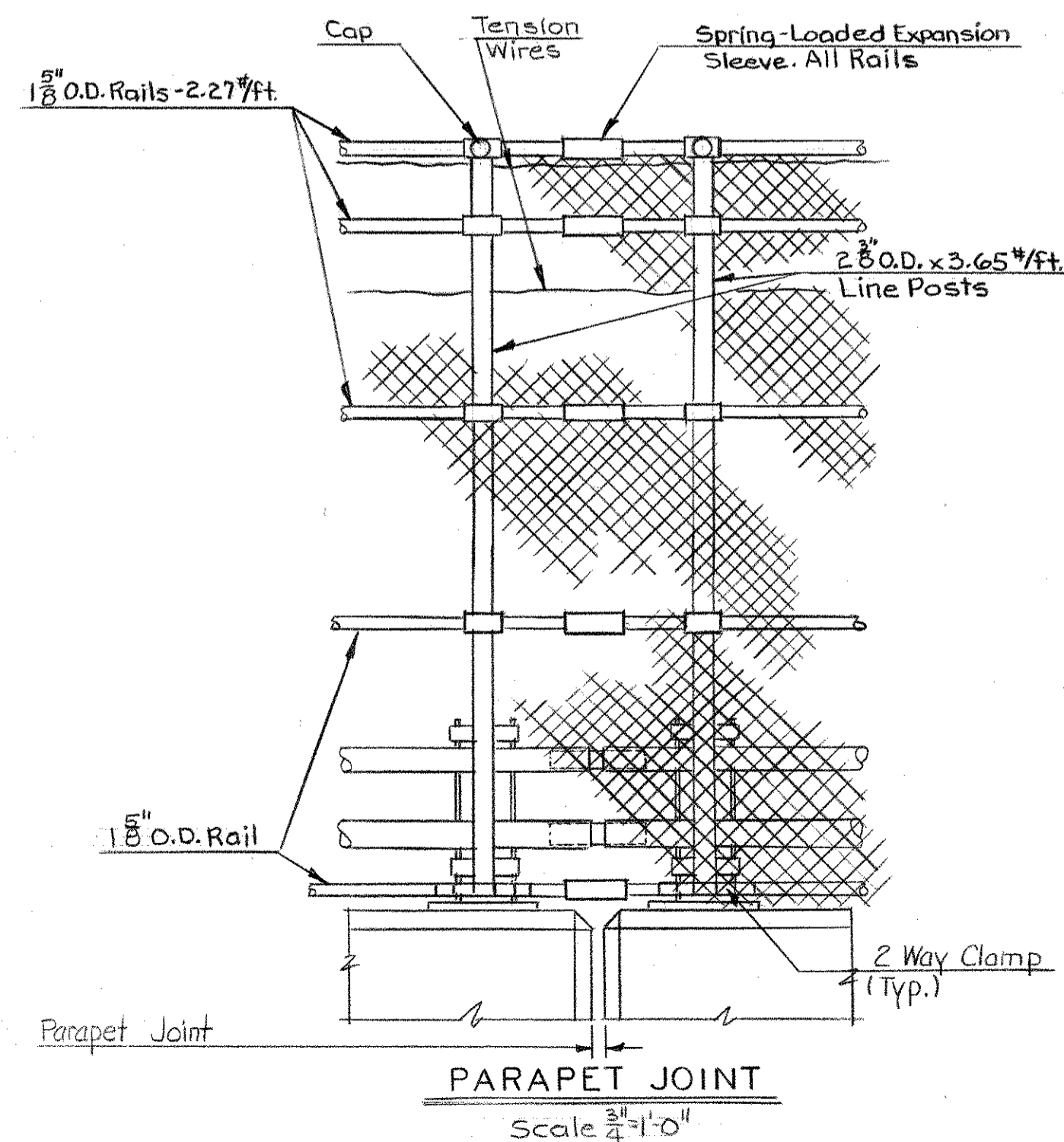

NOTE:
 For Parapet Locations See Appropriate Railing Plans on Str. Shts. 2 & 3.

CONNECTICUT		
DEPARTMENT OF TRANSPORTATION		
SOUTHINGTON-WEST HARTFORD		
SOUTHINGTON I-84 UNDER PROSPECT ST. BR. NO. 01237		
SOUTHINGTON I-84 UNDER WEST ST. BR. NO. 01242		
SOUTHINGTON I-84 UNDER SHUTTLE MEADOW RD. BR. NO. 03169		
PROTECTIVE FENCE (7' HIGH)(CURVED) DETAILS		
ENGINEER Bridge Design Unit		
DESIGNER A. R. F.	DRAFTSMAN F. T. R.	CHECKER J. P. B.
NO. DATE	DESCRIPTION	DATE 3/17/82
REVISIONS		STRUCTURE NO. 131-145
		BRIDGE LOG NO. STRUCTURE SHEET NO. 6 of 9

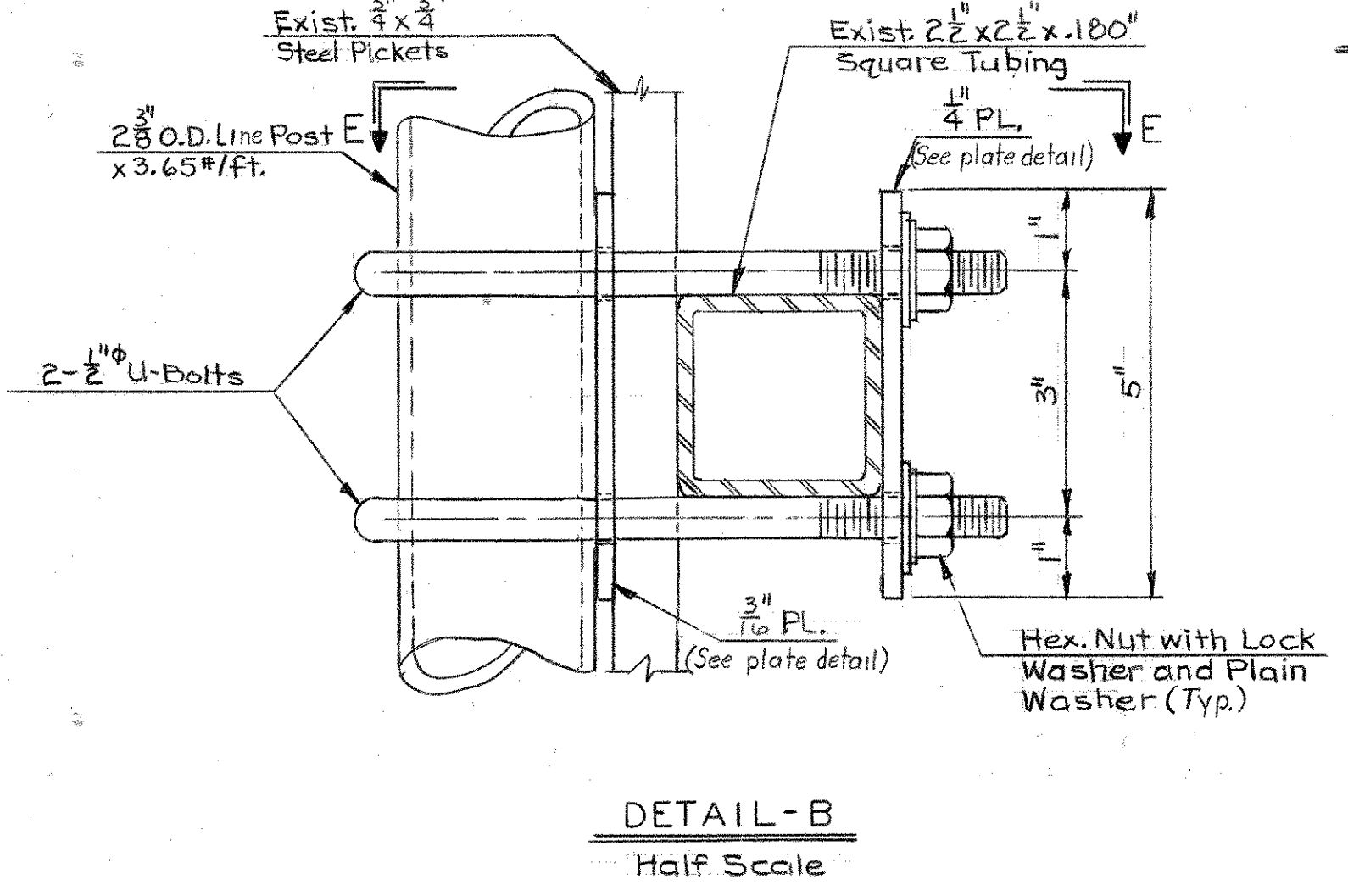
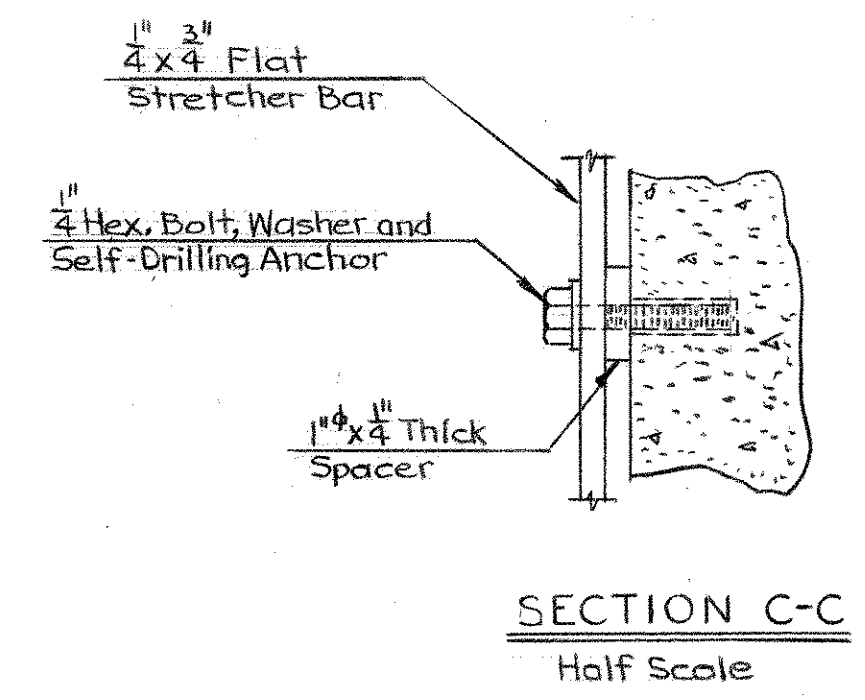
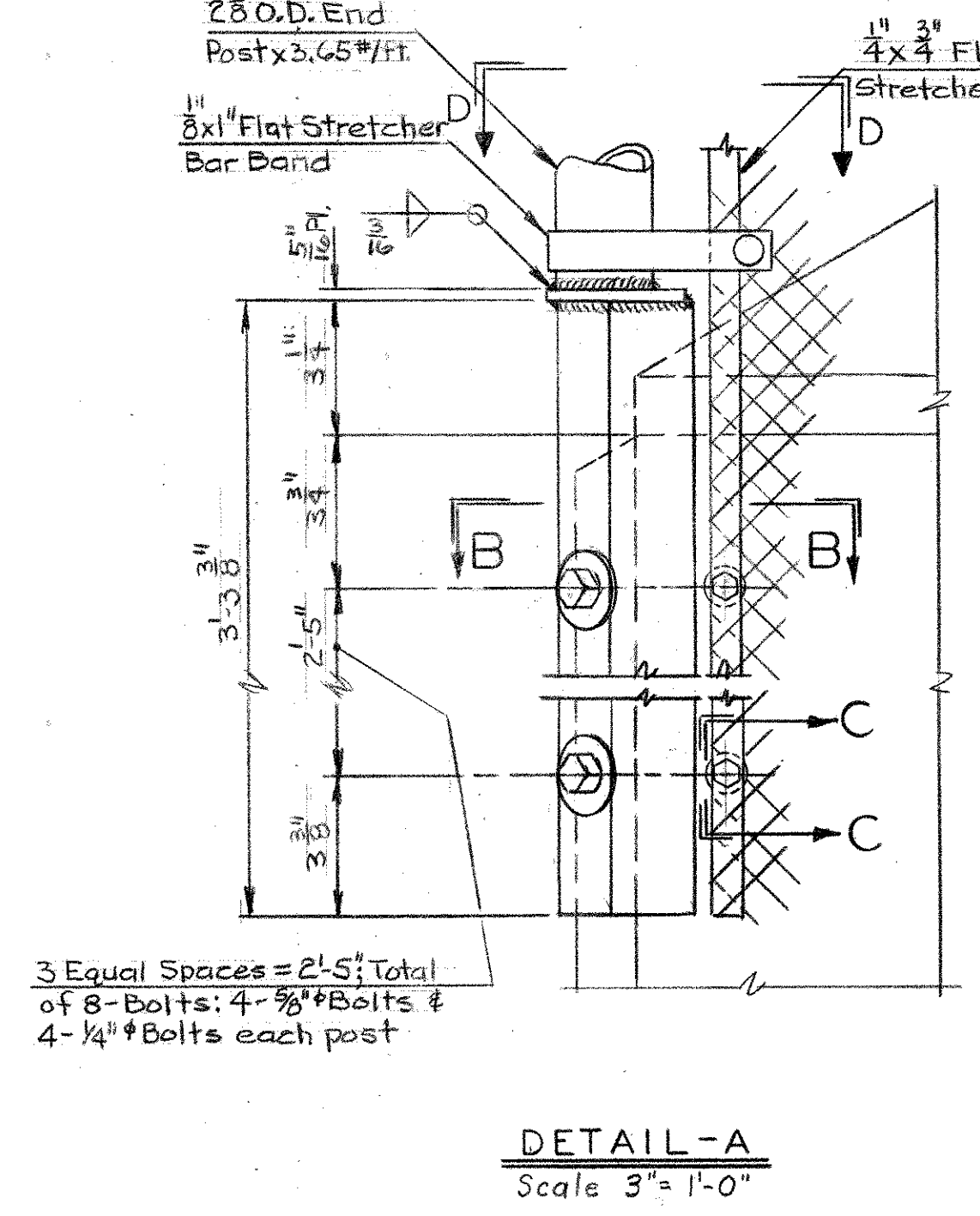
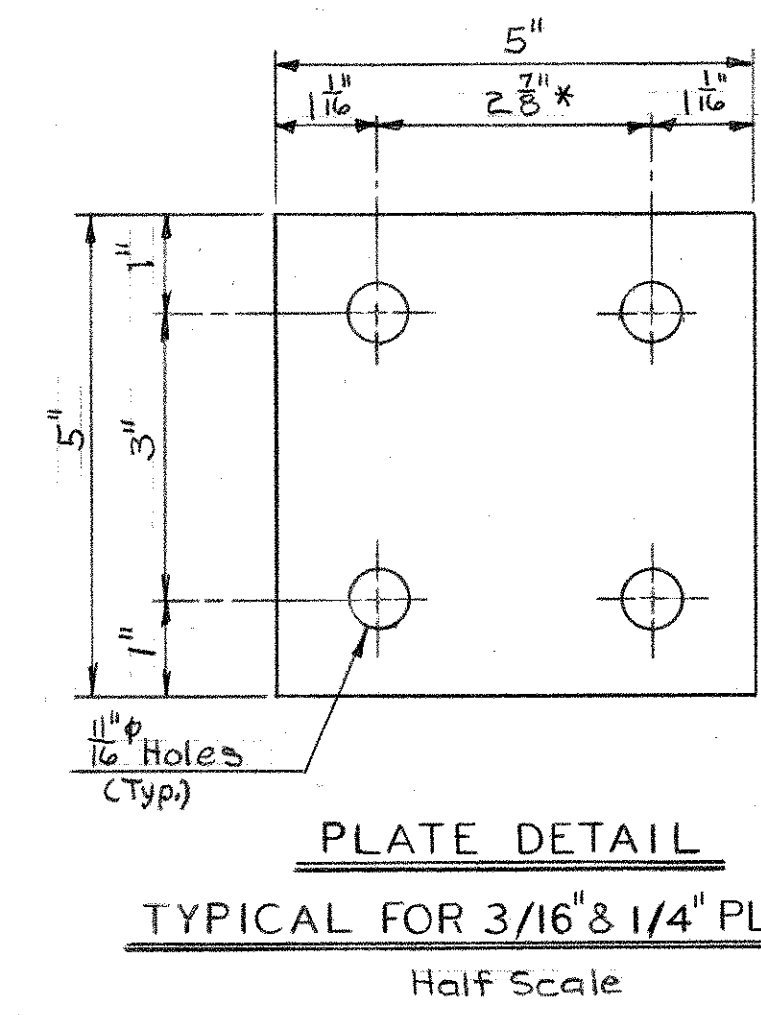
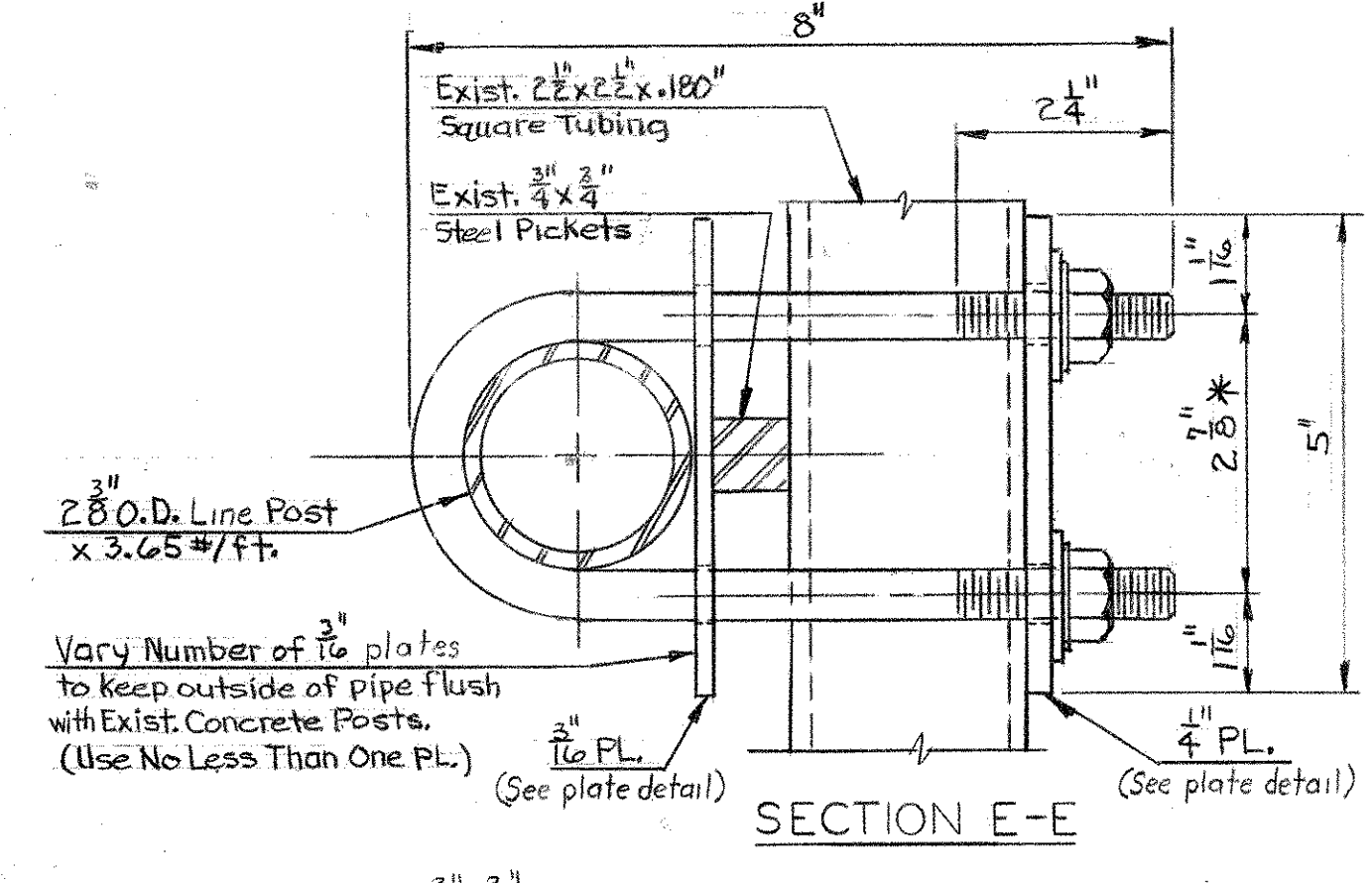
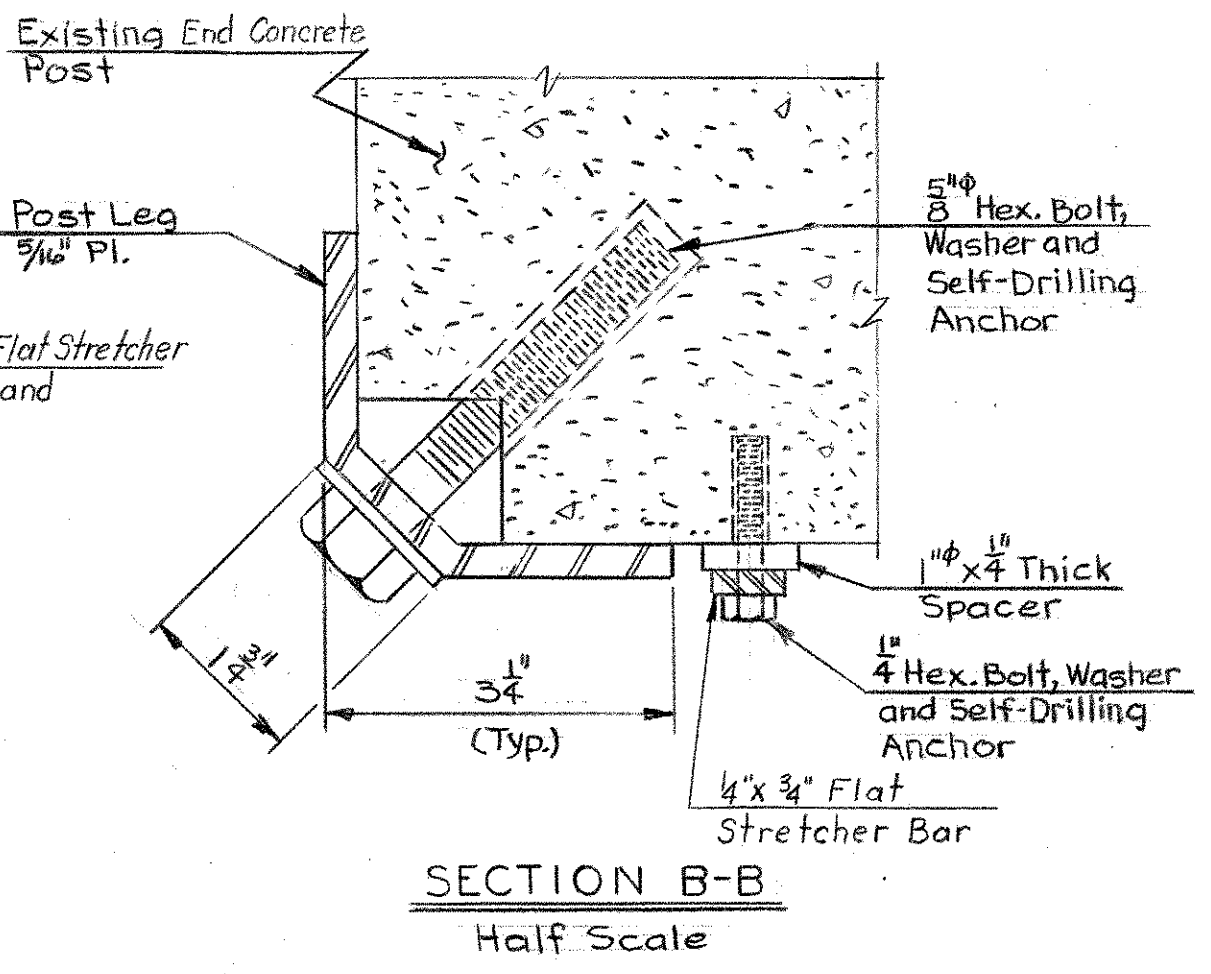
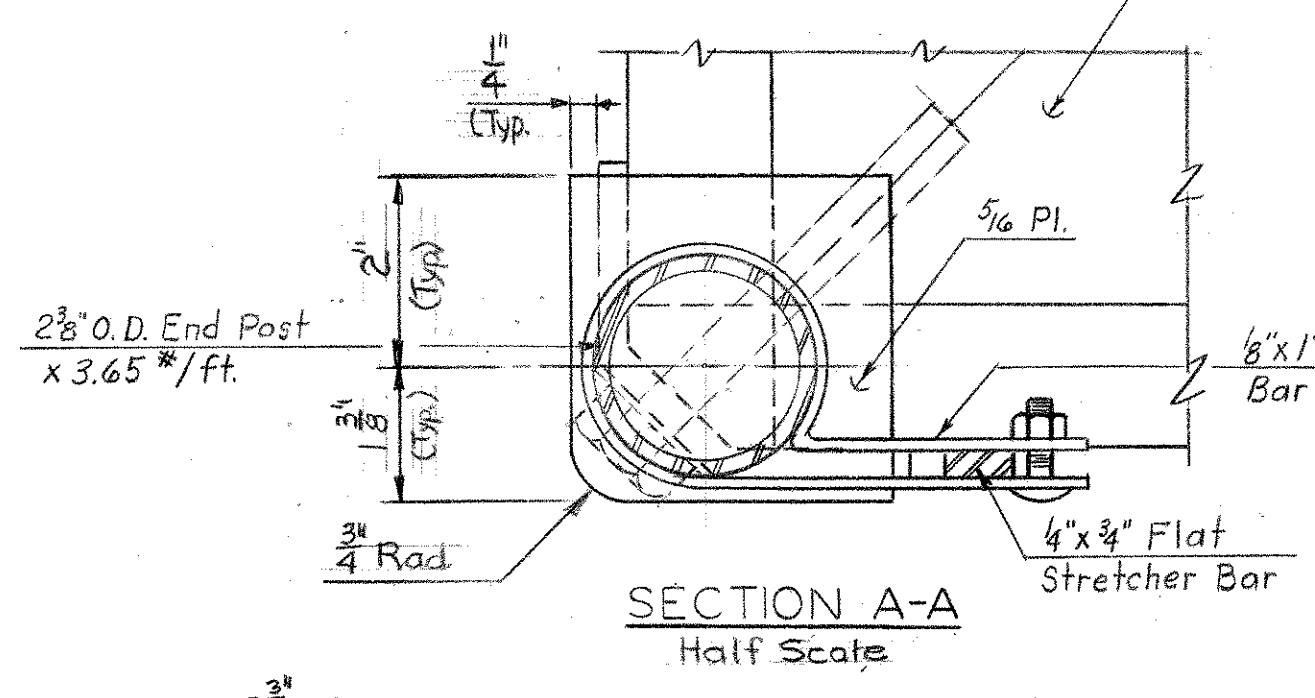
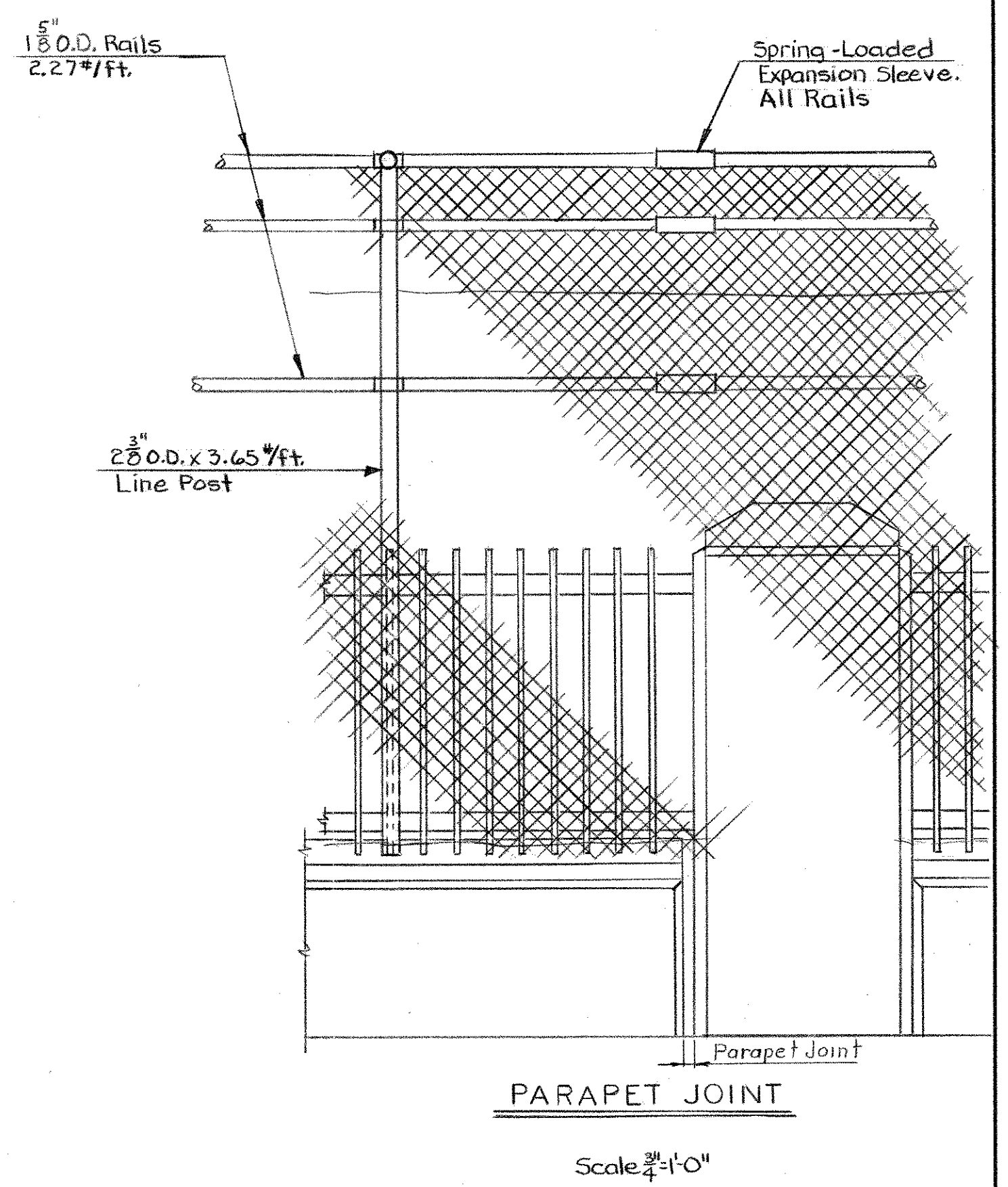
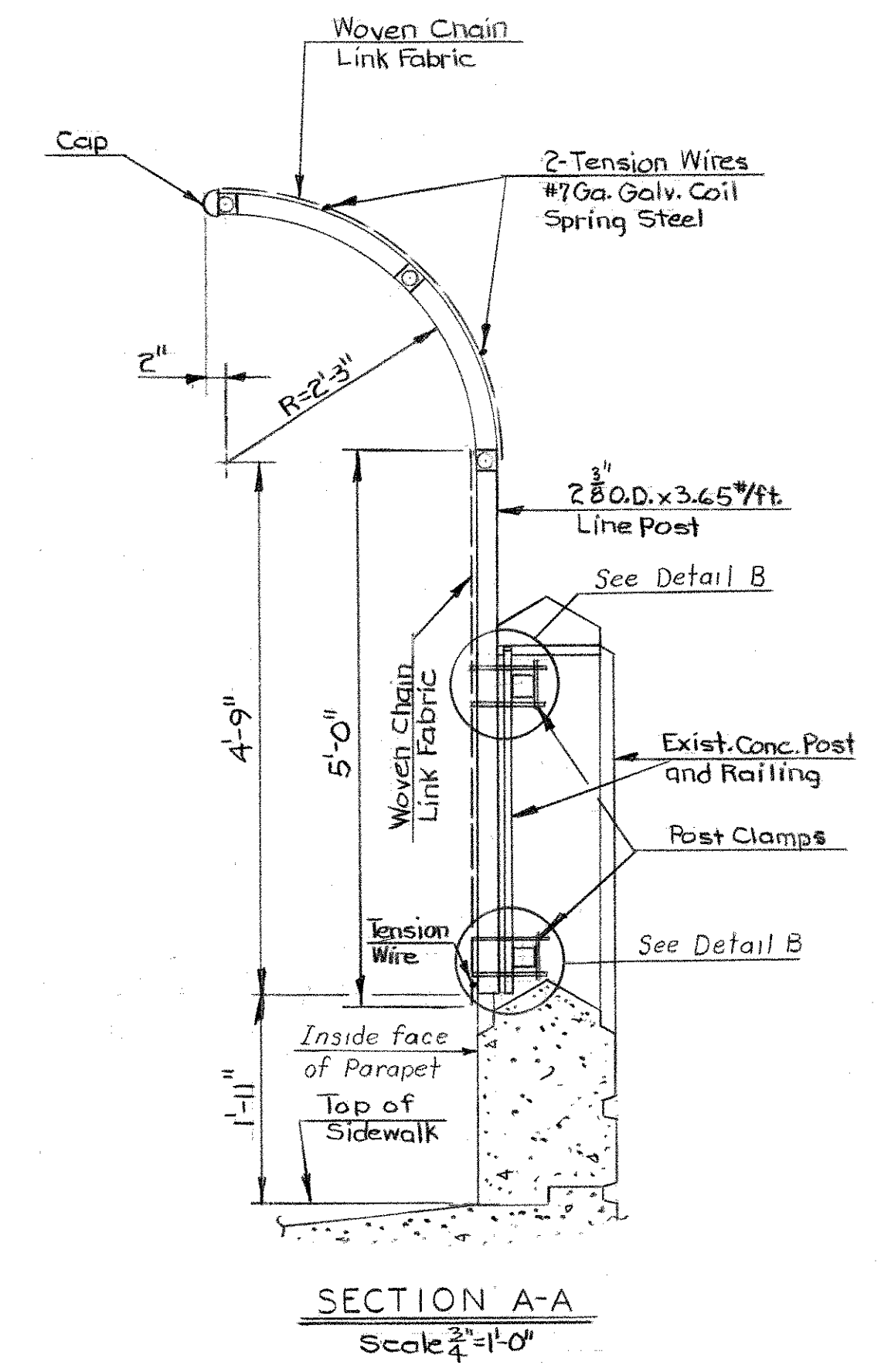
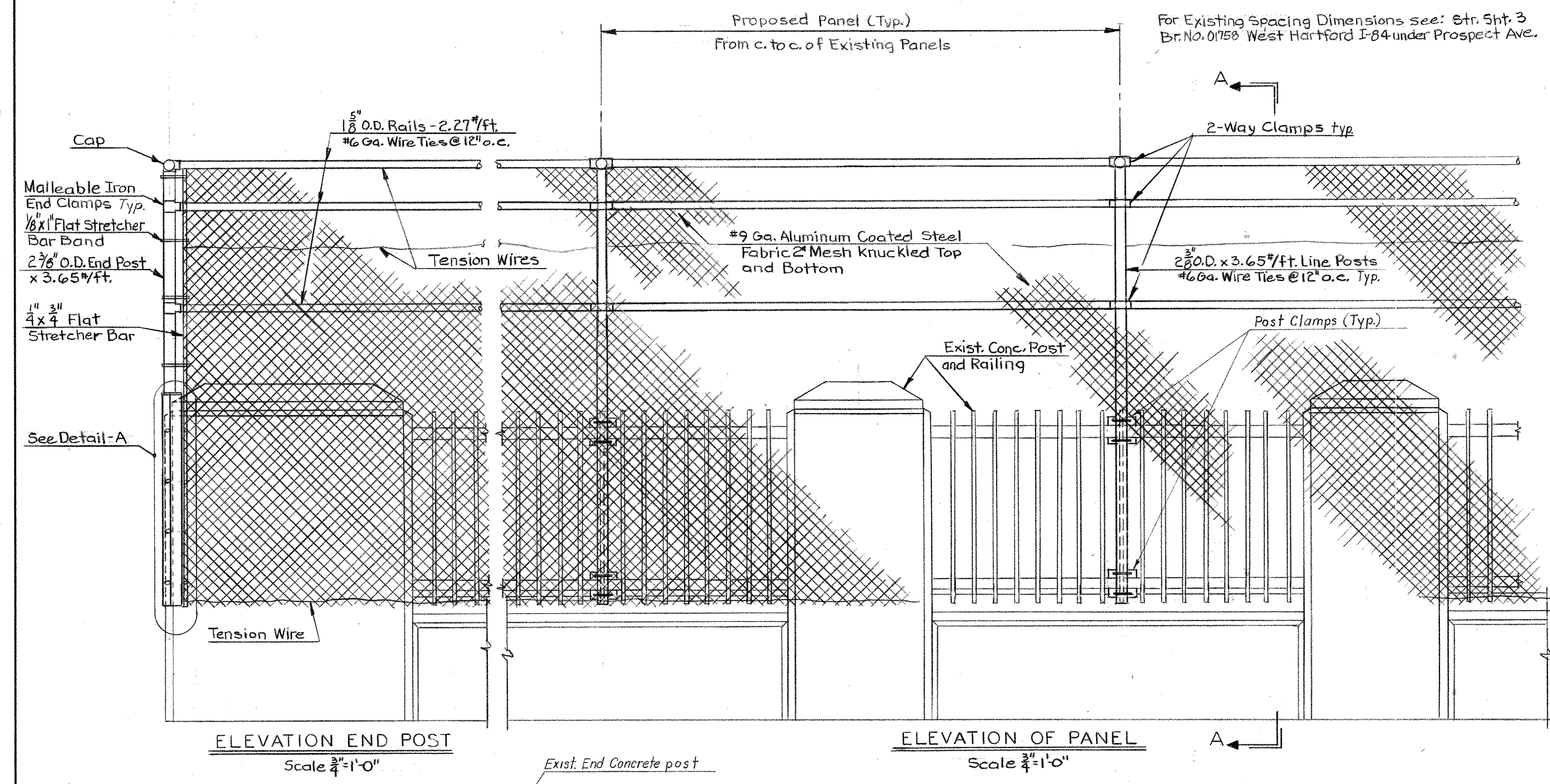

*Note: U-Bolt must fit snugly over Post after galvanizing. The 2 3/8" Dim. may be altered to suit this condition.

Note: For Parapet Joints Locations, see Bridge No. 01758, Str. Sht. 3.

CONNECTICUT			
DEPARTMENT OF TRANSPORTATION			
SOUTHINGTON-WEST HARTFORD			
WEST HARTFORD I 84 UNDER			
PROSPECT AVE.			
BRIDGE NO. 01758			
PROTECTIVE FENCE (7'-HIGH) (CURVED) DETAILS			
ENGINEER Bridge Design Unit			
DESIGNER A.R.F.	DRAFTSMAN F.T.R.	CHECKER J.P.B.	
APPROVED <i>[Signature]</i>	DATE 3/17/82		
STRUCTURE NO. 131-145-01758		BRIDGE LOG NO.	STRUCTURE SHEET NO.
		7	9

NO.	DATE	DESCRIPTION

For Spacing Dimensions see: Str. Sht. 1
Br. No. 03498 Farmington: I-84 under South Rd. (SR. 531)

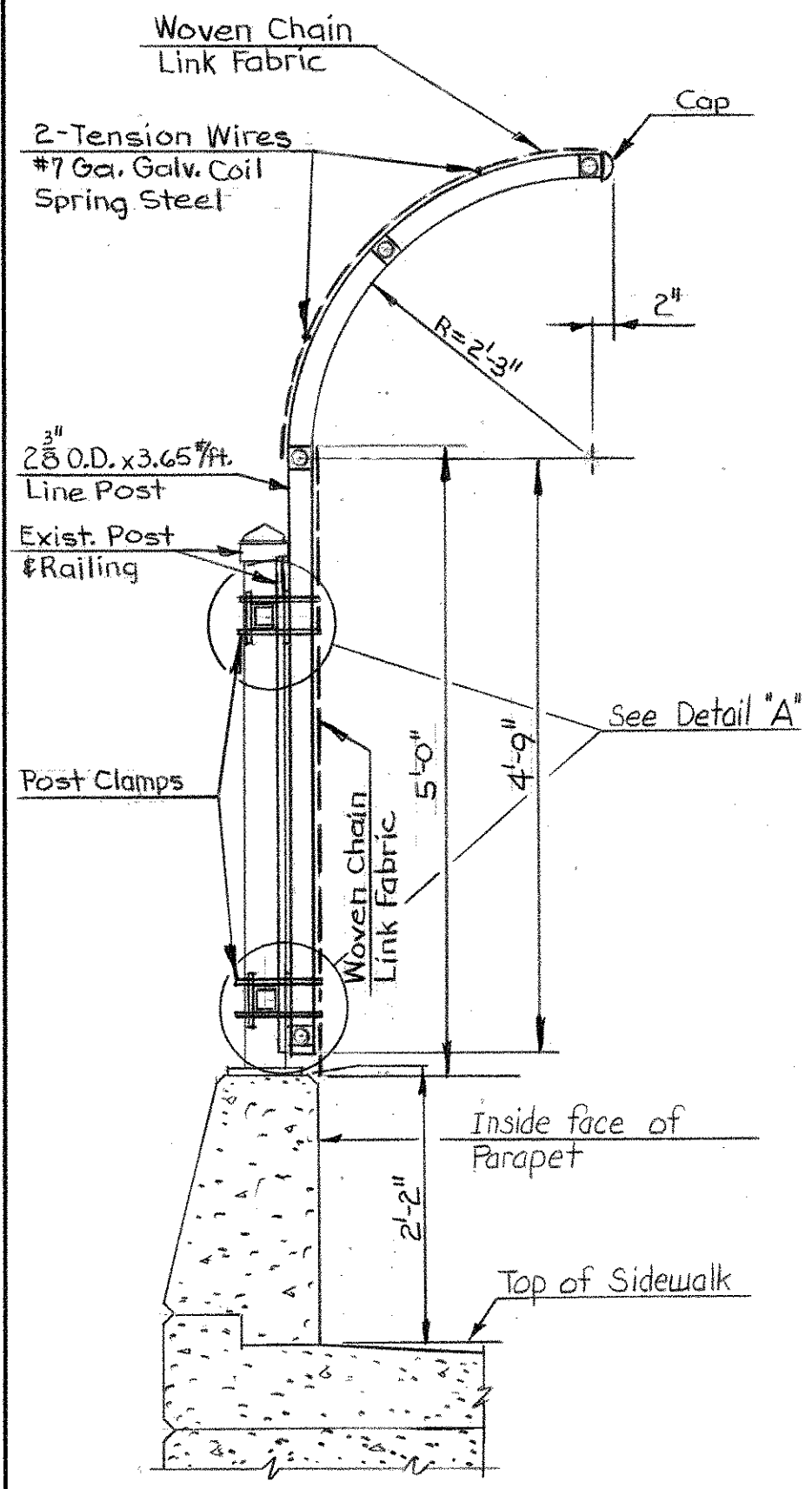

SECTION A-A
Scale 3/4"=1'-0"

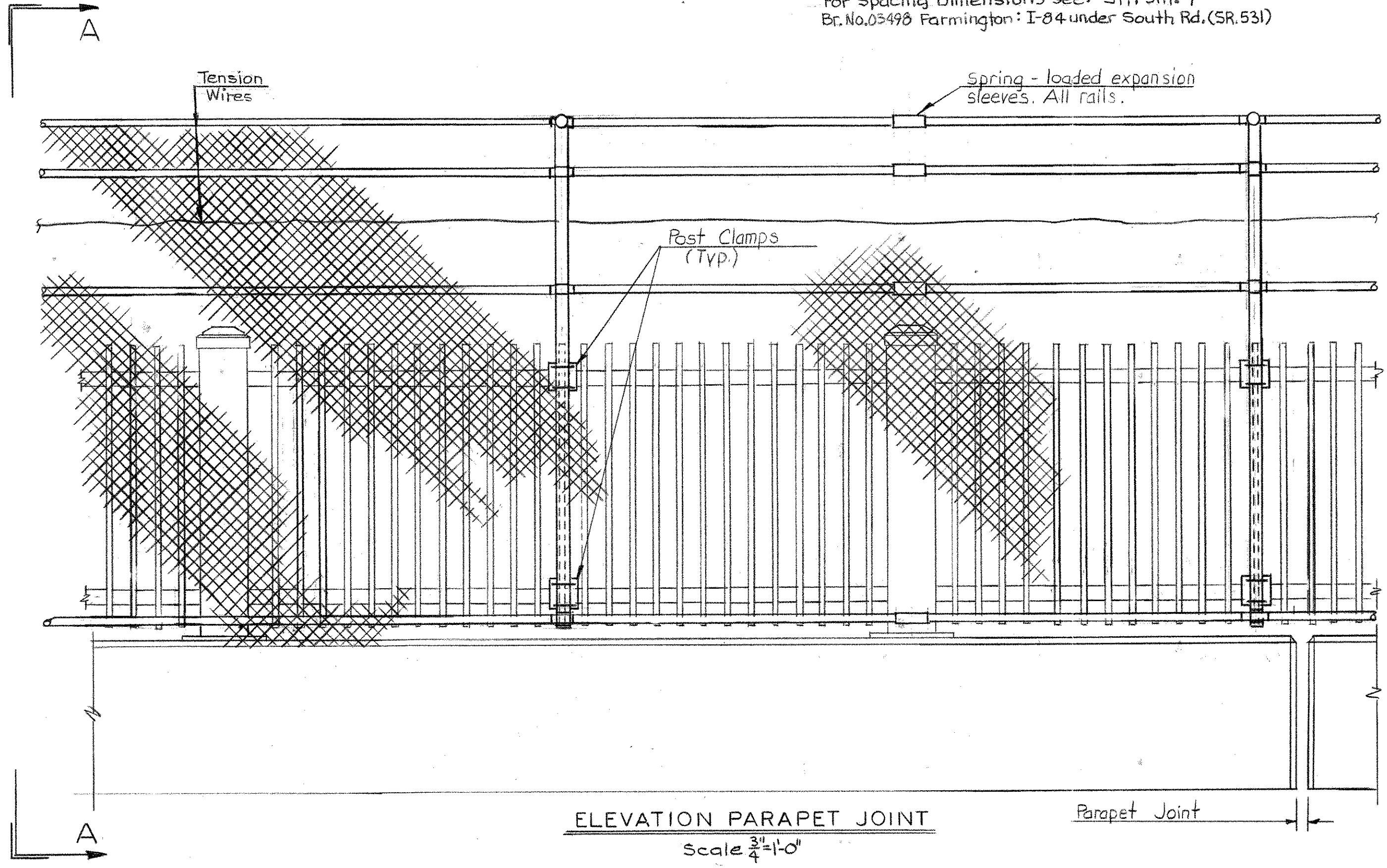

ELEVATION PARAPET JOINT
Scale 3/4"=1'-0"

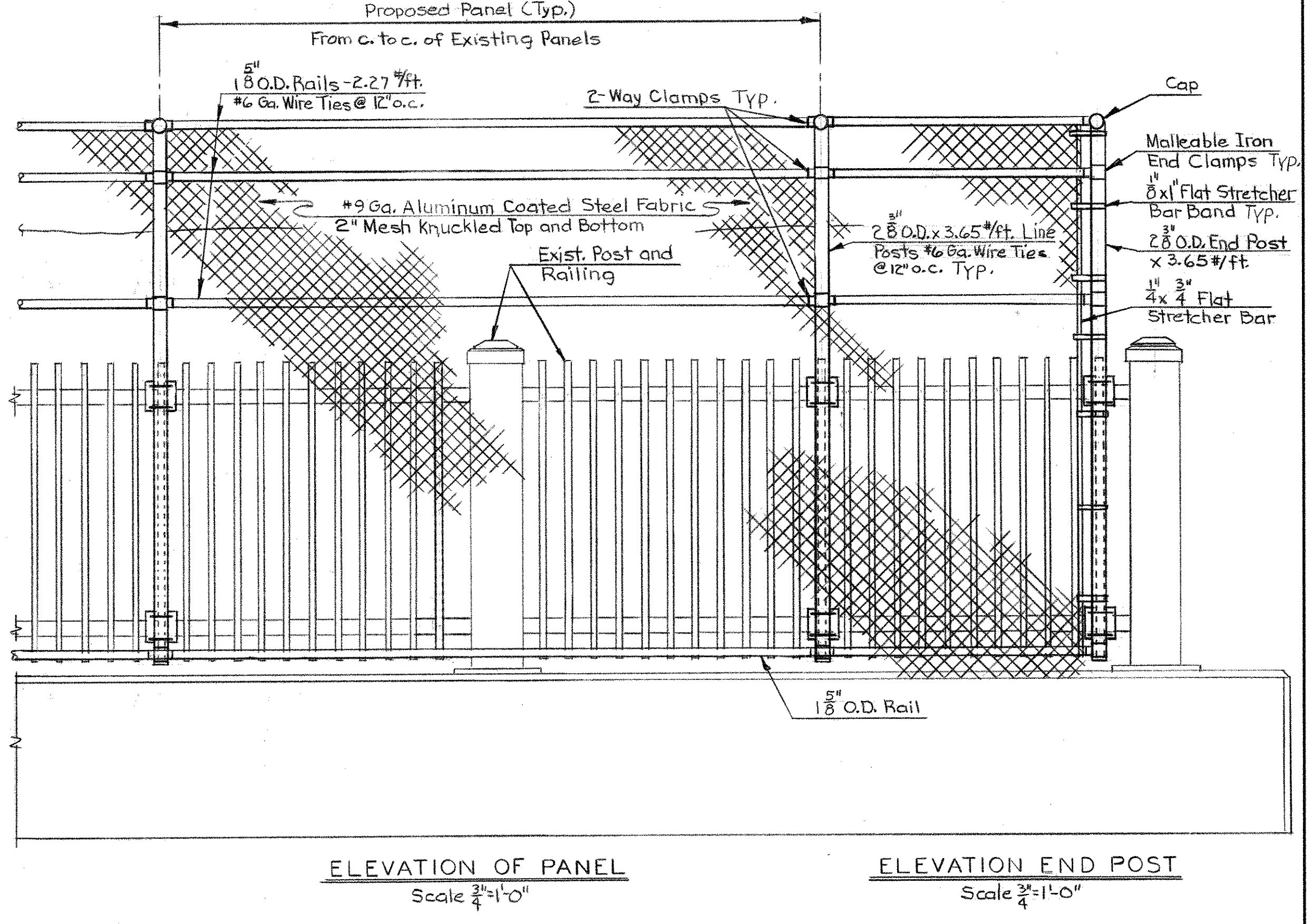

ELEVATION OF PANEL
Scale 3/4"=1'-0"

ELEVATION END POST
Scale 3/4"=1'-0"

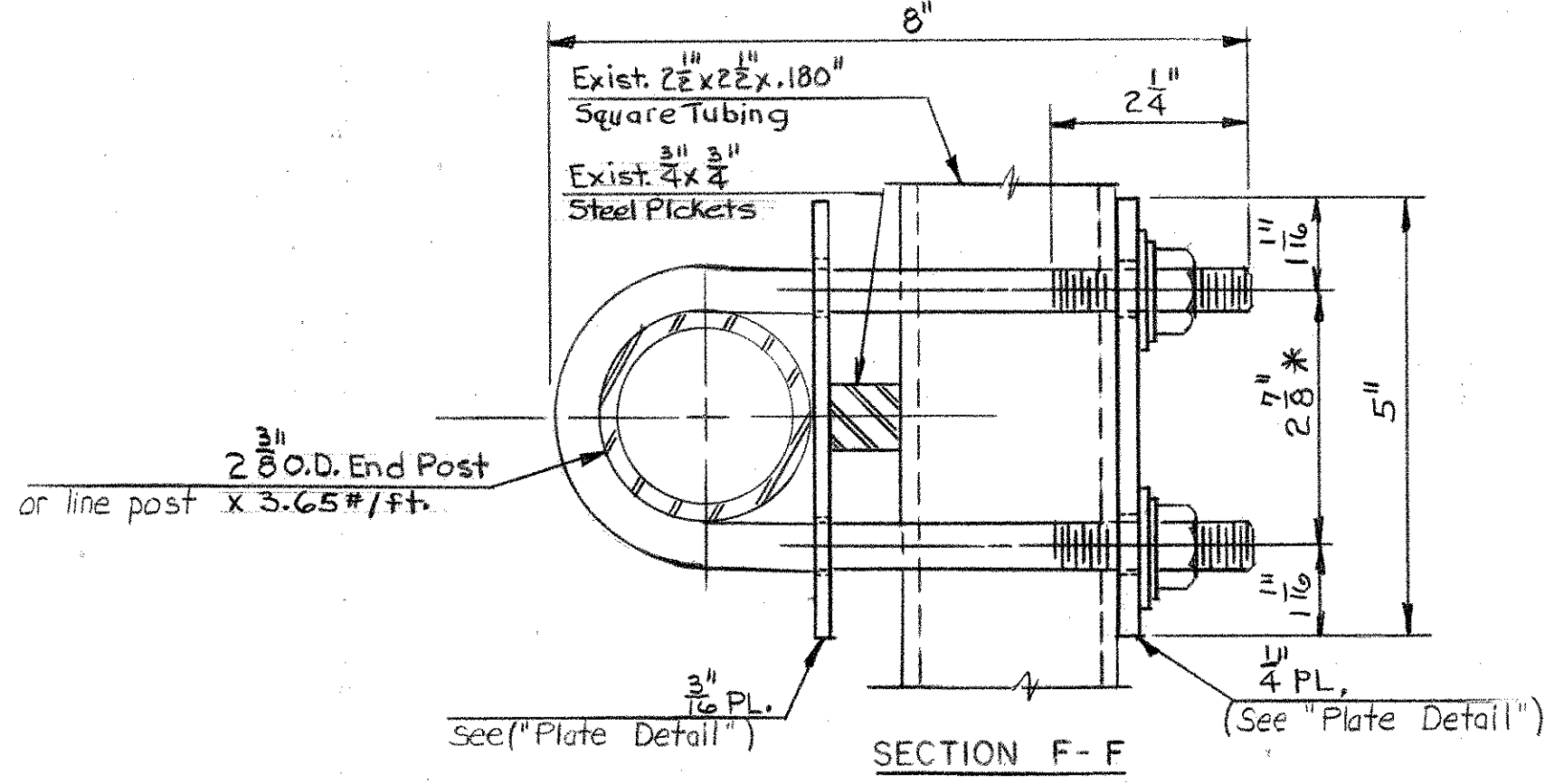

SECTION F-F

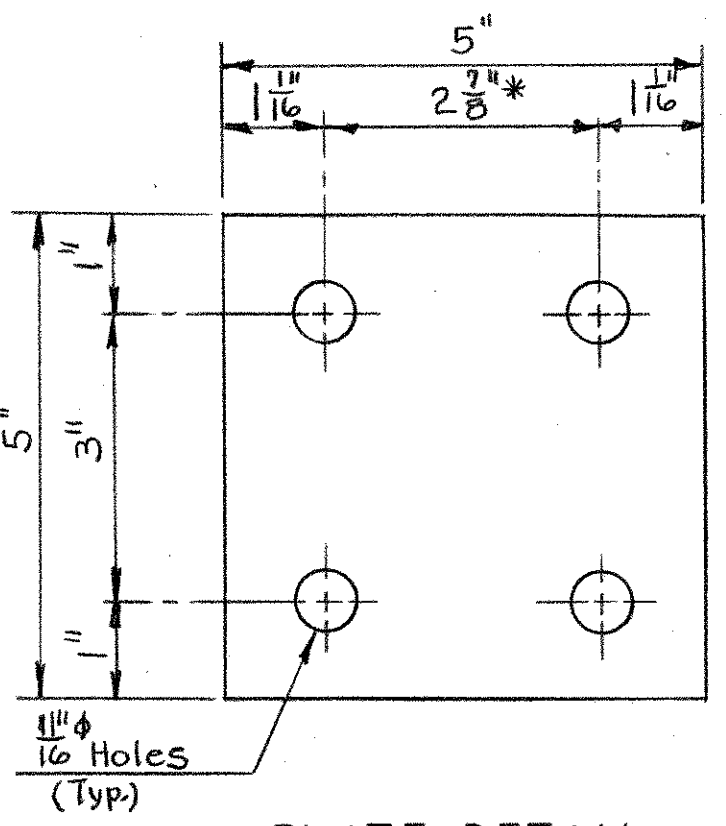
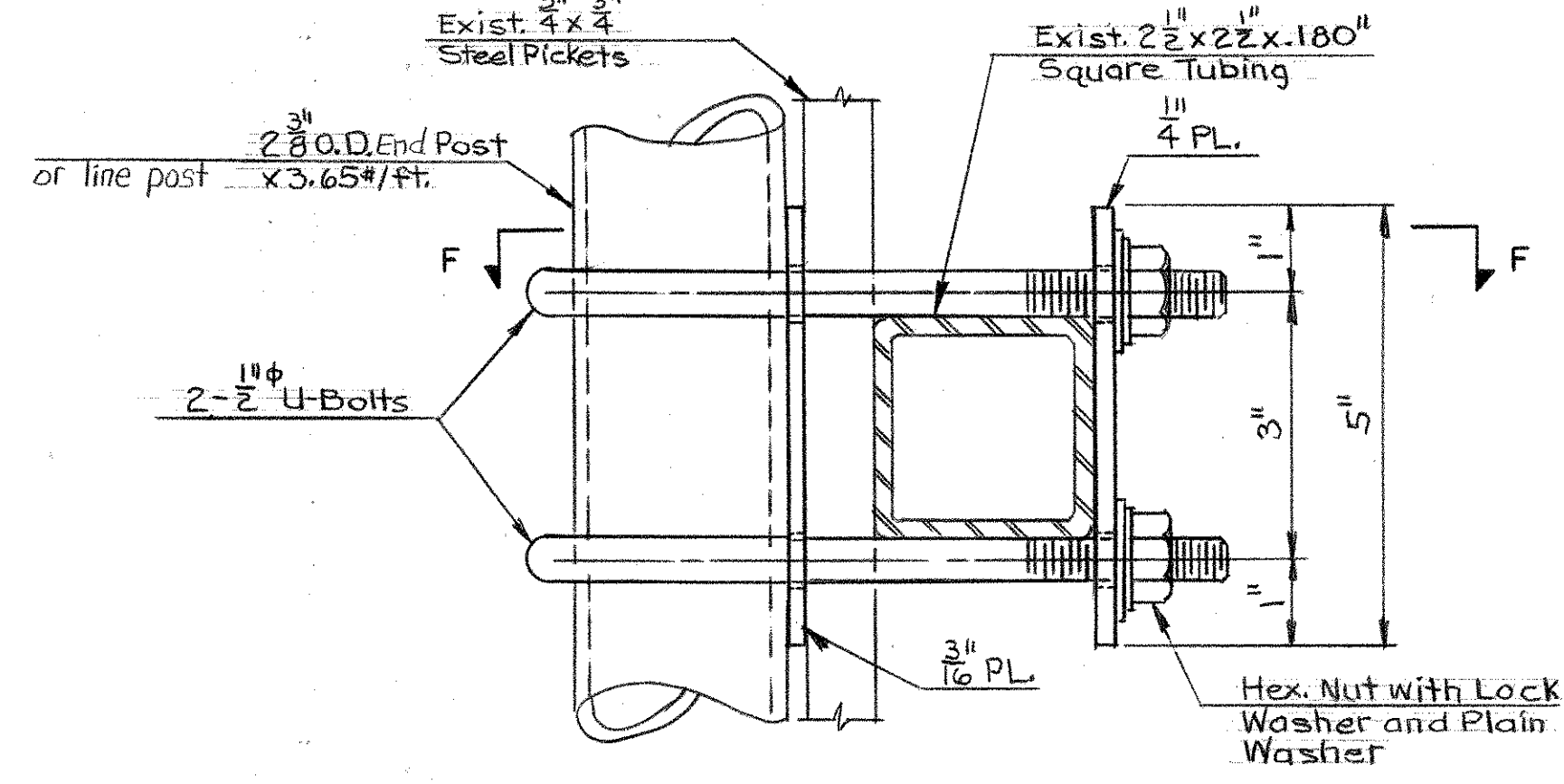

PLATE DETAIL
TYPICAL FOR 3/16" & 1/4" PLATES
Half Scale

NOTE:
For Parapet Joint locations,
See Bridge No. 03498, See
Str. Sht. 1.



DETAIL-A
Half Scale

*Note: U-Bolt must fit snugly over post after galvanizing. The 2 7/8" Dim. may be altered to suit this condition.

CONNECTICUT DEPARTMENT OF TRANSPORTATION		
SOUTHINGTON-WEST HARTFORD		
FARMINGTON I-84 UNDER SOUTH RD. (SR 531) BRIDGE NO. 03498		
PROTECTIVE FENCE (7' HIGH)(CURVED) DETAILS		
ENGINEER Bridge Design Unit		
DESIGNER A.R.F.	DRAFTSMAN F.T.R.	CHECKER J.P.B.
NO. DATE	DESCRIPTION	DATE 3/17/82
REVISIONS		STRUCTURE NO. 131-145

For Spacing Dimension see: Str. Sht. 4
Br.No. 03498 Farmington: I-84 under South Rd. (SR 531)

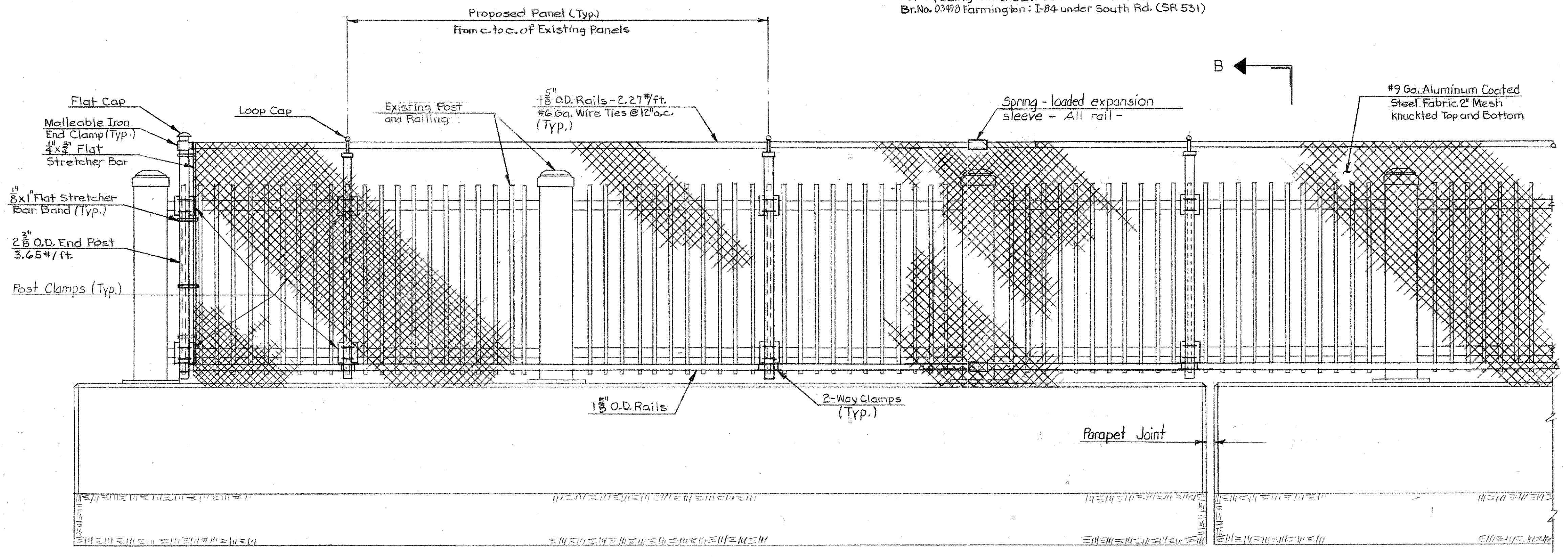

ELEVATION END POST
Scale 3/4" = 1'-0"

ELEVATION OF PANEL
Scale 3/4" = 1'-0"

ELEVATION PARAPET JOINT
Scale 3/4" = 1'-0"

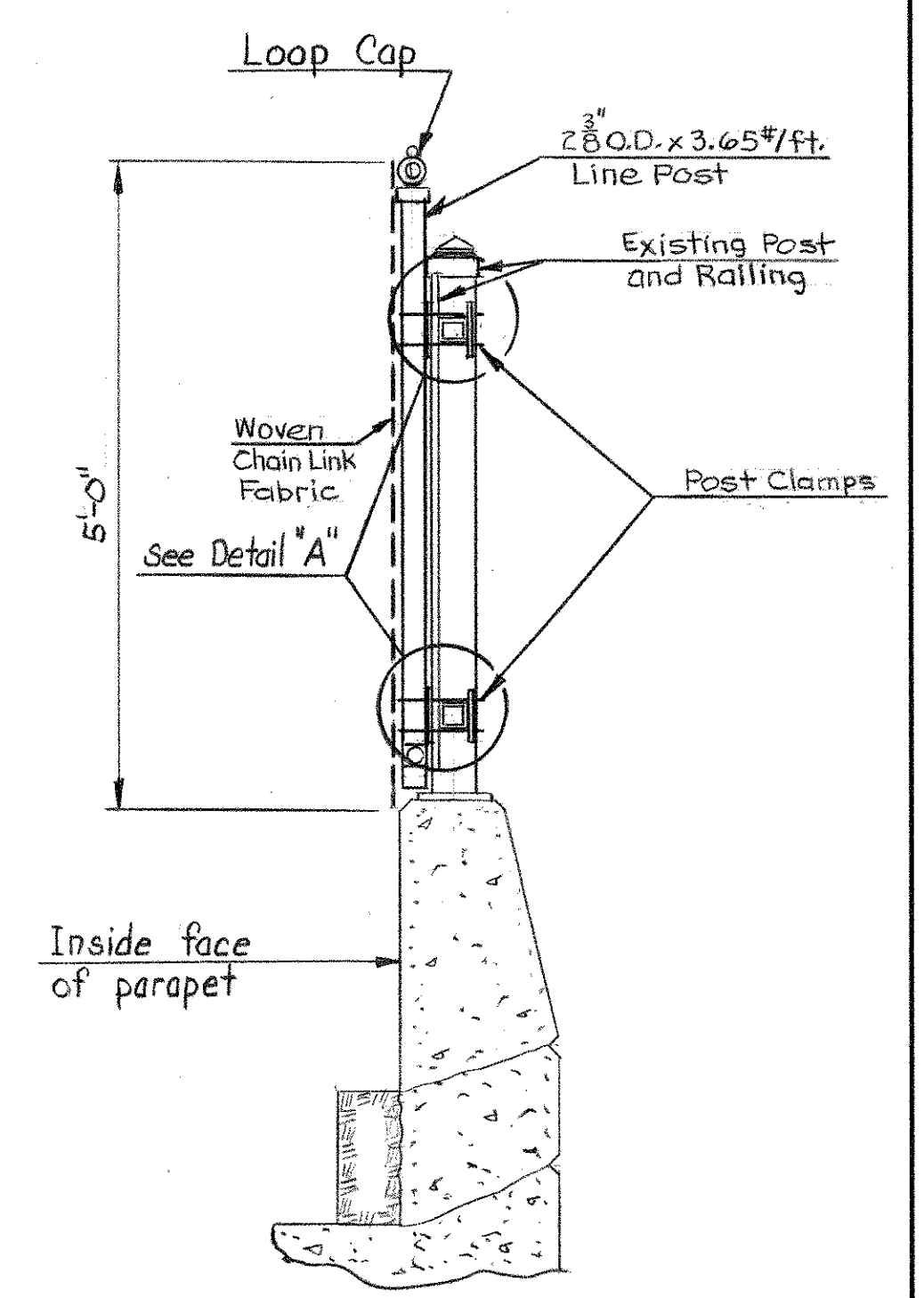

SECTION B-B
Scale 3/4" = 1'-0"

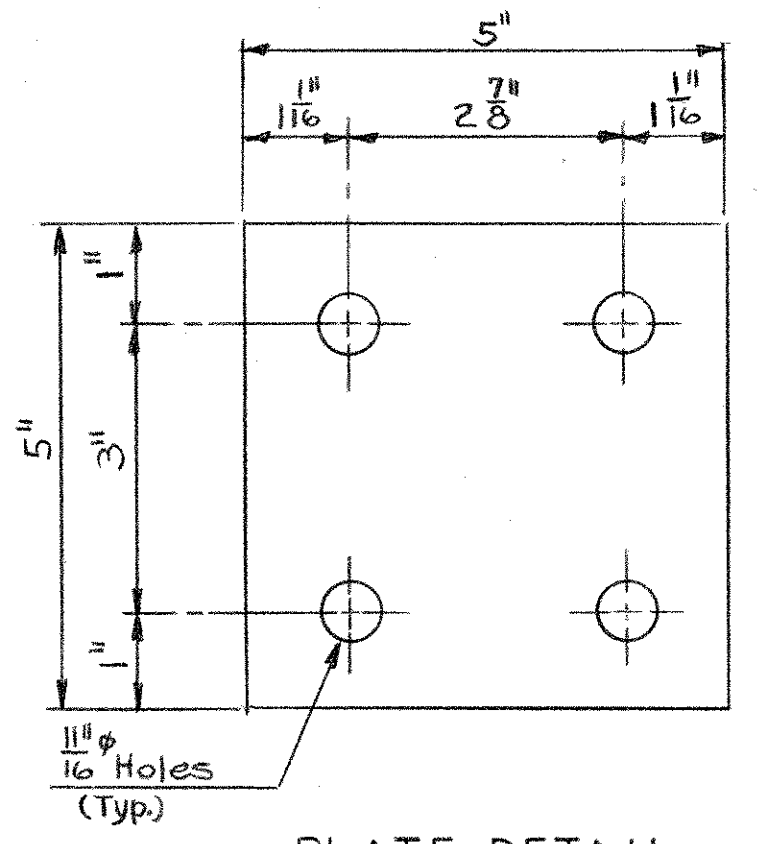
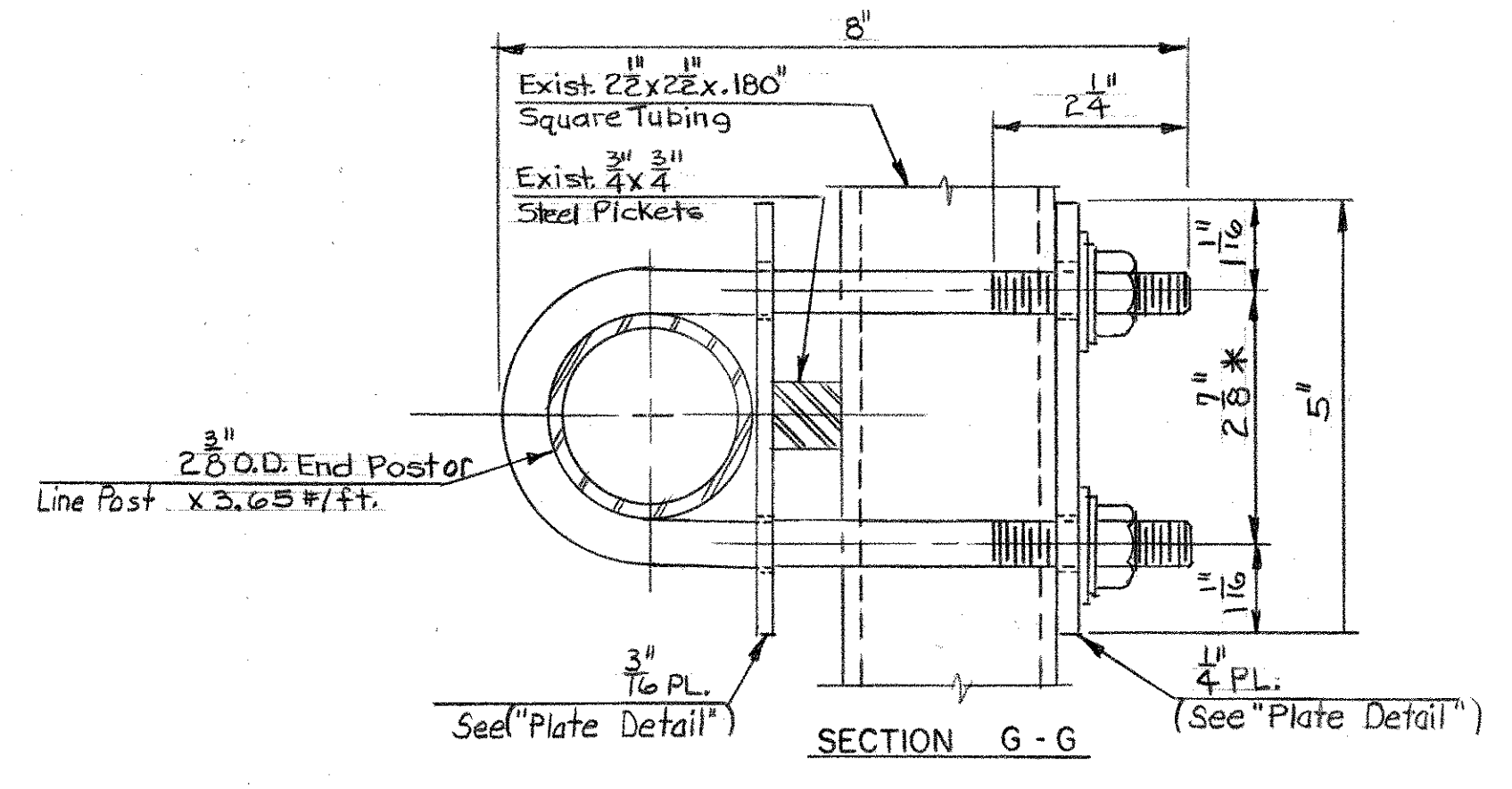

TYPICAL FOR 3/16" & 1/4" PLATES
Half Scale

NOTE:
Parapet Joint Locations, see Br. No. 03498, Str. Sht. 1.

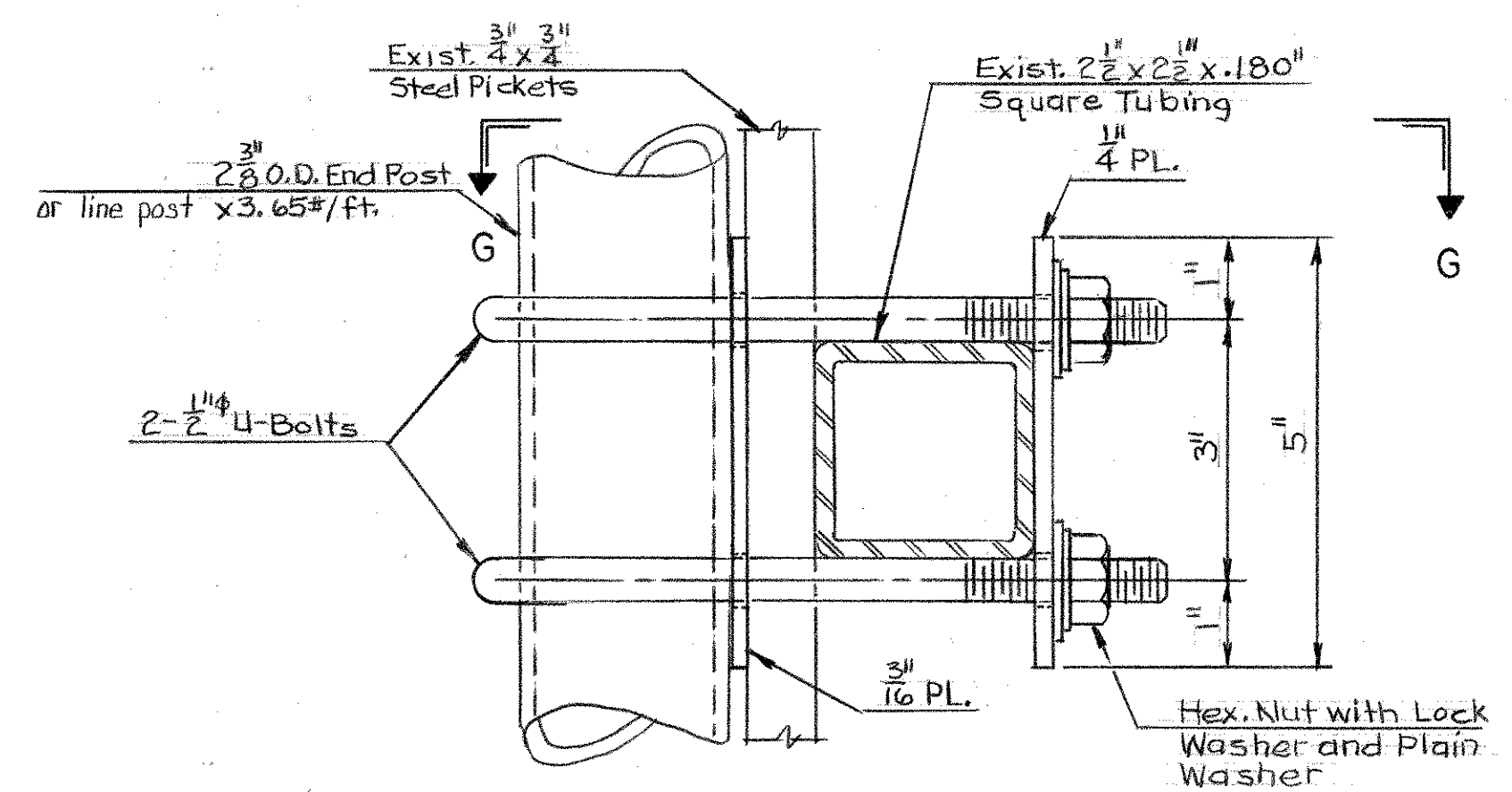

DETAIL-A
Half Scale

*Note: U-Bolt must fit snugly over Post after galvanizing. The 2 7/8" Dim. may be altered to suit this condition.

CONNECTICUT
DEPARTMENT OF TRANSPORTATION
SOUTHINGTON-WEST HARTFORD

FARMINGTON I-84 UNDER
SOUTH RD. (SR.531)
BRIDGE NO. 03498

PROTECTIVE FENCE (5' HIGH) DETAILS

ENGINEER Bridge Design Unit	
DESIGNER A.R.F.	DRAFTSMAN F.T.R.
CHECKER J.R.B.	DATE 3/17/82
NO. DATE	DESCRIPTION
APPROVED <i>[Signature]</i>	DATE 3/17/82
REVISIONS	STRUCTURE NO. 131-145
	BRIDGE LOG NO. 9
	STRUCTURE SHEET NO. 9 OF 9

G20 SERIES			M4 SERIES			W1 SERIES			W4 & W9 SERIES			W6 SERIES			W13 SERIES																	
G20-2 			G20-2a 			M4-10 			W1-IL 			W1-IR 			W1-6 			W9-2 			W6-3 			W13-1 								
SIZE (INCHES)	CONN. D.O.T. #	SUPPORT *	SIZE (INCHES)	CONN. D.O.T. #	SUPPORT *	SIZE (INCHES)	CONN. D.O.T. #	SUPPORT *	SIZE (INCHES)	CONN. D.O.T. #	SUPPORT *	SIZE (INCHES)	CONN. D.O.T. #	SUPPORT *	SIZE (INCHES)	CONN. D.O.T. #	SUPPORT *	SIZE (INCHES)	CONN. D.O.T. #	SUPPORT *	SIZE (INCHES)	CONN. D.O.T. #	SUPPORT *	SIZE (INCHES)	CONN. D.O.T. #	SUPPORT *	SIZE (INCHES)	CONN. D.O.T. #	SUPPORT *			
60 X 24	80-1404	2	48 X 24	80-1412	2	(D) 36 80-3011 1 (E) 48 80-2031 2	(D) 36 80-3010 1 (E) 48 80-2030 2	(D) 36 X 18 80-1410 1 (E) 48 X 24 80-1409 2	(L) (E) 48 80-2010 2 (R) (E) 48 80-2011 2	(E) 48 80-2015 2 (E) 36 X 30 80-2016	(A) 18 X 18 80-3016 1 (B) 24 X 24 80-2022 1	72 X 24 80-1418 2	48 80-2009 2																			
WORK AREA BE PREPARED TO STOP 			NEXT 0 MILES 			M4-8 			W1-2L 			W1-2R 			W1-7 			W4-2 														
SIZE (INCHES)	CONN. D.O.T. #	SUPPORT *	SIZE (INCHES)	CONN. D.O.T. #	SUPPORT *	SIZE (INCHES)	CONN. D.O.T. #	SUPPORT *	SIZE (INCHES)	CONN. D.O.T. #	SUPPORT *	SIZE (INCHES)	CONN. D.O.T. #	SUPPORT *	SIZE (INCHES)	CONN. D.O.T. #	SUPPORT *	SIZE (INCHES)	CONN. D.O.T. #	SUPPORT *	SIZE (INCHES)	CONN. D.O.T. #	SUPPORT *	SIZE (INCHES)	CONN. D.O.T. #	SUPPORT *	SIZE (INCHES)	CONN. D.O.T. #	SUPPORT *	SIZE (INCHES)	CONN. D.O.T. #	SUPPORT *
36 80-3019 1 48 80-2012 2	72 X 14 80-1420	24 X 12 80-1407	(D) 36 80-3013 1 (E) 48 80-2033 2	(D) 36 80-3012 1 (E) 48 80-2032 2	(E) 48 X 24 80-1408 2	(L) (E) 48 80-2028 2 (R) (E) 48 80-2027 2	36 80-3006 1 48 80-2008 2	72 X 24 80-1419 2	48 80-2026 2																							
ROAD CONSTRUCTION NEXT 0 MI. BE PREPARED TO STOP NOTE: THIS SIGN SHALL BE FABRICATED WITH BATTENS 			W1-4L 			W1-4R 			W1-8 																							
CONN. D.O.T. #	SIZE (INCHES)	SUPPORT	SIZE (INCHES)	CONN. D.O.T. #	SUPPORT *	SIZE (INCHES)	CONN. D.O.T. #	SUPPORT *	SIZE (INCHES)	CONN. D.O.T. #	SUPPORT *	SIZE (INCHES)	CONN. D.O.T. #	SUPPORT *	SIZE (INCHES)	CONN. D.O.T. #	SUPPORT *	SIZE (INCHES)	CONN. D.O.T. #	SUPPORT *	SIZE (INCHES)	CONN. D.O.T. #	SUPPORT *	SIZE (INCHES)	CONN. D.O.T. #	SUPPORT *	SIZE (INCHES)	CONN. D.O.T. #	SUPPORT *	SIZE (INCHES)	CONN. D.O.T. #	SUPPORT *
80-1428	120" X 10 8"	BREAKAWAY	(D) 36 80-3022 1 (E) 48 80-2020 2	(D) 36 80-3021 1 (E) 48 80-2019 2	(A) 12 X 18 80-4202 1																											

OVERLAY PANELS

NOTE: PANEL NO'S. SHALL CORRESPOND TO SIZE USED ON SIGNS

2	NUMBER 3 ON OTHER SIDE	2
80-3017		80-2023
5	BLANK ON OTHER SIDE	5
80-3018		80-2024

W20 SERIES			W21 SERIES			W22 SERIES			R11 SERIES																							
W20-1 			W20-7 			W21-1 						W22-1 									R11-2 			R11-3a 			R11-3b 					
SIZE (INCHES)	CONN. D.O.T. #	SUPPORT *	SIZE (INCHES)	CONN. D.O.T. #	SUPPORT *	SIZE (INCHES)	CONN. D.O.T. #	SUPPORT *	SIZE (INCHES)	CONN. D.O.T. #	SUPPORT *	SIZE (INCHES)	CONN. D.O.T. #	SUPPORT *	SIZE (INCHES)	CONN. D.O.T. #	SUPPORT *	SIZE (INCHES)	CONN. D.O.T. #	SUPPORT *	SIZE (INCHES)	CONN. D.O.T. #	SUPPORT *	SIZE (INCHES)	CONN. D.O.T. #	SUPPORT *	SIZE (INCHES)	CONN. D.O.T. #	SUPPORT *	SIZE (INCHES)	CONN. D.O.T. #	SUPPORT *
(D) 36 80-3001 1 (E) 48 80-2005 2	(D) 36 80-3005 1 (E) 48 80-2029 2	(C) 30 80-3015 1 (D) 36 80-3008 1 (E) 48 80-2021 2	36 80-3009 1 48 80-2013 2	(D) 36 80-3020 1 (E) 48 80-2025 2	48 80-2004 2	36 80-3014 1 48 80-2014 2	4 X 6 80-3017 4 X 6 80-3018 5 X 7 80-2023 5 X 7 80-2024	48 X 30 80-0280 2	60 X 30 80-0277 2	60 X 30 80-0278 2																						
W20-2 						W21-2 						W22-3 															R11-4 			E5 SERIES COPY & BORDER-SILVER REFLECT. BACKGROUND-GREEN REFLECT.		
SIZE (INCHES)	CONN. D.O.T. #	SUPPORT *	SIZE (INCHES)	CONN. D.O.T. #	SUPPORT *	SIZE (INCHES)	CONN. D.O.T. #	SUPPORT *	SIZE (INCHES)	CONN. D.O.T. #	SUPPORT *	SIZE (INCHES)	CONN. D.O.T. #	SUPPORT *	SIZE (INCHES)	CONN. D.O.T. #	SUPPORT *	SIZE (INCHES)	CONN. D.O.T. #	SUPPORT *	SIZE (INCHES)	CONN. D.O.T. #	SUPPORT *	SIZE (INCHES)	CONN. D.O.T. #	SUPPORT *	SIZE (INCHES)	CONN. D.O.T. #	SUPPORT *	SIZE (INCHES)	CONN. D.O.T. #	SUPPORT *
(D) 36 80-3002 1 (E) 48 80-2006 2	48 80-2017 2	36 80-3003 1	96 X 18 80-1414	(D) 36 X 30 80-1422 2 (E) 42 X 36 80-1421 2	60 X 66 80-1426 2-4 Lb. 60 X 66 80-1427 2-4 Lb.	8 X 30 80-6102	48 X 30 80-0282 2	60 X 30 80-0281 2																								
W20-4 						W21-6 			W22-2 			NOTES: * SUPPORTS NOTED ARE FOR LONG TERM INSTALLATION (SEE STD. SHEET "TYPICAL SIGN POSTS & SIGN MOUNTING DETAILS FOR SIGN FACE SHEET ALUMINUM") - FOR TEMPORARY SUPPORTS SEE STD. SHEET "TYPICAL CONSTRUCTION SIGN SUPPORTS AND CHANNELIZING DEVICES". FOR SPECIFIC LEGEND & SIGN DESIGN, REFER TO CONN. D.O.T. DETAILED DRAWINGS. FOR BOLT HOLE PATTERN REFER TO F.H.W.A. PUBLICATION "STANDARD HIGHWAY SIGNS AS SPECIFIED IN THE M.U.T.C.D. 1978". SIGNS OF DIFFERENT DIMENSIONS TO BE ERECTED ON THE SAME SUPPORTS MAY REQUIRE SPECIAL BOLT HOLE PATTERNS. WHERE (0-00) SHOWN ON SIGN-INDICATES VARIABLE NUMBER(S) LEGEND. COLORS OF SIGNS (UNLESS OTHERWISE SPECIFIED) LEGEND- BLACK PLAIN BACKGROUND-ORANGE REFLECTORIZED. COLOR & MATERIALS SHALL CONFORM TO STATE SPECIFICATIONS. MATERIALS: ALUMINUM THICKNESS FOR ALL SIGNS SHALL BE 100 EXCEPT SIGNS NOS. 80-1415, 80-1426, 80-1427, 80-1428 & E5-1 WHICH SHALL BE 125. PLYWOOD THICKNESS 1/2" EXTERIOR GRADE A-C OR BETTER, SIGN BLANKS SHALL HAVE ONE COAT OF PRIMER PAINT PRIOR TO APPLICATION OF REFLECTORIZATION AND COPY. ON R1-SERIES SIGN THE LEGEND "S.T.C." SHALL APPEAR.			R1-SERIES R1-1 BACKGROUND RED LEGEND SILVER 			E5-1 														
SIZE (INCHES)	CONN. D.O.T. #	SUPPORT *	SIZE (INCHES)	CONN. D.O.T. #	SUPPORT *	SIZE (INCHES)	CONN. D.O.T. #	SUPPORT *	SIZE (INCHES)	CONN. D.O.T. #	SUPPORT *	SIZE (INCHES)	CONN. D.O.T. #	SUPPORT *	SIZE (INCHES)	CONN. D.O.T. #	SUPPORT *	SIZE (INCHES)	CONN. D.O.T. #	SUPPORT *	SIZE (INCHES)	CONN. D.O.T. #	SUPPORT *	SIZE (INCHES)	CONN. D.O.T. #	SUPPORT *	SIZE (INCHES)	CONN. D.O.T. #	SUPPORT *	SIZE (INCHES)	CONN. D.O.T. #	SUPPORT *
(D) 36 80-3004 1 (E) 48 80-2007 2	96 X 4 8 80-1415	36 80-3007 1	(D) 36 X 30 80-1424 2 (E) 42 X 36 80-1423 2																													
W20-5 																																
SIZE (INCHES)	CONN. D.O.T. #	SUPPORT *	SIZE (INCHES)	CONN. D.O.T. #	SUPPORT *	SIZE (INCHES)	CONN. D.O.T. #	SUPPORT *	SIZE (INCHES)	CONN. D.O.T. #	SUPPORT *	SIZE (INCHES)	CONN. D.O.T. #	SUPPORT *	SIZE (INCHES)	CONN. D.O.T. #	SUPPORT *	SIZE (INCHES)	CONN. D.O.T. #	SUPPORT *	SIZE (INCHES)	CONN. D.O.T. #	SUPPORT *	SIZE (INCHES)	CONN. D.O.T. #	SUPPORT *	SIZE (INCHES)	CONN. D.O.T. #	SUPPORT *	SIZE (INCHES)	CONN. D.O.T. #	SUPPORT *
(L) 48 80-2002 2 (R) 48 80-2003 2	(L) 48 80-2034 2 (R) 48 80-2035 2																															

CONNECTICUT DEPARTMENT OF TRANSPORTATION BUREAU OF HIGHWAYS DIVISION OF TRAFFIC

SIGNS FOR MAINTENANCE, CONSTRUCTION AND PERMIT OPERATIONS

SUBMITTED BY: [Signature] DATE: [Date]
 SUBMITTED BY: [Signature] DATE: 11/10/81
 APPROVED: [Signature] DATE: [Date]
 CHIEF OF TRAFFIC ENGINEERING

SCALE: NONE 23

INITIAL DATE
 M.W.C. 4-22-76
 F.C.L.G. 6-24-76
 DRAWN BY: [Signature]
 CHECKED BY: [Signature]

REVISIONS		
NO.	DATE	DESCRIPTION

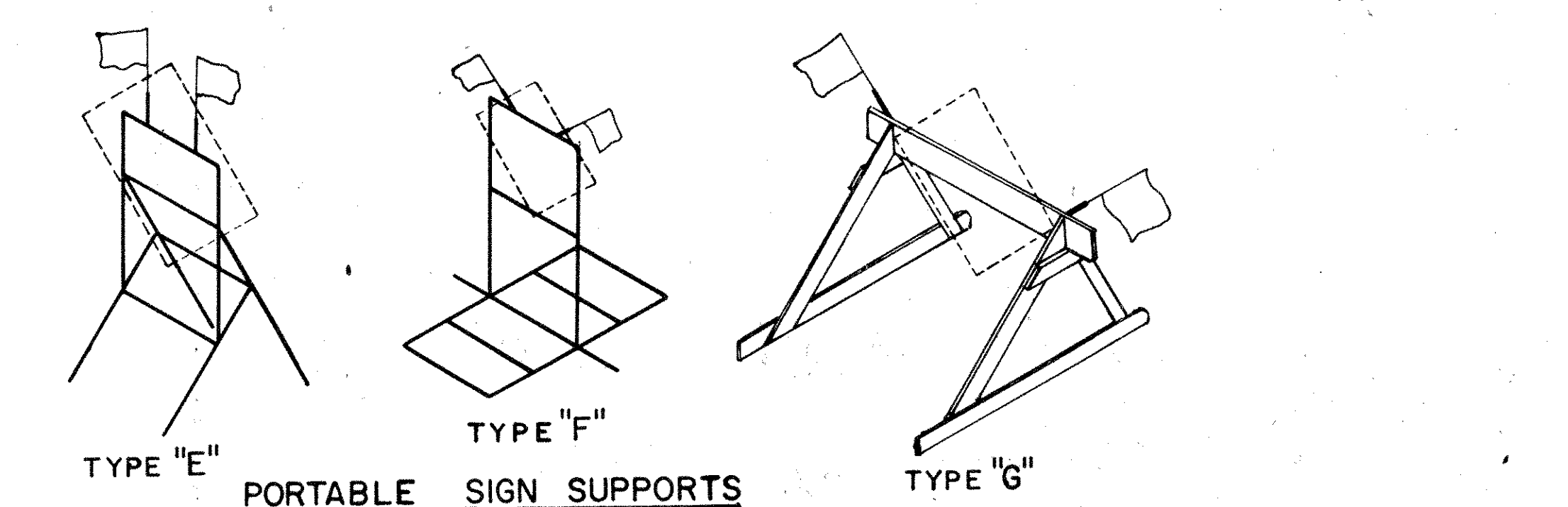
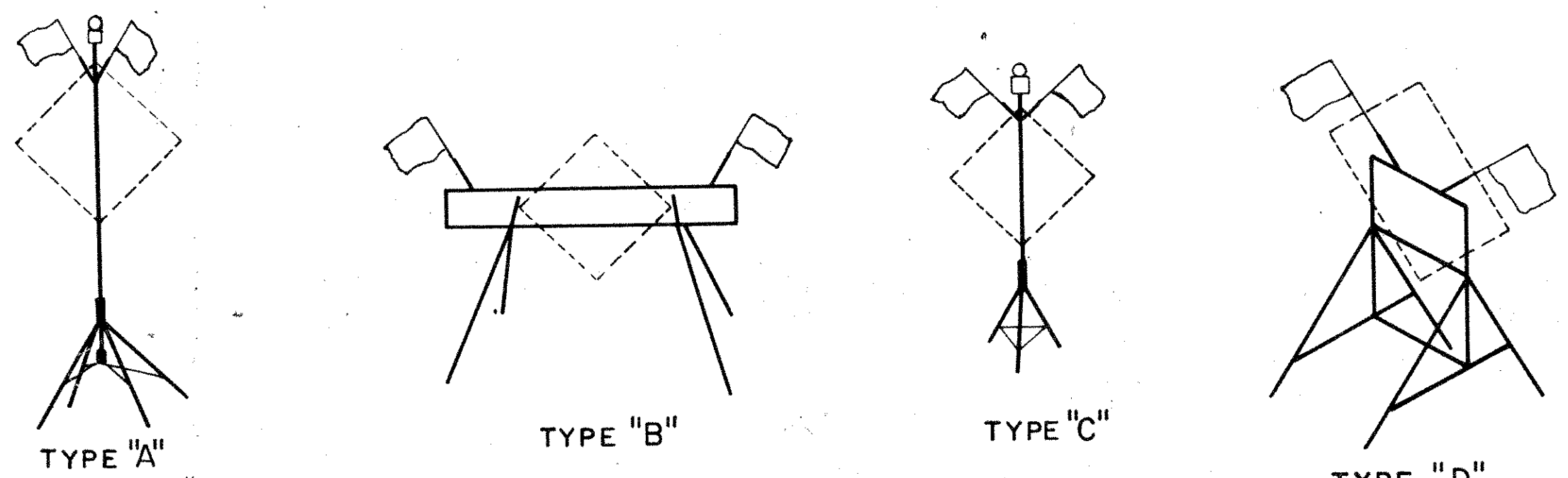

PORTABLE SIGN SUPPORTS

NOTES:

- Sign supports shall be constructed of a suitable material. Break-away and/or collapsible features shall be incorporated in the design so that the support will not constitute a hazard to the motorist and/or workmen in the work area.
- Mounting height of sign utilizing structures depicted above shall be a minimum of 12', with a recommended height of 18' above pavement.
- The Engineer reserves the right to reject any support which he deems a hazard, or not in the best interest of the motoring public.
- Flags and/or barricade warning lights shall be used as shown on the Traffic Control Plans and as directed by the Engineer.

5. Design details of Type "G" are available at the D.O.T. Bureau of Highways-Traffic Division.

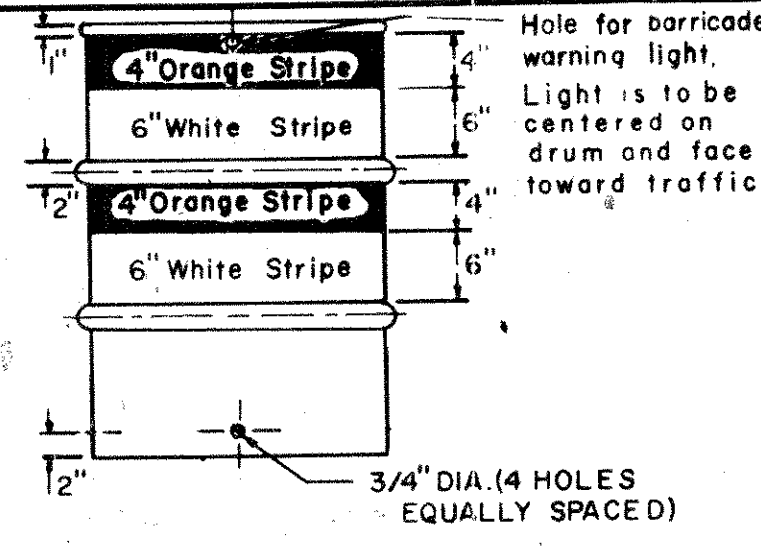

TRAFFIC DRUM

NOTES:

- Traffic drum shall be designed in accordance with the specifications.
- The Engineer reserves the right to reject any drum he deems not suitable for purpose intended.
- The entire area of orange and white stripes shall be Reflective Sheeting-Encapsulated Lens.
- ReflectORIZED stripes should not be placed over the protruding circumferential ribs of the drum.
- The sections of drums not covered with reflectORIZED stripes shall be painted orange.

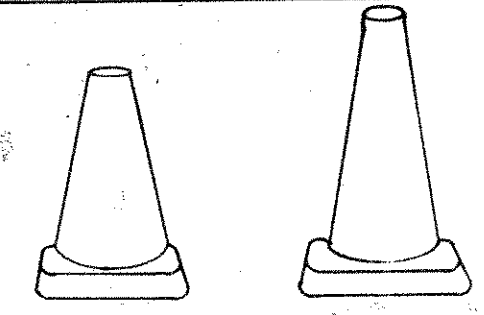

TRAFFIC CONES

NOTES:

- Traffic cones shall be designed in accordance with the Manual on Uniform Traffic Control Devices, Chapter VII, Section 6C-3, Cone Design.
- Height of cones shall be 18" or 28" as specified.
- Cones shall be predominately federal orange in color.
- Rubber cones shall be reflectORIZED with interior ribs for rigidity.
- Plastic cones shall be color impregnated.
- Cones shall be of a thickness necessary to withstand impact without damage to either cone or impacting vehicle.
- The Engineer reserves the right to reject any cone he deems not suitable for purpose intended.

SERIES 16 SIGNS

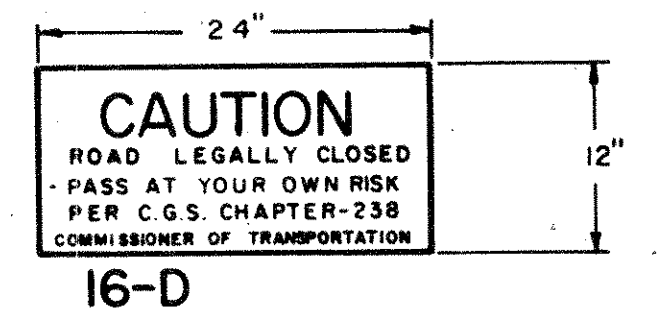
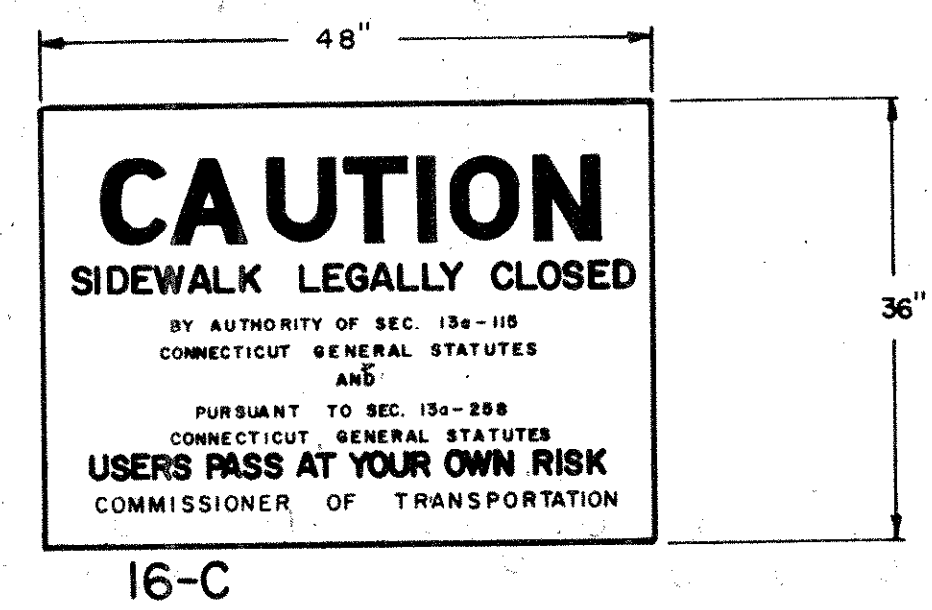
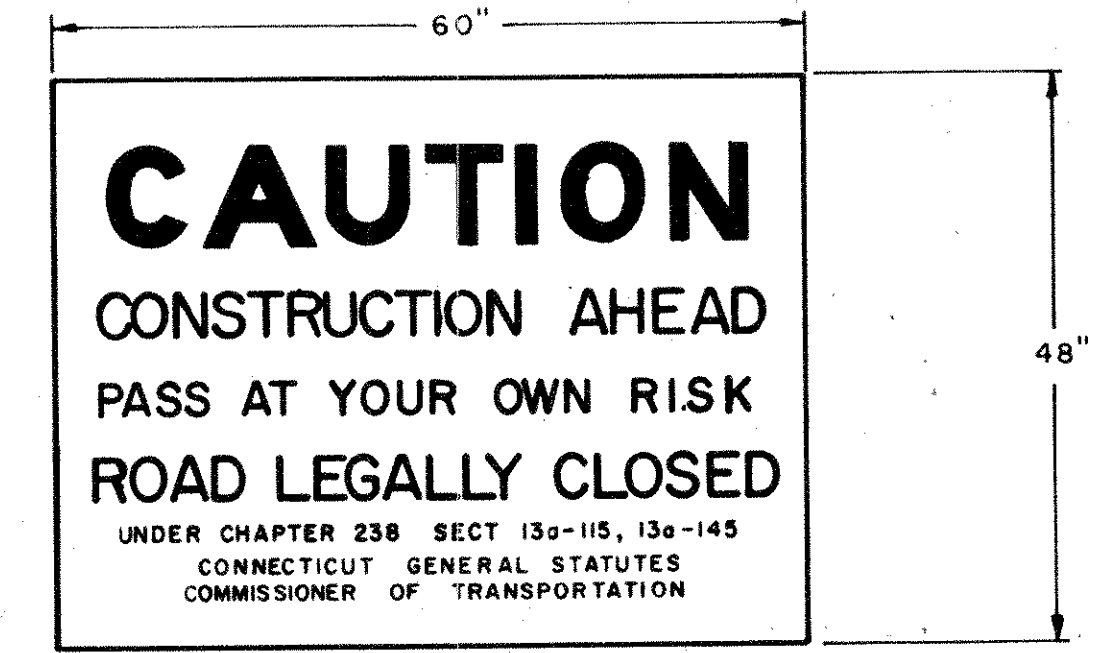
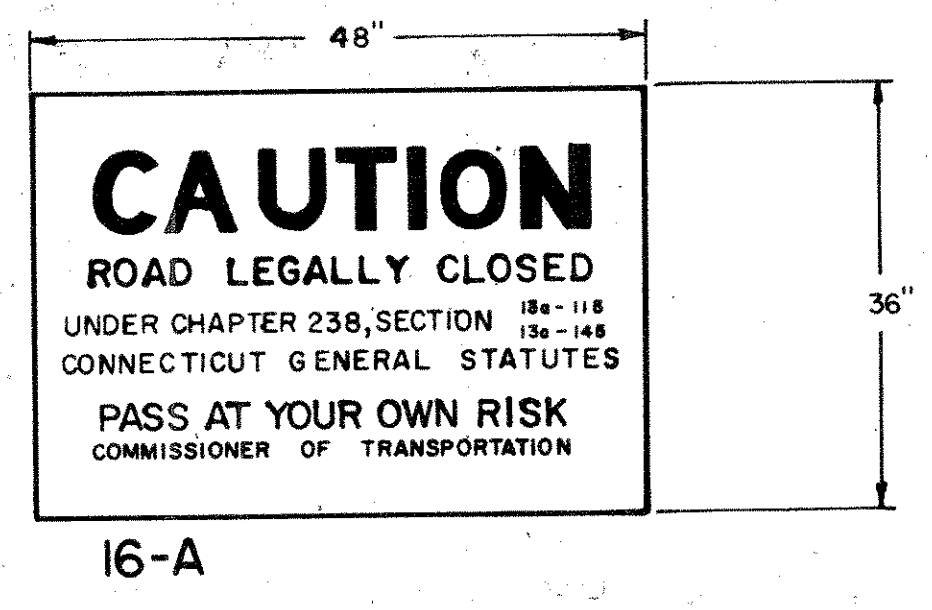

16A, 16B AND 16C SIGNS ARE TO BE ERECTED ON TWO SIGN POSTS UNLESS DIRECTED OTHERWISE BY THE ENGINEER

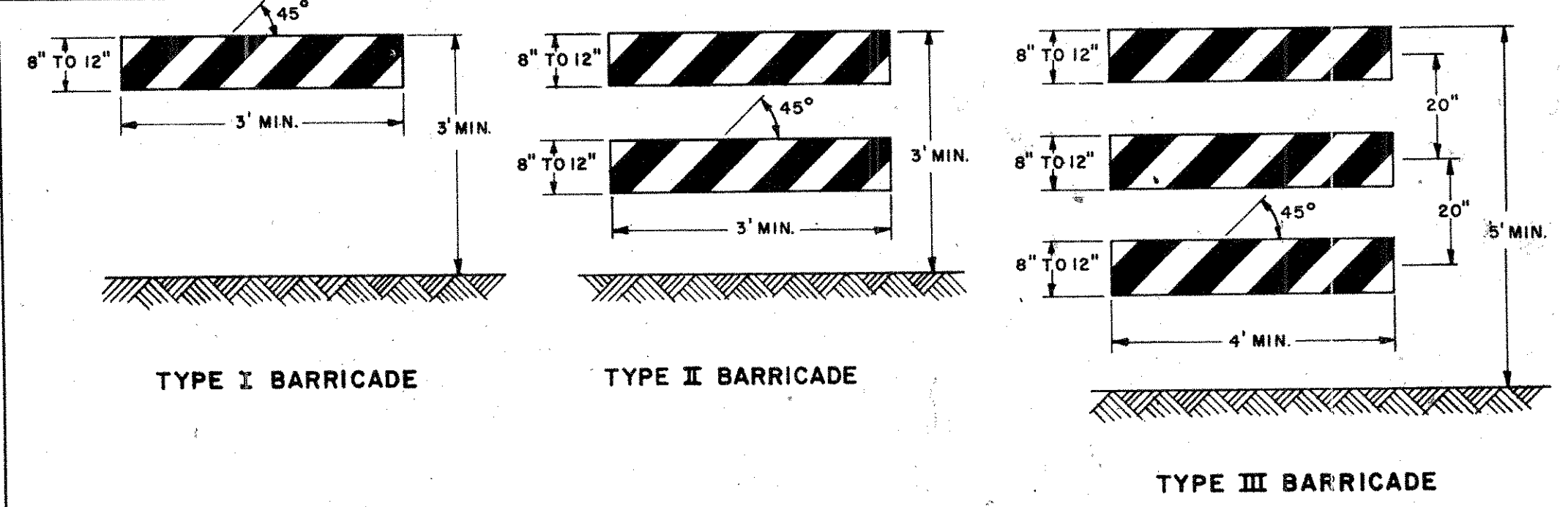

CONSTRUCTION BARRICADES

NOTES:

- MARKINGS FOR BARRICADE RAILS SHALL BE ALTERNATE ORANGE AND WHITE STRIPES SLOPING DOWNWARD IN THE DIRECTION TRAFFIC IS TO PASS. 6" WIDE STRIPES SHALL BE USED
- THE ENTIRE AREA OF ORANGE AND WHITE STRIPES SHALL BE REFLECTIVE SHEETING-ENCAPSULATED LENS. RAILS FOR TYPE I AND TYPE II BARRICADES SHALL BE REFLECTORIZED ON BOTH SIDES, WHERE TRAFFIC PASSES ONLY IN ONE DIRECTION OF TRAVEL, ONLY THE SIDE FACING TRAFFIC SHALL BE REFLECTORIZED.
- THE ENGINEER RESERVES THE RIGHT TO REJECT ANY BARRICADE WHICH HE DEEMS A HAZARD, OR NOT IN THE BEST INTEREST OF THE MOTORING PUBLIC.
- CORNERS OF ALUMINUM BARRICADE RAILS SHALL BE ROUNDED.

PLACEMENT OF ROADSIDE SIGNS

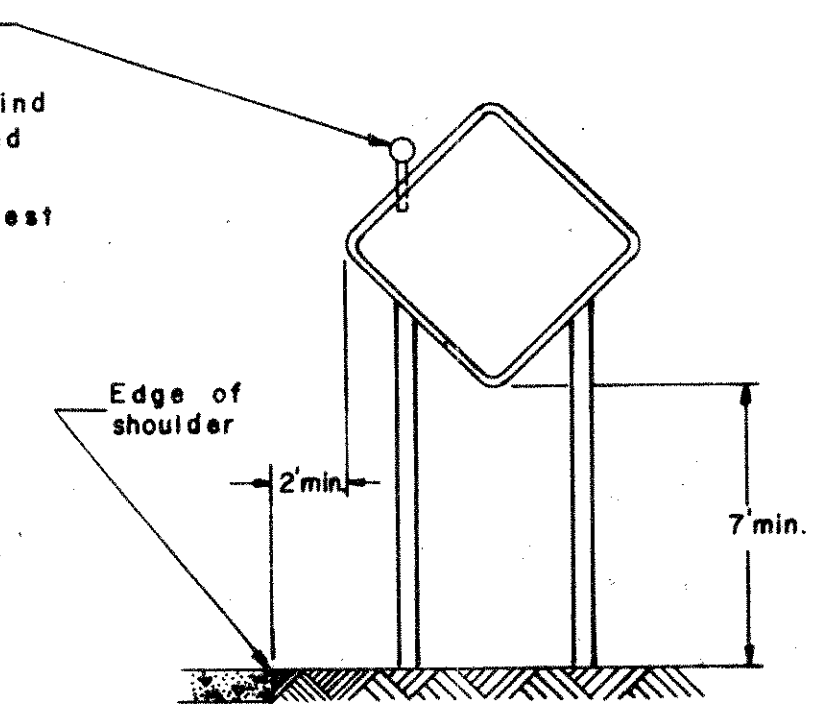
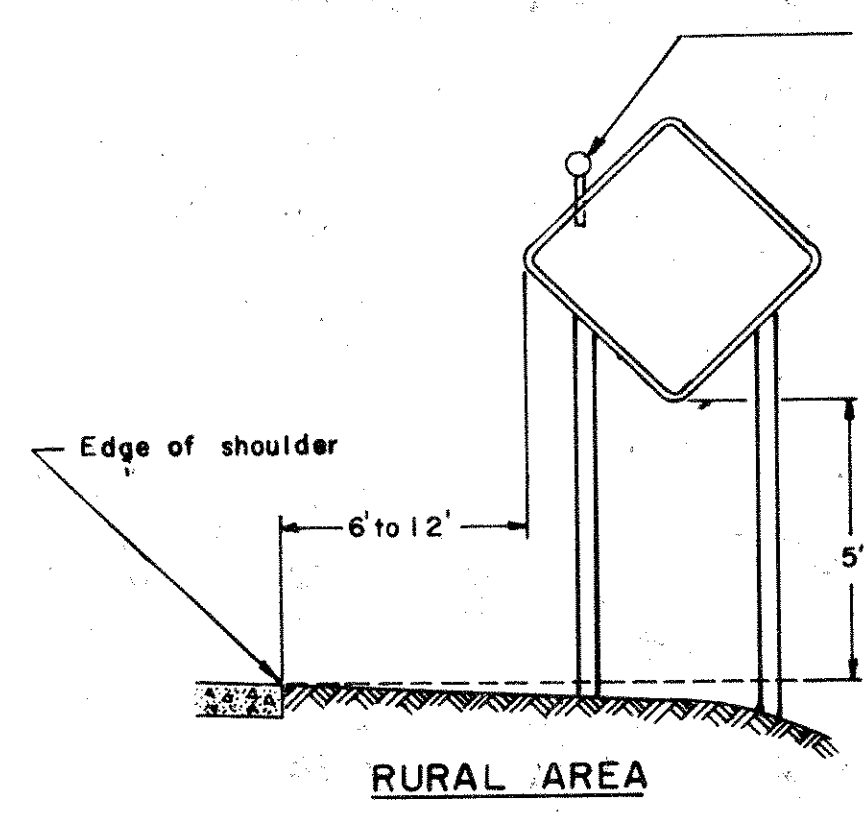

TYPICAL LONG TERM INSTALLATION

NOTE: Supports shall be metal sign post, see typical sheets: Typical Sign Support and Sign Placement Details. Typical Metal Sign Posts for Sign Face Sheet Aluminum.

REVISIONS		
NO.	DATE	DESCRIPTION
1	5-81	REV. BARR. SUPPORT TO 3" OR 4" PLAS. & ADD ROPE

CONNECTICUT DEPARTMENT OF TRANSPORTATION
BUREAU OF HIGHWAYS
DIVISION OF TRAFFIC

TYPICAL CONSTRUCTION SIGN SUPPORTS AND CHANNELIZING DEVICES

SUBMITTED BY: *[Signature]* DATE: 5-18-81
 SUBMITTED BY: *[Signature]* DATE: 5-19-81
 APPROVED: *[Signature]* DATE: 5-22-81
 CHIEF OF TRAFFIC ENGINEERING

SCALE: NONE

TYPICAL 3" OR 4" PLASTIC SIGN/BARRICADE SUPPORT

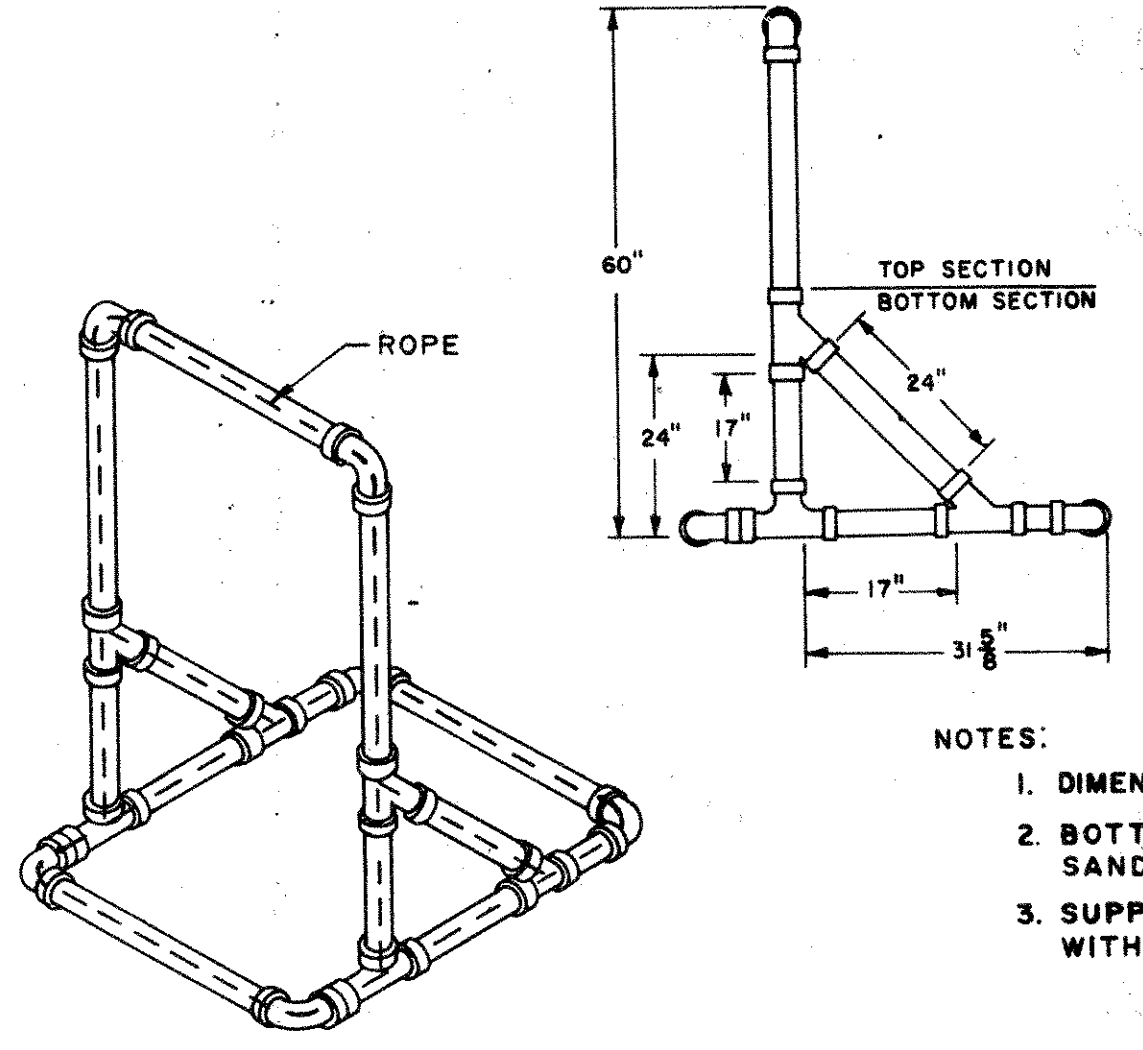

NOTES:

- DIMENSIONS ARE APPROXIMATE
- BOTTOM SECTION MAY BE FILLED WITH SAND FOR BALLAST.
- SUPPORT SHALL BE LOOSELY THREADED WITH ROPE, KNOTTED AS REQUIRED.

NOTES:

The steel posts shall be square tubes formed of 12 gage (.105 U.S.S Gage) cold rolled carbon steel conforming to ASTM-A366. They shall be hot dip galvanized to provide a zinc coating of 1.25 oz. in conformance with ASTM-A525. Wall thickness tolerance shall not exceed +.011, -.008 inch.

Tubing shall be corner welded by high-frequency resistance welding, or approved equal, and externally scarfed to agree with corner radii. Consecutive size tubes shall telescope freely for a minimum of 10'. Tolerance on hole size shall not exceed $\frac{1}{64}$ ". Tolerance on hole spacing shall not exceed $\frac{1}{8}$ " in 20'.

Installation: Sign post anchor can be driven through blacktop surfaces without first opening a hole. However, in concrete surfaces a hole must be made prior to driving anchor. Driving caps must be used.

- Step 1- Drive sign post anchor to within three or four inches of surface.
- Step 2- Drive anchor sleeve until top is flush with top of sign post anchor and holes match, then drive both sign post anchor and anchor sleeve until one hole is exposed above ground surface for bolt connection. Exposed length not to exceed 1".
- Step 3- Insert sign post and bolt in place.

Single post installation for signs with total area not exceeding 2 1/2 square feet
Two post installation for signs with total area over 2 1/2 square feet but not to exceed 5 square feet

Connecting bolt shall be installed perpendicular to the direction of traffic.
Utilization of square tubular sign support hardware and appurtenances, not shown on this plan, shall be subject to submission and approval of "Catalog Cuts".

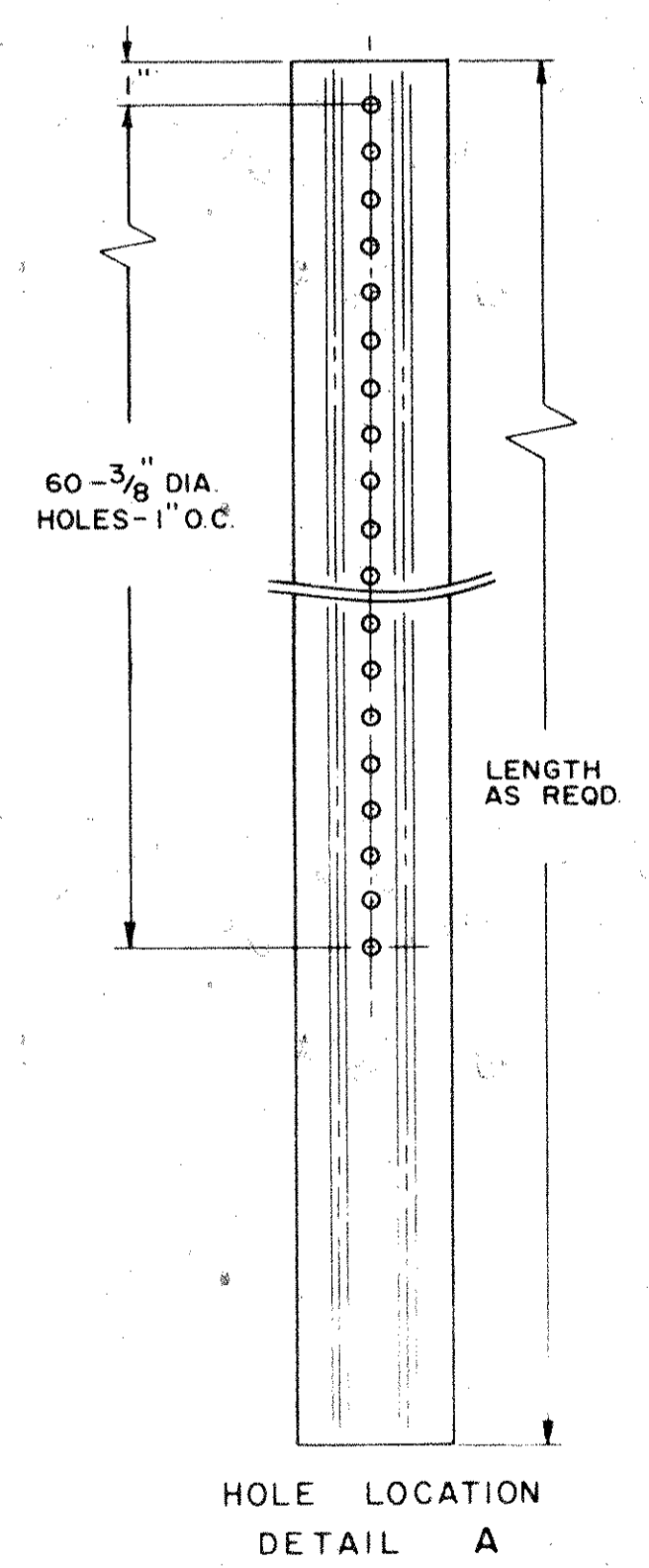
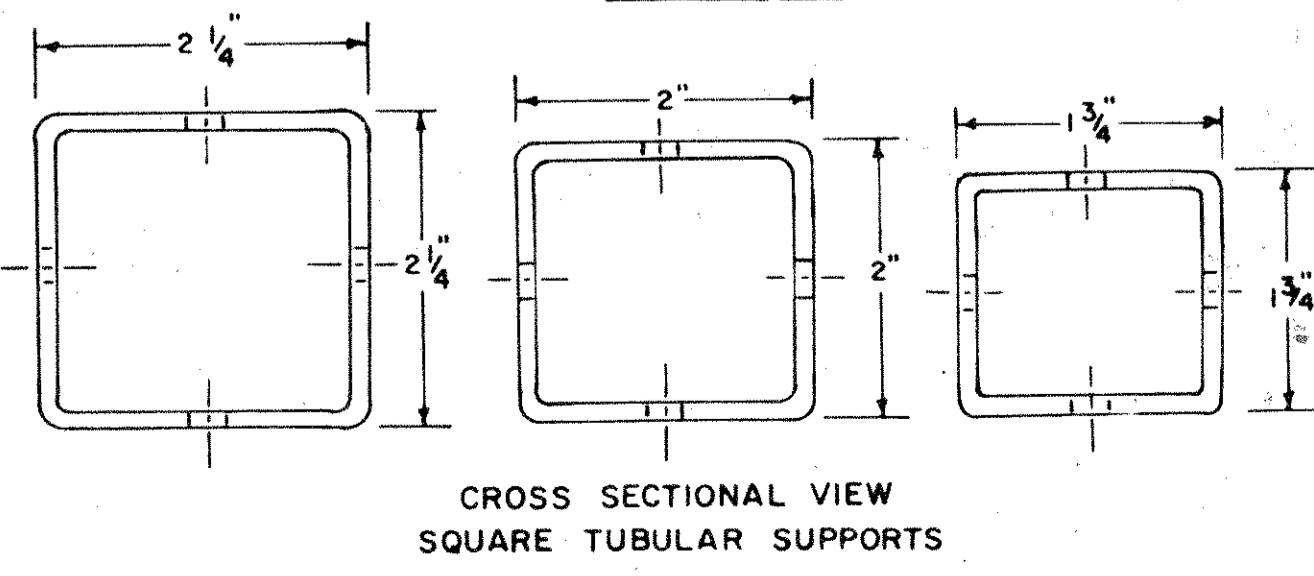
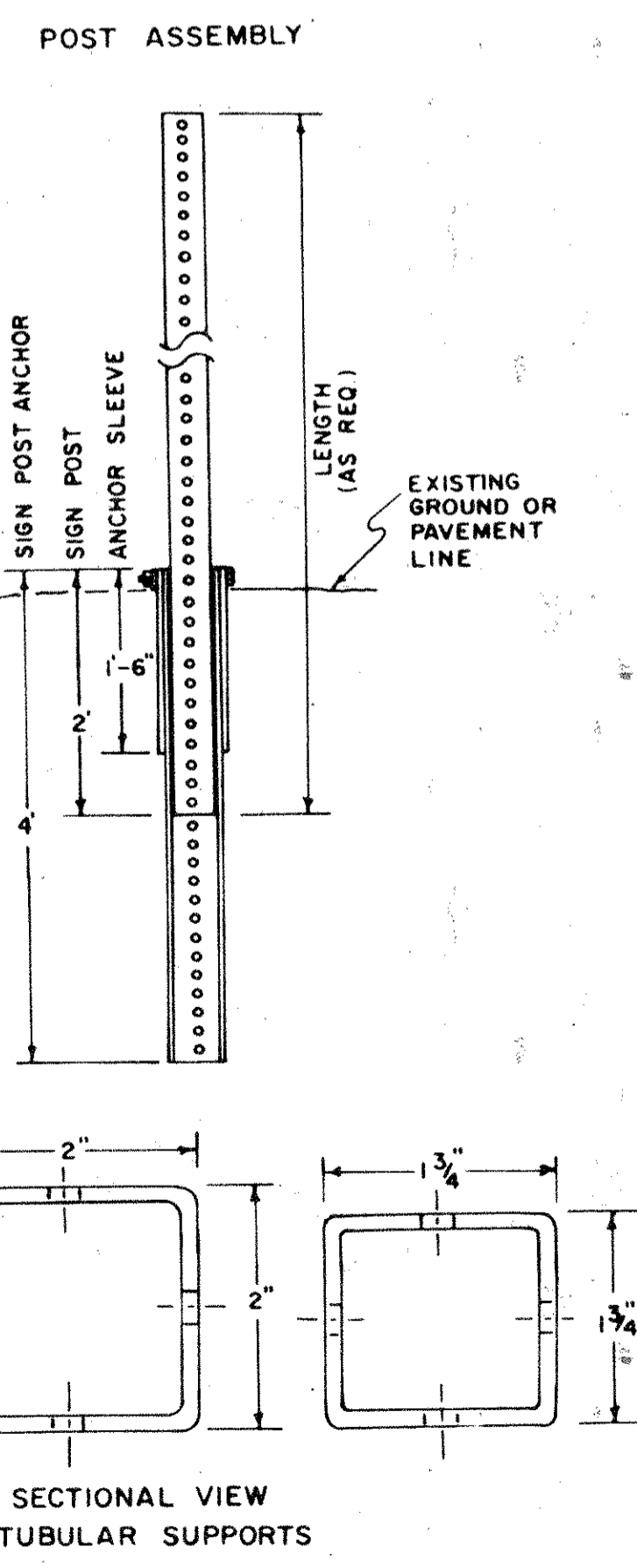
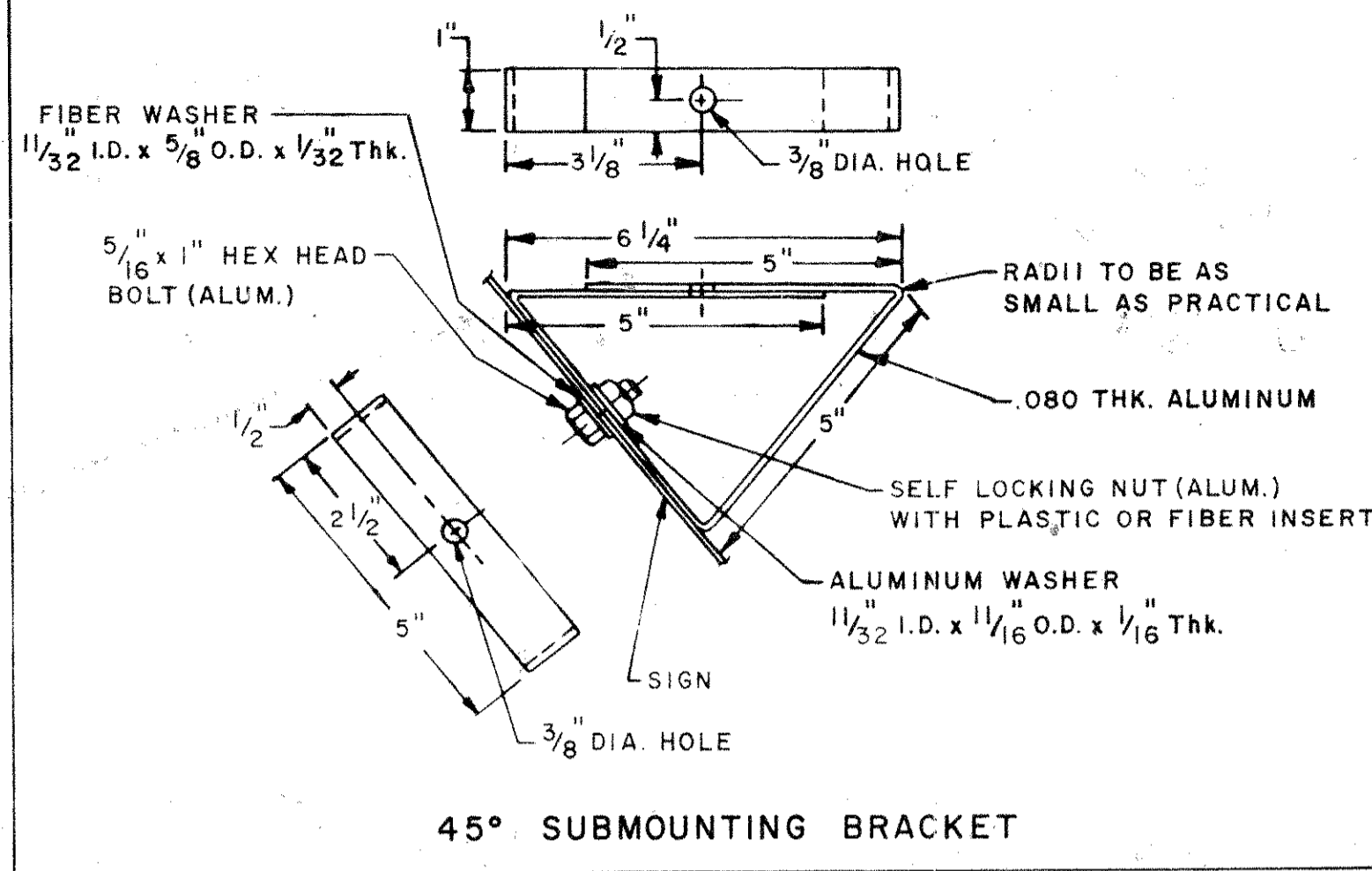
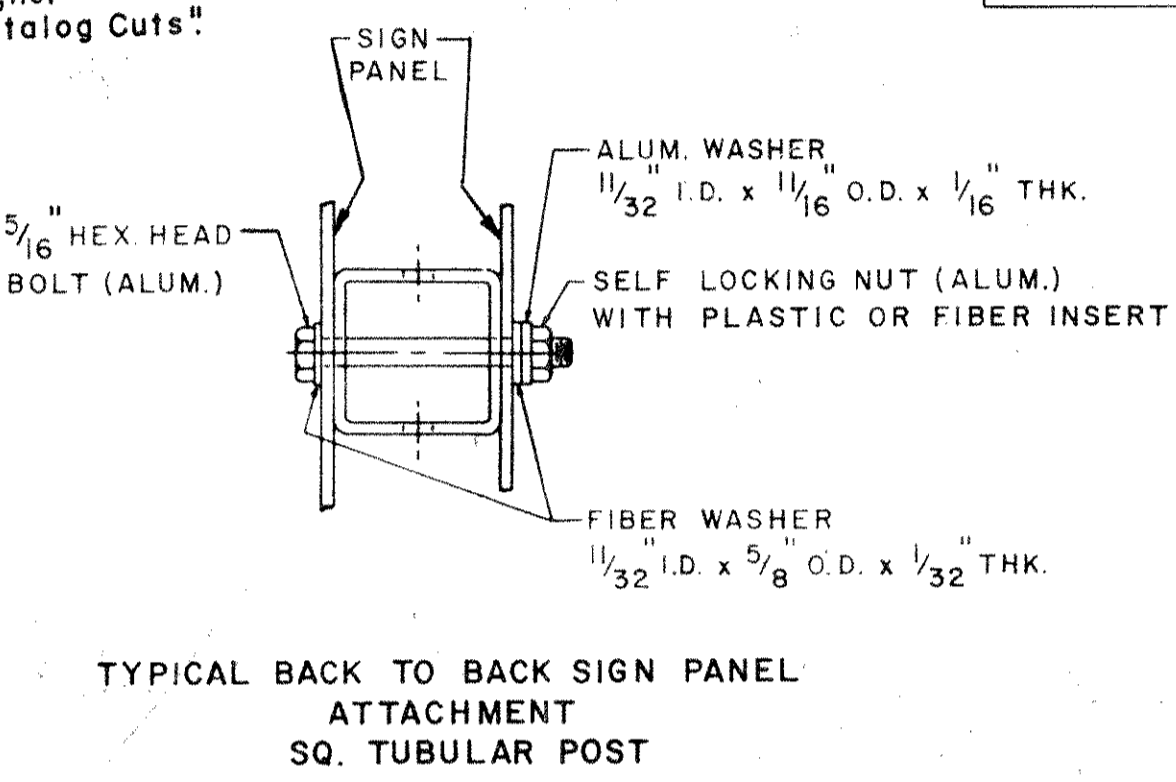
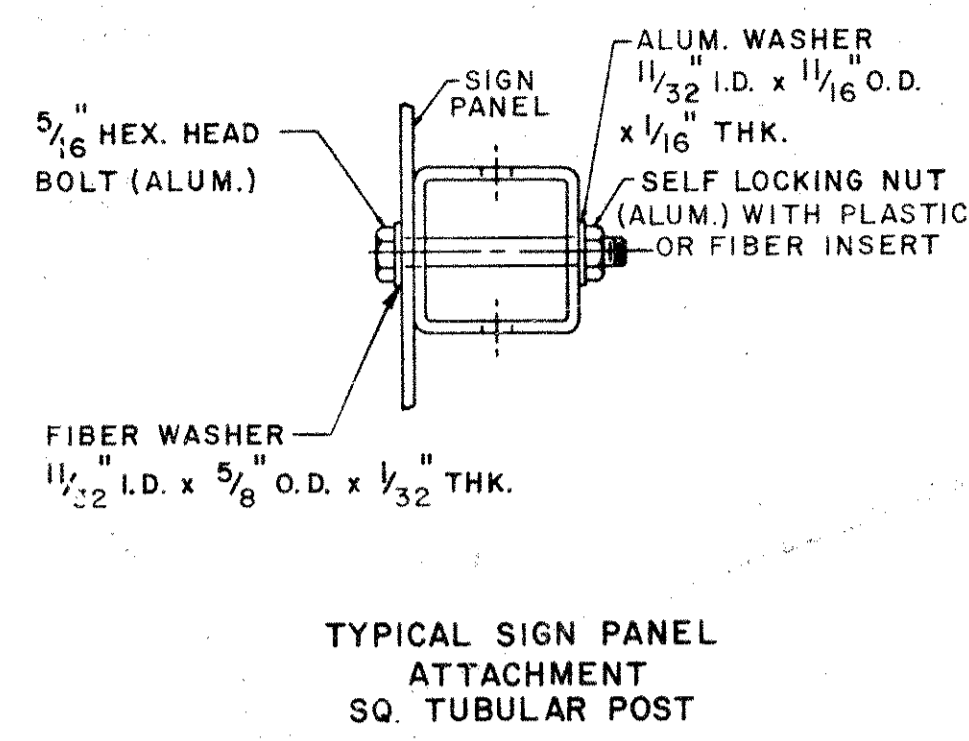
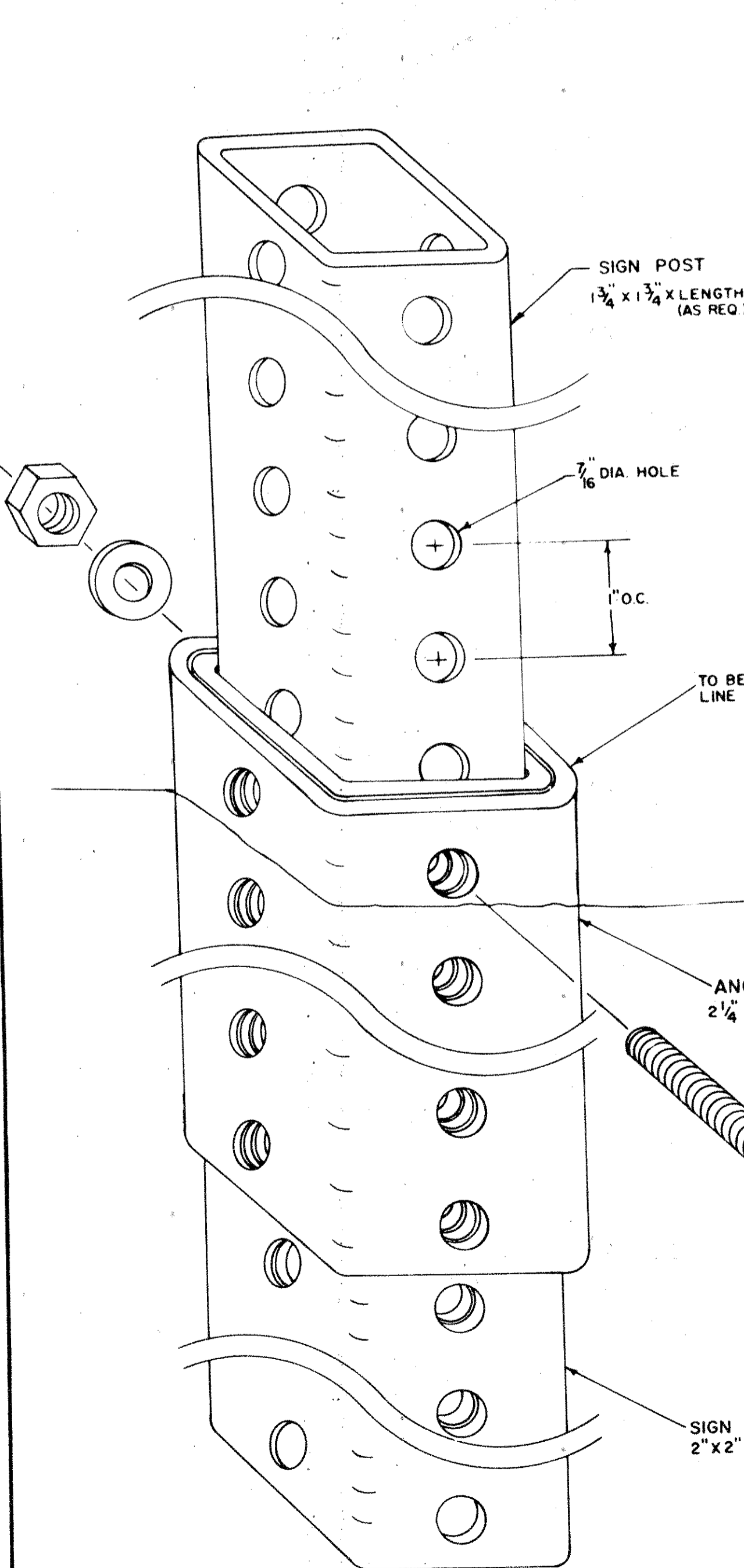

WT.	A	B	C
2 LB. OR	1 9/32	1 5/32	3 1/16
2 LB.	1 1/4	1.516	3 1/8
3 LB. OR	1 5/8	1 3/4	3 1/2
3 LB.	1 5/8	1 7/8	3 1/2
4 LB.	1 5/8	1 3/4	3 1/2

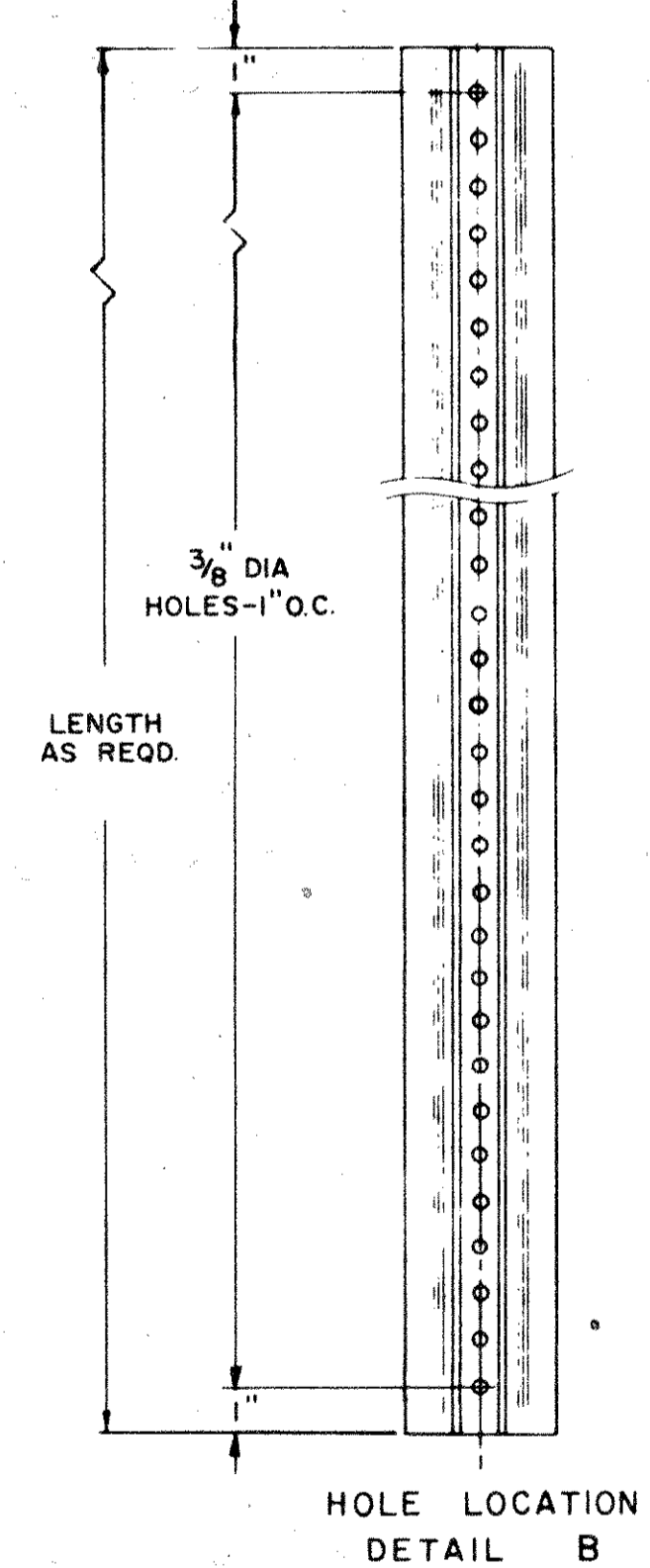

NOTES:
STEEL POSTS SHALL CONFORM TO THE REQUIREMENTS OF ASTM A-499 EXCEPT THAT BILLET STEEL MAY BE USED PROVIDED ALL OF THE MECHANICAL PROPERTIES OF ASTM A-499 ARE MET.
AFTER FABRICATION, ALL STEEL POSTS SHALL BE GALVANIZED TO MEET THE REQUIREMENTS OF ASTM A-123.

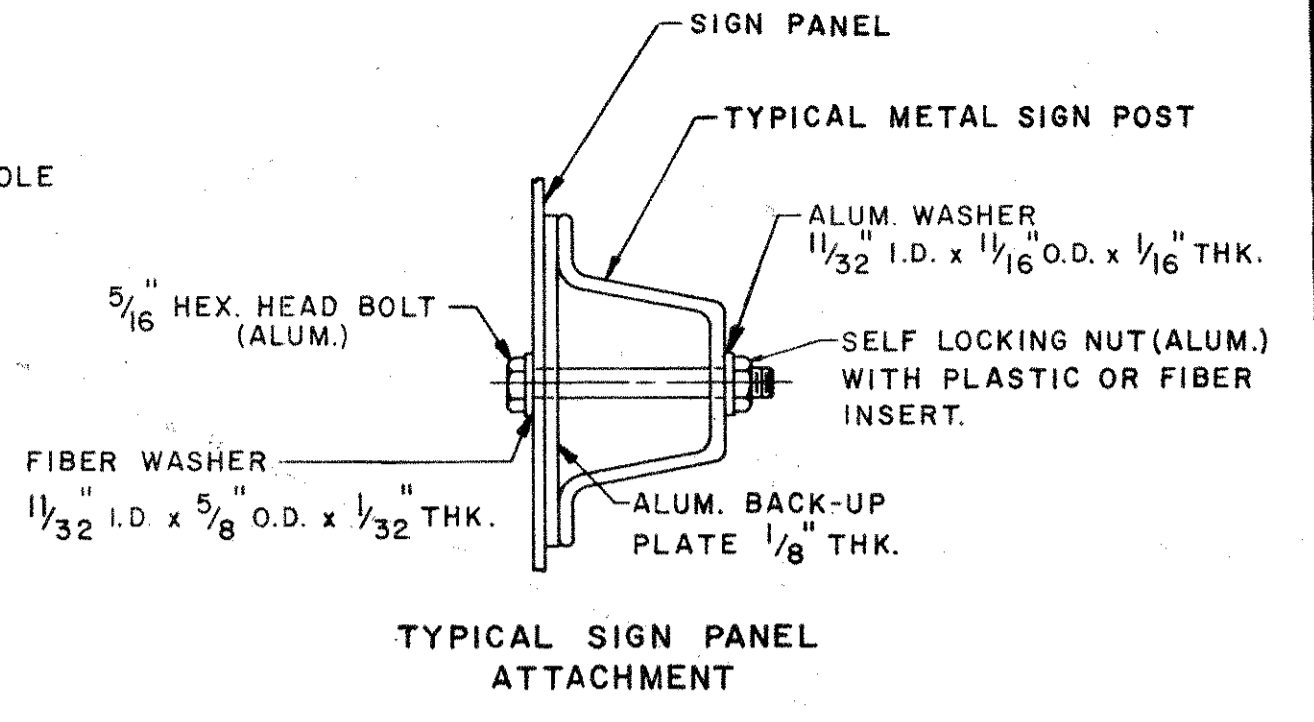
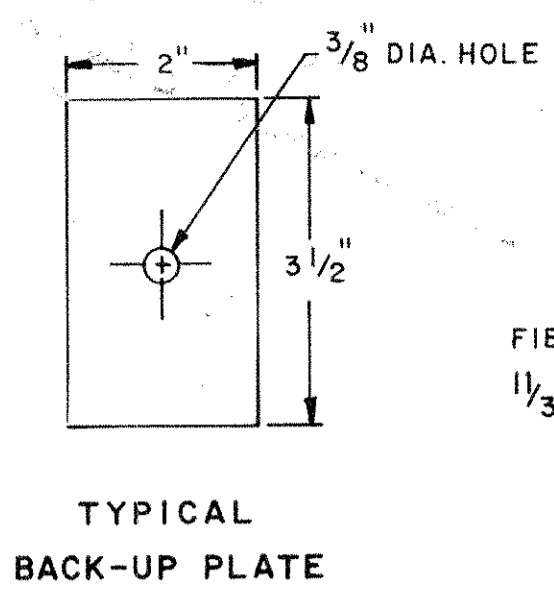

5/16" x 1" SAE J429 GRADE 5 BOLTS SHALL BE USED TO ASSEMBLE THE DOUBLE SECTION. BOLT SPACING: 16" ON CENTER ABOVE GROUND AND 4" ON CENTER BELOW GROUND LEVEL. ALL CONNECTING BOLTS SHALL BE TIGHTENED TO 30 FOOT POUNDS TORQUE.

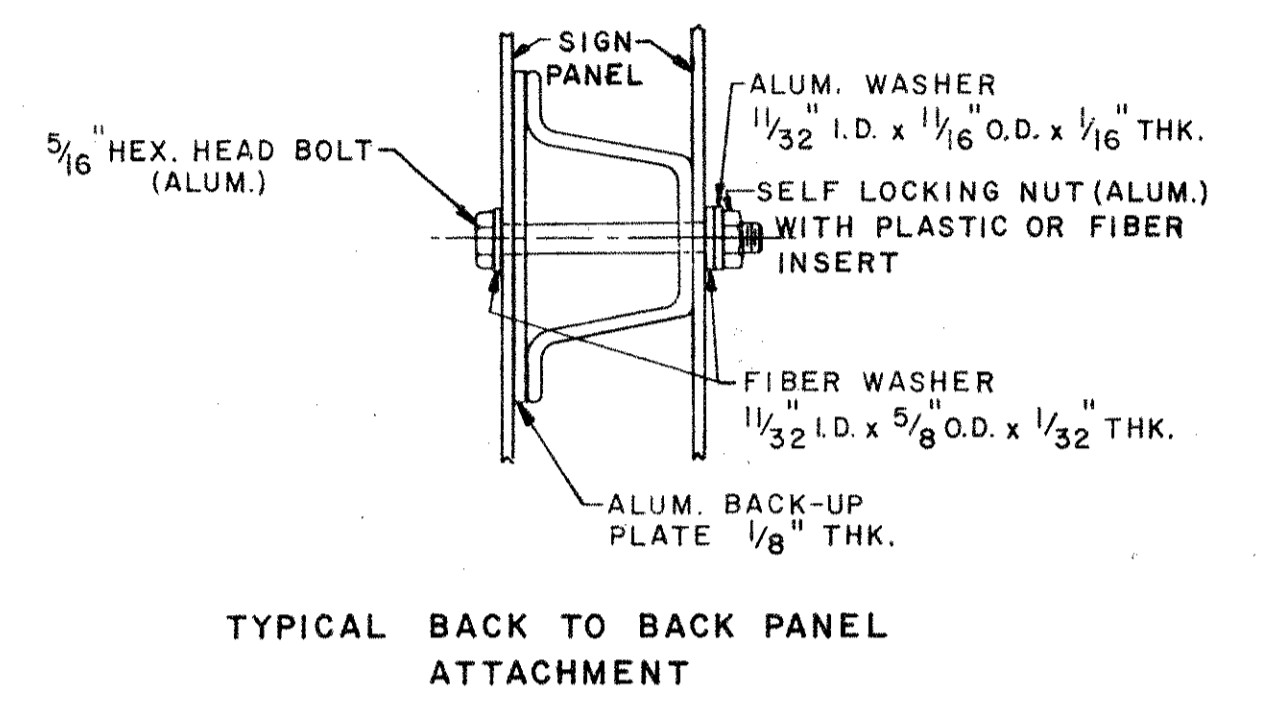
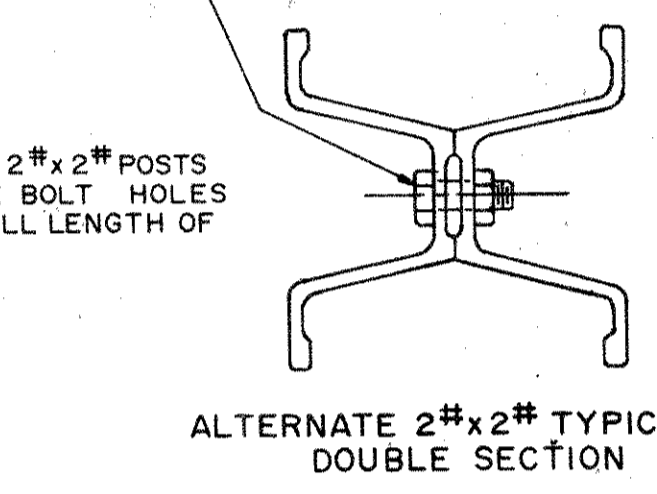

CONNECTICUT DEPARTMENT OF TRANSPORTATION BUREAU OF HIGHWAYS DIVISION OF TRAFFIC

TYPICAL METAL SIGN POSTS & SIGN MOUNTING DETAILS FOR SIGN FACE SHEET ALUMINUM

SUBMITTED BY *H. D. Jankowski* DATE *6-14-74*
APPROVED *J. A. Catalano* DATE *6-14-74*
Eng. of Traffic

REVISIONS		
NO.	DATE	DESCRIPTION
1	4-14-78	ASTM A-499 REF. ADDED
2	10-1-78	DOUBLE POST REMOVED
3	3-13-79	ADDED 45° ANGLE BRACKET
4	7-5-79	ADDED SIGN MOUNTING DETAILS
5	10-79	ADDED NOTE-SQ. TUBULAR SIGN SUPPORT
6	4-80	ADDED 2" POST
		MAX. SQ. FT. OF SIGN AREA REVISED FOR SQ. POSTS.

SCALE NONE

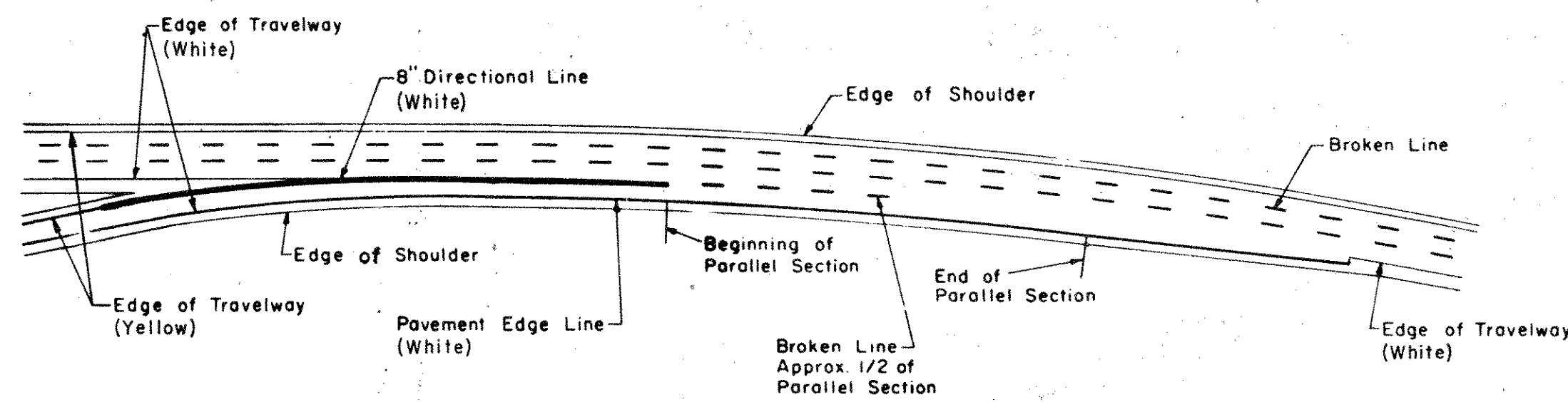

A TYPICAL ACCELERATION LANE →

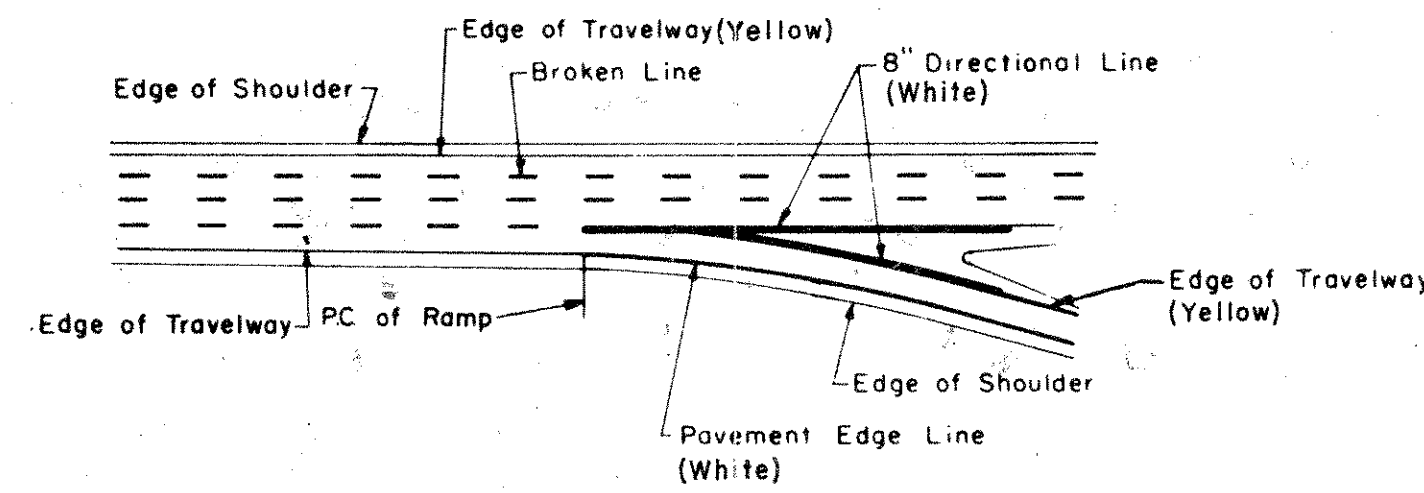

E TYPICAL LANE DROP →

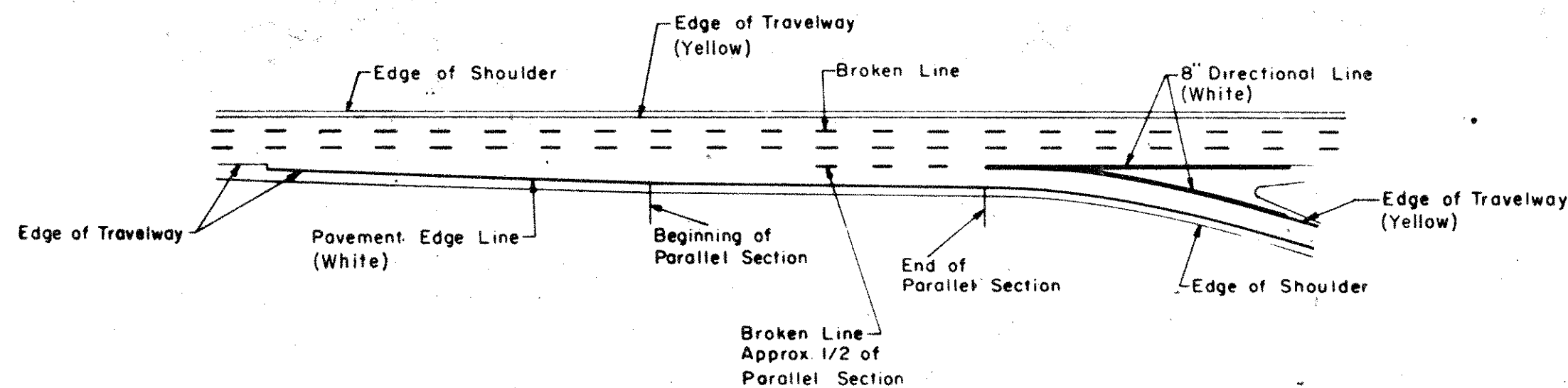

B TYPICAL DECELERATION LANE →

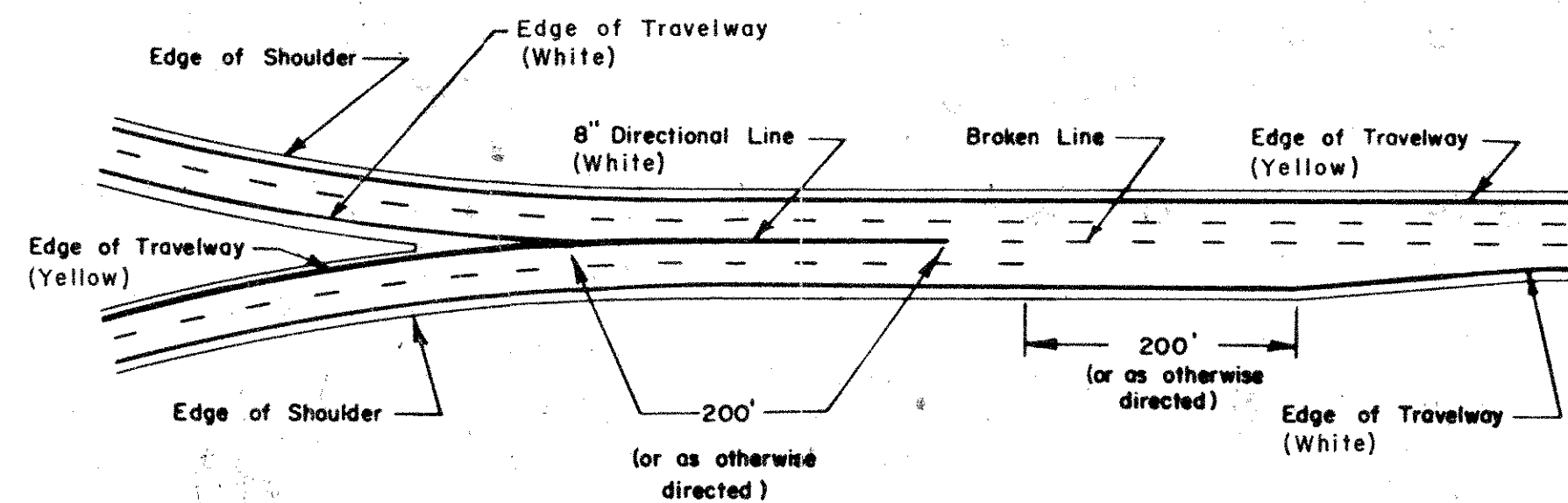

F TYPICAL MERGE →

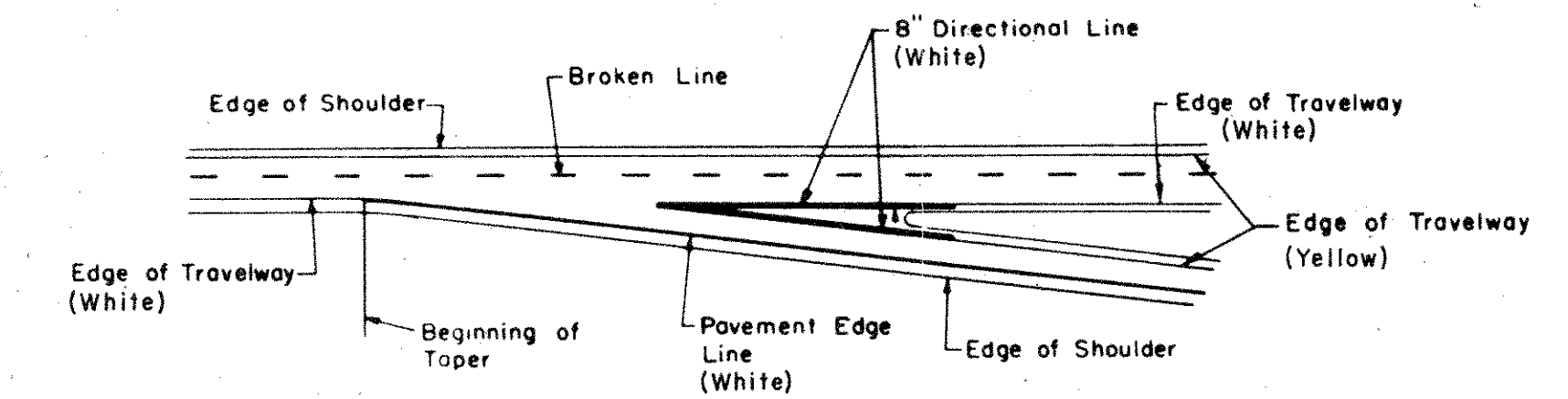

I TYPICAL TAPERED DECELERATION LANE →

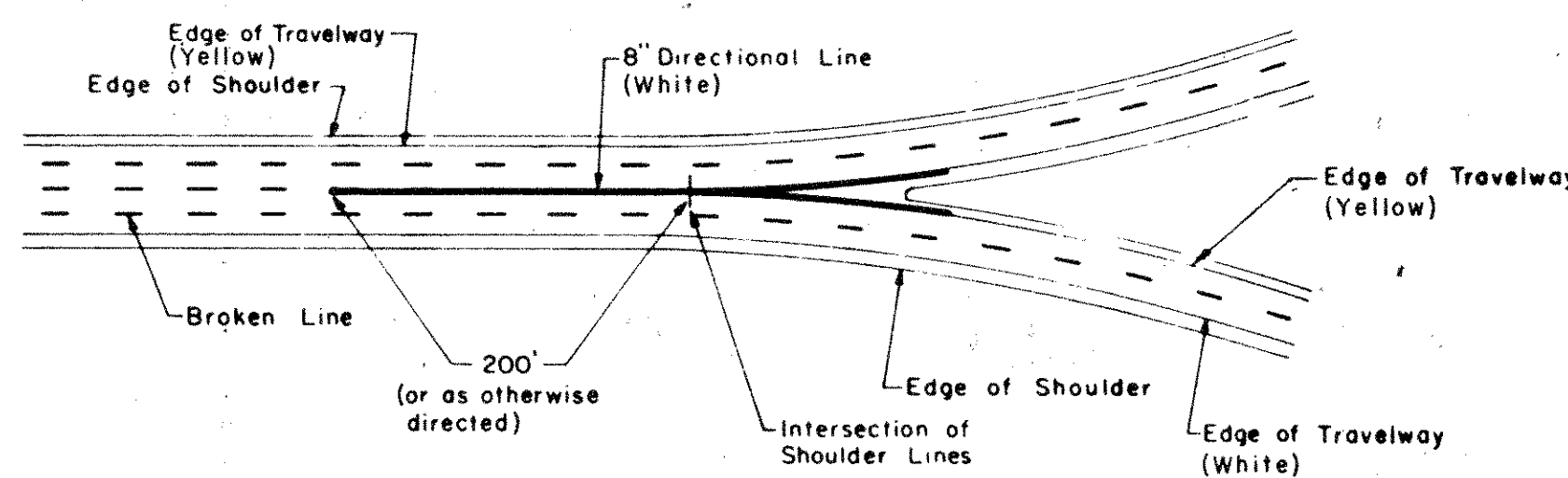

C FOUR LANE SPLIT →

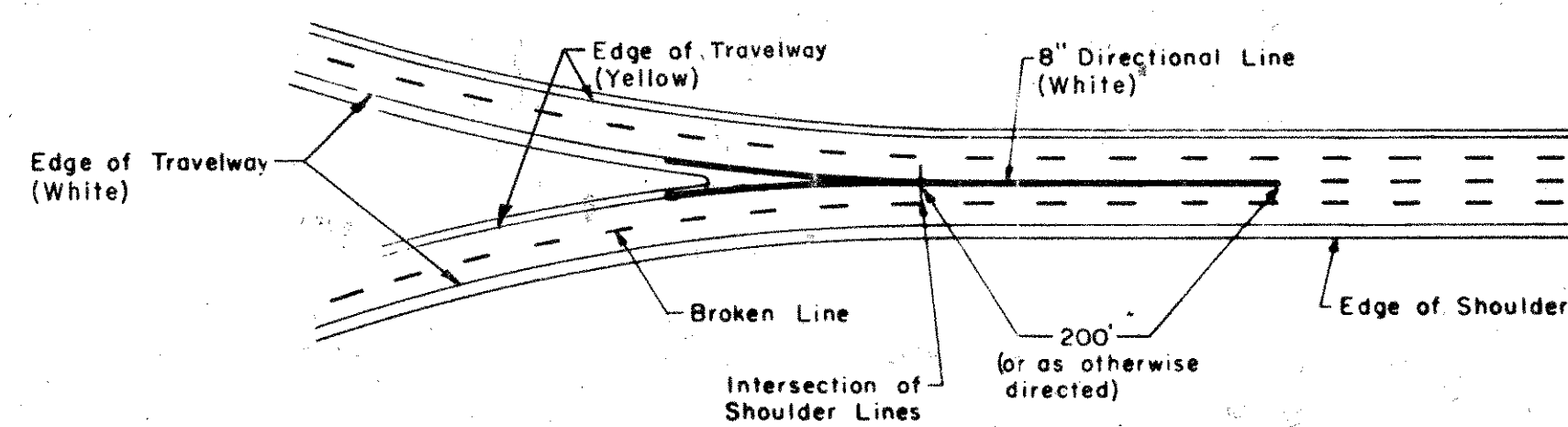

G TYPICAL MERGE TWO MAJOR ROADWAYS →

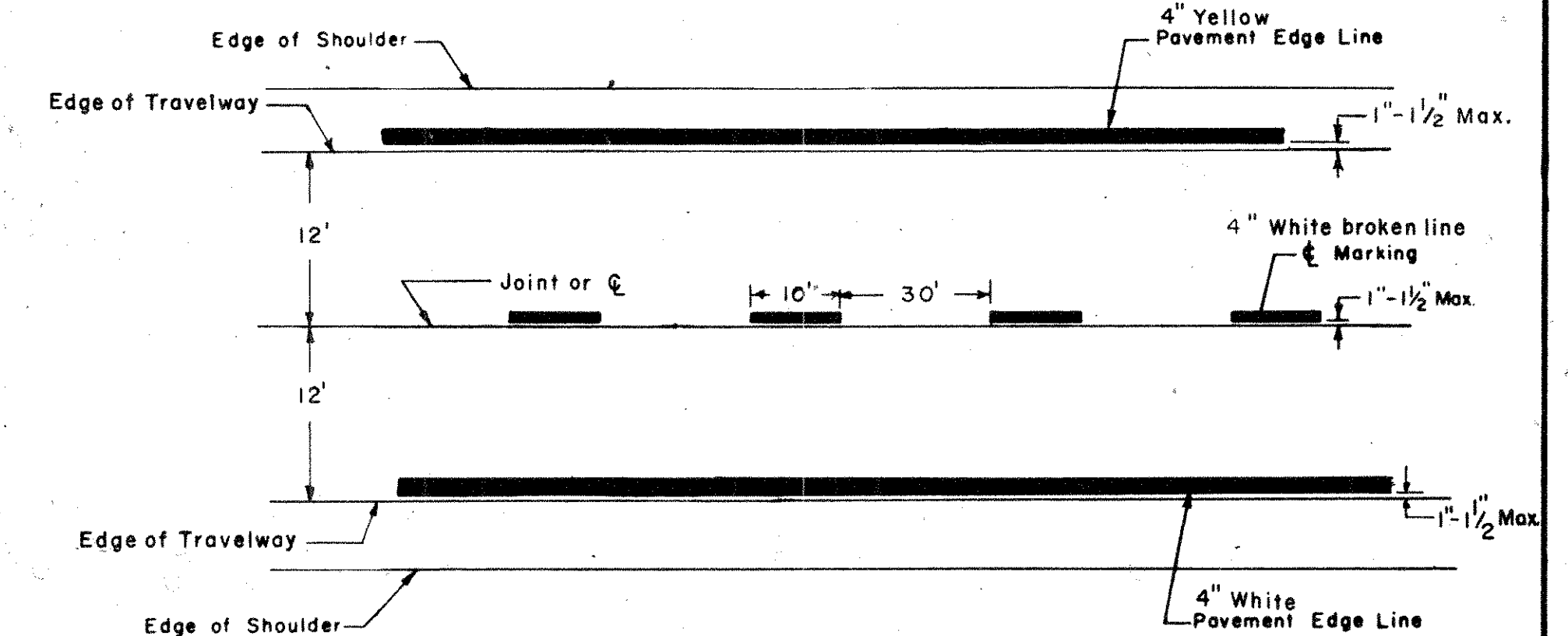

J DETAIL SHOWING PLACEMENT OF BROKEN LINES AND MARKINGS ON DIVIDED HIGHWAYS

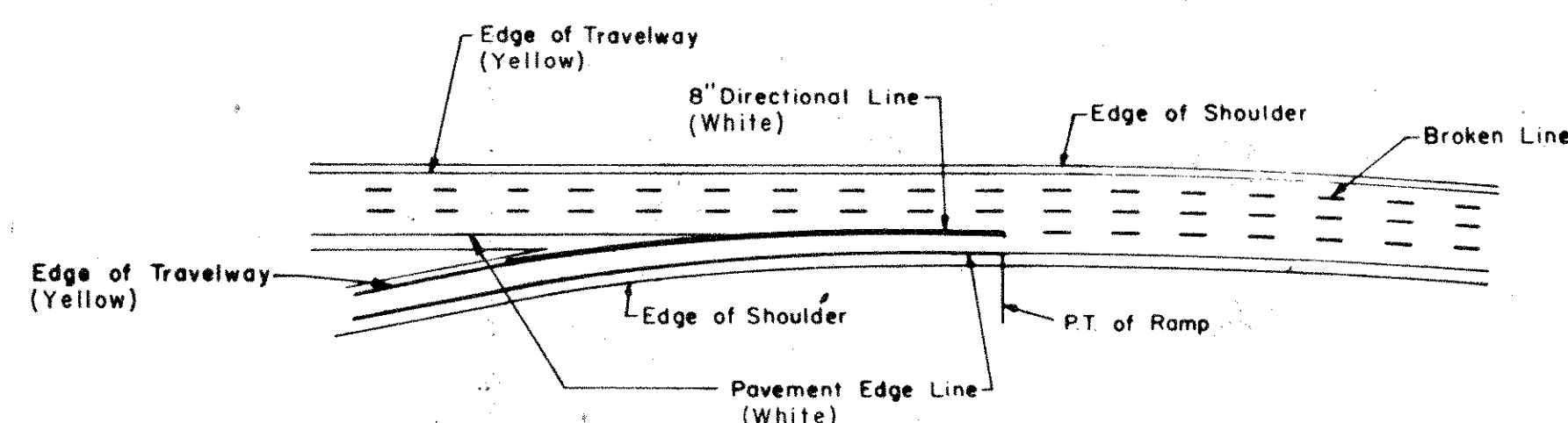

D TYPICAL LANE ADDITION →

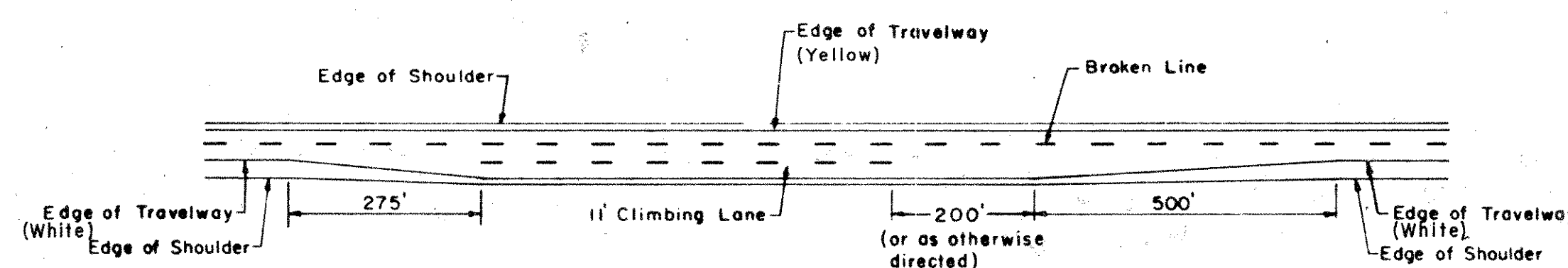

H TYPICAL CLIMBING LANE →

GENERAL NOTES:

Broken Line in Parallel Section of Ramp is Placed to the Right of Longitudinal Joint.
Broken Line in Climbing Lane is Placed in Alignment with Pavement Edge Line.

NOTE:

1. PREFORMED PLASTIC PAVEMENT MARKINGS NOT TO BE INSTALLED ON METAL SURFACES SUCH AS EXPANSION JOINTS, MANHOLE COVERS AND UTILITY GATE COVERS.

DENOTES DIRECTION OF TRAVEL →

CONNECTICUT
DEPARTMENT OF TRANSPORTATION
BUREAU OF HIGHWAYS
DIVISION OF TRAFFIC

TYPICAL PAVEMENT MARKINGS
FOR DIVIDED HIGHWAYS

REVISIONS		
NO.	DATE	DESCRIPTION
1	7-15-74	Revised Detail J
2	2-4-77	ADD PAV. EDGE LINE COLORS
3	6-15-79	RELOCATED YELLOW PAV. EDGE LINE IN VIEW (D)
4	9-79	ADDED PLASTIC PAV. MARKING NOTE
5	2-80	LANE LINE SPACING REVISED TO 10' - 30'
6	7-80	6\"/>

SUBMITTED BY: *J. O. Kashmir* DATE: 3-28-73
APPROVED: *J. P. ...* DATE: 3-28-73
Eng. of Traffic

SCALE: NONE

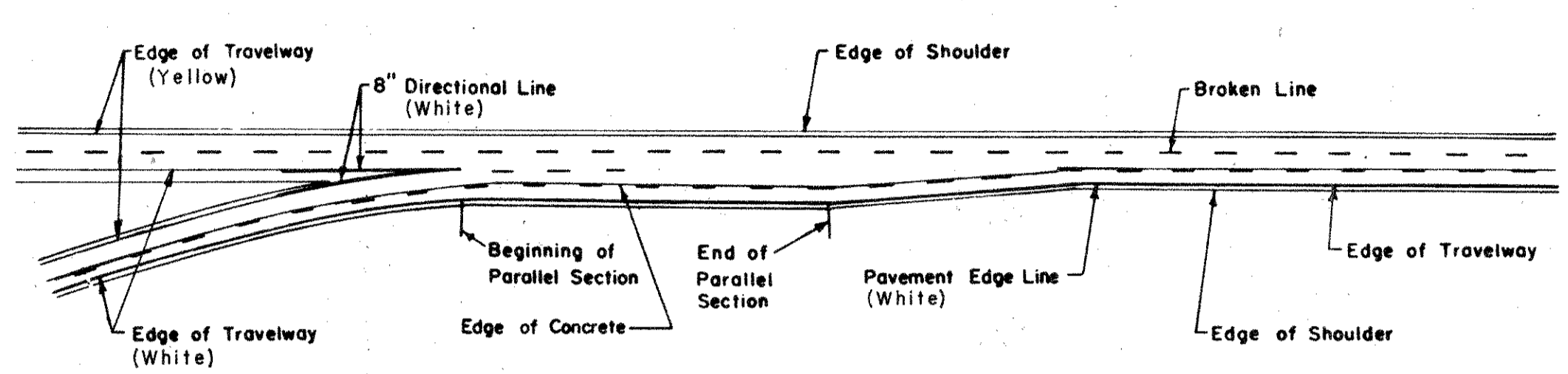

K TREATMENT OF CLIMBING LANE - ENTERING FROM RAMP →

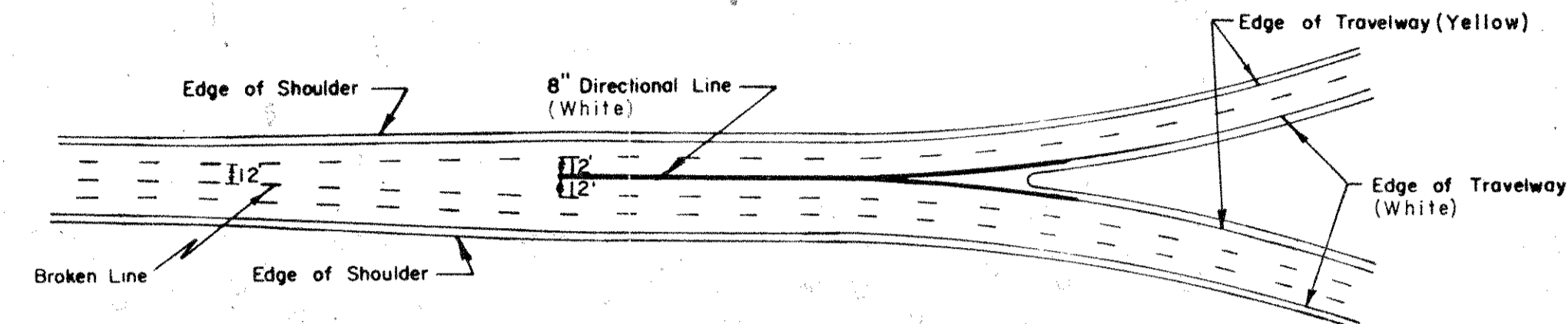

N TYPICAL BIFURCATION →

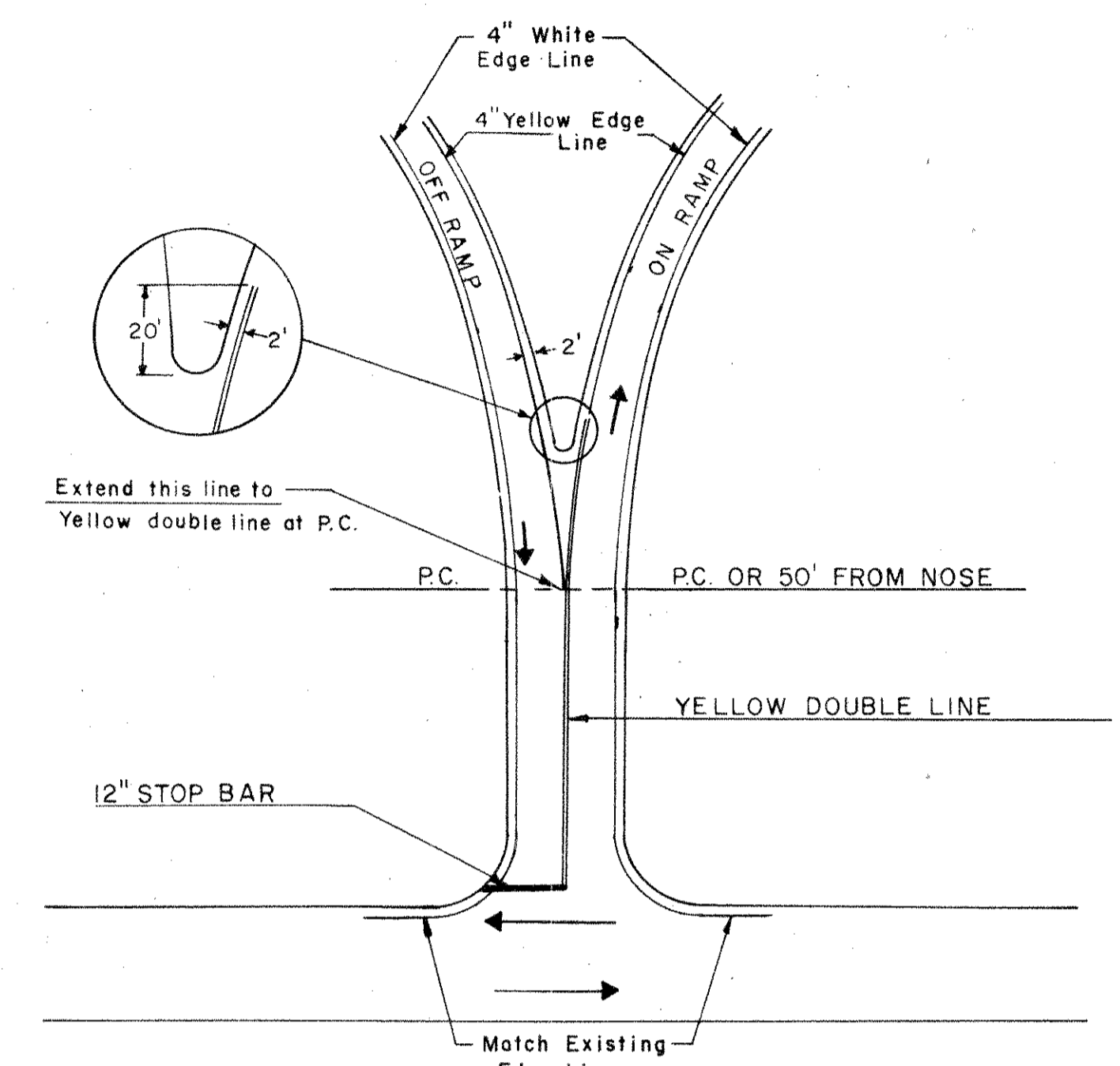

P TYPICAL CENTERLINE MARKING ON ABUTTING RAMPS AT INTERSECTING ROADWAYS

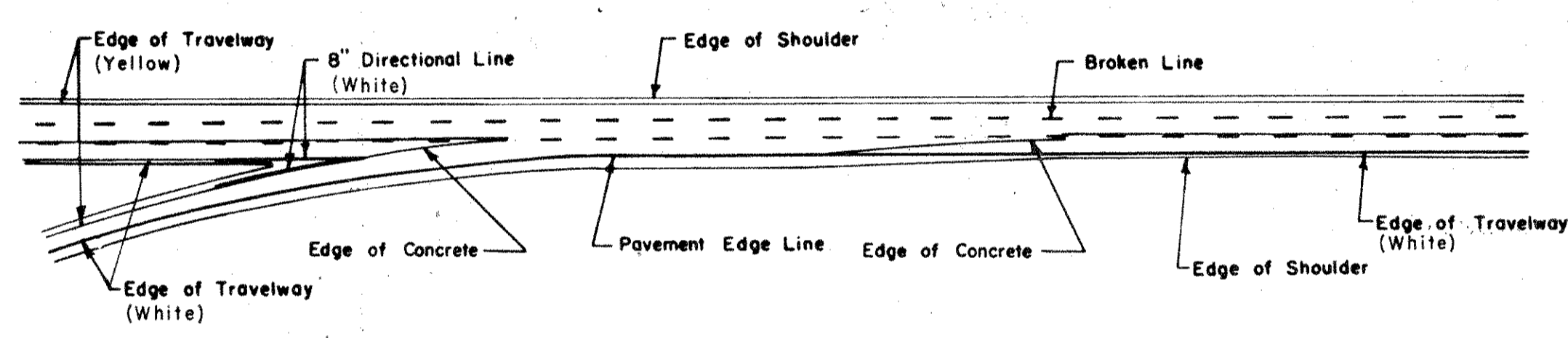

L TREATMENT OF CLIMBING LANE - THROUGH ACCELERATION LANE →

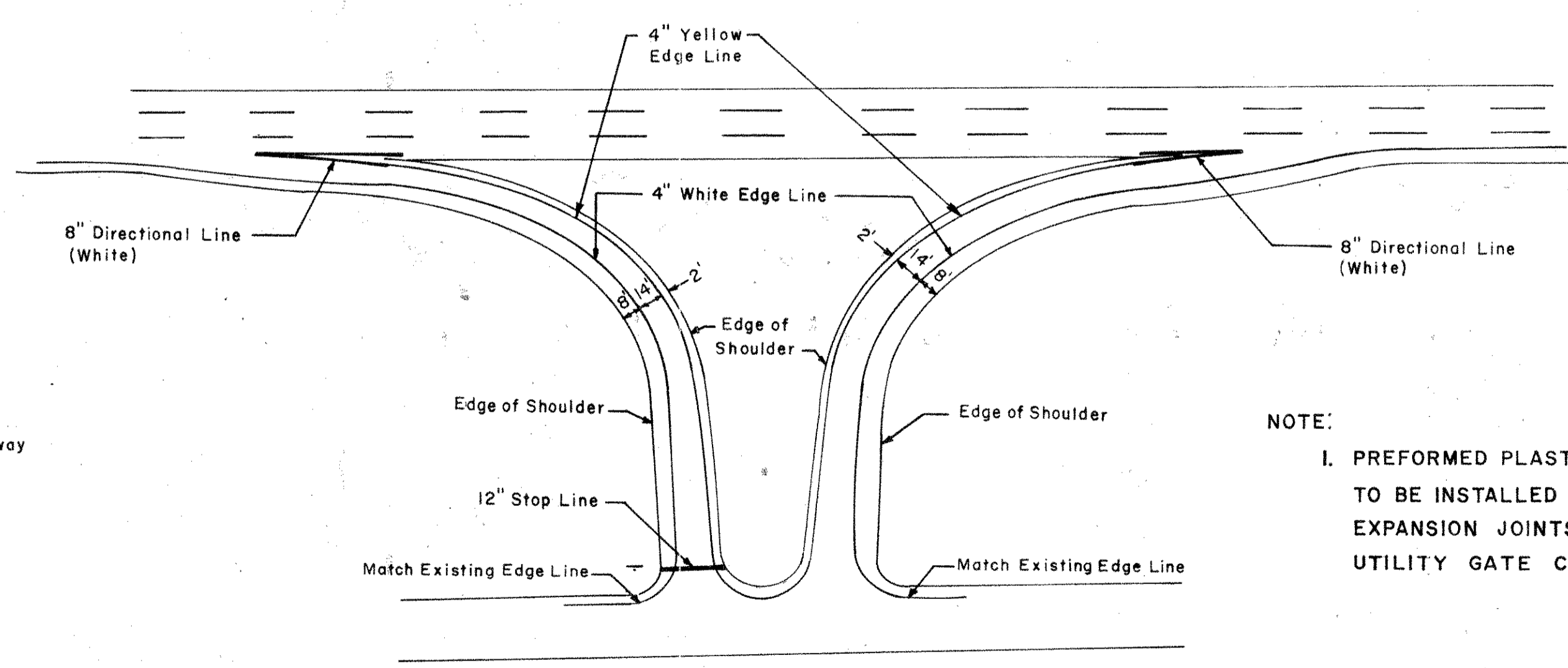

O TYPICAL RAMP TREATMENT →

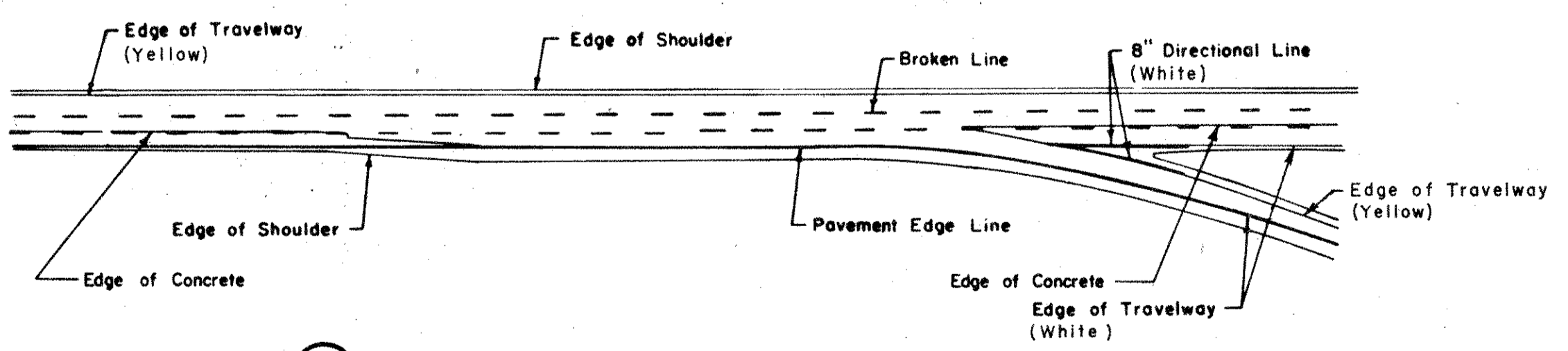

M TREATMENT OF CLIMBING LANE - THROUGH DECELERATION LANE →

NOTE:
1. PREFORMED PLASTIC PAVEMENT MARKINGS NOT TO BE INSTALLED ON METAL SURFACES SUCH AS EXPANSION JOINTS, MANHOLE COVERS AND UTILITY GATE COVERS.

→ DENOTES DIRECTION OF TRAVEL

CONNECTICUT
DEPARTMENT OF TRANSPORTATION
BUREAU OF HIGHWAYS
DIVISION OF TRAFFIC

TYPICAL PAVEMENT MARKINGS
FOR DIVIDED HIGHWAYS

REVISIONS		
NO.	DATE	DESCRIPTION
1	7-15-74	Added Details O & P
2	2-4-77	ADD PAV. EDGE LINE COLORS
3	9-79	ADDED PLASTIC PAV. MARKING NOTE

SUBMITTED BY *J. G. Gorkovskoff* DATE *3-28-72*
APPROVED *J. Catalano* DATE *3-28-73*
Eng. of Traffic

SCALE NONE

FHWA REGION	STATE	TOWN	FED AID PROJ. NO.	PROJ. NO.	YEAR	ROUTE NO.	SHEET NO.	TOTAL SHEETS
1	CONN	Southington-Hartford		131-145	1983	84	115-1	115

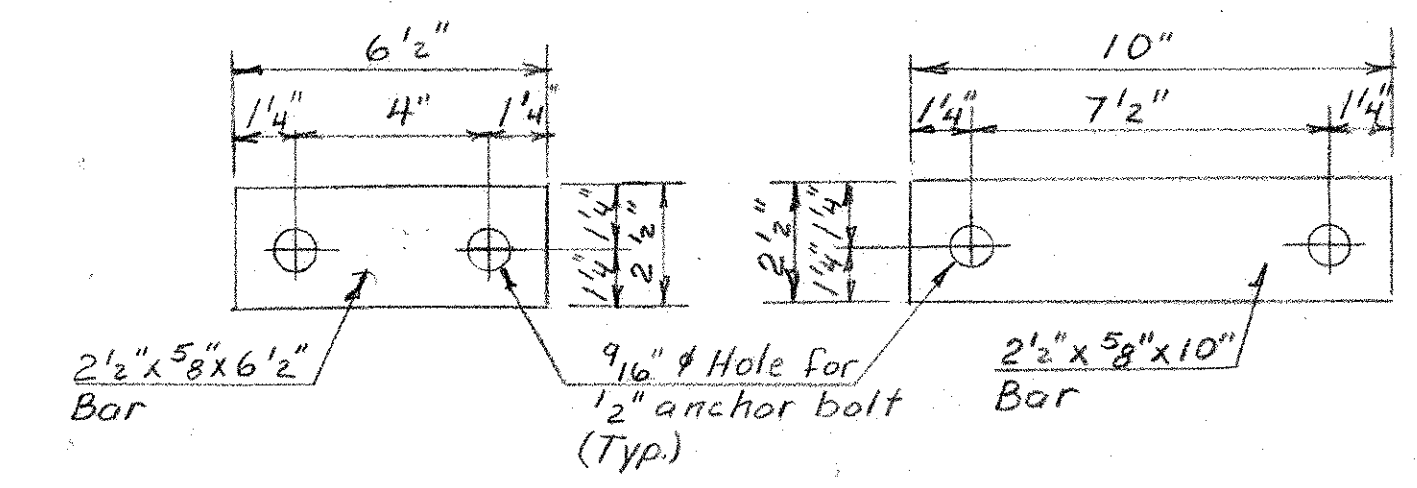
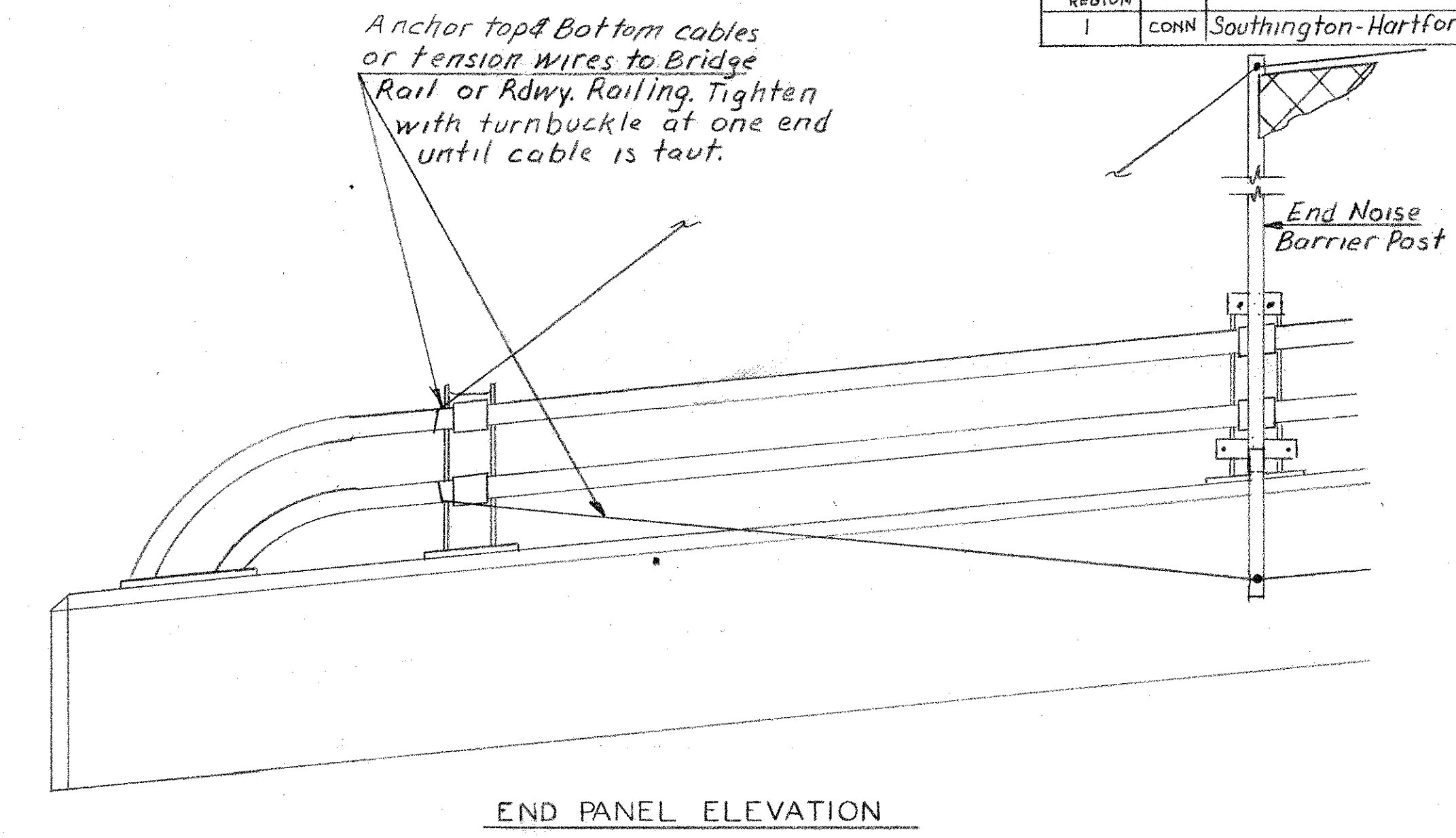
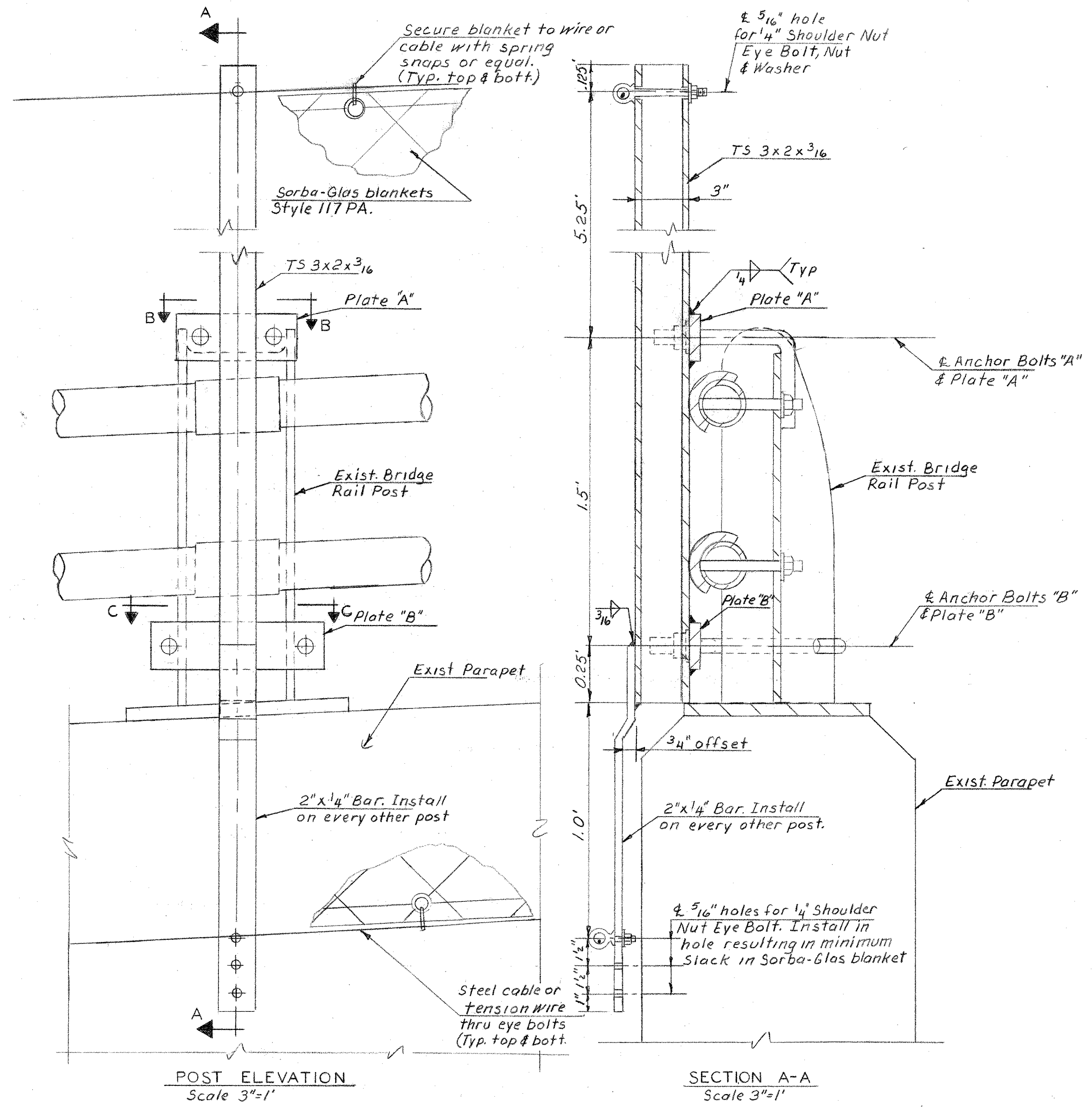

Notes:
 Blankets to be installed with quilted side facing the roadway.
 Adjacent blankets to be joined together according to the directions of the Manufacturer.
 Blankets shall be removed during high winds.
 Posts shall be installed at every bridge rail post.

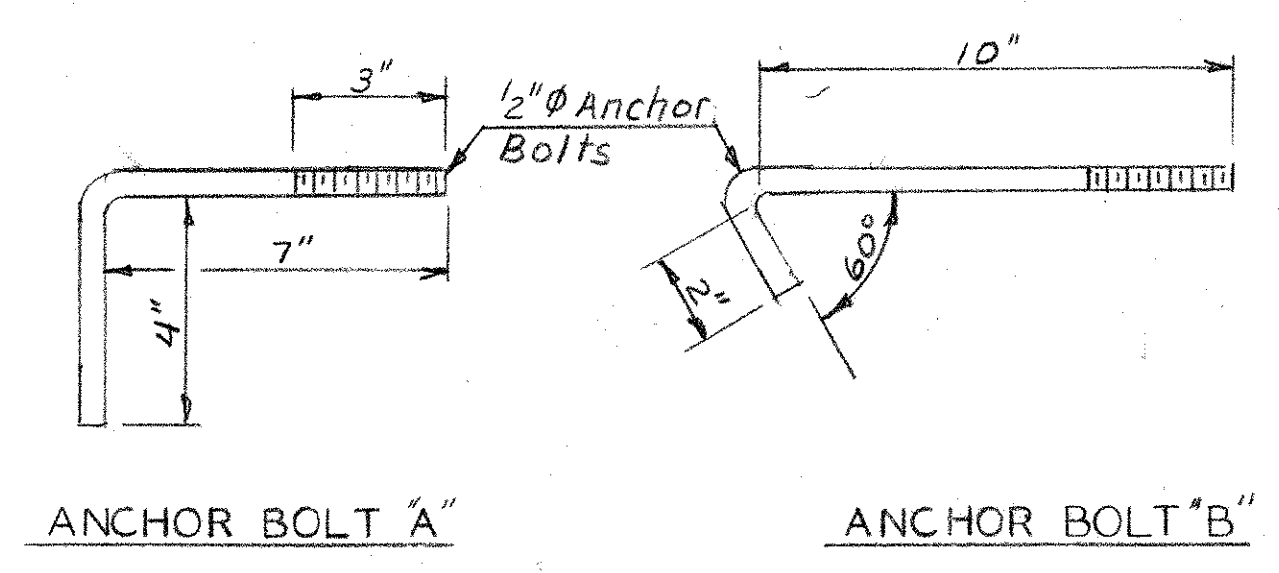
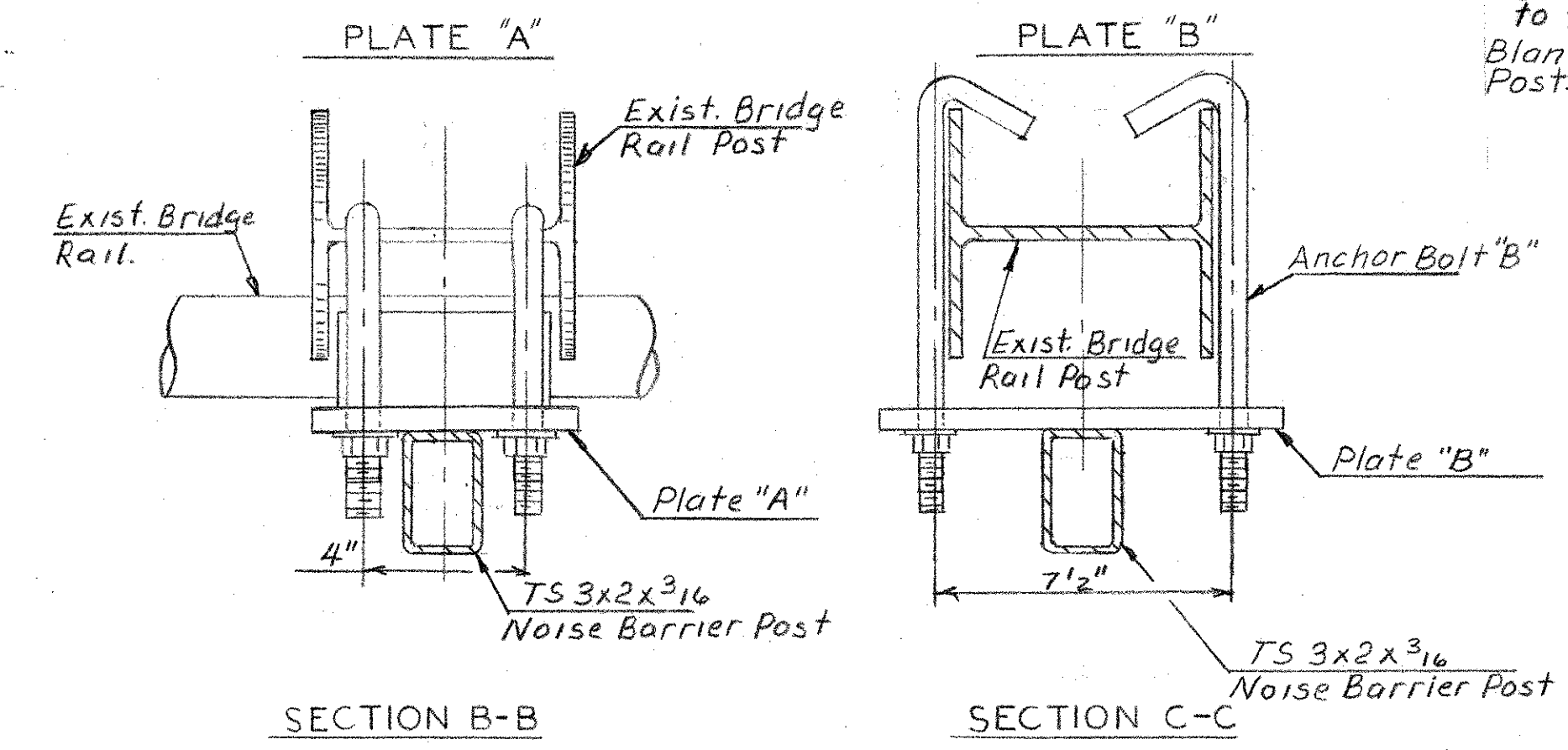

The information, including estimated quantities of work shown on these sheets is based on limited investigations by the State and is in no way warranted to indicate the true conditions or actual quantities or distribution of quantities of work which will be required.

STATE OF CONNECTICUT DEPARTMENT OF TRANSPORTATION SOUTHINGTON - HARTFORD INTERSTATE ROUTE 84 59 STRUCTURES DECK REPAIRS TEMPORARY NOISE BARRIER		
ENGINEER BRIDGE DESIGN UNIT		
DESIGNER G.D.B.	DRAFTER G.D.B.	CHECKER <i>TK</i>
APPROVED <i>[Signature]</i>	DATE 7/12/83	
STR. SH. NO. 1 OF 1		

131 145

505 01

115-1

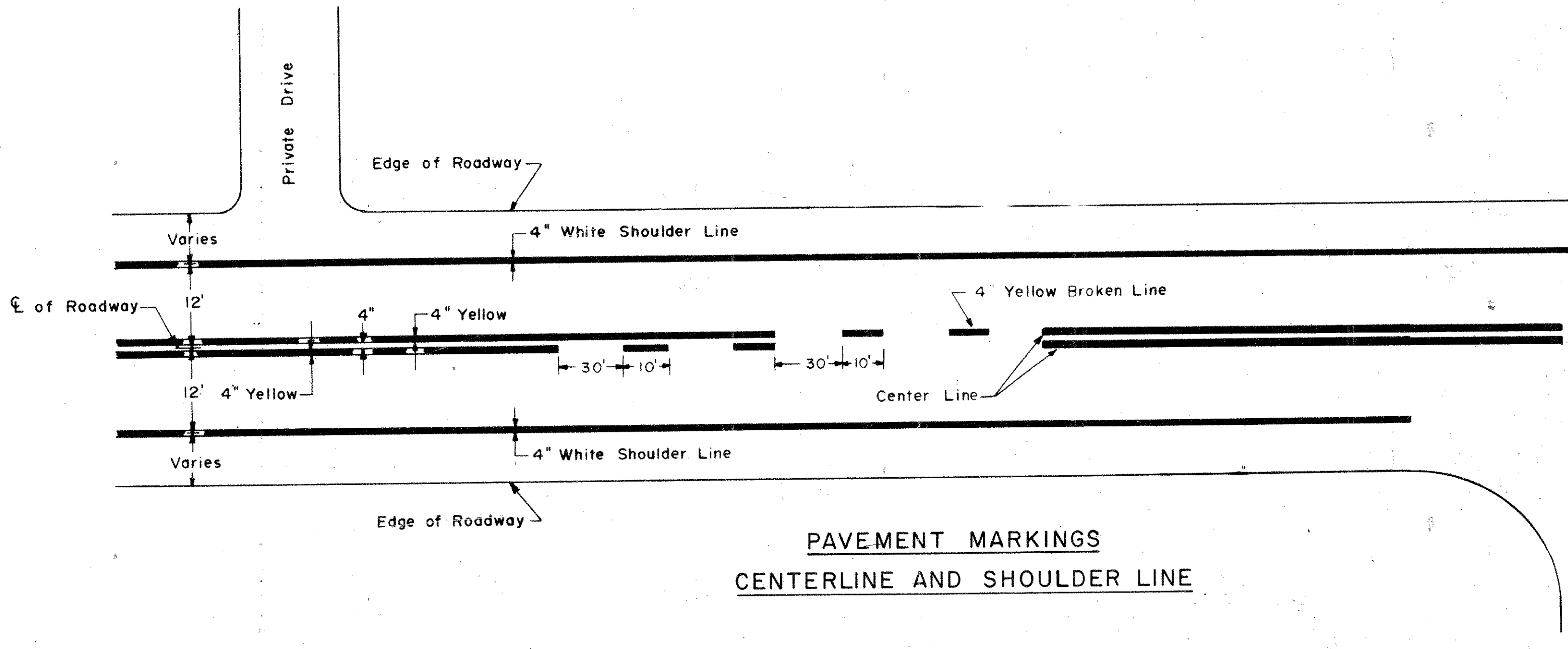

**PAVEMENT MARKINGS
CENTERLINE AND SHOULDER LINE**

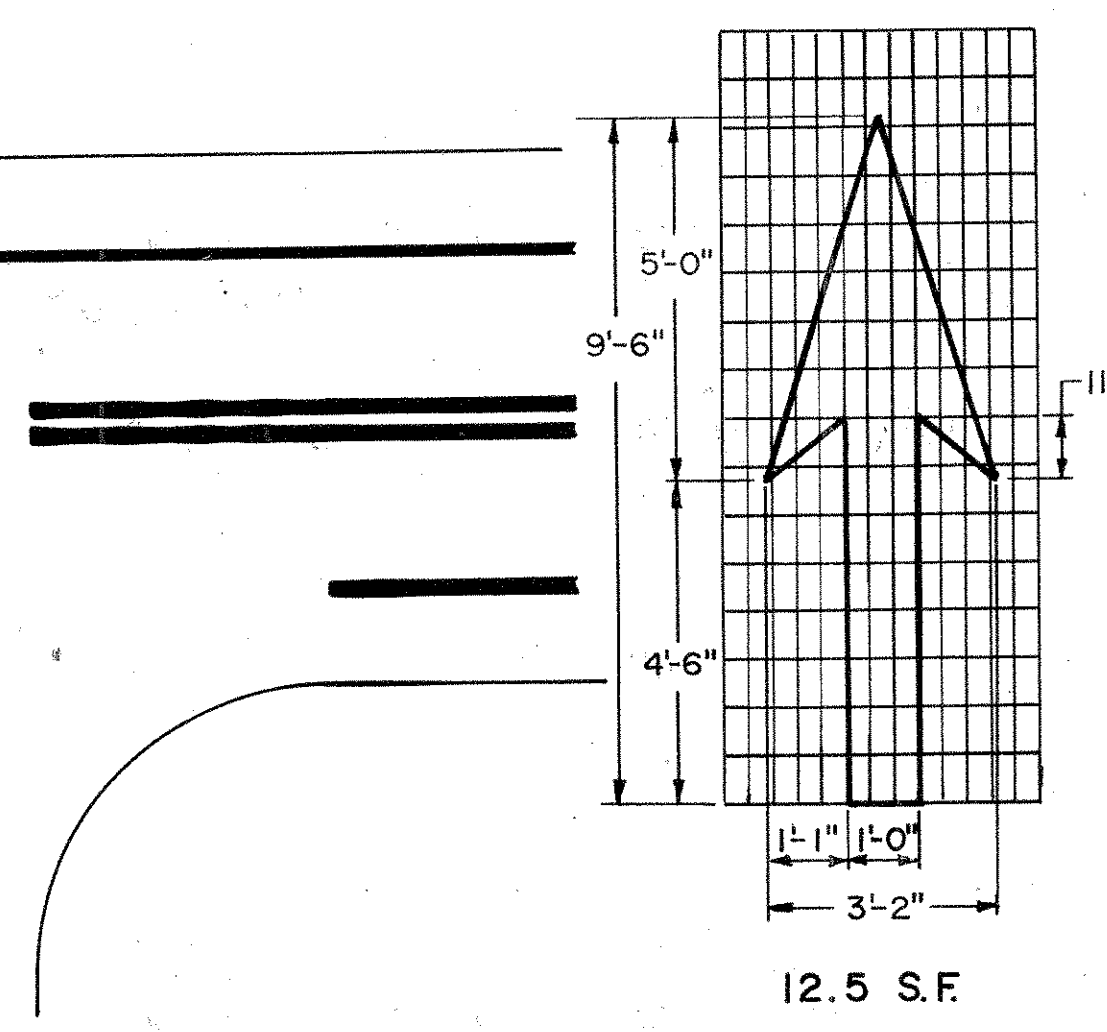

12.5 S.F.

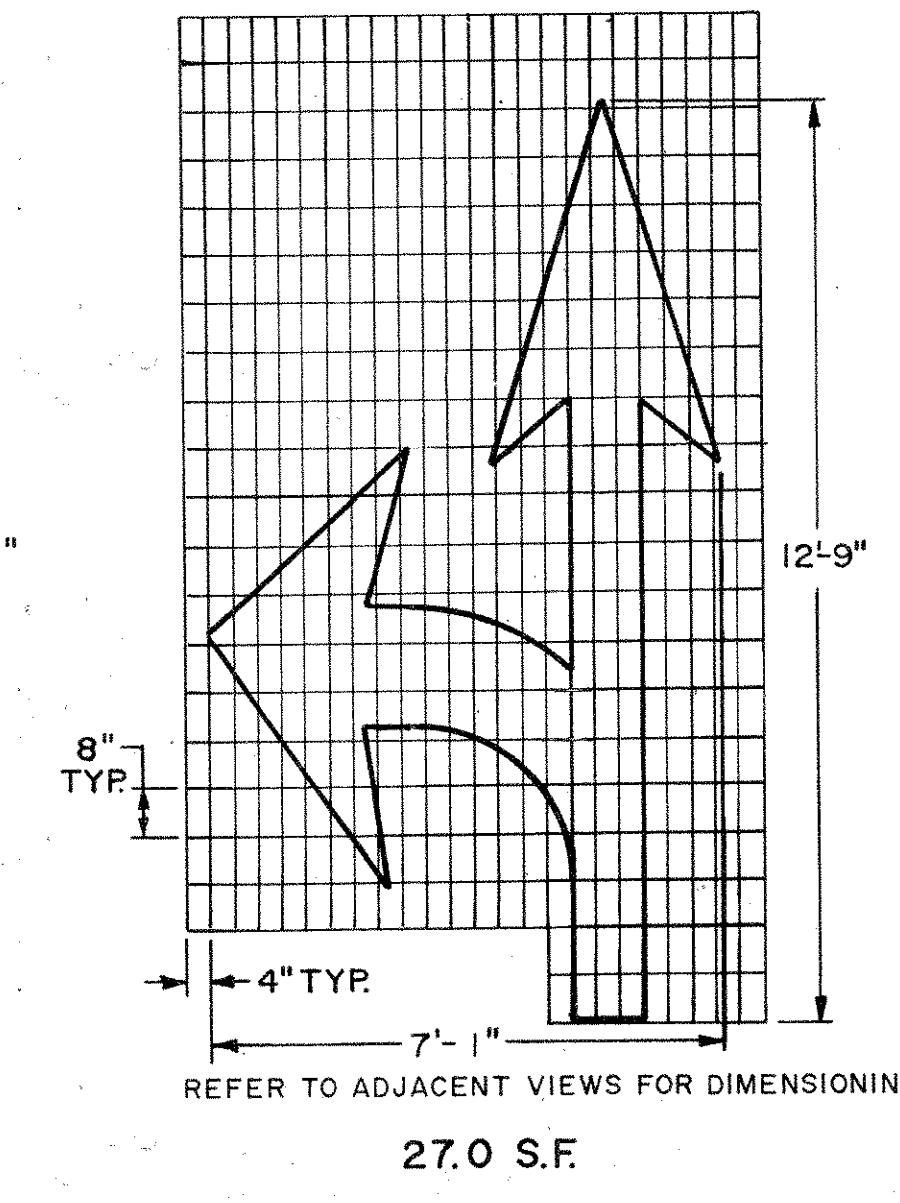

27.0 S.F.

**PAVEMENT ARROW DETAILS
(WHITE)**
(ARROWS TO BE CENTERED IN TRAVEL LANE)

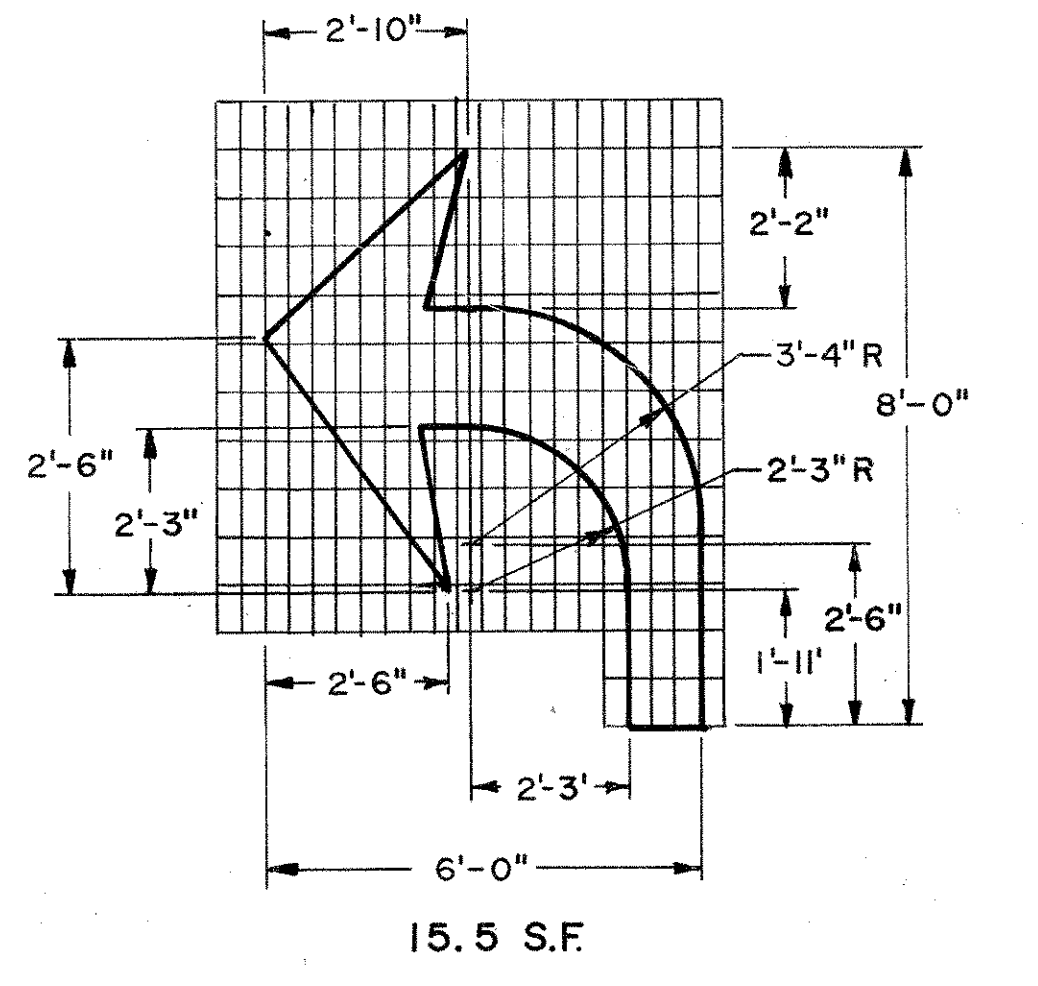

15.5 S.F.

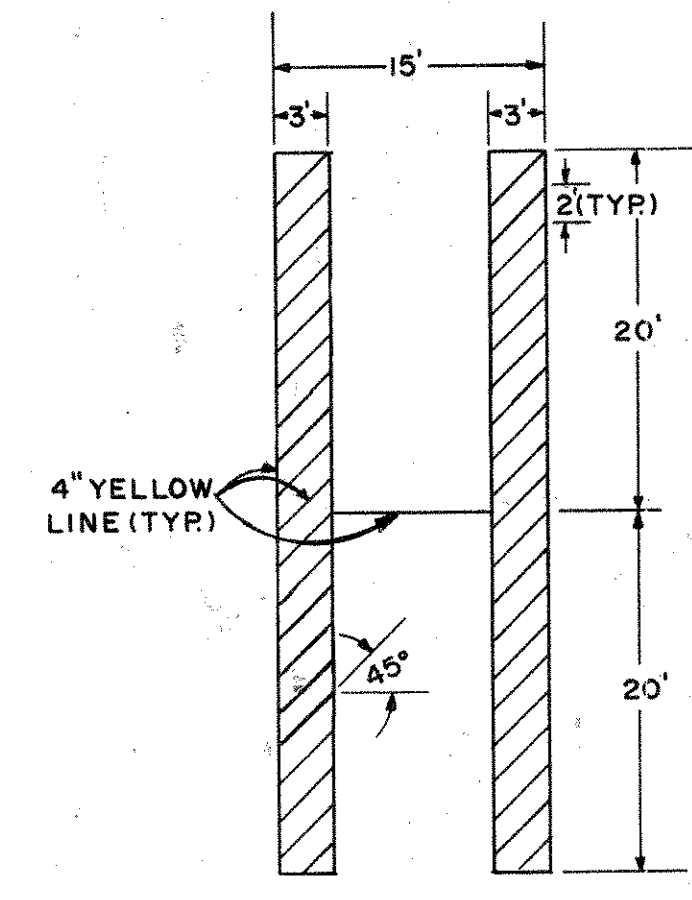
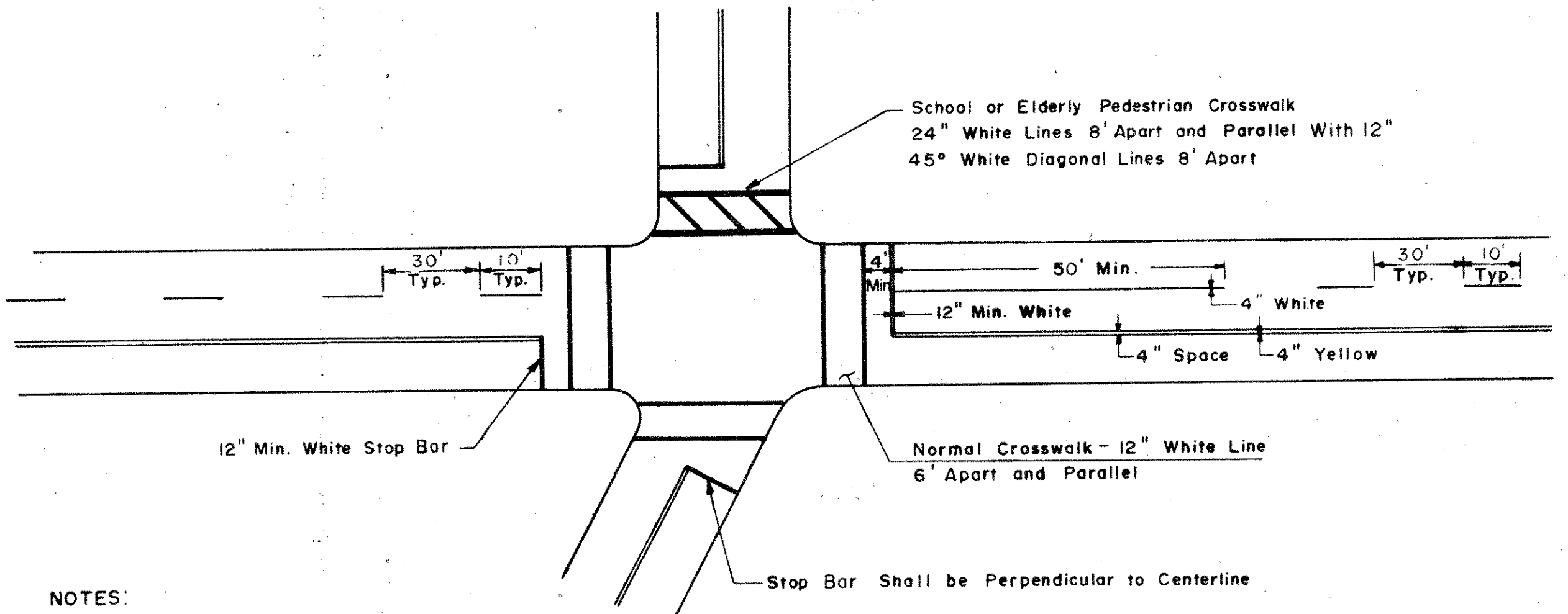

(PIGGY BACK STYLE)

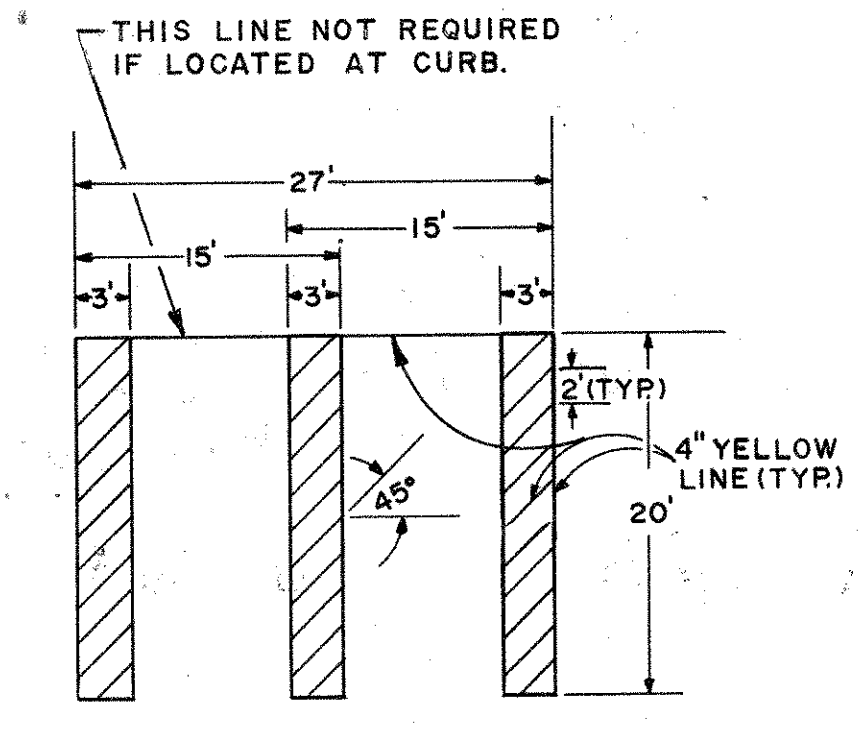

(SIDE BY SIDE STYLE)

PARKING STALLS FOR HANDICAPPED

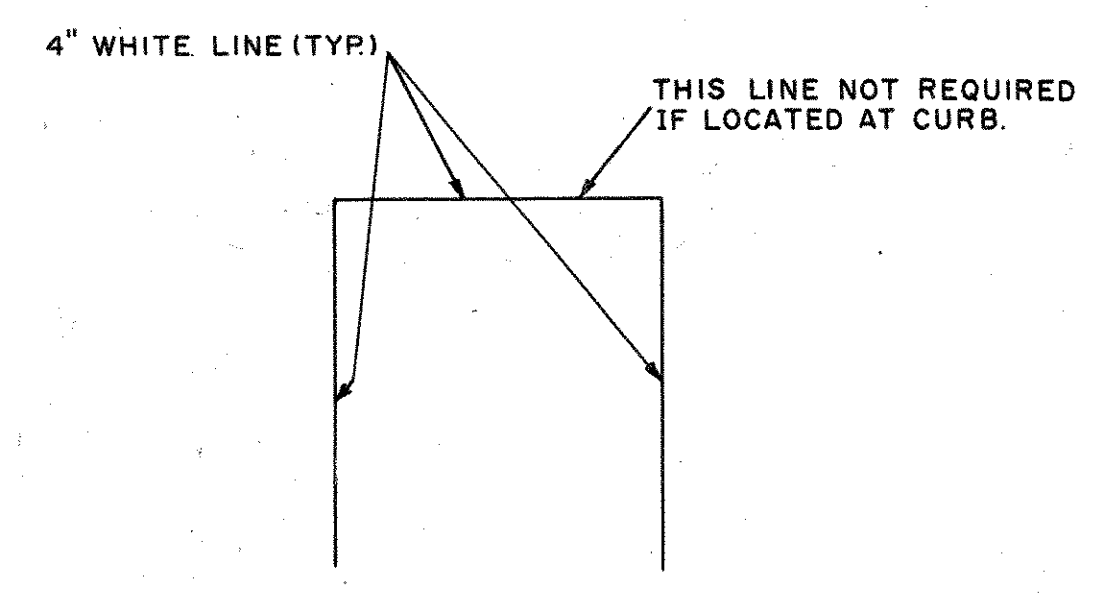

STANDARD PARKING STALL

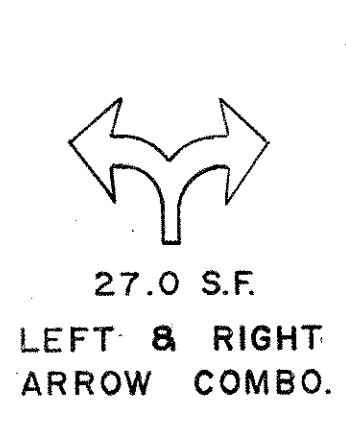

27.0 S.F.
LEFT & RIGHT
ARROW COMBO.

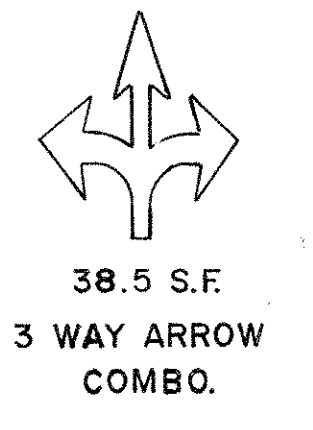

38.5 S.F.
3 WAY ARROW
COMBO.

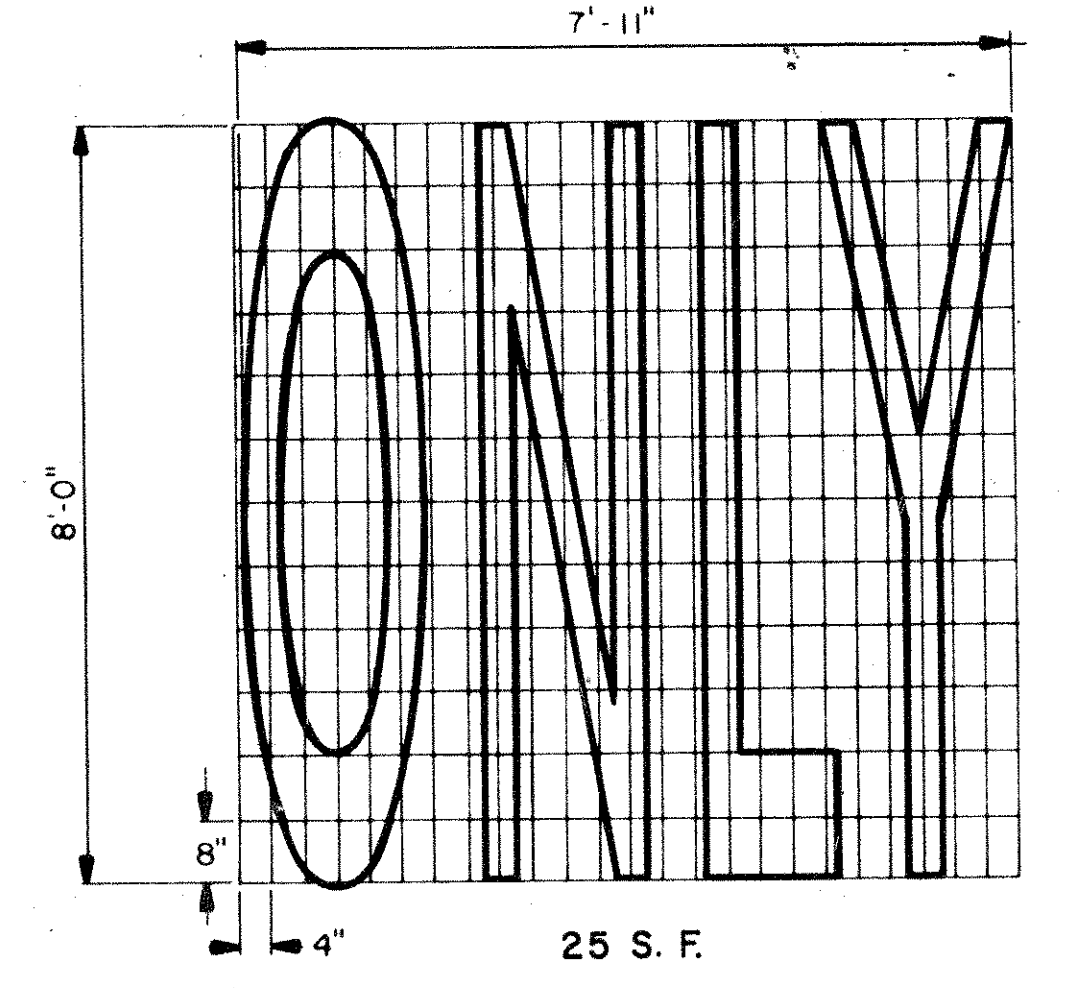

25 S.F.

**PAVEMENT LEGEND DETAILS
(WHITE)**

- NOTES:**
1. Stop Bars to be 12" unless otherwise noted on Plans.
 2. Stop Bars to be painted a minimum of 4' in advance of nearest edge of Crosswalk.
 3. In absence of Marked Crosswalk the Stop Bar shall be placed at the Desired Stopping Point, in no case more than 30' or less than 5' from the nearest edge of the intersection roadway and 90° to centerline of roadway.
 4. The Stop Bar shall ordinarily be placed in line with the Stop Sign. However, if the Stop Sign cannot be located exactly where vehicles are expected to stop, the Stop Bar should be placed at the Stopping Point.
 5. Stop bars (and centerline, when side street widths are 16' or more) to be painted on side streets within limits of Construction, unless otherwise indicated, or as directed by the Engineer.

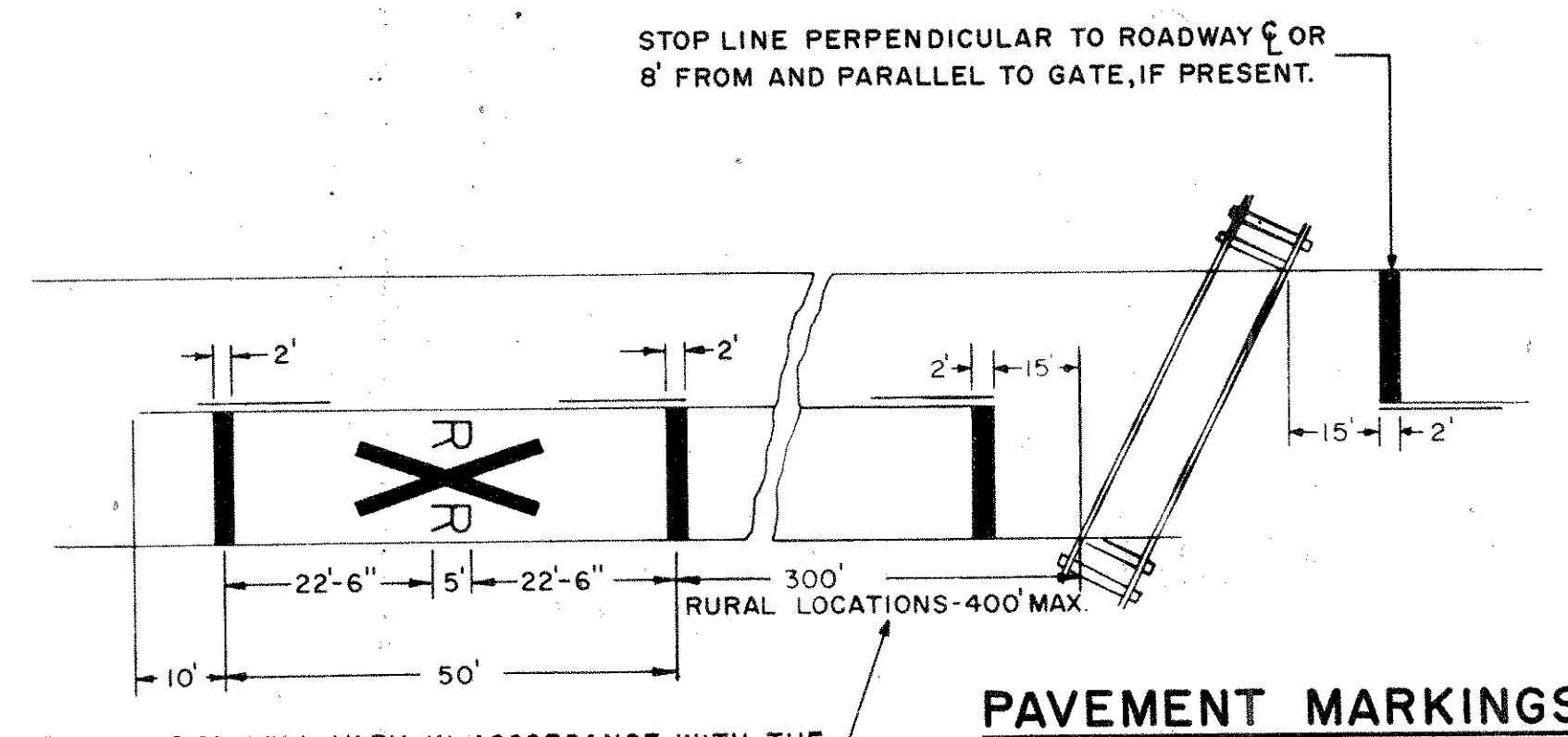

PAVEMENT MARKINGS AT RAILROAD GRADE CROSSINGS

(WHITE)

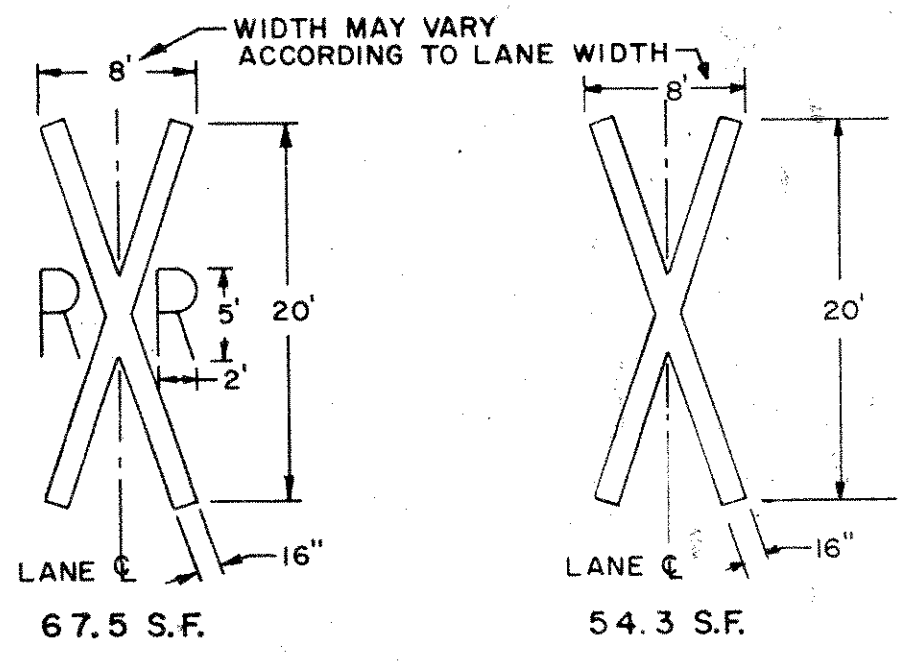

67.5 S.F.

54.3 S.F.

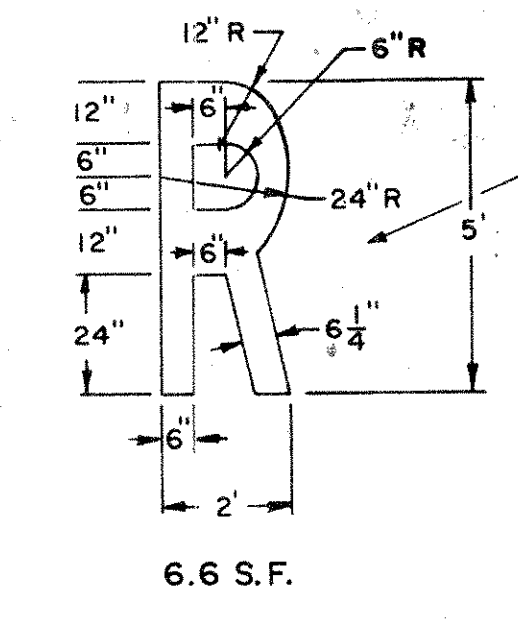

6.6 S.F.

DIMENSIONS SHALL BE ESSENTIALLY AS INDICATED. MAY VARY WITH ENGINEER'S APPROVAL

- NOTES:**
1. FOR PAVEMENT MARKINGS ON A CLIMBING LANE SEE DETAIL (H) ON THE DETAIL SHEET ENTITLED "TYPICAL PAVEMENT MARKINGS FOR DIVIDED HIGHWAYS".
 2. SQUARE FOOTAGE INDICATED IS APPROXIMATE.

REVISIONS		
NO.	DATE	DESCRIPTION
1	11-81	REVISED PAV. ARROWS TO MUTCD SPECS
2	1-82	END LINES OF HANDICAPPED PARKING STALLS REMOVED

**CONNECTICUT
DEPARTMENT OF TRANSPORTATION
BUREAU OF HIGHWAYS
DIVISION OF TRAFFIC**

**TYPICAL PAVEMENT MARKINGS
FOR TWO WAY HIGHWAYS**

SUBMITTED BY: *[Signature]* DATE: *[Date]*
 SUBMITTED BY: *[Signature]* DATE: *[Date]*
 APPROVED: *[Signature]* DATE: *[Date]*
 CHIEF OF TRAFFIC ENGINEERING

SCALE: NONE 25