

NOTICE FOR BIDS

Woodbridge Fire Department Garage
Woodbridge Finance Department
Bid #2020-03

Bid Opening Date: October 11, 2019
Bid Opening Time: 10:00 AM

Place: Woodbridge Town Hall
11 Meetinghouse Lane
Woodbridge, CT 06525

Please go to our website (www.woodbridgect.org) under the Government tab for bid details and instructions on obtaining complete bid documents.

The First Selectman or her/his designee may reject any and all bids if, in her/his opinion, it is in the best interest of the Town to do so. Minority/women-owned businesses are encouraged to submit a bid.

FIRE DEPARTMENT GARAGE - #2020-03

A. GENERAL INFORMATION

The Town of Woodbridge will entertain Proposals from qualified Contractors to furnish and install a 42’-6” x 42’-6” A Frame Style 1 ½ Story Garage behind the Woodbridge Fire Station located at 100 Center Road, Woodbridge. This project will consist of a specification build Garage on an existing foundation predicated on the minimum requirements included in the bid documents.

B. SITE

The garage will be located behind the Woodbridge fire station located at 100 Center Road in Woodbridge Connecticut. The garage will be used to store equipment for the Woodbridge Volunteer Fire Department. The site contains an existing foundation on which the garage will be located. The foundation is 42’-6” x 42’-6” and a plan is included for your reference.

C. PRE-BID WALKTHROUGH

A non-mandatory pre-bid walkthrough will take place at the site on October 4, 2019 at 8:30 am.

D. SCHEDULE

Release of RFP.....	September 25, 2019
Pre-bid walkthrough.....	October 4, 2019 at 8:30 am
Deadline for Questions	October 09, 2019 at 4:30 pm
Deadline for Proposals	October 11, 2019 at 10:00 am

E. CONTACT INFORMATION

For More Information, please visit our website at www.woodbridgect.org or contact:

Anthony Genovese
Administrative Officer / Finance Director
Email: agenovese@woodbridgect.org
Ph. 203-389-3482

All questions shall be in writing to the above email by October 9, 2019.

Town of Woodbridge Bid #2020-03

Technical Specifications

The Town of Woodbridge will entertain Proposals from qualified Contractors to furnish and install a 42'-6" x 42'-6" A Frame Style 1 ½ Story Garage behind the Woodbridge Fire Station located at 100 Center Road, Woodbridge. This project will consist of a specification build Garage on an existing foundation predicated on the following minimum requirements (refer to the attached for the desired design of the proposed Garage):

- 1) Provide two (2) complete sets of sealed engineered plans for the garage that must confirm & meet all local and State codes, without exception (note the foundation is already in place – include any and all work required to construct the proposed garage on this existing foundation)
- 2) 2" x 6" wall construction, 16" on center
- 3) 14 foot first floor wall height
- 4) 1" x 8" kiln dried vertical shiplap pine siding
- 5) Pine fascia and trim soffits
- 6) Tyvek building wrap
- 7) ½" Douglas Fir plywood sheathing on roof & walls
- 8) ¾" Douglas Fir T&G plywood on second floor
- 9) Upgraded clear span truss package (requiring NO interior columns)
- 10) 7 – 12 Cape style roof pitch
- 11) 16' x 42' Upstairs floor space with 8' peak ceiling height
- 12) 1' gable & eave overhang
- 13) Construction – Type stairs to second floor
- 14) 30 Year architectural shingles over felt paper to match existing roof
- 15) Full length ridge vent & soffit
- 16) Three (3) 10' x 10' Overhead Doors w/ glass
- 17) One (1) 3' x 6'-8" Thermatru Model 5262 Fiberglass insulated entry door w/ half glass
- 18) Six (6) 2'-6" x 4'-0" Anderson Series 400 Vinyl Insulated double hung windows
- 19) Sheetrock prep package (includes framing upstairs gable ends, ready for insulation & sheetrock)

Options Available

- 1) Upgrade to Hardie Plank Clapboard Siding with Azek Trim
- 2) 1-18' Faux Transom Dormer w/ 6 2' x 2' Anderson Awning Windows (Bronze)
- 3) Stain Structure with Semi Transparent Stain (Single Color)
- 4) Paint Structure with Solid Product (Single Color)

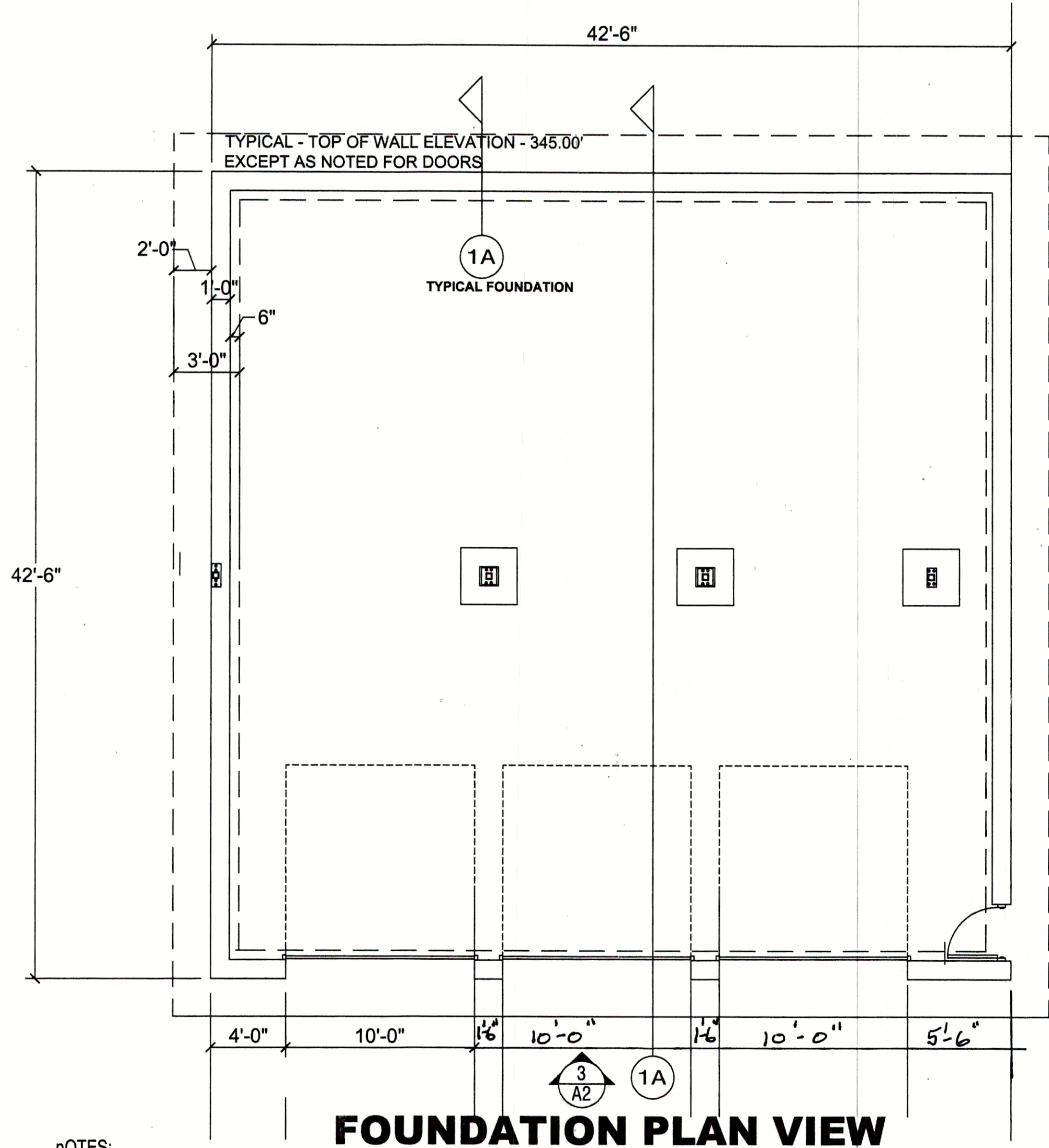

FOUNDATION PLAN VIEW

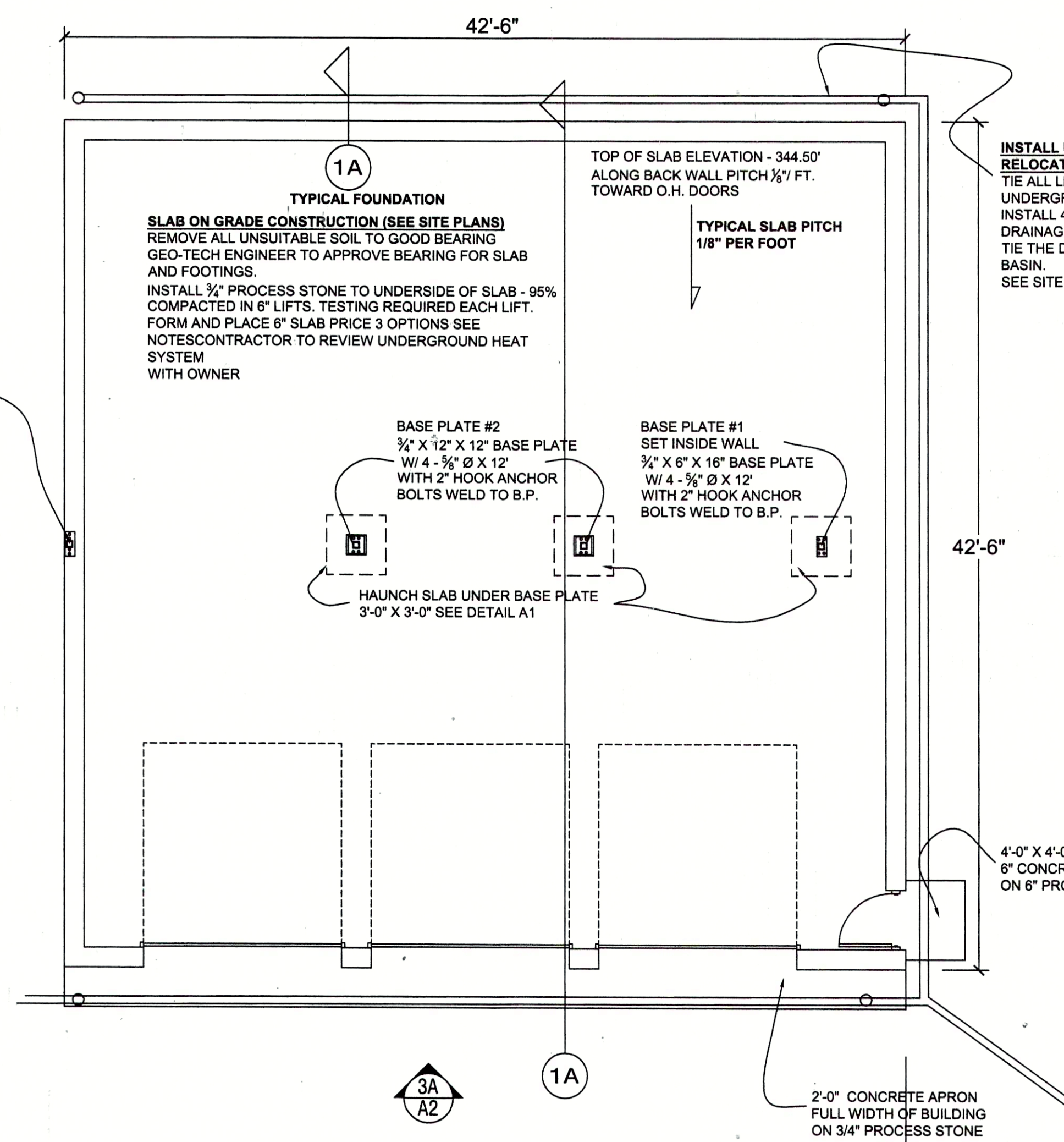

FIRST FLOOR SLAB ON GRADE PLAN

- NOTES:
- 1.) TOP OF FINISH FLOOR ELEVATION = 0.0', UNLESS OTHERWISE NOTED 1.) FLOOR CONSTRUCTION: OWNER TO DECIDE WHAT LOADING TO USE FOR SLAB FROM THE FOLLOWING OPTION
 - A.) GARAGE SLAB: SLAB DESIGN FOR 50 P.S.F. LOADING 6" CONCRETE SLAB F/C CONCRETE 4,000 PSI AND REINFORCED WITH 6X6-W2.9XW2.9 W.W.F. (SHEETS & CHAIRED). WITH 6" LAYER OF 3/4"(-) PROCESS STONE ON A 6 MILL VAPOR RETARDER ON CONTROL POROUS GRAVEL FILL, REFER TO TYPICAL DETAILS
 - B.) GARAGE SLAB: SLAB DESIGN FOR H2O LOADING - 8" CONCRETE SLAB F/C CONCRETE 4,000 PSI AND REINFORCED WITH 2 LAYERS - #6 @ 12" O.C. - EACH WAY. (CHAIRED). WITH 6" LAYER OF 3/4"(-) PROCESS STONE ON A 6 MILL VAPOR RETARDER ON CONTROL POROUS GRAVEL FILL, REFER TO TYPICAL DETAILS
 - C.) GARAGE SLAB: SLAB DESIGN FOR 125 P.S.F. LOADING - 6" CONCRETE SLAB F/C CONCRETE 4,000 PSI AND REINFORCED WITH 2 LAYERS - #3 @ 12" O.C. - EACH WAY. (CHAIRED). WITH 6" LAYER OF 3/4"(-) PROCESS STONE ON A 6 MILL VAPOR RETARDER ON CONTROL POROUS GRAVEL FILL, REFER TO TYPICAL DETAILS
 - 2.) SECOND FLOOR FLOOR SLAB:
 - A.) GARAGE SLAB: SLAB DESIGN FOR 125 P.S.F. LOADING - 6" CONCRETE SLAB F/C CONCRETE 4,000 PSI AND REINFORCED WITH 2 LAYERS - #3 @ 12" O.C. - EACH WAY. (CHAIRED). WITH 6" LAYER OF 3/4"(-) PROCESS STONE ON A 6 MILL VAPOR RETARDER ON CONTROL POROUS GRAVEL FILL, REFER TO TYPICAL DETAILS
- NOTE:
- 1.) CONTRACTOR TO REVIEW UNDERGROUND HEAT SYSTEM WITH OWNER
 - 2.) APPLY SINGLE COAT OF WR MEADOWS VO COM 20 CURING & SEALING AGENT OR EQUAL AFTER SLAB FINISH IS COMPLETE
 - 3.) ALL GRAVEL 95% COMPACTED.
 - 4.) PROVIDE THICKENED SLAB UNDER ALL 6" & GREATER METAL STUD WALLS AND/OR ANY CMU WALLS NOT SUPPORTED BY FOUNDATION WALL. REFER TO ARCH'L DRAWINGS FOR LOCATION OF WALLS.
 - 5.) FOR FOUNDATION DETAILS, REFER TO TYPICAL FOUNDATION DETAILS.
 - 6.) F/C CONCRETE = FOOTING & WALLS - 3000 PSI UNLESS NOTED. SLABS - 4000 PSI UNLESS NOTED
 - 7.) REINFORCING STEEL = GRADE 60

- CONTRACTOR NOTE:
- 1.) ALL FOOTINGS AND CONTROL FILL FOR THE SUPPORT OF THE CONCRETE SLAB ARE TO BE PLACED ON UNDISTURBED SOIL.
 - 1A.) A GEO-TECHNICAL ENGINEER SHALL CERTIFY THAT THE FOOTING BEARING SOIL SHALL SUPPORT THE ASSUME FOOTING BEARING PRESSURE OF 3,000 P.S.F.
 - 2.) THE CONTRACTOR SHALL BACKFILL THE INSIDE OF THE FOUNDATION WALLS TO BRING THE GRADE TO THE UNDERSIDE OF SLAB ON GRADE. THE CONTRACTOR SHALL USE 3/4" PROCESS CRUSH STONE THAT MEETS THE STATE OF CONNECTICUT D.O.T. SPECIFICATION 814A CURRENT EDITION. COMPACT THE CRUSH STONE TO 95% COMPACTIONS. EACH LIFT SHALL BE TESTED BY A TESTING LAB SELECTED BY THE OWNER. THE TESTING LAB WORK SHALL BE COORDINATED BY THE CONTRACTOR AND SHALL BE PAID FOR BY OWNER.
 - 3.) THE EXISTING WETLAND SOIL SHALL BE REMOVED AND STORED ON SITE. THE WETLAND SOIL SHALL BE USED TO BACK FILL OUTSIDE THE FOUNDATION THAT IS IN THE WETLAND AND ALL DISTURBED AREA IN THE WETLAND. THE WETLAND AREAS ARE TO BE RESTORED TO ORIGINAL CONDITIONS AND REPLANTED. SEE SITE PLANS FOR SCOPE OF WORK. SEE SITE PLANS

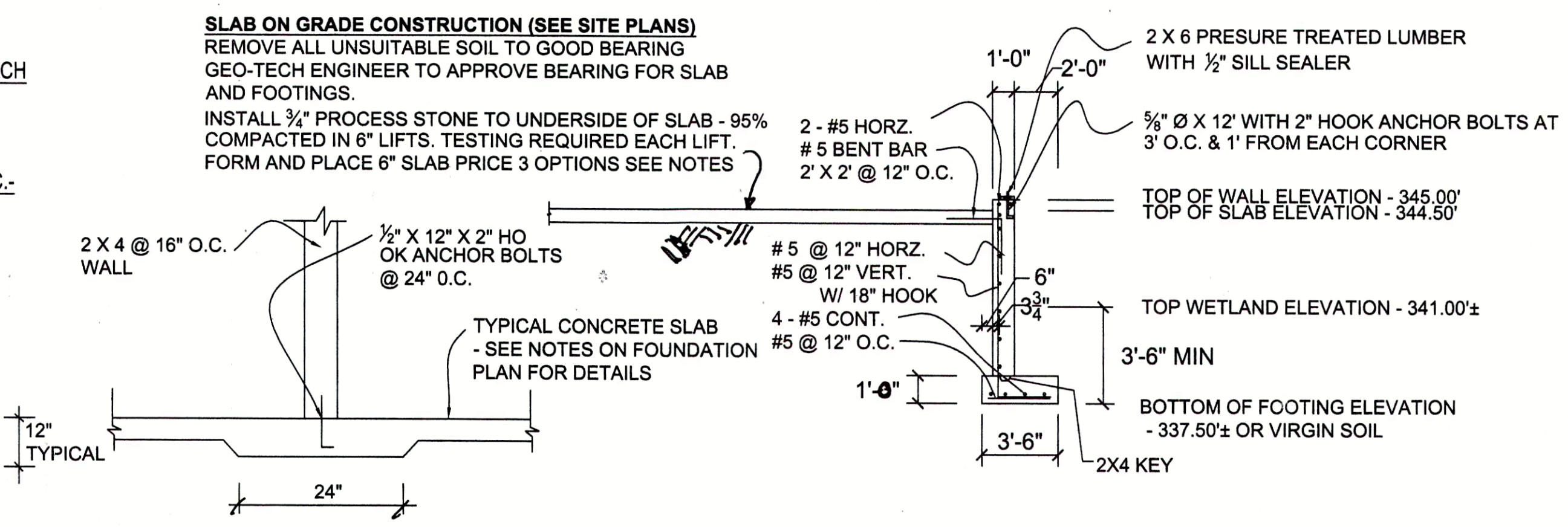

TYPICAL FOUNDATION DETAIL 1A

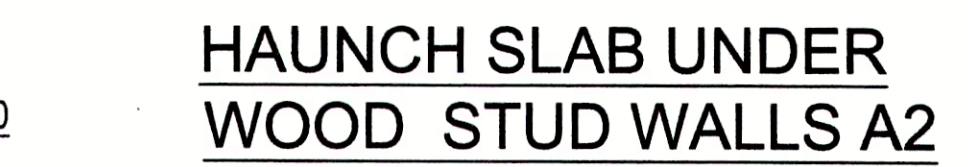

HAUNCH SLAB UNDER WOOD STUD WALLS A2

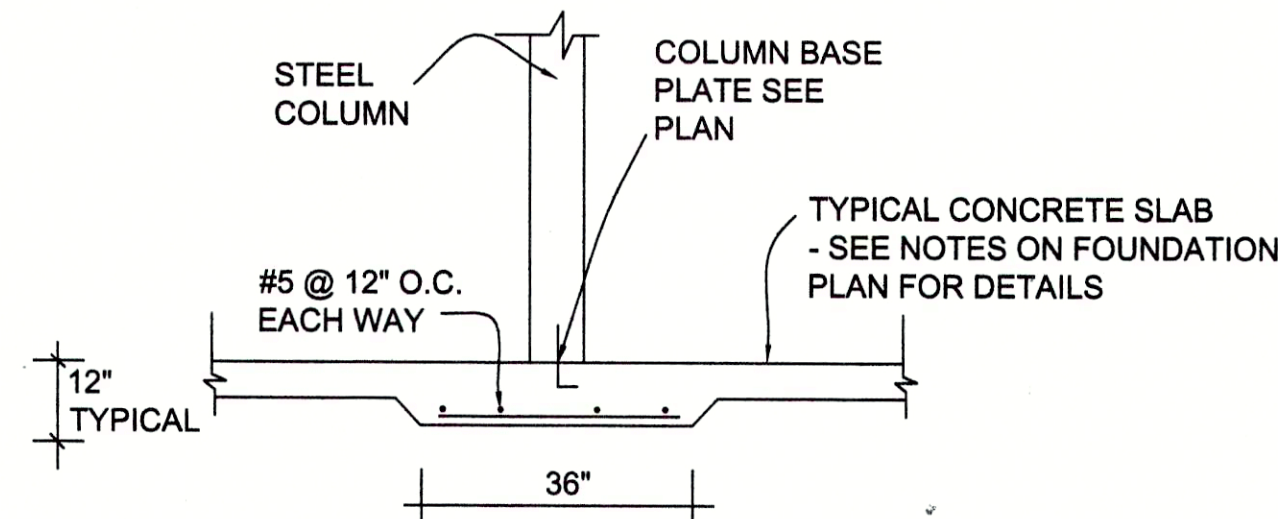

HAUNCH SLAB UNDER STEEL COLUMNS A1

General Notes

TOWN OF WOODBRIDGE
11 MEETINGHOUSE ROAD
WOODBRIDGE CT 06525

STORAGE BUILDING

FOUNDATION PLAN

FIRST FLOOR SLAB ON GRADE PLAN

TYPICAL FOUNDATION SECTION AND DETAILS

No.	Revision/Issue	Date

Firm Name and Address
JOSEPH A. RAIOLA P.E.
 CONSULTANT ENGINEER
 379 DERBY AVENUE
 WEST HAVEN CT 06516
 203-745-1158 or 641-2649

Project Name and Address
FIREHOUSE
 STORAGE BUILDING
 GABLE ROOF
 WOODBRIDGE, CT

Project 2010-100	Sheet
Date 10-02-10	A1
Scale 3/16" = 1'-0"	

new_garage_8_1_10.dwg

1/15/2004

GENERAL INSTRUCTIONS TO BIDDERS

The following instructions and specifications shall be observed by all bidders:

1. PROPOSAL COMPLIANCE

Bids shall be submitted on the enclosed forms. Incomplete forms may be cause for disqualification of the bid. Bids must be signed by the authorized representative/officer/agent of the bidder.

The Town of Woodbridge shall be the sole judge as to whether any bid complies with these specifications, and such a decision shall be final and conclusive. Bidders shall state any exceptions taken to the bid specifications.

2. BID RETURN ENVELOPE

All bids shall be submitted in sealed, opaque envelopes clearly labeled with the name of the bidder, his address, and the words "BID DOCUMENTS". Please clearly mark your envelope with the bid title and opening date to prevent opening of a sealed bid prior to the opening date. Proposals submitted in unmarked envelopes which are opened by the Town in its normal course of business will not be accepted. If time permits, the proposals will be returned to the bidder informing them that the proposal may be resubmitted in a sealed envelope properly marked as indicated above. The town will not be held responsible for those bids lost in the mail.

3. BID PROPOSAL/PRICE

Each bid must be submitted on the prescribed form and all blank spaces for bid prices must be filled in ink or typewritten in both words or figures. Bid prices shall include all labor, materials and equipment necessary to complete the work in accordance with the contract documents or these specifications and instructions. All prices must be NET, F.O.B. to the Town of Woodbridge, 11 Meetinghouse Lane, Woodbridge, Connecticut unless otherwise indicated. Bidders may quote on any, some or all items.

Negligence on the part of the bidder in preparing a bid confers no right of withdrawal or modification of a bid after such bid has been opened.

The Town of Woodbridge is exempt from the Connecticut sales tax, Federal excise taxes, and the provisions of the Federal Robinson-Patman Act. In addition, any taxes due by the trade contractor or Contractor shall not be passed on to Town as expense or cost.

4. WITHDRAWAL OF BIDS

Bids may be withdrawn personally or in writing by the bidder in time for delivery in the normal course of business prior to the time fixed for opening. Once bids are opened the prices shall remain firm for sixty (60) days after the bid opening.

5. RIGHT OF REJECTION

The Request for Proposal/bid does not necessarily contemplate an award based solely on price. The Board of Selectmen or its designee may reject or accept any and all bids in whole or in part or may waive any informality in bids received if, in its/his/her opinion, it is in the best interest of the Town to do so, for whatever reason.

6. METHOD OF AWARD—FACTORS

- A. Where more than one item is bid, the Town reserves the right to split the bid award individually or grouped if it in the Town's best interest to award base bid and alternate to different vendors for any reason.
- B. The start date and timeline may be a major factor considered in awarding a contract and may result in an award to a vendor other than the low bidder.
- C. In the event there is a discrepancy between the price written in words and in figures, the price written in words shall govern.

7. FAMILIARITY WITH LAWS, SITE CONDITIONS AND DOCUMENTS

Each bidder is required to be familiar and comply with the terms and conditions of the specifications and all other contract documents and with all federal, state, and local laws, ordinances or regulations which in any manner relate to the furnishing of the equipment, material or services in accordance with the contract.

The submission of a bid shall be construed as an assurance that the bidder has examined all the conditions of the bid documents and specifications, and the failure of the bidder to familiarize himself with conditions related to the specifications shall in no way relieve any bidder from any obligation in respect to this bid.

8. QUALIFICATIONS OF BIDDER

The Town may make such investigation as it deems necessary to determine the ability of the bidder to perform the work. The bidder shall furnish to the Town all such information for this purpose as the Town may request. The Town reserves the right to reject any bid if the evidence submitted by or discovered by investigation of a bidder fails to satisfy the Town that such bidder is qualified to carry out the obligations of the contract and to the work contemplated therein.

9. ERRORS, INTERPRETATIONS, AND ADDENDA

Should the bidder find any omissions, discrepancies or errors in the specifications or other contract documents or should the bidder be in doubt as to the meaning of the specifications or other contract documents, the bidder should immediately notify the Town Finance Director, who may correct, amend or clarify such documents by a written interpretation or addendum. No oral interpretation shall be made to any bidder and no oral statement of the Town or any agent or representative of the Town shall be effective to modify any of the provisions of the contract documents. The Town of Woodbridge shall have the right to request clarifications of bids submitted and hold public hearings for the consideration of the merits of any or all bidders.

10. SUBSTITUTION FOR NAMED BRANDS OR SUBCONTRACTING

Should brand name items appear in these specifications, before bidding on any item considered equal to or better than a named item, the bidder shall get written approval from the Finance Director for the substitution. The bidder shall not subcontract the work under this project without the written approval of the Finance Director.

11. GUARANTEE

All equipment and materials including all parts and assemblies, if applicable, shall be guaranteed against defects in material and workmanship and shall be in accordance with specifications and adequate for its intended use. Where it is required for the vendor to repair, replace or to modify, alter, add or remove hardware, parts, components or related accessories for the purpose of insuring proper appearance, performance or operation, the same shall be done as required by the vendor until such time as acceptable performance, operation or appearance has been established. Problems that may occur shall be corrected consistent with the guarantee. The vendor shall attend to and remedy such items in a reasonable and timely manner. Appropriate logs, schedules, and reports shall be maintained by the vendor to document these items and the action taken. Warranty information, catalogues of parts, and/or instructions of use shall be provided with the bid form when appropriate; otherwise, the same shall be provided upon delivery. All warranties shall be assignable to any customer of the Town of Woodbridge or agent thereof intended to benefit from such services. These warranties shall be in addition to any remedies provided by applicable law. Bidder warrants that all goods and services furnished

hereunder shall be designed, constructed and performed so as to comply with the Williams-Steiger Occupational Safety and Health Act of 1970, as amended from time to time, and the rules, regulations and standards issued thereunder by any applicable governmental authority which as of the date of performance will apply to the goods and services furnished hereunder.

12. HAZARDOUS WASTE

In the event that equipment or materials are the subject of this bid and they involve the handling of hazardous waste and associated insurance coverages are not identified elsewhere in the bid documents, the bidder's insurance policy must provide Environmental Impairment Liability. The bidder warrants that it understands the currently known and suspected hazards to persons, property and the environment by the transport, treatment, and disposal of hazardous waste. The bidder warrants that it will perform all services hereunder in a safe, efficient and lawful manner using industry-accepted practices and in full compliance with all applicable Connecticut and federal laws and regulations.

13. INDEMNIFICATION

The bidder shall at all times indemnify and hold harmless the Town of Woodbridge and its officers, agents and employees on account of and from any and all claims, damages, losses, judgments, workers' compensation payments, litigation expenses and legal counsel fees arising out of injuries to persons (including death) or damage to property alleged to have been sustained by (a) officers, agents and employees of the Town of Woodbridge or (b) the bidder, his subcontractors or material men or (c) any other person, which injuries are alleged to have occurred on or near the work or to have been caused in whole or in part by the acts, omissions or neglect of the bidder or his subcontractor or material men or by reasons of his or their use of faulty, defective or unsuitable materials, tools, or equipment of defective design in constructing or performing under this bid. The existence of insurance shall in no way limit the scope of this indemnification. The bidder shall reimburse the Town of Woodbridge for damage to property of the Town of Woodbridge caused by the bidder, or his employees, agents, subcontractors or material men or by faulty, defective or unsuitable material or equipment used by him or them. Bidder agrees that he will indemnify and hold the Town harmless for all claims growing out of the lawful demands of subcontractors, laborers, suppliers and assignees. Bidder further agrees to assume and pay for the defense of all such claims, demands, suits, proceedings and litigation. The provisions of this paragraph shall survive the expiration or early termination of this agreement.

14. QUANTITIES

The quantities as listed are estimates. The Town is in no way obligated to purchase any set amount at any time, but will purchase as needs dictate. The Town reserves the right to increase or decrease the quantity of each bid item at the same bid price stated on the bid form.

15. EVIDENCE OF ORDER

If notified of the acceptance of this proposal and the proposal involves ordering equipment or materials, the bidder agrees to submit evidence of having ordered the equipment and/or material within five (5) days of the “NOTICE TO PROCEED”.

16. RIGHT TO TERMINATE CONTRACT

In the event that any of the provisions of this contract are violated by the bidder or any of his subcontractors, the Town may serve written notice upon the contractor of its intention to terminate the contract. Such notices shall contain the reasons for such intention to terminate the contract and the contract shall cease and terminate within five (5) days, unless within five (5) days after the delivery of such notice upon the bidder, such violation or delay shall cease and mutually acceptable arrangements for correction are made. In the event of any such termination, the Town shall deliver notice of such termination to bidder.

The Town of Woodbridge reserves the right to cancel outstanding orders awarded against this bid after reasonable time for delivery has passed. In addition, in the event of any such cancellation, the Town of Woodbridge shall have the right to contract with the next most qualified bidder hereunder, as determined by the Town of Woodbridge, if it deems it in the best interest of the Town of Woodbridge. Notwithstanding the foregoing, the Town shall not be held to a basis of the lowest prices for which the completion of the work or the supplying of equipment or any part thereof might have been accomplished, but it shall charge the defaulting bidder and the defaulting bidder shall be liable for all sums actually paid or expenses actually incurred in effecting prompt performance hereunder. In the event the Town of Woodbridge incurs any loss, cost or expense on account of such termination or cancellation (including, without limitation, additional cost of the next most qualified bid or performing under the contract and attorneys' fees), the bidder as to whom or which the contract shall have been terminated or cancelled shall be liable to the Town of Woodbridge for such loss, cost, or expense.

17. DELIVERY

Delivery of items or commencement of project shall be within thirty (30) days of purchase order issuance or specified date scheduled in this document. The Town may establish blanket purchase orders under these specifications and require delivery on a monthly basis.

18. RISK OF LOSS

Bidders agree to bear the risk of loss, injury, or destruction of goods and material ordered herein which occurs prior to acceptance. Such loss, injury or destruction shall not release the bidder from any obligation under this bid. Delivery shall be F.O.B.

19. PAYMENT

Invoices shall be furnished to the Woodbridge Finance Director for verification and approval of the amount due the successful bidder. Final payment shall not be made until final acceptance by the Town of Woodbridge of all vehicles, equipment, materials or services. Payment shall be made within 30 days after approval and acceptance. Terms and conditions other than those stated above must be stated on bid. If a successful bidder is in default hereunder and/or the Town of Woodbridge is of the opinion that a meritorious claim exists or will exist against such bidder of the Town arising out of the negligence of such bidder, then the Town may withhold payment of any amount otherwise due and payable hereunder. Any amount so withheld may be retained by the Town for such period as it may deem advisable to protect the Town against any loss and may, after written notice to such bidder, be applied in satisfaction of any claim herein described. This provision is intended solely for the benefit of the Town and no person shall have any right against the Town or claim against the Town by reason of the Town's failure or refusal to withhold monies. This provision is not intended to limit or in any way prejudice any other right of the Town and no interest shall be payable by the Town on any amounts withheld under this provision.

20. EQUAL OPPORTUNITY—AFFIRMATIVE ACTION

Each bidder with ten (10) or more employees shall complete the Certificate of Bidder which is included as part of these specifications. Bidders with less than ten (10) employees should indicate this on the Certification and return it with their bid.

A signature on the form certifies that the bidder does not discriminate on the basis of race, color, sex, national origin, age or disability.

21. APPLICABLE LAW

This agreement shall be construed in accordance with the laws of the state of Connecticut and any action at law in connection herewith shall be brought in Connecticut state courts.

22. REQUIRED PROVISIONS

Each and every provision and clause required by law to be inserted in this agreement shall be deemed to be inserted herein and the agreement shall be read and enforced as

though such provisions and clauses were included herein. If, through mistake or otherwise, any such provision is not inserted or is not correctly inserted, then, upon the written consent of the parties, this agreement shall forthwith be physically amended to make such insertion.

23. GENERAL

A successful bidder may be required to furnish a performance bond acceptable to Town Counsel.

Any unit furnished as a result of this bid is to be a new and unused model currently in production. Accessories necessary for its proper functioning on delivery are assumed to be included in the quote even though not necessarily mentioned in the specifications. All assemblies, sub-assemblies and component parts for all units specified are to be standard and interchangeable except where noted.

The award of any contract hereunder is subject to the following conditions and contingencies:

- a) The approval of such governmental agencies as may be required by law;
- b) The appropriation of adequate funds by the proper agencies or governmental bodies;
- c) If the bidder is a corporation or other legal business entity, it must have a current license to do business in the state of Connecticut that is on file with the Connecticut Secretary of the State or it must be organized and in good standing under the laws of the State of Connecticut.

24. CONFLICTING PROVISIONS

If any of the provisions hereunder conflict with the provisions of any specifications attached hereto or issued in connection herewith, the contractual provisions of these instructions shall control. Notwithstanding the foregoing, the Town of Woodbridge reserves the right to issue written clarification regarding resolution of any conflicting provisions, in which event such written clarification shall control.

25. INSURANCE REQUIREMENTS

The bidder shall carry at its expense and provide evidence of insurance coverage listed below to protect itself and the Town of Woodbridge from and against liability, loss, damage, expense, cost (including without limitation to litigation and court costs and attorneys' fees) out of or in connection with the performance of any work performed in accordance with the specifications or any related documents, whether such work is performed by the bidder or any subcontractor or by anyone directly or indirectly employed by any of them, or by anyone for whose acts any of them may be liable. Coverage must be written with insurance companies licensed in the State of Connecticut and approved by the Town of Woodbridge. The insurance company writing coverage must have at least an A- rating by Best & Company. All policies

shall provide a thirty (30) day advance notice of cancellation to the Town of Woodbridge.

1. **Workers Compensation:**

Coverage A:	Statutory
Coverage B:	
Employers Liability:	
Bodily injury by accident	\$100,000 per person
Bodily injury by disease	\$100,000 per person
Bodily injury by disease	\$500,000 aggregate

All states and voluntary compensation endorsements

2. **Commercial General Liability**

Limits of Liability:	\$1,000,000 each occurrence
	\$2,000,000 general aggregate
	\$2,000,000 products/completed operations aggregate
3. **Auto Liability**

Limits of Liability:	\$1,000,000 each accident
----------------------	---------------------------
4. **Excess (Umbrella) Liability:**

The requirement that an Umbrella Policy be provided will depend on a case-by-case evaluation. Your exposure to catastrophic loss arising from the work or service being performed will determine the limit required.

Note: Special policy endorsement or additional coverages may also be required based on the special nature of the work of service being required (Professional Liability, E&O, D&O, Sexual Abuse and Molestation coverage and Bonds).

Coverage:

Town of Woodbridge to be named as additional Insured on a primary and non-contributory basis to all policies, except Workers Compensation. All policies should also include a Waiver of Subrogation.

Certificates of insurance shall be presented to the Finance Director for approval before the successful bidder, its agents and/or employees commence any work whatsoever pursuant to the contract.

Certification of Bidder

Concerning Equal Employment Opportunities and/or
Affirmative Action Policy

I/we, the bidder, certify that:

- 1) I/we comply with the equal opportunity clause as set forth in the Connecticut state law.
- 2) I/we do not maintain segregated facilities;
- 3. I/we have filed all required employer's information reports;
- 4. I/we list job openings with federal and state employment services;
- 5. I/we are in compliance with the American with Disabilities Act;
- 6. I/we (check one):

_____ Have an affirmative action program, or

_____ Employ ten or fewer people

Bidder-Company Name

Name

Title

Signature

Date

NON COLLUSION AFFIDAVIT

This Affidavit must be completed, notarized and attached to your Bid Proposal. Failure to do so will result in the rejection of your Bid. A separate Affidavit must be submitted by each principal of a Joint Venture.

City/Town

Woodbridge

Description of Project: _____

I, _____, acting in behalf of _____
(Name of Party Signing Affidavit) (person, firm, association, corporation, or organization)

of which I am _____, submitting a bid/request for proposal for the above project, certify and affirm that
(Title of Person)

the _____ has neither directly or indirectly entered into any agreements,
(person, firm, association, corporation, or organization)

participated in any collusion or otherwise taken any action in restraint of free competitive bidding in connection with such bid.
False statements made herein may be the subject of criminal prosecution.

Name of Corporation or Firm

Signature and Title of Official Making the Affidavit

Subscribed and sworn to before me this _____ day of _____, 20_____.

Notary Public/Commission of the Superior Court
My Commission Expires: _____

CERTIFICATE OF CORPORATION

I, _____, certify that I am the _____
of the Corporation named in the foregoing instrument: That I have been duly authorized to affix the seal of the Corporation to such papers as require the seal; that _____, who signed said instrument on behalf of the Corporation, was then _____ of said Corporation; that said instrument was duly signed for and in behalf of said Corporation by authority of its governing body and is within the scope of its corporate powers.

(Corporate Seal)

Signature of Person Certifying

DELINQUENT TAX AFFIDAVIT

This Affidavit must be completed, notarized and attached to your Bid Proposal. Failure to do so may result in the rejection of your Bid.

City/Town

Woodbridge

Description of Project:

I, _____, acting on behalf of _____ of which I
(Name of Party Signing Affidavit) (person, firm, association, corporation, or organization)

am _____, submitting a bid/request for proposal for the above project, certify and affirm the following:
(Title of Person)

1. the undersigned, certifies that neither the above-captioned entity, nor individually, owes delinquent taxes or any other financial obligation to the Town;

2. the undersigned has (check one)

_____ (a) filed a list of taxable personal property with the assessor for the most recent grand list as required by state statute, or

_____ (b) is not required to file such list

To the best of my knowledge and belief no affiliated entity of the undersigned, either directly or through a lease agreement, owes taxes to the Town;

To the best of my knowledge and belief the following are the names of all persons who are owners or officers of the undersigned.

(attach additional sheets if necessary)

False statements made herein may be the subject of criminal prosecution.

Name of Corporation or Firm

Signature and Title of Official Making the Affidavit

Subscribed and sworn to before me this _____ day of _____, 20_____.

Notary Public/Commission of the Superior Court

My Commission Expires: _____

CERTIFICATE OF CORPORATION

I, _____, certify that I am the _____ of the Corporation named in the foregoing instrument: That I have been duly authorized to affix the seal of the Corporation to such papers as require the seal; that _____, who signed said instrument on behalf of the Corporation, was then _____ of said Corporation; that said instrument was duly signed for and in behalf of said Corporation by authority of its governing body and is within the scope of its corporate powers.

(Corporate Seal)

Signature of Person Certifying

**TOWN OF WOODBRIDGE, CONNECTICUT
GENERAL CONDITIONS & BID SPECIFICATONS**

REFERENCE SHEET LISTING

Please provide a minimum of three (3) municipal references including community, contact person and telephone number.

