



**BID #2019-45  
ROOF REPLACEMENT  
STRATFORD ACADEMY – JOHNSON HOUSE**

TOWN OF STRATFORD  
PURCHASING DEPARTMENT  
2725 MAIN STREET  
STRATFORD, CT 06615

Date Submitted \_\_\_\_\_, 2019.

SEALED submissions are subject to the standard instructions set forth on the attached sheets. Any modifications must be specifically accepted by the Town of Stratford.

Bidder:

\_\_\_\_\_  
Doing Business As (Trade Name)

\_\_\_\_\_  
Address

Released: *Tuesday, June 4, 2019*

\_\_\_\_\_  
Town / State / Zip

*Phillip Ryan, Purchasing Agent*

\_\_\_\_\_  
Title (Mr /Ms)

\_\_\_\_\_  
Signature

\_\_\_\_\_  
Telephone

\_\_\_\_\_  
E-mail

Sealed bids will be received by the Purchasing Department at the office of the Purchasing Agent, 2725 Main Street, Room 202, Stratford, Connecticut 06615, up to:

**11:00AM, Tuesday, June 18, 2019**

NOTE:

1. Bidders are to complete all requested data in the upper right corner of this page and must return this page with their bid proposal.
2. No bid shall be accepted from, or contracts awarded to, any person/company who is in arrears to the Town of Stratford upon debt, or contract or who has been within the prior five (5) years, a defaulter as surety or otherwise upon obligations to the Town of Stratford.
3. Submissions are to be submitted in a sealed envelope and clearly marked **"BID #2019-45"** on the outside of the envelope, including all outer packaging, such as, DHL, FedEx, UPS, etc.

## PROJECT TEAM

### Architect / Project Manager:

# SNYDER ARCHITECTS, LLC

Architecture . Planning . Construction Management

Trumbull, CT      203-243-3346  
info@snyderarchitects.com

### Roofing Consultant:



M A CAPUTO | ASSOCIATES, LLC  
ROOF & BUILDING ENVELOPE CONSULTANTS

New Haven, CT  
203-469-3216

### Environmental Consultant

# AMC

## ENVIRONMENTAL, LLC

P.O. Box 423  
Stratford, CT  
203-378-5020

<b>Roof Replacement:</b>		
<b>Stratford Academy - Johnson House</b>		
5/4/2019		
<b>Table of Contents</b>		
<b>SECTION</b>	<b>SECTION NAME</b>	<b>DATE</b>
	Table of Contents	5/4/2019
	Invitation to Bid	5/4/2019
	Information for Bidders	5/4/2019
	CHRO Contract Compliance Regulations Notification to Bidders	6/4/2019
	Bid Form	5/4/2019
	Statement of Qualifications (AIA A305)	3/8/2019
	A310 Bid Bond	3/8/2019
	A312a Performance Bond	3/8/2019
	A312b Payment Bond	3/8/2019
	Wage Rates ( <a href="#">Applicable if project is over \$100,000</a> )	3/8/2019
	Section 31-53b - Construction Safety and Health Course	3/8/2019
	10-Hour OSHA Construction Safety and Health Course	3/8/2019
	CT General Statute 31-55a	3/8/2019
	Contractors Wage Certification Form	3/8/2019
	Payroll Certification Form	3/8/2019
	Occupational Classification Bulletin	3/8/2019
	CT DOL Wage and Workplace Standards Footnotes	3/8/2019
	Non-Collusion Affidavit	3/8/2019
	AIA A101: Agreement Between Owner and Contractor	3/8/2019
	AIA A201: General Conditions of the Contract for Construction	3/8/2019
	Supplementary Conditions	3/8/2019
	Insurance Procedure	3/8/2019
	<b>DIVISION 1 - GENERAL REQUIREMENTS</b>	
01000	Asbestos Testing Results Letter (AMC Environmental)	12/17/2018
01009	Milestone Schedule	5/4/2019
01100	Summary of Work	3/8/2019
01250	Regulatory Requirements	3/8/2019
01310	Project Management and Coordination	3/8/2019
01330	Submittal Procedures	3/8/2019
01400	Quality Requirements	3/8/2019
01600	Product Requirements	3/8/2019
	Product Substitution Form	3/8/2019
01770	Closeout Closeout	3/8/2019
	<b>DIVISION 4 - MASONRY</b>	
04550	Concrete Repairs	3/8/2019
04552	Masonry Restoration	3/8/2019
	<b>DIVISION 5 - METALS</b>	
05310	Steel Decking Inspection, Fastening, and Repair	3/8/2019
	<b>DIVISION 7 - THERMAL AND MOISTURE PROTECTION</b>	
07015	Preparation for Re-Roofing	3/8/2019
07355	Fully Adhered Thermoplastic Roof Covering	3/8/2019
07621	Thermoplastic Roofing Related Sheet Metal	3/8/2019
	<b>DRAWINGS (Formatted 24" x36")</b>	
T-101	Title Sheet	5/4/2019
A-101	Roof Plan	5/4/2019
A-201	Roof Details	5/4/2019



## INVITATION TO BID

The Town of Stratford (Town) and on behalf of its Board of Education (BOE) is seeking competitive bids from qualified contractors to perform **Roof Replacement at Stratford Academy – Johnson House, 719 Birdseye Street, Stratford.**

### PRE-BID MEETING

A site meeting will commence at **Stratford Academy – Johnson House, 719 Birdseye Street, Stratford** at **3:30** on **Friday, June 7, 2019** for prospective bidders to scope the conditions.

- While the meeting is non-mandatory, prospective bidders are strongly encouraged to attend and will be required to sign-in at commencement of the meeting. The sign-in sheet will be posted on the Purchasing Department website as below. Copies will not be made available at the meeting, nor will they be faxed out.
- All requests for information will be answered in writing as specified below under RFI / Addenda.

### REQUESTS FOR INFORMATION (RFI) / ADDENDA

Direct requests in writing to: Town of Stratford, Purchasing Department  
Attention: Phillip Ryan, Purchasing Agent  
2725 Main Street, Stratford, CT 06615  
E-mail: [PRyan@townofstratford.com](mailto:PRyan@townofstratford.com)

NOTE: Written requests for information will not be accepted after **12:00PM on Thursday, June 13, 2019.**

Response will be in the form of an addendum that will be posted periodically but no later than **Friday, June 14, 2019** at the close of business to the Purchasing Department website: [www.townofstratford.com/purchase](http://www.townofstratford.com/purchase)

It is the responsibility of each bidder to retrieve addenda from the website. Any contact about this bid between a Bidder and any other Town official and/or department manager and/or Town of Stratford employee, other than as set forth above, may be grounds for disqualification of that Bidder. No questions or clarifications shall be answered by phone, in person or in any other manner than specified above. Addenda will not be mailed, e-mailed or faxed out.

### CHECKLIST

The following must be submitted with proposal:

- Cover page, completed and signed.
- Bid Form
  - Addenda acknowledged on Bid Form, or submitted if requested.
- Bid Bond.
- Insurance Procedure
- Non-Collusion Affidavit
- AIA Document A305 – Contractor's Qualification Statement
- List of 5 (minimum) equivalent projects completed within the last 3-years.  
Include project and reference contact information for each.
- List of all subcontractors identifying each trade, hourly rates, location, and Tax ID number.
- Identify any exceptions that may apply. These must be itemized and attached to the proposal form.
- Contractor Prequalification Statement. **If contract exceeds \$500,000.00.**
- Update Bid Statement. **If contract exceeds \$500,000.00.**
- CHRO Bidder Contract Compliance Monitoring Report. **No exceptions.**

The Bidder hereby certifies that any and all defects, errors, inconsistencies or omissions of which he/she is aware, either directly or by notification from any material supplier found in the Contract Documents are listed herewith in this Bid Form.

Name \_\_\_\_\_ Title \_\_\_\_\_ Signature \_\_\_\_\_ Date \_\_\_\_\_

**COMPLETED PROJECTS / REFERENCES:**

Contractor required to have completed a minimum of 5 equivalent projects completed within the last 3-years. Provide project information and contact information below or attached Projects Sheet.

**PROJECT #1:**

Project		Contract Price	Completion Date
_____		_____	_____
Owner / Architect	Contact Person	Phone	E-mail
_____	_____	_____	_____
Description of the Work			
_____			

**PROJECT #2:**

Project		Contract Price	Completion Date
_____		_____	_____
Owner / Architect	Contact Person	Phone	E-mail
_____	_____	_____	_____
Description of the Work			
_____			

**PROJECT #3:**

Project		Contract Price	Completion Date
_____		_____	_____
Owner / Architect	Contact Person	Phone	E-mail
_____	_____	_____	_____
Description of the Work			
_____			

**PROJECT #4:**

Project		Contract Price	Completion Date
_____		_____	_____
Owner / Architect	Contact Person	Phone	E-mail
_____	_____	_____	_____
Description of the Work			
_____			

**PROJECT #5:**

Project		Contract Price	Completion Date
_____		_____	_____
Owner / Architect	Contact Person	Phone	E-mail
_____	_____	_____	_____
Description of the Work			
_____			

This page must be fully completed and submitted with your proposal, including accurate contact names and contact details. Prospective bidders may opt to submit own formatted reference sheets with complete project details and contact information.

**SUBCONTRACTORS**

Provide subcontractor details if any are to be employed as part of this contract, including labor rates:

**SUBCONTRACTOR #1:**

Name of Company \_\_\_\_\_ Fed ID # \_\_\_\_\_  
Contact Person \_\_\_\_\_ Title \_\_\_\_\_  
Company Address \_\_\_\_\_ Phone \_\_\_\_\_  
Trade \_\_\_\_\_ E-mail \_\_\_\_\_  
Rates: Supervisor \$ \_\_\_\_\_/hr Foreman \$ \_\_\_\_\_/hr Journeyman \$ \_\_\_\_\_/hr Apprentice \$ \_\_\_\_\_/hr

**SUBCONTRACTOR #2:**

Name of Company \_\_\_\_\_ Fed ID # \_\_\_\_\_  
Contact Person \_\_\_\_\_ Title \_\_\_\_\_  
Company Address \_\_\_\_\_ Phone \_\_\_\_\_  
Trade \_\_\_\_\_ E-mail \_\_\_\_\_  
Rates: Supervisor \$ \_\_\_\_\_/hr Foreman \$ \_\_\_\_\_/hr Journeyman \$ \_\_\_\_\_/hr Apprentice \$ \_\_\_\_\_/hr

**SUBCONTRACTOR #3:**

Name of Company \_\_\_\_\_ Fed ID # \_\_\_\_\_  
Contact Person \_\_\_\_\_ Title \_\_\_\_\_  
Company Address \_\_\_\_\_ Phone \_\_\_\_\_  
Trade \_\_\_\_\_ E-mail \_\_\_\_\_  
Rates: Supervisor \$ \_\_\_\_\_/hr Foreman \$ \_\_\_\_\_/hr Journeyman \$ \_\_\_\_\_/hr Apprentice \$ \_\_\_\_\_/hr

**SUBCONTRACTOR #4:**

Name of Company \_\_\_\_\_ Fed ID # \_\_\_\_\_  
Contact Person \_\_\_\_\_ Title \_\_\_\_\_  
Company Address \_\_\_\_\_ Phone \_\_\_\_\_  
Trade \_\_\_\_\_ E-mail \_\_\_\_\_  
Rates: Supervisor \$ \_\_\_\_\_/hr Foreman \$ \_\_\_\_\_/hr Journeyman \$ \_\_\_\_\_/hr Apprentice \$ \_\_\_\_\_/hr

**NOTE: All sub-contractors are subject to approval by the Town of Stratford and are required to provide Fed ID #.**





**PURCHASING DEPARTMENT  
TOWN OF STRATFORD  
INSTRUCTIONS FOR BIDDERS  
TERMS AND CONDITIONS OF BID**

**BID PROPOSALS**

Bid proposals are to be submitted in a sealed envelope and clearly marked on the outside **"BID #2019-45"** including all outer packaging such as DHL, FedEx, UPS, etc. All prices and notations must be printed in ink or typewritten. No erasures are permitted. Bid proposals are to be in the office of the Purchasing Department, Town Hall, 2725 Main Street, Room 202, Stratford, Connecticut, prior to date and time specified, at which time they will be publicly opened.

**RIGHT TO ACCEPT / REJECT**

AFTER REVIEW OF ALL FACTORS, TERMS AND CONDITIONS, INCLUDING PRICE, THE TOWN OF STRATFORD RESERVES THE RIGHT TO REJECT ANY AND ALL BIDS, OR ANY PART THEREOF, OR WAIVE DEFECTS IN SAME, OR ACCEPT ANY PROPOSAL DEEMED TO BE IN THE BEST INTEREST OF THE TOWN OF STRATFORD.

**POWER OF REJECTION**

The Mayor shall have the power to reject all bids and to advertise again.

**QUESTIONS**

Questions concerning conditions, bidding guidelines and specifications should only be directed in writing to:

**Mr. Phillip Ryan, Purchasing Agent:** [PRyan@townofstratford.com](mailto:PRyan@townofstratford.com)

Inquiries must reference date of bid opening, requisition or contract number, and must be received no later than as indicated in the bid documents prior to date of bid opening. Failure to comply with these conditions will result in the bidder waiving the right to dispute the bid specifications and conditions.

**PRICES**

Prices quoted must be firm, for acceptance by the Town of Stratford, for a period of ninety (90) days. Prices shall include all applicable duties. Bidders shall be required to deliver awarded items at prices quoted in their original bid.

**F.O.B. DESTINATION**

Prices quoted shall be net, delivered to destination. Bids quoting other than F.O.B. Destination may be rejected.

**BID BOND**

The BID BOND furnished, as bid security, must be duly executed by the bidder as principal. It must be in the amount equal to five percent (5%) of the total estimated bid, as guarantee that, in case the contract is awarded to the bidder, the bidder will, within ten days thereafter, execute such contract and furnish a Performance Bond and Payment Bond.

Small businesses may elect to obtain an irrevocable letter of credit or cashier's check in lieu of the Bid Bond. Such surety must also be in an amount equal to at least five percent (5%) of the total estimated bid.

All bid bonds shall be written by a surety company or companies licensed in the State of Connecticut, and shall have at least an A-VII policy holders rating, as reported by A.M. Best Rating Services, or otherwise deemed acceptable by the Town. The Town always reserves the right to reject surety companies, if an approved surety bond cannot be provided, the bidder shall be deemed non-responsive.

A complete list of certified surety companies can be accessed on the U.S. Government Department of Treasury website: [https://www.fiscal.treasury.gov/fsreports/ref/suretyBnd/c570\\_a-z.htm](https://www.fiscal.treasury.gov/fsreports/ref/suretyBnd/c570_a-z.htm)

NOTE: Failure to provide a Bid Bond or equivalent security is not cause for a waiver defect. Any bid not accompanied by such security will be excluded from consideration.

### **PERFORMANCE AND LABOR AND MATERIAL BOND**

The successful bidder, within seven (7) business days after notification of award, will be required to furnish Performance and Labor and Material Bond provided by a company authorized to issue such bonds in the State of Connecticut, or Certified Check or properly executed Irrevocable Letter of Credit equal to a hundred per cent (100%) of the award.

In the event that the Contractor were required to provide evidence of insurance and a performance bond does not do so before beginning work, the Town of Stratford reserves the right to withhold payment from such supplier until the evidence of insurance and performance bond has been received by the Town.

All payment and performance bonds shall be written by a surety company or companies licensed to issue bonds in the State of Connecticut, and shall have at least an A-VIII policy holders rating, as reported by A.M. Best Rating Services, or otherwise deemed acceptable by the Town. The Town always reserves the right to reject surety companies, if approved surety bonds cannot be provided the contract shall be terminated.

A complete list of certified surety companies can be accessed on the U.S. Government Department of Treasury website: [https://www.fiscal.treasury.gov/fsreports/ref/suretyBnd/c570\\_a-z.htm](https://www.fiscal.treasury.gov/fsreports/ref/suretyBnd/c570_a-z.htm)

### **BOND REQUIREMENT – NON-RESIDENT CONTRACTORS**

1. Non-resident contractors are required to deposit with the Department of Revenue Services a sum equivalent to 5% of the total contract value, as assurance that personal property taxes and/or any other State taxes assessed and due the State during the contract will be paid.
2. If this surety is not deposited with the State, the Town is required to deduct and submit to the State 5% of the total contract value.

### **PERMITS**

The contractor shall be responsible for securing all necessary permits, state and local, and as required by the Town of Stratford.

### **PAYMENT PROCEDURES**

No voucher, claim or charge against the Town shall be paid without the approval of the Director of Finance for correctness and legality.

### **PAYMENT PERIOD**

The Town of Stratford shall put forth its best effort to make payment within thirty days (30) after delivery of the item acceptance of the work, or receipt of a properly completed invoice, whichever is later. Payment period shall be net thirty days (30) unless otherwise specified. For projects that do not require a performance or bid bond, The Town of Stratford reserves the right to retain five percent (5%) of total bid amount, which is payable ninety (90) days after final payment or acceptance of the work.

### **THE CONTRACTOR**

The Contractor for the work described shall be thoroughly familiar with the requirements of all specifications, and the actual physical conditions of various job sites. The submission of a proposal shall be construed as evidence that the Contractor has examined the actual job conditions, requirements, and specifications. Any claim for labor, equipment, or materials required, or difficulties encountered which could have been foreseen had such an examination been carefully made will not be recognized.

### **ASSIGNMENT OF CONTRACT**

No contract may be assigned or transferred without the consent of the Town of Stratford.

### **AWARD OF BIDS**

Contracts and purchases will be made or entered into with the lowest responsible bidder meeting specifications, except as otherwise specified in the invitation. If more than one item is specified in the invitation, the Town of Stratford reserves the right to determine the low bidder on an individual basis or on the basis of all items included in the Invitation for Bids, unless otherwise expressed by the Town.

### **BIDDING FOR PUBLIC WORK OR IMPROVEMENT**

Any public work or improvement costing more than seven thousand five hundred (\$7,500.00) dollars shall be executed by contract except where specified work or improvement is authorized by the council based on detailed estimates submitted by the department authorized to execute such work or improvement.

All contracts for more than seven thousand five hundred (\$7,500.00) dollars, shall be awarded to the lowest responsible bidder, after public advertisement and competition, as may be prescribed by ordinance.

The Mayor shall establish reasonable regulations for prefiling sub bids on construction contracts where it is anticipated that the contracting party shall subcontract all or a portion of the work to be done.

Any public work or improvement costing more than \$7,500 shall be executed by contract except where specified work or improvement is authorized by the Council based on detailed estimates submitted by the Department authorized to execute such work or improvement. All contracts under this section shall be awarded by the Town Council to the lowest responsible bidder, after public advertisement as specified above.

### **NONUSE OF WASTES**

- A. All bids and contracts related to the retention of services to construct or maintain any publicly owned and/or maintained road or real property within the Town of Stratford shall include a provision stating that no materials containing natural gas or oil waste shall be utilized in providing such a service.
- B. All bids and contracts related to the purchase or acquisition of materials to be used to construct or maintain any publicly owned and/or maintained road or real property within the Town of Stratford shall include a provision stating that no materials containing natural gas or oil waste shall be provided to the Town of Stratford.
- C. The following statement, which shall be a sworn statement under penalty of perjury, shall be included in all bids related to the purchase or acquisition of materials to be used to construct or maintain any publicly owned and/or maintained road or real property within the Town of Stratford and all bids related to the retention of services to construct or maintain any publicly owned and/or maintained road or real property within the Town of Stratford:

"We \_\_\_\_ hereby submit a bid for materials, equipment and/or labor for the Town of Stratford. The bid is for bid documents titled \_\_\_\_\_. We hereby certify under penalty of perjury that no natural gas waste or oil waste will be used by the undersigned bidder or any contractor, subcontractor, agent or vendor agent in connection with the bid; nor will the undersigned bidder or any subcontractor, agent or vendor agent thereof apply any natural gas waste or oil waste to any road or real property within the Town of Stratford as a result of the submittal of this bid if selected."

### **CHANGE ORDERS**

Approval Required: Except as specified herein, when any public work or improvement has been executed by contract, no changes in the terms, conditions or scope of said contract nor deviations from the specifications made a part of that contract which would result in any way in an increase in the cost of that contract to the Town shall be allowed except by the approval of the Council.

Review: Any request for change orders shall first be considered by an appropriate committee appointed and then referred to the Council for appropriate action.

Mayor's Approval: Notwithstanding any provision to the contrary herein, the Mayor, acting upon the advice of the Town Engineer, shall have the authority to approve any such changes or deviations without the approval of the Council, provided that the cost of any such changes or deviations does not exceed the sum of \$5,000, and further provided that, in the opinion of the Mayor, due to extraordinary conditions, unforeseen contingencies, market conditions or the nature of the requested change, it would not be feasible or in the best interest of the Town to delay approval of the requested change.

### **GUARANTEE**

Equipment, materials and/or work executed shall be guaranteed for a minimum period of one (2) years against defective material and workmanship. The cost of all labor, materials, shipping charges and other expenses in conjunction with the replacement of defective equipment, and/or unsatisfactory work, shall be borne by the Contractor.

### **CATALOGUE REFERENCE**

Unless expressly stated otherwise, any and all reference to commercial types, sales, trade names and catalogues are intended to be descriptive only and not restrictive; the intent is to indicate the kind and quality of the articles that will be acceptable. Bids on other equivalent makes, or with reference to other catalogue items will be considered. The bidder is to clearly state exactly what will be furnished. Where possible and feasible, submit an illustration, descriptive material, and/or product sample.

### **OSHA**

The bidder will certify all equipment complies with all regulations and conditions stipulated under the Williams-Steiger Occupational Safety and Health Act of 1971, as amended. The successful bidder will further certify that all items furnished under this project will conform and comply with Federal and State of Connecticut OSHA standards. The successful bidder will agree to indemnify and hold harmless the Town of Stratford for any and all damages that may be assessed against the Town.

### **LIFE CYCLE COSTING**

Where applicable, Life Cycle Costing will be used as a criterion for awarding bids. This is a method of calculating total cost of ownership of an item over the life of the product, which may include operation and maintenance expenses, transportation, salvage value, and/or disposal costs.

### **INSURANCE**

The Contractor shall not commence any work under the Contract until all insurance required by this section has been obtained and Certificates of Insurance and any other evidence of required coverage requested by the Town, including a copy of the policy itself, have been received and approved by the Town.

Such policies shall stipulate that no coverage can be changed or canceled, including for non-payment of premium, unless the Town has had thirty (30) days prior notice in writing. Certificates of renewals or changes in policies shall be delivered to the Owner at least thirty (30) days prior to the expiration of the policy.

All insurance issuers chosen by the Contractor must be licensed to do business in the State of Connecticut and rated A- or better by A.M. Best Rating Services.

The Town always reserves the right to reject insurance companies, if approved insurance policies cannot be provided the contract shall be terminated.

The insurance requirements set forth below are minimum limits of coverage only and in no way limit the Contractor's liability.

The following insurance is required to be maintained in full force until all work required by the contract has been fully completed, except that Products/Completed Operations coverage shall be maintained for five (5) years.

Worker's Compensation Insurance: The Contractor shall carry Worker's Compensation and Employer's Liability Insurance in the form and in such amounts as may be currently required to comply with the Labor Laws of the State of Connecticut.

Automobile Insurance: The Contractor shall carry and maintain during the life of the Contract a policy with a combined single limit of \$2,000,000 and rider CA9948 or equivalent.

This policy shall include all liability of the Contractor arising from the operation of all self-owned motor vehicles used in the performance of the Contract; and shall also include a "non-Ownership" provision covering the operation of motor vehicles not owned by the Contractor, but used in the performance of the work.

**INSURANCE** (continued)

**Commercial General Liability:**

- § Bodily Injury and Property Damage \$2,000,000
- § Products/Completed Operations \$2,000,000

This policy shall include Subcontractor's Liability coverage, protecting the Contractor and the Town against liability arising out of the activities of Subcontractors engaged by him in the performance of the work.

**Umbrella Policy:** An umbrella policy in the amount of \$5,000,000, covering general liability, auto liability, and employer liability is required.

**Pollution Liability Insurance:** Where applicable, a policy in the amount of \$5,000,000 including coverage for transport and other offsite risks. Such policy must be given to the Town for review and determination of acceptability before an award will be made.

**Waiver of Subrogation:** Waiver of subrogation is required on all policies.

**Additional Insureds:** The Town of Stratford, Stratford Board of Education, its officers, officials, employees, agents, Boards, and Commissions shall be named as Additional Insureds. The coverage shall be primary and non-contributory and contain no special limitations on the scope of protection afforded to the Town of Stratford. A waiver of subrogation applies under general liability, auto liability and workers compensation.

The coverage shall be primary and non-contributory and contain no special limitations on the scope of protection afforded to the Town of Stratford. A waiver of subrogation applies under general liability, auto liability and workers compensation.

**Subcontractor's Insurance:** Each Subcontractor engaged by the Contractor to perform any work under the Contract shall obtain all insurance required of the Contractor in the same amounts and subject to the same provisions specified above for the Contractor, including the Additional Insured requirement. Certificates of Insurance shall be submitted to the Contractor and the Town and approved by the Town, before commencing any work.

**HOLD HARMLESS**

Contractor shall defend, indemnify, and hold harmless the Town of Stratford, its officers, employees, agents or volunteers, from and against any and all claims and demands of any nature for any loss, damage or injury which any person may suffer by reason of, or in any way arising out of, this Agreement, unless caused by the sole negligence of the Town.

**FEDERAL, STATE, AND LOCAL LAWS**

All applicable Federal, State and local laws, rules and regulations of all authorities having jurisdiction over the locality of the project shall apply to the contract and are deemed to be included herein. If the total amount of the project, including any current or future change orders, exceeds \$100,000.00 all work is to be done in accordance with Connecticut Department of Labor (CT-DOL) rules and regulations. More information may be obtained from: [www.ctdol.state.ct.us](http://www.ctdol.state.ct.us)

The Davis-Bacon and Related Acts, shall apply to contractors and subcontractors performing on federally funded or assisted contracts in excess of \$2,000 for the construction, alteration, or repair (including painting and decorating) of public buildings or public works. More information may be obtained from: <https://www.dol.gov/whd/govcontracts/dbra.htm>

NOTE: The Town shall apply the most current wage decision applicable at the time of contract award.

**CONFLICT OF INTEREST**

No officer or employee or member of any elective or appointive board, commission, committee or council of the Town, whether temporary or permanent, shall have or acquire any financial interest gained from a successful bid, direct or indirect, in any project, matter, contract or business within his/her jurisdiction or the jurisdiction of the board, commission, committee or council of which he/she is a member. Nor shall the officer / employee / member have any financial interest, direct or indirect, in any contract or proposed contract for materials or services to be furnished or used in connection with any project, matter or thing which comes under his/her jurisdiction or the jurisdiction of the board, commission, committee or council of which he/she is a member.

### **SCOPE OF WORK / SITE INSPECTIONS**

The bidder declares that the scope of the work has been thoroughly reviewed and any questions resolved (see above for name and number of individual to contact for questions). If applicable, the bidder further declares that the site has been inspected as called for in the specifications (q.v.).

### **EXCEPTION TO SPECIFICATIONS**

No protest regarding the validity or appropriateness of the specifications or of the Invitation for Bids will be considered, unless the protest is filed in writing with the Purchasing Agent prior to the closing date for the bids. All bid proposals rendered shall be considered meeting the attached specifications unless exceptions are noted on a separate page dated and signed by the bidder.

### **UNLESS OTHERWISE NOTED**

It will be assumed that all terms and conditions and specifications will be complied with and will be considered as part of the Bid Proposal.

### **TAX EXEMPT**

Federal Tax Exemption 06-6002103.

Exempt from State Sales Tax under State General Statutes Chapter 219-Section 12-412 Subsection A.

### **COMMISSION ON HUMAN RIGHTS AND OPPORTUNITIES (CHRO)**

All bidders must complete, sign, and return the "CHRO Contract Compliance Regulations Notification to Bidders" form to the Town at the time of bid opening. Bids not including this form will be considered incomplete and rejected. This form is attached, and can also be found at [http://www.ct.gov/chro/lib/chro/pdf/notificationto\\_bidders.pdf](http://www.ct.gov/chro/lib/chro/pdf/notificationto_bidders.pdf)

The Contractor shall set a goal of twenty-five per cent (25%) of the state-funded portion of the contract for award to eligible subcontractors holding current small business enterprise (SBE) certification from the DAS under the provisions of C.G.S. 4a-60g. Of the portion of contracts set aside for SBE's, a goal of twenty-five percent (25%) (or 6.25% of the value of the entire contract funded by the state) must be set aside for awards to eligible contractors holding current minority business enterprise certification (i.e.: DAS certified Minority ("MBE"), Women ("WBE") and/or Disabled ("DisBE") owned businesses). The contractor, general contractor, construction manager at risk must make good faith efforts to employ minority business enterprises as subcontractors and suppliers of materials on such projects.

The contractor shall file within 30 days following the intent to award notice, an Affirmative Action Plan or Set Aside plan. This plan must be approved by the CHRO prior to the award of the construction contract.

Forms can be found at [http://www.ct.gov/opm/cwp/view.asp?a=2982&q=390928&opmNav\\_GID=1806](http://www.ct.gov/opm/cwp/view.asp?a=2982&q=390928&opmNav_GID=1806)

Commission on Human Rights and Opportunities: <https://www.ct.gov/chro/site/default.asp>

### **DAS PREQUALIFICATION OF BIDDERS**

- A. Municipal contracts for the construction or renovation of a public works project, where the estimated value is \$500,000 or greater, will need to comply with C.G.S. Sec. 4b-91. In such cases the contractors must be pre-qualified by the State of Connecticut Department of Administrative Services (DAS). When applicable, this requirement will need to be included in the Invitation to Bid as a prerequisite for selecting the Lowest Responsible and Qualified Bidder.
- B. "Prequalification" means prequalification issued by DAS to bid on a contract or perform work pursuant to a contract for the construction, reconstruction, alteration, remodeling, repair or demolition of any public building or any other public work by the state or a municipality.
- C. It is permissible to use AIA form A305, Contractor's Qualification
  - i. Statement, as a prerequisite to bidding, provided prequalification.
  - ii. Does not prevent minority/women owned firms from bidding.
  - iii. Consult your architect.

**COMMISSION ON HUMAN RIGHTS AND OPPORTUNITIES**  
**CONTRACT COMPLIANCE REGULATIONS**  
**NOTIFICATION TO BIDDERS**

(Revised 09/17/07)

The contract to be awarded is subject to contract compliance requirements mandated by Sections 4a-60 and 4a-60a of the Connecticut General Statutes; and, when the awarding agency is the State, Sections 46a-71(d) and 46a-81i(d) of the Connecticut General Statutes. There are Contract Compliance Regulations codified at Section 46a-68j-21 through 43 of the Regulations of Connecticut State Agencies, which establish a procedure for awarding all contracts covered by Sections 4a-60 and 46a-71(d) of the Connecticut General Statutes.

According to Section 46a-68j-30(9) of the Contract Compliance Regulations, every agency awarding a contract subject to the contract compliance requirements has an obligation to “aggressively solicit the participation of legitimate minority business enterprises as bidders, contractors, subcontractors and suppliers of materials.” “Minority business enterprise” is defined in Section 4a-60 of the Connecticut General Statutes as a business wherein fifty-one percent or more of the capital stock, or assets belong to a person or persons: “(1) Who are active in daily affairs of the enterprise; (2) who have the power to direct the management and policies of the enterprise; and (3) who are members of a minority, as such term is defined in subsection (a) of Section 32-9n.” “Minority” groups are defined in Section 32-9n of the Connecticut General Statutes as “(1) Black Americans . . . (2) Hispanic Americans . . . (3) persons who have origins in the Iberian Peninsula . . . (4) Women . . . (5) Asian Pacific Americans and Pacific Islanders; (6) American Indians . . .” An individual with a disability is also a minority business enterprise as provided by Section 4a-60g of the Connecticut General Statutes. The above definitions apply to the contract compliance requirements by virtue of Section 46a-68j-21(11) of the Contract Compliance Regulations.

The awarding agency will consider the following factors when reviewing the bidder’s qualifications under the contract compliance requirements:

- (a) the bidder’s success in implementing an affirmative action plan;
- (b) the bidder’s success in developing an apprenticeship program complying with Sections 46a-68-1 to 46a-68-17 of the Administrative Regulations of Connecticut State Agencies, inclusive;
- (c) the bidder’s promise to develop and implement a successful affirmative action plan;
- (d) the bidder’s submission of employment statistics contained in the “Employment Information Form”, indicating that the composition of its workforce is at or near parity when compared to the racial and sexual composition of the workforce in the relevant labor market area; and
- (e) the bidder’s promise to set aside a portion of the contract for legitimate minority business enterprises. See Section 46a-68j-30(10)(E) of the Contract Compliance Regulations.

---

**INSTRUCTIONS AND OTHER INFORMATION**

The following BIDDER CONTRACT COMPLIANCE MONITORING REPORT must be completed in full, signed, and submitted with the bid for this contract. The contract awarding agency and the Commission on Human Rights and Opportunities will use the information contained thereon to determine the bidders compliance to Sections 4a-60 and 4a-60a CONN. GEN. STAT., and Sections 46a-68j-23 of the Regulations of Connecticut State Agencies regarding equal employment opportunity, and the bidder’s □□good faith efforts to include minority business enterprises as subcontractors and suppliers for the work of the contract.

1) **Definition of Small Contractor**

Section 4a-60g CONN. GEN. STAT. defines a small contractor as a company that has been doing business under the same management and control and has maintained its principal place of business in Connecticut for a one year period immediately prior to its application for certification under this section, had gross revenues not exceeding ten million dollars in the most recently completed fiscal year, and at least fifty-one percent of the ownership of which is held by a person or persons who are active in the daily affairs of the company, and have the power to direct the management and policies of the company, except that a nonprofit corporation shall be construed to be a small contractor if such nonprofit corporation meets the requirements of subparagraphs (A) and (B) of subdivision 4a-60g CONN. GEN. STAT.

**MANAGEMENT:** Managers plan, organize, direct, and control the major functions of an organization through subordinates who are at the managerial or supervisory level. They make policy decisions and set objectives for the company or departments. They are not usually directly involved in production or providing services. Examples include top executives, public relations managers, managers of operations specialties (such as financial, human resources, or purchasing managers), and construction and engineering managers.

**BUSINESS AND FINANCIAL OPERATIONS:** These occupations include managers and professionals who work with the financial aspects of the business. These occupations include accountants and auditors, purchasing agents, management analysts, labor relations specialists, and budget, credit, and financial analysts.

**MARKETING AND SALES:** Occupations related to the act or process of buying and selling products and/or services such as sales engineer, retail sales workers and sales representatives including wholesale.

**LEGAL OCCUPATIONS:** In-House Counsel who is charged with providing legal advice and services in regards to legal issues that may arise during the course of standard business practices. This category also includes assistive legal occupations such as paralegals, legal assistants.

**COMPUTER SPECIALISTS:** Professionals responsible for the computer operations within a company are grouped in this category. Examples of job titles in this category include computer programmers, software engineers, database administrators, computer scientists, systems analysts, and computer support specialists

**ARCHITECTURE AND ENGINEERING:** Occupations related to architecture, surveying, engineering, and drafting are included in this category. Some of the job titles in this category include electrical and electronic engineers, surveyors, architects, drafters, mechanical engineers, materials engineers, mapping technicians, and civil engineers.

**OFFICE AND ADMINISTRATIVE SUPPORT:** All clerical-type work is included in this category. These jobs involve the preparing, transcribing, and preserving of written communications and records; collecting accounts; gathering and distributing information; operating office machines and electronic data processing equipment; and distributing mail. Job titles listed in this category include telephone operators, bill and account collectors, customer service representatives, dispatchers, secretaries and administrative assistants, computer operators and clerks (such as payroll, shipping, stock, mail and file).

**BUILDING AND GROUNDS CLEANING AND MAINTENANCE:** This category includes occupations involving landscaping, housekeeping, and janitorial services. Job titles found in this category include supervisors of landscaping or housekeeping, janitors, maids, grounds maintenance workers, and pest control workers.

**CONSTRUCTION AND EXTRACTION:** This category includes construction trades and related occupations. Job titles found in this category include boilermakers, masons (all types), carpenters, construction laborers, electricians, plumbers (and related trades), roofers, sheet metal workers, elevator installers, hazardous materials removal workers, paperhangers, and painters. Paving, surfacing, and tamping equipment operators; drywall and ceiling tile installers; and carpet, floor and tile installers and finishers are also included in this category. First line supervisors, foremen, and helpers in these trades are also grouped in this category..

**INSTALLATION, MAINTENANCE AND REPAIR:** Occupations involving the installation, maintenance, and repair of equipment are included in this group. Examples of job titles found here are heating, ac, and refrigeration mechanics and installers; telecommunication line installers and repairers; heavy vehicle and mobile equipment service technicians and mechanics; small engine mechanics; security and fire alarm systems installers; electric/electronic repair, industrial, utility and transportation equipment; millwrights; riggers; and manufactured building and mobile home installers. First line supervisors, foremen, and helpers for these jobs are also included in the category.

**MATERIAL MOVING WORKERS:** The job titles included in this group are Crane and tower operators; dredge, excavating, and lading machine operators; hoist and winch operators; industrial truck and tractor operators; cleaners of vehicles and equipment; laborers and freight, stock, and material movers, hand; machine feeders and offbearers; packers and packagers, hand; pumping station operators; refuse and recyclable material collectors; and miscellaneous material moving workers.

**PRODUCTION WORKERS:** The job titles included in this category are chemical production machine setters, operators and tenders; crushing/grinding workers; cutting workers; inspectors, testers sorters, samplers, weighers; precious stone/metal workers; painting workers; cementing/gluing machine operators and tenders; etchers/engravers; molders, shapers and casters except for metal and plastic; and production workers.



<p><u>White</u> (not of Hispanic Origin)- All persons having origins in any of the original peoples of Europe, North Africa, or the Middle East.</p> <p><u>Black</u>(not of Hispanic Origin)- All persons having origins in any of the Black racial groups of Africa.</p> <p><u>Hispanic</u>- All persons of Mexican, Puerto Rican, Cuban, Central or South American, or other Spanish culture or origin, regardless of race.</p>	<p><u>Asian or Pacific Islander</u>- All persons having origins in any of the original peoples of the Far East, Southeast Asia, the Indian subcontinent, or the Pacific Islands. This area includes China, India, Japan, Korea, the Philippine Islands, and Samoa.</p> <p><u>American Indian or Alaskan Native</u>- All persons having origins in any of the original peoples of North America, and who maintain cultural identification through tribal affiliation or community recognition.</p>
---	---

**BIDDER CONTRACT COMPLIANCE MONITORING REPORT**

**PART I - Bidder Information**

Company Name Street Address City & State Chief Executive	Bidder Federal Employer Identification Number _____ Or Social Security Number _____
Major Business Activity (brief description)	Bidder Identification (response optional/definitions on page 1)  -Bidder is a small contractor. Yes__ No__ -Bidder is a minority business enterprise Yes__ No__ (If yes, check ownership category) Black__ Hispanic__ Asian American__ American Indian/Alaskan Native__ Iberian Peninsula__ Individual(s) with a Physical Disability__ Female__
Bidder Parent Company (If any)	- Bidder is certified as above by State of CT Yes__ No__
Other Locations in Ct. (If any)	

**PART II - Bidder Nondiscrimination Policies and Procedures**

1. Does your company have a written Affirmative Action/Equal Employment Opportunity statement posted on company bulletin boards? Yes__ No__	7. Do all of your company contracts and purchase orders contain non-discrimination statements as required by Sections 4a-60 & 4a-60a Conn. Gen. Stat.? Yes__ No__
2. Does your company have the state-mandated sexual harassment prevention in the workplace policy posted on company bulletin boards? Yes__ No__	8. Do you, upon request, provide reasonable accommodation to employees, or applicants for employment, who have physical or mental disability? Yes__ No__
3. Do you notify all recruitment sources in writing of your company's Affirmative Action/Equal Employment Opportunity employment policy? Yes__ No__	9. Does your company have a mandatory retirement age for all employees? Yes__ No__
4. Do your company advertisements contain a written statement that you are an Affirmative Action/Equal Opportunity Employer? Yes__ No__	10. If your company has 50 or more employees, have you provided at least two (2) hours of sexual harassment training to all of your supervisors? Yes__ No__ NA__
5. Do you notify the Ct. State Employment Service of all employment openings with your company? Yes__ No__	11. If your company has apprenticeship programs, do they meet the Affirmative Action/Equal Employment Opportunity requirements of the apprenticeship standards of the Ct. Dept. of Labor? Yes__ No__ NA__
6. Does your company have a collective bargaining agreement with workers? Yes__ No__ 6a. If yes, do the collective bargaining agreements contain non-discrimination clauses covering all workers? Yes__ No__ 6b. Have you notified each union in writing of your commitments under the nondiscrimination requirements of contracts with the state of Ct? Yes__ No__	12. Does your company have a written affirmative action Plan? Yes__ No__ If no, please explain.  13. Is there a person in your company who is responsible for equal employment opportunity? Yes__ No__ If yes, give name and phone number. _____ _____

1. Will the work of this contract include subcontractors or suppliers? Yes\_\_ No\_\_

1a. If yes, please list all subcontractors and suppliers and report if they are a small contractor and/or a minority business enterprise. (defined on page 1 / use additional sheet if necessary)

1b. Will the work of this contract require additional subcontractors or suppliers other than those identified in 1a. above?

Yes\_\_ No\_\_

**PART IV - Bidder Employment Information**

Date:

JOB CATEGORY *	OVERALL TOTALS	WHITE (not of Hispanic origin)		BLACK (not of Hispanic origin)		HISPANIC		ASIAN or PACIFIC ISLANDER		AMERICAN INDIAN or ALASKAN NATIVE	
		Male	Female	Male	Female	Male	Female	Male	Female	male	female
Management											
Business & Financial Ops											
Marketing & Sales											
Legal Occupations											
Computer Specialists											
Architecture/Engineering											
Office & Admin Support											
Bldg/ Grounds Cleaning/Maintenance											
Construction & Extraction											
Installation, Maintenance & Repair											
Material Moving Workers											
Production Occupations											
TOTALS ABOVE											
Total One Year Ago											
FORMAL ON THE JOB TRAINEES (ENTER FIGURES FOR THE SAME CATEGORIES AS ARE SHOWN ABOVE)											
Apprentices											
Trainees											

\*NOTE: JOB CATEGORIES CAN BE CHANGED OR ADDED TO (EX. SALES CAN BE ADDED OR REPLACE A CATEGORY NOT USED IN YOUR COMPANY)

1. Which of the following recruitment sources are used by you? (Check yes or no, and report percent used)				2. Check (X) any of the below listed requirements that you use as a hiring qualification  (X)		3. Describe below any other practices or actions that you take which show that you hire, train, and promote employees without discrimination
SOURCE	YES	NO	% of applicants provided by source			
State Employment Service					Work Experience	
Private Employment Agencies					Ability to Speak or Write English	
Schools and Colleges					Written Tests	
Newspaper Advertisement					High School Diploma	
Walk Ins					College Degree	
Present Employees					Union Membership	
Labor Organizations					Personal Recommendation	
Minority/Community Organizations					Height or Weight	
Others (please identify)					Car Ownership	
					Arrest Record	
					Wage Garnishments	

Certification (Read this form and check your statements on it CAREFULLY before signing). I certify that the statements made by me on this BIDDER CONTRACT COMPLIANCE MONITORING REPORT are complete and true to the best of my knowledge and belief, and are made in good faith. I understand that if I knowingly make any misstatements of facts, I am subject to be declared in non-compliance with Section 4a-60, 4a-60a, and related sections of the CONN. GEN. STAT.

(Signature)	(Title)	(Date Signed)	(Telephone)
-------------	---------	---------------	-------------



**BID FORM**

Bids must be submitted to the Town of Stratford Purchasing Office, attention Phillip Ryan, Purchasing Agent, on the following form signed by an authorized company officer. Bids will be opened on **Tuesday, June 18, 2019, 11:00am.**

**Phillip Ryan, Purchasing Agent  
Town of Stratford  
2725 Main Street  
Stratford, CT 06615**

**Roof Replacement:  
Stratford Academy – Johnson House  
719 Birdseye Street  
Stratford, CT 06615**

To Whom It May Concern:

(I, We) \_\_\_\_\_ the undersigned having visited the project site at **Stratford Academy – Johnson House** and having familiarized ourselves with the local conditions affecting the cost of the work and with Contract Documents and all addenda thereto, hereby propose to furnish all labor, materials, tools, equipment, insurance to pay all applicable taxes, and to do and perform all things as provided in the drawings and specifications for the following sum(s):

**BASE BID:**

**Refer to enclosed drawings and specifications.**

**Contractor shall include all monies and fees to complete documented roof replacement project as indicated in bid documents. Contractor shall include a \$40,000 allowance in base bid number for unforeseen conditions and changes to be used at Architect and Owners discretion. Any unused portion of allowance shall be credited back to owner.**

\*Written Form: \_\_\_\_\_

\*Dollars: (\$\_\_\_\_\_)

**\*PLEASE NOTE THAT STATE OF CONNECTICUT PREVAILING WAGES MUST BE USED IF TOTAL BID EXCEEDS \$100,000.**

**ALTERNATE #1 (DEDUCT):**

**Mechanically attach ALL layers of insulation and coverboard in lieu of adhesive.**

\*Written Form: \_\_\_\_\_

\*Dollars: (\$ \_\_\_\_\_)

**\*Please note the ALTERNATE COST ONLY, not the basebid plus/minus alternate costs in Alternate bid numbers.**

**UNIT PRICES:**

**Contractor must include unit prices for all items listed below, or bid could be rejected at client discretion. Shall include installed price.**

- 1. Thermoplastic Walkway: \$ \_\_\_\_\_ Per 10 Lineal Feet
- 2. Roof Drain (Including Deck Reinforcement): \$ \_\_\_\_\_ Each
- 3. Roof Drain Piping: \$ \_\_\_\_\_ Per Lineal Feet
- 4. Thru-Wall Counterflashing: \$ \_\_\_\_\_ Per Lineal Feet
- 5. Fluid Applied Flashing: \$ \_\_\_\_\_ Per Square Foot
- 6. Steel Deck Replacement: \$ \_\_\_\_\_ Per Square Foot
- 7. Steel Deck Nesting: \$ \_\_\_\_\_ Per Square Foot
- 8. Steel Deck Cleaning/Coating/Painting: \$ \_\_\_\_\_ Per Square Foot
- 9. 2"x10" Wood Blocking: \$ \_\_\_\_\_ Per Lineal Feet
- 10. Labor - Forman: \$ \_\_\_\_\_ Per Hour
- 11. Labor - Roofer: \$ \_\_\_\_\_ Per Hour
- 12. Labor – Sheet Metal: \$ \_\_\_\_\_ Per Hour
- 13. Labor – Laborer: \$ \_\_\_\_\_ Per Hour

**ADDENDA**

In submitting this proposal, I have received and included in this Proposal, the following Addenda:

Addendum No.	Date
_____	_____
_____	_____
_____	_____
_____	_____
_____	_____

Signed: \_\_\_\_\_

	Signature	Corporate Seal
Company Name	: _____	
Address	: _____	
City, St, Zip Code	: _____	
Phone	: (_____) - _____ - _____	
Fax	: (_____) - _____ - _____	







# AIA<sup>®</sup> Document A305<sup>™</sup> – 1986

## Contractor's Qualification Statement

The Undersigned certifies under oath that the information provided herein is true and sufficiently complete so as not to be misleading.

**SUBMITTED TO:** Town of Stratford  
**ADDRESS:** 2725 Main St., Stratford, CT 06615

**SUBMITTED BY:**

**NAME:**

**ADDRESS:**

**PRINCIPAL OFFICE:**

- Corporation
- Partnership
- Individual
- Joint Venture
- Other

**NAME OF PROJECT** (if applicable):

**TYPE OF WORK** (file separate form for each Classification of Work):

- General Construction
- HVAC
- Electrical
- Plumbing
- Other (please specify)

### § 1. ORGANIZATION

§ 1.1 How many years has your organization been in business as a Contractor?

§ 1.2 How many years has your organization been in business under its present business name?

§ 1.2.1 Under what other or former names has your organization operated?

§ 1.3 If your organization is a corporation, answer the following:

§ 1.3.1 Date of incorporation:

§ 1.3.2 State of incorporation:

§ 1.3.3 President's name:

### ADDITIONS AND DELETIONS:

The author of this document has added information needed for its completion. The author may also have revised the text of the original AIA standard form. An *Additions and Deletions Report* that notes added information as well as revisions to the standard form text is available from the author and should be reviewed. A vertical line in the left margin of this document indicates where the author has added necessary information and where the author has added to or deleted from the original AIA text.

This document has important legal consequences. Consultation with an attorney is encouraged with respect to its completion or modification.

This form is approved and recommended by the American Institute of Architects (AIA) and The Associated General Contractors of America (AGC) for use in evaluating the qualifications of contractors. No endorsement of the submitting party or verification of the information is made by AIA or AGC.

§ 1.3.4 Vice-president's name(s)

§ 1.3.5 Secretary's name:

§ 1.3.6 Treasurer's name:

§ 1.4 If your organization is a partnership, answer the following:

§ 1.4.1 Date of organization:

§ 1.4.2 Type of partnership (if applicable):

§ 1.4.3 Name(s) of general partner(s)

§ 1.5 If your organization is individually owned, answer the following:

§ 1.5.1 Date of organization:

§ 1.5.2 Name of owner:

§ 1.6 If the form of your organization is other than those listed above, describe it and name the principals:

## § 2. LICENSING

§ 2.1 List jurisdictions and trade categories in which your organization is legally qualified to do business, and indicate registration or license numbers, if applicable.

§ 2.2 List jurisdictions in which your organization's partnership or trade name is filed.

## § 3. EXPERIENCE

§ 3.1 List the categories of work that your organization normally performs with its own forces.

§ 3.2 Claims and Suits. (If the answer to any of the questions below is yes, please attach details.)

§ 3.2.1 Has your organization ever failed to complete any work awarded to it?

§ 3.2.2 Are there any judgments, claims, arbitration proceedings or suits pending or outstanding against your organization or its officers?

§ 3.2.3 Has your organization filed any law suits or requested arbitration with regard to construction contracts within the last five years?

§ 3.3 Within the last five years, has any officer or principal of your organization ever been an officer or principal of another organization when it failed to complete a construction contract? (If the answer is yes, please attach details.)

§ 3.4 On a separate sheet, list major construction projects your organization has in progress, giving the name of project, owner, architect, contract amount, percent complete and scheduled completion date.

§ 3.4.1 State total worth of work in progress and under contract:

§ 3.5 On a separate sheet, list the major projects your organization has completed in the past five years, giving the name of project, owner, architect, contract amount, date of completion and percentage of the cost of the work performed with your own forces.

§ 3.5.1 State average annual amount of construction work performed during the past five years:

§ 3.6 On a separate sheet, list the construction experience and present commitments of the key individuals of your organization.

#### § 4. REFERENCES

§ 4.1 Trade References:

§ 4.2 Bank References:

§ 4.3 Surety:

§ 4.3.1 Name of bonding company:

§ 4.3.2 Name and address of agent:

#### § 5. FINANCING

§ 5.1 Financial Statement.

§ 5.1.1 Attach a financial statement, preferably audited, including your organization's latest balance sheet and income statement showing the following items:

Current Assets (e.g., cash, joint venture accounts, accounts receivable, notes receivable, accrued income, deposits, materials inventory and prepaid expenses);

Net Fixed Assets;

Other Assets;

Current Liabilities (e.g., accounts payable, notes payable, accrued expenses, provision for income taxes, advances, accrued salaries and accrued payroll taxes);

Other Liabilities (e.g., capital, capital stock, authorized and outstanding shares par values, earned surplus and retained earnings).

§ 5.1.2 Name and address of firm preparing attached financial statement, and date thereof:

§ 5.1.3 Is the attached financial statement for the identical organization named on page one?

§ 5.1.4 If not, explain the relationship and financial responsibility of the organization whose financial statement is provided (e.g., parent-subsiidiary).

§ 5.2 Will the organization whose financial statement is attached act as guarantor of the contract for construction?

**§ 6. SIGNATURE**

§ 6.1 Dated at this day of

Name of Organization:

By:

Title:

§ 6.2

M being duly sworn deposes and says that the information provided herein is true and sufficiently complete so as not to be misleading.

Subscribed and sworn before me this day of

Notary Public:

My Commission Expires:

# AIA<sup>®</sup> Document A310<sup>™</sup> – 2010

## **Bid Bond**

**CONTRACTOR:**  
*(Name, legal status and address)*

**SURETY:**  
*(Name, legal status and principal place of business)*

**OWNER:**  
*(Name, legal status and address)*

**BOND AMOUNT: \$**

**PROJECT:**  
*(Name, location or address, and Project number, if any)*

**ADDITIONS AND DELETIONS:**  
The author of this document has added information needed for its completion. The author may also have revised the text of the original AIA standard form. An *Additions and Deletions Report* that notes added information as well as revisions to the standard form text is available from the author and should be reviewed. A vertical line in the left margin of this document indicates where the author has added necessary information and where the author has added to or deleted from the original AIA text.

This document has important legal consequences. Consultation with an attorney is encouraged with respect to its completion or modification.

Any singular reference to Contractor, Surety, Owner or other party shall be considered plural where applicable.

The Contractor and Surety are bound to the Owner in the amount set forth above, for the payment of which the Contractor and Surety bind themselves, their heirs, executors, administrators, successors and assigns, jointly and severally, as provided herein. The conditions of this Bond are such that if the Owner accepts the bid of the Contractor within the time specified in the bid documents, or within such time period as may be agreed to by the Owner and Contractor, and the Contractor either (1) enters into a contract with the Owner in accordance with the terms of such bid, and gives such bond or bonds as may be specified in the bidding or Contract Documents, with a surety admitted in the jurisdiction of the Project and otherwise acceptable to the Owner, for the faithful performance of such Contract and for the prompt payment of labor and material furnished in the prosecution thereof; or (2) pays to the Owner the difference, not to exceed the amount of this Bond, between the amount specified in said bid and such larger amount for which the Owner may in good faith contract with another party to perform the work covered by said bid, then this obligation shall be null and void, otherwise to remain in full force and effect. The Surety hereby waives any notice of an agreement between the Owner and Contractor to extend the time in which the Owner may accept the bid. Waiver of notice by the Surety shall not apply to any extension exceeding sixty (60) days in the aggregate beyond the time for acceptance of bids specified in the bid documents, and the Owner and Contractor shall obtain the Surety's consent for an extension beyond sixty (60) days.

If this Bond is issued in connection with a subcontractor's bid to a Contractor, the term Contractor in this Bond shall be deemed to be Subcontractor and the term Owner shall be deemed to be Contractor.

When this Bond has been furnished to comply with a statutory or other legal requirement in the location of the Project, any provision in this Bond conflicting with said statutory or legal requirement shall be deemed deleted herefrom and provisions conforming to such statutory or other legal requirement shall be deemed incorporated herein. When so furnished, the intent is that this Bond shall be construed as a statutory bond and not as a common law bond.

Init.

AIA Document A310<sup>™</sup> – 2010. Copyright © 1963, 1970 and 2010 by The American Institute of Architects. All rights reserved. **WARNING: This AIA<sup>®</sup> Document is protected by U.S. Copyright Law and International Treaties. Unauthorized reproduction or distribution of this AIA<sup>®</sup> Document, or any portion of it, may result in severe civil and criminal penalties, and will be prosecuted to the maximum extent possible under the law.** This document was produced by AIA software at 14:29:28 on 10/24/2011 under Order No.7367275281\_1 which expires on 04/21/2012, and is not for resale.

User Notes:

(1381656683)







# AIA<sup>®</sup> Document A312™ – 2010

## Performance Bond

**CONTRACTOR:**  
*(Name, legal status and address)*

**SURETY:**  
*(Name, legal status and principal place of business)*

**OWNER:**  
*(Name, legal status and address)*

### CONSTRUCTION CONTRACT

Date:  
Amount: \$  
Description:  
*(Name and location)*

### BOND

Date:  
*(Not earlier than Construction Contract Date)*

Amount: \$  
Modifications to this Bond:  None  See Section 16

### CONTRACTOR AS PRINCIPAL

Company: *(Corporate Seal)*

### SURETY

Company: *(Corporate Seal)*

Signature: \_\_\_\_\_  
Name and  
Title:

Signature: \_\_\_\_\_  
Name and  
Title:

*(Any additional signatures appear on the last page of this Performance Bond.)*

*(FOR INFORMATION ONLY — Name, address and telephone)*

**AGENT or BROKER:**

**OWNER'S REPRESENTATIVE:**

*(Architect, Engineer or other party:)*

### ADDITIONS AND DELETIONS:

The author of this document has added information needed for its completion. The author may also have revised the text of the original AIA standard form. An *Additions and Deletions Report* that notes added information as well as revisions to the standard form text is available from the author and should be reviewed. A vertical line in the left margin of this document indicates where the author has added necessary information and where the author has added to or deleted from the original AIA text.

This document has important legal consequences. Consultation with an attorney is encouraged with respect to its completion or modification.

Any singular reference to Contractor, Surety, Owner or other party shall be considered plural where applicable.

Init.

§ 1 The Contractor and Surety, jointly and severally, bind themselves, their heirs, executors, administrators, successors and assigns to the Owner for the performance of the Construction Contract, which is incorporated herein by reference.

§ 2 If the Contractor performs the Construction Contract, the Surety and the Contractor shall have no obligation under this Bond, except when applicable to participate in a conference as provided in Section 3.

§ 3 If there is no Owner Default under the Construction Contract, the Surety's obligation under this Bond shall arise after

- .1 the Owner first provides notice to the Contractor and the Surety that the Owner is considering declaring a Contractor Default. Such notice shall indicate whether the Owner is requesting a conference among the Owner, Contractor and Surety to discuss the Contractor's performance. If the Owner does not request a conference, the Surety may, within five (5) business days after receipt of the Owner's notice, request such a conference. If the Surety timely requests a conference, the Owner shall attend. Unless the Owner agrees otherwise, any conference requested under this Section 3.1 shall be held within ten (10) business days of the Surety's receipt of the Owner's notice. If the Owner, the Contractor and the Surety agree, the Contractor shall be allowed a reasonable time to perform the Construction Contract, but such an agreement shall not waive the Owner's right, if any, subsequently to declare a Contractor Default;
- .2 the Owner declares a Contractor Default, terminates the Construction Contract and notifies the Surety; and
- .3 the Owner has agreed to pay the Balance of the Contract Price in accordance with the terms of the Construction Contract to the Surety or to a contractor selected to perform the Construction Contract.

§ 4 Failure on the part of the Owner to comply with the notice requirement in Section 3.1 shall not constitute a failure to comply with a condition precedent to the Surety's obligations, or release the Surety from its obligations, except to the extent the Surety demonstrates actual prejudice.

§ 5 When the Owner has satisfied the conditions of Section 3, the Surety shall promptly and at the Surety's expense take one of the following actions:

§ 5.1 Arrange for the Contractor, with the consent of the Owner, to perform and complete the Construction Contract;

§ 5.2 Undertake to perform and complete the Construction Contract itself, through its agents or independent contractors;

§ 5.3 Obtain bids or negotiated proposals from qualified contractors acceptable to the Owner for a contract for performance and completion of the Construction Contract, arrange for a contract to be prepared for execution by the Owner and a contractor selected with the Owner's concurrence, to be secured with performance and payment bonds executed by a qualified surety equivalent to the bonds issued on the Construction Contract, and pay to the Owner the amount of damages as described in Section 7 in excess of the Balance of the Contract Price incurred by the Owner as a result of the Contractor Default; or

§ 5.4 Waive its right to perform and complete, arrange for completion, or obtain a new contractor and with reasonable promptness under the circumstances:

- .1 After investigation, determine the amount for which it may be liable to the Owner and, as soon as practicable after the amount is determined, make payment to the Owner; or
- .2 Deny liability in whole or in part and notify the Owner, citing the reasons for denial.

§ 6 If the Surety does not proceed as provided in Section 5 with reasonable promptness, the Surety shall be deemed to be in default on this Bond seven days after receipt of an additional written notice from the Owner to the Surety demanding that the Surety perform its obligations under this Bond, and the Owner shall be entitled to enforce any remedy available to the Owner. If the Surety proceeds as provided in Section 5.4, and the Owner refuses the payment or the Surety has denied liability, in whole or in part, without further notice the Owner shall be entitled to enforce any remedy available to the Owner.



§ 7 If the Surety elects to act under Section 5.1, 5.2 or 5.3, then the responsibilities of the Surety to the Owner shall not be greater than those of the Contractor under the Construction Contract, and the responsibilities of the Owner to the Surety shall not be greater than those of the Owner under the Construction Contract. Subject to the commitment by the Owner to pay the Balance of the Contract Price, the Surety is obligated, without duplication, for

- .1 the responsibilities of the Contractor for correction of defective work and completion of the Construction Contract;
- .2 additional legal, design professional and delay costs resulting from the Contractor's Default, and resulting from the actions or failure to act of the Surety under Section 5; and
- .3 liquidated damages, or if no liquidated damages are specified in the Construction Contract, actual damages caused by delayed performance or non-performance of the Contractor.

§ 8 If the Surety elects to act under Section 5.1, 5.3 or 5.4, the Surety's liability is limited to the amount of this Bond.

§ 9 The Surety shall not be liable to the Owner or others for obligations of the Contractor that are unrelated to the Construction Contract, and the Balance of the Contract Price shall not be reduced or set off on account of any such unrelated obligations. No right of action shall accrue on this Bond to any person or entity other than the Owner or its heirs, executors, administrators, successors and assigns.

§ 10 The Surety hereby waives notice of any change, including changes of time, to the Construction Contract or to related subcontracts, purchase orders and other obligations.

§ 11 Any proceeding, legal or equitable, under this Bond may be instituted in any court of competent jurisdiction in the location in which the work or part of the work is located and shall be instituted within two years after a declaration of Contractor Default or within two years after the Contractor ceased working or within two years after the Surety refuses or fails to perform its obligations under this Bond, whichever occurs first. If the provisions of this Paragraph are void or prohibited by law, the minimum period of limitation available to sureties as a defense in the jurisdiction of the suit shall be applicable.

§ 12 Notice to the Surety, the Owner or the Contractor shall be mailed or delivered to the address shown on the page on which their signature appears.

§ 13 When this Bond has been furnished to comply with a statutory or other legal requirement in the location where the construction was to be performed, any provision in this Bond conflicting with said statutory or legal requirement shall be deemed deleted herefrom and provisions conforming to such statutory or other legal requirement shall be deemed incorporated herein. When so furnished, the intent is that this Bond shall be construed as a statutory bond and not as a common law bond.

#### § 14 Definitions

§ 14.1 **Balance of the Contract Price.** The total amount payable by the Owner to the Contractor under the Construction Contract after all proper adjustments have been made, including allowance to the Contractor of any amounts received or to be received by the Owner in settlement of insurance or other claims for damages to which the Contractor is entitled, reduced by all valid and proper payments made to or on behalf of the Contractor under the Construction Contract.

§ 14.2 **Construction Contract.** The agreement between the Owner and Contractor identified on the cover page, including all Contract Documents and changes made to the agreement and the Contract Documents.

§ 14.3 **Contractor Default.** Failure of the Contractor, which has not been remedied or waived, to perform or otherwise to comply with a material term of the Construction Contract.

§ 14.4 **Owner Default.** Failure of the Owner, which has not been remedied or waived, to pay the Contractor as required under the Construction Contract or to perform and complete or comply with the other material terms of the Construction Contract.

§ 14.5 **Contract Documents.** All the documents that comprise the agreement between the Owner and Contractor.

Init.

§ 15 If this Bond is issued for an agreement between a Contractor and subcontractor, the term Contractor in this Bond shall be deemed to be Subcontractor and the term Owner shall be deemed to be Contractor.

§ 16 Modifications to this bond are as follows:

*(Space is provided below for additional signatures of added parties, other than those appearing on the cover page.)*

**CONTRACTOR AS PRINCIPAL**

**SURETY**

Company: \_\_\_\_\_  
*(Corporate Seal)*

Company: \_\_\_\_\_  
*(Corporate Seal)*

Signature: \_\_\_\_\_

Signature: \_\_\_\_\_

Name and Title: \_\_\_\_\_

Name and Title: \_\_\_\_\_

Address: \_\_\_\_\_

Address: \_\_\_\_\_

Init.



 **AIA**® Document A312™ – 2010

**Payment Bond**

**CONTRACTOR:**  
*(Name, legal status and address)*

**SURETY:**  
*(Name, legal status and principal place of business)*

**OWNER:**  
*(Name, legal status and address)*

**CONSTRUCTION CONTRACT**

Date:  
Amount: \$  
Description:  
*(Name and location)*

**BOND**

Date:  
*(Not earlier than Construction Contract Date)*

Amount: \$  
Modifications to this Bond:  None  See Section 18

**CONTRACTOR AS PRINCIPAL**

Company: *(Corporate Seal)*

**SURETY**

Company: *(Corporate Seal)*

Signature: \_\_\_\_\_  
Name and  
Title:

Signature: \_\_\_\_\_  
Name and  
Title:

*(Any additional signatures appear on the last page of this Payment Bond.)*

*(FOR INFORMATION ONLY — Name, address and telephone)*

**AGENT or BROKER:**

**OWNER'S REPRESENTATIVE:**  
*(Architect, Engineer or other party:)*

**ADDITIONS AND DELETIONS:**

The author of this document has added information needed for its completion. The author may also have revised the text of the original AIA standard form. An *Additions and Deletions Report* that notes added information as well as revisions to the standard form text is available from the author and should be reviewed. A vertical line in the left margin of this document indicates where the author has added necessary information and where the author has added to or deleted from the original AIA text.

This document has important legal consequences. Consultation with an attorney is encouraged with respect to its completion or modification.

Any singular reference to Contractor, Surety, Owner or other party shall be considered plural where applicable.

Init.

§ 1 The Contractor and Surety, jointly and severally, bind themselves, their heirs, executors, administrators, successors and assigns to the Owner to pay for labor, materials and equipment furnished for use in the performance of the Construction Contract, which is incorporated herein by reference, subject to the following terms.

§ 2 If the Contractor promptly makes payment of all sums due to Claimants, and defends, indemnifies and holds harmless the Owner from claims, demands, liens or suits by any person or entity seeking payment for labor, materials or equipment furnished for use in the performance of the Construction Contract, then the Surety and the Contractor shall have no obligation under this Bond.

§ 3 If there is no Owner Default under the Construction Contract, the Surety's obligation to the Owner under this Bond shall arise after the Owner has promptly notified the Contractor and the Surety (at the address described in Section 13) of claims, demands, liens or suits against the Owner or the Owner's property by any person or entity seeking payment for labor, materials or equipment furnished for use in the performance of the Construction Contract and tendered defense of such claims, demands, liens or suits to the Contractor and the Surety.

§ 4 When the Owner has satisfied the conditions in Section 3, the Surety shall promptly and at the Surety's expense defend, indemnify and hold harmless the Owner against a duly tendered claim, demand, lien or suit.

§ 5 The Surety's obligations to a Claimant under this Bond shall arise after the following:

§ 5.1 Claimants, who do not have a direct contract with the Contractor,

- .1 have furnished a written notice of non-payment to the Contractor, stating with substantial accuracy the amount claimed and the name of the party to whom the materials were, or equipment was, furnished or supplied or for whom the labor was done or performed, within ninety (90) days after having last performed labor or last furnished materials or equipment included in the Claim; and
- .2 have sent a Claim to the Surety (at the address described in Section 13).

§ 5.2 Claimants, who are employed by or have a direct contract with the Contractor, have sent a Claim to the Surety (at the address described in Section 13).

§ 6 If a notice of non-payment required by Section 5.1.1 is given by the Owner to the Contractor, that is sufficient to satisfy a Claimant's obligation to furnish a written notice of non-payment under Section 5.1.1.

§ 7 When a Claimant has satisfied the conditions of Sections 5.1 or 5.2, whichever is applicable, the Surety shall promptly and at the Surety's expense take the following actions:

§ 7.1 Send an answer to the Claimant, with a copy to the Owner, within sixty (60) days after receipt of the Claim, stating the amounts that are undisputed and the basis for challenging any amounts that are disputed; and

§ 7.2 Pay or arrange for payment of any undisputed amounts.

§ 7.3 The Surety's failure to discharge its obligations under Section 7.1 or Section 7.2 shall not be deemed to constitute a waiver of defenses the Surety or Contractor may have or acquire as to a Claim, except as to undisputed amounts for which the Surety and Claimant have reached agreement. If, however, the Surety fails to discharge its obligations under Section 7.1 or Section 7.2, the Surety shall indemnify the Claimant for the reasonable attorney's fees the Claimant incurs thereafter to recover any sums found to be due and owing to the Claimant.

§ 8 The Surety's total obligation shall not exceed the amount of this Bond, plus the amount of reasonable attorney's fees provided under Section 7.3, and the amount of this Bond shall be credited for any payments made in good faith by the Surety.

§ 9 Amounts owed by the Owner to the Contractor under the Construction Contract shall be used for the performance of the Construction Contract and to satisfy claims, if any, under any construction performance bond. By the Contractor furnishing and the Owner accepting this Bond, they agree that all funds earned by the Contractor in the performance of the Construction Contract are dedicated to satisfy obligations of the Contractor and Surety under this Bond, subject to the Owner's priority to use the funds for the completion of the work.



§ 10 The Surety shall not be liable to the Owner, Claimants or others for obligations of the Contractor that are unrelated to the Construction Contract. The Owner shall not be liable for the payment of any costs or expenses of any Claimant under this Bond, and shall have under this Bond no obligation to make payments to, or give notice on behalf of, Claimants or otherwise have any obligations to Claimants under this Bond.

§ 11 The Surety hereby waives notice of any change, including changes of time, to the Construction Contract or to related subcontracts, purchase orders and other obligations.

§ 12 No suit or action shall be commenced by a Claimant under this Bond other than in a court of competent jurisdiction in the state in which the project that is the subject of the Construction Contract is located or after the expiration of one year from the date (1) on which the Claimant sent a Claim to the Surety pursuant to Section 5.1.2 or 5.2, or (2) on which the last labor or service was performed by anyone or the last materials or equipment were furnished by anyone under the Construction Contract, whichever of (1) or (2) first occurs. If the provisions of this Paragraph are void or prohibited by law, the minimum period of limitation available to sureties as a defense in the jurisdiction of the suit shall be applicable.

§ 13 Notice and Claims to the Surety, the Owner or the Contractor shall be mailed or delivered to the address shown on the page on which their signature appears. Actual receipt of notice or Claims, however accomplished, shall be sufficient compliance as of the date received.

§ 14 When this Bond has been furnished to comply with a statutory or other legal requirement in the location where the construction was to be performed, any provision in this Bond conflicting with said statutory or legal requirement shall be deemed deleted herefrom and provisions conforming to such statutory or other legal requirement shall be deemed incorporated herein. When so furnished, the intent is that this Bond shall be construed as a statutory bond and not as a common law bond.

§ 15 Upon request by any person or entity appearing to be a potential beneficiary of this Bond, the Contractor and Owner shall promptly furnish a copy of this Bond or shall permit a copy to be made.

#### § 16 Definitions

§ 16.1 Claim. A written statement by the Claimant including at a minimum:

- .1 the name of the Claimant;
- .2 the name of the person for whom the labor was done, or materials or equipment furnished;
- .3 a copy of the agreement or purchase order pursuant to which labor, materials or equipment was furnished for use in the performance of the Construction Contract;
- .4 a brief description of the labor, materials or equipment furnished;
- .5 the date on which the Claimant last performed labor or last furnished materials or equipment for use in the performance of the Construction Contract;
- .6 the total amount earned by the Claimant for labor, materials or equipment furnished as of the date of the Claim;
- .7 the total amount of previous payments received by the Claimant; and
- .8 the total amount due and unpaid to the Claimant for labor, materials or equipment furnished as of the date of the Claim.

§ 16.2 Claimant. An individual or entity having a direct contract with the Contractor or with a subcontractor of the Contractor to furnish labor, materials or equipment for use in the performance of the Construction Contract. The term Claimant also includes any individual or entity that has rightfully asserted a claim under an applicable mechanic's lien or similar statute against the real property upon which the Project is located. The intent of this Bond shall be to include without limitation in the terms "labor, materials or equipment" that part of water, gas, power, light, heat, oil, gasoline, telephone service or rental equipment used in the Construction Contract, architectural and engineering services required for performance of the work of the Contractor and the Contractor's subcontractors, and all other items for which a mechanic's lien may be asserted in the jurisdiction where the labor, materials or equipment were furnished.

§ 16.3 Construction Contract. The agreement between the Owner and Contractor identified on the cover page, including all Contract Documents and all changes made to the agreement and the Contract Documents.

§ 16.4 **Owner Default.** Failure of the Owner, which has not been remedied or waived, to pay the Contractor as required under the Construction Contract or to perform and complete or comply with the other material terms of the Construction Contract.

§ 16.5 **Contract Documents.** All the documents that comprise the agreement between the Owner and Contractor.

§ 17 If this Bond is issued for an agreement between a Contractor and subcontractor, the term Contractor in this Bond shall be deemed to be Subcontractor and the term Owner shall be deemed to be Contractor.

§ 18 Modifications to this bond are as follows:

*(Space is provided below for additional signatures of added parties, other than those appearing on the cover page.)*

**CONTRACTOR AS PRINCIPAL**

**SURETY**

Company: \_\_\_\_\_  
*(Corporate Seal)*

Company: \_\_\_\_\_  
*(Corporate Seal)*

Signature: \_\_\_\_\_  
Name and Title: \_\_\_\_\_  
Address: \_\_\_\_\_

Signature: \_\_\_\_\_  
Name and Title: \_\_\_\_\_  
Address: \_\_\_\_\_



Project: Roof Replacemnt Stratford Academy

2) Boilermaker	38.34	26.01
3a) Bricklayer, Cement Mason, Concrete Finisher (including caulking), Stone Masons	34.72	32.55 + a
3b) Tile Setter	34.90	25.87
3c) Terrazzo Mechanics and Marble Setters	31.69	22.35
3d) Tile, Marble & Terrazzo Finishers	26.70	21.75
3e) Plasterer	33.48	32.06

**As of: Wednesday, May 29, 2019**



Project: Roof Replacemnt Stratford Academy

-----LABORERS-----

4) Group 1: Laborers (common or general), acetylene burners, concrete specialists, wrecking laborers, fire watchers.	30.75	20.84
4a) Group 2: Mortar mixers, plaster tender, power buggy operators, powdermen, fireproofers/mixer/nozzleman (Person running mixer and spraying fireproof only).	30.30	20.10
4b) Group 3: Jackhammer operators/pavement breaker, mason tender (brick), mason tender (cement/concrete), forklift operators and forklift operators (masonry).	31.25	20.84
4c) **Group 4: Pipelayers (Installation of water, storm drainage or sewage lines outside of the building line with P6, P7 license) (the pipelayer rate shall apply only to one or two employees of the total crew who primary task is to actually perform the mating of pipe sections) P6 and P7 rate is \$26.80.	30.55	20.10
4d) Group 5: Air track operator, sand blaster and hydraulic drills.	30.55	20.10

**As of: Wednesday, May 29, 2019**

Project: Roof Replacemnt Stratford Academy

4e) Group 6: Blasters, nuclear and toxic waste removal.	31.80	20.10
4f) Group 7: Asbestos/lead removal and encapsulation (except it's removal from mechanical systems which are not to be scrapped).	31.05	20.10
4g) Group 8: Bottom men on open air caisson, cylindrical work and boring crew.	28.38	20.10
4h) Group 9: Top men on open air caisson, cylindrical work and boring crew.	27.86	20.10
4i) Group 10: Traffic Control Signalman	16.00	20.10
5) Carpenter, Acoustical Ceiling Installation, Soft Floor/Vinyl Floor/Carpet Laying, Metal Stud Installation, Form Work and Scaffold Building, Drywall Hanging, Modular-Furniture Systems Installers, Lathers, Piledrivers, Resilient Floor Layers.	33.53	25.66

**As of: Wednesday, May 29, 2019**

Project: Roof Replacemnt Stratford Academy

5a) Millwrights	34.04	26.09
6) Electrical Worker (including low voltage wiring) (Trade License required: E1,2 L-5,6 C-5,6 T-1,2 L-1,2 V-1,2,7,8,9)	38.82	26.25+3% of gross wage
7a) Elevator Mechanic (Trade License required: R-1,2,5,6)	53.37	33.705+a+b

-----LINE CONSTRUCTION-----

Groundman	26.50	6.5% + 9.00
Linemen/Cable Splicer	48.19	6.5% + 22.00

**As of: Wednesday, May 29, 2019**

Project: Roof Replacemnt Stratford Academy

8) Glazier (Trade License required: FG-1,2)	37.18	21.05 + a
---	-------	-----------

9) Ironworker, Ornamental, Reinforcing, Structural, and Precast Concrete Erection	35.47	35.14 + a
---	-------	-----------

----OPERATORS----

Group 1: Crane handling or erecting structural steel or stone, hoisting engineer 2 drums or over, front end loader (7 cubic yards or over), work boat 26 ft. and over and Tunnel Boring Machines. (Trade License Required)	40.97	24.80 + a
--	-------	-----------

Group 2: Cranes (100 ton rate capacity and over); Excavator over 2 cubic yards; Piledriver (\$3.00 premium when operator controls hammer); Bauer Drill/Caisson. (Trade License Required)	40.64	24.80 + a
--	-------	-----------

Group 3: Excavator; Backhoe/Excavator under 2 cubic yards; Cranes (under 100 ton rated capacity), Grader/Blade; Master Mechanic; Hoisting Engineer (all types of equipment where a drum and cable are used to hoist or drag material regardless of motive power of operation), Rubber Tire Excavator (Drott-1085 or similar); Grader Operator; Bulldozer Fine Grade. (slopes, shaping, laser or GPS, etc.). (Trade License Required)	39.88	24.80 + a
--	-------	-----------

**As of: Wednesday, May 29, 2019**

Project: Roof Replacemnt Stratford Academy

Group 4: Trenching Machines; Lighter Derrick; Concrete Finishing Machine; CMI Machine or Similar; Koehring Loader (Skooper).	39.48	24.80 + a
Group 5: Specialty Railroad Equipment; Asphalt Paver; Asphalt Reclaiming Machine; Line Grinder; Concrete Pumps; Drills with Self Contained Power Units; Boring Machine; Post Hole Digger; Auger; Pounder; Well Digger; Milling Machine (over 24" Mandrell)	38.87	24.80 + a
Group 5 continued: Side Boom; Combination Hoe and Loader; Directional Driller; Pile Testing Machine.	38.87	24.80 + a
Group 6: Front End Loader (3 up to 7 cubic yards); Bulldozer (rough grade dozer).	38.55	24.80 + a
Group 7: Asphalt roller, concrete saws and cutters (ride on types), vermeer concrete cutter, Stump Grinder; Scraper; Snooper; Skidder; Milling Machine (24" and under Mandrell).	38.20	24.80 + a
Group 8: Mechanic, grease truck operator, hydroblaster; barrier mover; power stone spreader; welding; work boat under 26 ft.; transfer machine.	37.79	24.80 + a

**As of: Wednesday, May 29, 2019**

Project: Roof Replacemnt Stratford Academy

Group 9: Front end loader (under 3 cubic yards), skid steer loader regardless of attachments, (Bobcat or Similar): forklift, power chipper; landscape equipment (including Hydroseeder).	37.34	24.80 + a
Group 10: Vibratory hammer; ice machine; diesel and air, hammer, etc.	35.24	24.80 + a
Group 11: Conveyor, earth roller, power pavement breaker (whiphammer), robot demolition equipment.	35.24	24.80 + a
Group 12: Wellpoint operator.	35.18	24.80 + a
Group 13: Compressor battery operator.	34.58	24.80 + a
Group 14: Elevator operator; tow motor operator (solid tire no rough terrain).	33.41	24.80 + a

**As of: Wednesday, May 29, 2019**

Project: Roof Replacemnt Stratford Academy

Group 15: Generator Operator; Compressor Operator; Pump Operator; Welding Machine Operator; Heater Operator.	32.99	24.80 + a
--	-------	-----------

Group 16: Maintenance Engineer/Oiler.	32.32	24.80 + a
---------------------------------------	-------	-----------

Group 17: Portable asphalt plant operator; portable crusher plant operator; portable concrete plant operator.	36.76	24.80 + a
---	-------	-----------

Group 18: Power safety boat; vacuum truck; zim mixer; sweeper; (Minimum for any job requiring a CDL license).	34.26	24.80 + a
---	-------	-----------

-----PAINTERS (Including Drywall Finishing)-----

10a) Brush and Roller	33.62	21.05
-----------------------	-------	-------

**As of: Wednesday, May 29, 2019**

Project: Roof Replacemnt Stratford Academy

10b) Taping Only/Drywall Finishing	34.37	21.05
10c) Paperhanger and Red Label	34.12	21.05
10e) Blast and Spray	36.62	21.05
11) Plumber (excluding HVAC pipe installation) (Trade License required: P-1,2,6,7,8,9 J-1,2,3,4 SP-1,2)	42.62	31.21
12) Well Digger, Pile Testing Machine	37.26	24.05 + a
Rofer: Cole Tar Pitch	41.50	17.00 + a

**As of: Wednesday, May 29, 2019**



Project: Roof Replacemnt Stratford Academy

Rofer: Slate, Tile, Composition, Shingles, Singly Ply and Damp/Waterproofing	40.00	17.00 + a
--	-------	-----------

15) Sheetmetal Worker (Trade License required for HVAC and Ductwork: SM-1,SM-2,SM-3,SM-4,SM-5,SM-6)	43.70	42.40
---	-------	-------

16) Pipefitter (Including HVAC work) License required: S-1,2,3,4,5,6,7,8 B-1,2,3,4 D-1,2,3,4, G-1, G-2, G-8 & G-9)	(Trade	42.62	31.21
---	--------	-------	-------

-----TRUCK DRIVERS-----

17a) 2 Axle	29.13	23.33 + a
-------------	-------	-----------

17b) 3 Axle, 2 Axle Ready Mix	29.23	23.33 + a
-------------------------------	-------	-----------

**As of: Wednesday, May 29, 2019**

Project: Roof Replacemnt Stratford Academy

17c) 3 Axle Ready Mix	29.28	23.33 + a
17d) 4 Axle, Heavy Duty Trailer up to 40 tons	29.33	23.33 + a
17e) 4 Axle Ready Mix	29.38	23.33 + a
17f) Heavy Duty Trailer (40 Tons and Over)	29.58	23.33 + a
17g) Specialized Earth Moving Equipment (Other Than Conventional Type on-the-Road Trucks and Semi-Trailers, Including Euclids)	29.38	23.33 + a
18) Sprinkler Fitter (Trade License required: F-1,2,3,4)	43.92	15.84 + a

**As of: Wednesday, May 29, 2019**

Project: Roof Replacemnt Stratford Academy

19) Theatrical Stage Journeyman

25.76

7.34

***As of: Wednesday, May 29, 2019***

**Project: Roof Replacemnt Stratford Academy**

*Welders: Rate for craft to which welding is incidental.*

*\*Note: Hazardous waste removal work receives additional \$1.25 per hour for truck drivers.*

*\*\*Note: Hazardous waste premium \$3.00 per hour over classified rate*

***ALL Cranes: When crane operator is operating equipment that requires a fully licensed crane operator to operate he receives an extra \$4.00 premium in addition to the hourly wage rate and benefit contributions:***

***1) Crane handling or erecting structural steel or stone; hoisting engineer (2 drums or over)***

***2) Cranes (100 ton rate capacity and over) Bauer Drill/Caisson***

***3) Cranes (under 100 ton rated capacity)***

*Crane with 150 ft. boom (including jib) - \$1.50 extra*

*Crane with 200 ft. boom (including jib) - \$2.50 extra*

*Crane with 250 ft. boom (including jib) - \$5.00 extra*

*Crane with 300 ft. boom (including jib) - \$7.00 extra*

*Crane with 400 ft. boom (including jib) - \$10.00 extra*

All classifications that indicate a percentage of the fringe benefits must be calculated at the percentage rate times the "base hourly rate".

Apprentices duly registered under the Commissioner of Labor's regulations on "Work Training Standards for Apprenticeship and Training Programs" Section 31-51-d-1 to 12, are allowed to be paid the appropriate percentage of the prevailing journeymen hourly base and the full fringe benefit rate, providing the work site ratio shall not be less than one full-time journeyman instructing and supervising the work of each apprentice in a specific trade.

*The Prevailing wage rates applicable to this project are subject to annual adjustments each July 1st for the duration of the project.*

*Each contractor shall pay the annual adjusted prevailing wage rate that is in effect each July 1st, as posted by the Department of Labor.*

*It is the contractor's responsibility to obtain the annual adjusted prevailing wage rate increases directly from the Department of Labor's website.*

*The annual adjustments will be posted on the Department of Labor's Web page: [www.ct.gov/dol](http://www.ct.gov/dol). For those without internet access, please contact the division listed below.*

*The Department of Labor will continue to issue the initial prevailing wage rate schedule to the Contracting Agency for the project.*

*All subsequent annual adjustments will be posted on our Web Site for contractor access.*

*Contracting Agencies are under no obligation pursuant to State labor law to pay any increase due to the annual adjustment provision.*

**As of: Wednesday, May 29, 2019**

Project: Roof Replacemnt Stratford Academy

*Effective October 1, 2005 - Public Act 05-50: any person performing the work of any mechanic, laborer, or worker shall be paid prevailing wage*

All Person who perform work ON SITE must be paid prevailing wage for the appropriate mechanic, laborer, or worker classification.

All certified payrolls must list the hours worked and wages paid to All Persons who perform work ON SITE regardless of their ownership i.e.: (Owners, Corporate Officers, LLC Members, Independent Contractors, et. al)

Reporting and payment of wages is required regardless of any contractual relationship alleged to exist between the contractor and such person.

**~~Unlisted classifications needed for work not included within the scope of the classifications listed may be added after award only as provided in the labor standards contract clause (29 CFR 5.5 (a) (1) (ii)).**

Please direct any questions which you may have pertaining to classification of work and payment of prevailing wages to the Wage and Workplace Standards Division, telephone (860)263-6790.

**As of: Wednesday, May 29, 2019**

**Sec. 31-53b. Construction safety and health course. New miner training program. Proof of completion required for mechanics, laborers and workers on public works projects. Enforcement. Regulations. Exceptions.** (a) Each contract for a public works project entered into on or after July 1, 2009, by the state or any of its agents, or by any political subdivision of the state or any of its agents, described in subsection (g) of section 31-53, shall contain a provision requiring that each contractor furnish proof with the weekly certified payroll form for the first week each employee begins work on such project that any person performing the work of a mechanic, laborer or worker pursuant to the classifications of labor under section 31-53 on such public works project, pursuant to such contract, has completed a course of at least ten hours in duration in construction safety and health approved by the federal Occupational Safety and Health Administration or, has completed a new miner training program approved by the Federal Mine Safety and Health Administration in accordance with 30 CFR 48 or, in the case of telecommunications employees, has completed at least ten hours of training in accordance with 29 CFR 1910.268.

(b) Any person required to complete a course or program under subsection (a) of this section who has not completed the course or program shall be subject to removal from the worksite if the person does not provide documentation of having completed such course or program by the fifteenth day after the date the person is found to be in noncompliance. The Labor Commissioner or said commissioner's designee shall enforce this section.

(c) Not later than January 1, 2009, the Labor Commissioner shall adopt regulations, in accordance with the provisions of chapter 54, to implement the provisions of subsections (a) and (b) of this section. Such regulations shall require that the ten-hour construction safety and health courses required under subsection (a) of this section be conducted in accordance with federal Occupational Safety and Health Administration Training Institute standards, or in accordance with Federal Mine Safety and Health Administration Standards or in accordance with 29 CFR 1910.268, as appropriate. The Labor Commissioner shall accept as sufficient proof of compliance with the provisions of subsection (a) or (b) of this section a student course completion card issued by the federal Occupational Safety and Health Administration Training Institute, or such other proof of compliance said commissioner deems appropriate, dated no earlier than five years before the commencement date of such public works project.

(d) This section shall not apply to employees of public service companies, as defined in section 16-1, or drivers of commercial motor vehicles driving the vehicle on the public works project and delivering or picking up cargo from public works projects provided they perform no labor relating to the project other than the loading and unloading of their cargo.

(P.A. 06-175, S. 1; P.A. 08-83, S. 1.)

History: P.A. 08-83 amended Subsec. (a) by making provisions applicable to public works project contracts entered into on or after July 1, 2009, replacing provision re total cost of work with reference to Sec. 31-53(g), requiring proof in certified payroll form that new mechanic, laborer or worker has completed a 10-hour or more construction safety course and adding provision re new miner training program, amended Subsec. (b) by substituting "person" for "employee" and adding "or program", amended Subsec. (c) by adding "or in accordance with Federal Mine Safety and Health Administration Standards" and setting new deadline of January 1, 2009, deleted former Subsec. (d) re "public building", added new Subsec. (d) re exemptions for public service company employees and delivery drivers who perform no labor other than delivery and made conforming and technical changes, effective January 1, 2009.

# **Informational Bulletin**

## **THE 10-HOUR OSHA CONSTRUCTION SAFETY AND HEALTH COURSE**

(applicable to public building contracts entered into *on or after July 1, 2007*, where the total cost of all work to be performed is at least \$100,000)

- (1) This requirement was created by Public Act No. 06-175, which is codified in Section 31-53b of the Connecticut General Statutes (pertaining to the prevailing wage statutes);
- (2) The course is required for public building construction contracts (projects funded in whole or in part by the state or any political subdivision of the state) entered into on or after July 1, 2007;
- (3) It is required of private employees (not state or municipal employees) and apprentices who perform manual labor for a general contractor or subcontractor on a public building project where the total cost of all work to be performed is at least \$100,000;
- (4) The ten-hour construction course pertains to the ten-hour Outreach Course conducted in accordance with federal OSHA Training Institute standards, and, for telecommunications workers, a ten-hour training course conducted in accordance with federal OSHA standard, 29 CFR 1910.268;
- (5) The internet website for the federal OSHA Training Institute is [http://www.osha.gov/fso/ote/training/edcenters/fact\\_sheet.html](http://www.osha.gov/fso/ote/training/edcenters/fact_sheet.html);
- (6) The statutory language leaves it to the contractor and its employees to determine who pays for the cost of the ten-hour Outreach Course;
- (7) Within 30 days of receiving a contract award, a general contractor must furnish proof to the Labor Commissioner that all employees and apprentices performing manual labor on the project will have completed such a course;
- (8) Proof of completion may be demonstrated through either: (a) the presentation of a *bona fide* student course completion card issued by the federal OSHA Training Institute; *or* (2) the presentation of documentation provided to an employee by a trainer certified by the Institute pending the actual issuance of the completion card;
- (9) Any card with an issuance date more than 5 years prior to the commencement date of the construction project shall not constitute proof of compliance;



- (10) Each employer shall affix a copy of the construction safety course completion card to the certified payroll submitted to the contracting agency in accordance with Conn. Gen. Stat. § 31-53(f) on which such employee's name first appears;
- (11) Any employee found to be in non-compliance shall be subject to removal from the worksite if such employee does not provide satisfactory proof of course completion to the Labor Commissioner by the fifteenth day after the date the employee is determined to be in noncompliance;
- (12) Any such employee who is determined to be in noncompliance may continue to work on a public building construction project for a maximum of fourteen consecutive calendar days while bringing his or her status into compliance;
- (13) The Labor Commissioner may make complaint to the prosecuting authorities regarding any employer or agent of the employer, or officer or agent of the corporation who files a false certified payroll with respect to the status of an employee who is performing manual labor on a public building construction project;
- (14) The statute provides the minimum standards required for the completion of a safety course by manual laborers on public construction contracts; any contractor can exceed these minimum requirements; and
- (15) Regulations clarifying the statute are currently in the regulatory process, and shall be posted on the CTDOL website as soon as they are adopted in final form.
- (16) Any questions regarding this statute may be directed to the Wage and Workplace Standards Division of the Connecticut Labor Department via the internet website of <http://www.ctdol.state.ct.us/wgwkstnd/wgemenu.htm>; or by telephone at (860)263-6790.

**THE ABOVE INFORMATION IS PROVIDED EXCLUSIVELY AS AN EDUCATIONAL RESOURCE, AND IS NOT INTENDED AS A SUBSTITUTE FOR LEGAL INTERPRETATIONS WHICH MAY ULTIMATELY ARISE CONCERNING THE CONSTRUCTION OF THE STATUTE OR THE REGULATIONS.**

## Statute 31-55a

You are here: [DOL Web Site](#) ▶ [Wage and Workplace Standards](#) ▶ Statute 31-55a

### - Special Notice -

#### To All State and Political Subdivisions, Their Agents, and Contractors

#### Connecticut General Statute 31-55a - Annual adjustments to wage rates by contractors doing state work.

*Each contractor that is awarded a contract on or after October 1, 2002, for (1) the construction of a state highway or bridge that falls under the provisions of section 31-54 of the general statutes, or (2) the construction, remodeling, refinishing, refurbishing, rehabilitation, alteration or repair of any public works project that falls under the provisions of section 31-53 of the general statutes shall contact the Labor Commissioner on or before July first of each year, for the duration of such contract, to ascertain the prevailing rate of wages on an hourly basis and the amount of payment or contributions paid or payable on behalf of each mechanic, laborer or worker employed upon the work contracted to be done, and shall make any necessary adjustments to such prevailing rate of wages and such payment or contributions paid or payable on behalf of each such employee, effective each July first.*

- The prevailing wage rates applicable to any contract or subcontract awarded on or after October 1, 2002 are subject to annual adjustments each July 1st for the duration of any project which was originally advertised for bids on or after October 1, 2002.
- Each contractor affected by the above requirement shall pay the annual adjusted prevailing wage rate that is in effect each July 1st, as posted by the Department of Labor.
- It is the **contractor's** responsibility to obtain the annual adjusted prevailing wage rate increases directly from the Department of Labor's Web Site. The annual adjustments will be posted on the Department of Labor Web page: [www.ctdol.state.ct.us](http://www.ctdol.state.ct.us). For those without internet access, please contact the division listed below.
- The Department of Labor will continue to issue the initial prevailing wage rate schedule to the Contracting Agency for the project. All subsequent annual adjustments will be posted on our Web Site for contractor access.

**Any questions should be directed to the Contract Compliance Unit, Wage and Workplace Standards Division, Connecticut Department of Labor, 200 Folly Brook Blvd., Wethersfield, CT 06109 at (860)263-6790.**

← -- [Workplace Laws](#)

Published by the Connecticut Department of Labor, Project Management Office  
Last Updated: April 22, 2010

CONNECTICUT DEPARTMENT OF LABOR  
WAGE AND WORKPLACE STANDARDS DIVISION

CONTRACTORS WAGE CERTIFICATION FORM

I, \_\_\_\_\_ of \_\_\_\_\_  
Officer, Owner, Authorized Rep. Company Name

do hereby certify that the \_\_\_\_\_  
Company Name  
\_\_\_\_\_  
Street  
\_\_\_\_\_  
City

and all of its subcontractors will pay all workers on the

\_\_\_\_\_  
Project Name and Number  
\_\_\_\_\_  
Street and City

the wages as listed in the schedule of prevailing rates required for such project (a copy of which is attached hereto).

\_\_\_\_\_  
Signed

Subscribed and sworn to before me this \_\_\_\_\_ day of \_\_\_\_\_, \_\_\_\_\_.

\_\_\_\_\_  
Notary Public

Return to:  
Connecticut Department of Labor  
Wage & Workplace Standards Division  
200 Folly Brook Blvd.  
Wethersfield, CT 06109

Rate Schedule Issued (Date): \_\_\_\_\_

[New] In accordance with Section 31-53b(a) of the C.G.S. each contractor shall provide a copy of the OSHA 10 Hour Construction Safety and Health Card for each employee, to be attached to the first certified payroll on the project.

In accordance with Connecticut General Statutes, 31-53 Certified Payrolls with a statement of compliance shall be submitted monthly to the contracting agency.											<b>PAYROLL CERTIFICATION FOR PUBLIC WORKS PROJECTS</b>							Connecticut Department of Labor Wage and Workplace Standards Division 200 Folly Brook Blvd. Wethersfield, CT 06109									
CONTRACTOR NAME AND ADDRESS:											SUBCONTRACTOR NAME & ADDRESS							WORKER'S COMPENSATION INSURANCE CARRIER									
PAYROLL NUMBER	Week-Ending Date	PROJECT NAME & ADDRESS											POLICY #					EFFECTIVE DATE:					EXPIRATION DATE:				
PERSON/WORKER, ADDRESS and SECTION	APPR RATE %	MALE/ FEMALE AND RACE*	WORK CLASSIFICATION  Trade License Type & Number - OSHA 10 Certification Number	DAY AND DATE							Total ST Hours	BASE HOURLY RATE	TOTAL FRINGE BENEFIT PLAN CASH	TYPE OF FRINGE BENEFITS Per Hour 1 through 6 (see back)	GROSS PAY FOR ALL WORK PERFORMED THIS WEEK	TOTAL DEDUCTIONS				GROSS PAY FOR THIS PREVAILING RATE JOB	CHECK # AND NET PAY						
				S	M	T	W	TH	F	S						FICA	FEDERAL WITH- HOLDING	STATE WITH- HOLDING	LIST OTHER								
				HOURS WORKED EACH DAY							Total O/T Hours																
												\$	1. \$														
												\$	2. \$														
												Base Rate	3. \$														
												\$	4. \$														
												\$	5. \$														
												Cash Fringe	6. \$														

7/13/2009 \*IF REQUIRED  
WWS-CPI

\*SEE REVERSE SIDE

PAGE NUMBER \_\_\_\_ OF

**\*FRINGE BENEFITS EXPLANATION (P):**

Bona fide benefits paid to approved plans, funds or programs, except those required by Federal or State Law (unemployment tax, worker’s compensation, income taxes, etc.).

Please specify the type of benefits provided:

- 1) Medical or hospital care \_\_\_\_\_ 4) Disability \_\_\_\_\_
- 2) Pension or retirement \_\_\_\_\_ 5) Vacation, holiday \_\_\_\_\_
- 3) Life Insurance \_\_\_\_\_ 6) Other (please specify) \_\_\_\_\_

**CERTIFIED STATEMENT OF COMPLIANCE**

For the week ending date of \_\_\_\_\_,

I, \_\_\_\_\_ of \_\_\_\_\_, (hereafter known as Employer) in my capacity as \_\_\_\_\_ (title) do hereby certify and state:

**Section A:**

1. All persons employed on said project have been paid the full weekly wages earned by them during the week in accordance with Connecticut General Statutes, section 31-53, as amended. Further, I hereby certify and state the following:

- a) The records submitted are true and accurate;
- b) The rate of wages paid to each mechanic, laborer or workman and the amount of payment or contributions paid or payable on behalf of each such employee to any employee welfare fund, as defined in Connecticut General Statutes, section 31-53 (h), are not less than the prevailing rate of wages and the amount of payment or contributions paid or payable on behalf of each such employee to any employee welfare fund, as determined by the Labor Commissioner pursuant to subsection Connecticut General Statutes, section 31-53 (d), and said wages and benefits are not less than those which may also be required by contract;
- c) The Employer has complied with all of the provisions in Connecticut General Statutes, section 31-53 (and Section 31-54 if applicable for state highway construction);
- d) Each such employee of the Employer is covered by a worker’s compensation insurance policy for the duration of his employment which proof of coverage has been provided to the contracting agency;
- e) The Employer does not receive kickbacks, which means any money, fee, commission, credit, gift, gratuity, thing of value, or compensation of any kind which is provided directly or indirectly, to any prime contractor, prime contractor employee, subcontractor, or subcontractor employee for the purpose of improperly obtaining or rewarding favorable treatment in connection with a prime contract or in connection with a prime contractor in connection with a subcontractor relating to a prime contractor; and
- f) The Employer is aware that filing a certified payroll which he knows to be false is a class D felony for which the employer may be fined up to five thousand dollars, imprisoned for up to five years or both.

2. OSHA~The employer shall affix a copy of the construction safety course, program or training completion document to the certified payroll required to be submitted to the contracting agency for this project on which such employee’s name first appears.

\_\_\_\_\_  
(Signature) (Title) Submitted on (Date)

**Section B: Applies to CONNDOT Projects ONLY**

**That pursuant to CONNDOT contract requirements for reporting purposes only, all employees listed under Section B who performed work on this project are not covered under the prevailing wage requirements defined in Connecticut General Statutes Section 31-53.**

\_\_\_\_\_  
(Signature) (Title) Submitted on (Date)

Note: CTDOL will assume all hours worked were performed under Section A unless clearly delineated as Section B WWS-CP1 as such. Should an employee perform work under both Section A and Section B, the hours worked and wages paid must be segregated for reporting purposes.

**\*\*\*THIS IS A PUBLIC DOCUMENT\*\*\*  
\*\*\*DO NOT INCLUDE SOCIAL SECURITY NUMBERS\*\*\***



## Information Bulletin

### *Occupational Classifications*

The Connecticut Department of Labor has the responsibility to properly determine "job classification" on prevailing wage projects covered under C.G.S. Section 31-53.

*Note: This information is intended to provide a sample of some occupational classifications for guidance purposes only. It is not an all-inclusive list of each occupation's duties. This list is being provided only to highlight some areas where a contractor may be unclear regarding the proper classification.*

**Below are additional clarifications of specific job duties performed for certain classifications:**

- **ASBESTOS WORKERS**

Applies all insulating materials, protective coverings, coatings and finishes to all types of mechanical systems.

- **ASBESTOS INSULATOR**

Handle, install apply, fabricate, distribute, prepare, alter, repair, dismantle, heat and frost insulation, including penetration and fire stopping work on all penetration fire stop systems.

- **BOILERMAKERS**

Erects hydro plants, incomplete vessels, steel stacks, storage tanks for water, fuel, etc. Builds incomplete boilers, repairs heat exchanges and steam generators.

- **BRICKLAYERS, CEMENT MASONS, CEMENT FINISHERS, MARBLE MASONS, PLASTERERS, STONE MASONS, PLASTERERS. STONE MASONS, TERRAZZO WORKERS, TILE SETTERS**

Lays building materials such as brick, structural tile and concrete cinder, glass, gypsum, terra cotta block. Cuts, tools and sets marble, sets stone, finishes concrete, applies decorative steel, aluminum and plastic tile, applies cements, sand, pigment and marble chips to floors, stairways, etc.

- **CARPENTERS, MILLWRIGHTS. PILEDIVERMEN. LATHERS. RESILIENT FLOOR LAYERS, DOCK BUILDERS, DIKERS, DIVER TENDERS**

Constructs, erects, installs and repairs structures and fixtures of wood, plywood and wallboard. Installs, assembles, dismantles, moves industrial machinery. Drives piling into ground to provide foundations for structures such as buildings and bridges, retaining walls for earth embankments, such as cofferdams. Fastens wooden, metal or rockboard lath to walls, ceilings and partitions of buildings, acoustical tile layer, concrete form builder. Applies firestopping materials on fire resistive joint systems only. Installation of curtain/window walls only where attached to wood or metal studs. Installation of insulated material of all types whether blown, nailed or attached in other ways to walls, ceilings and floors of buildings. Assembly and installation of modular furniture/furniture systems. Free-standing furniture is not covered. This includes free standing: student chairs, study top desks, book box desks, computer furniture, dictionary stand, atlas stand, wood shelving, two-position information access station, file cabinets, storage cabinets, tables, etc.

- **CLEANING LABORER**

The clean up of any construction debris and the general cleaning, including sweeping, wash down, mopping, wiping of the construction facility, washing, polishing, dusting, etc., prior to the issuance of a certificate of occupancy falls under the *Labor classification*.

- **DELIVERY PERSONNEL**

If delivery of supplies/building materials is to one common point and stockpiled there, prevailing wages are not required. If the delivery personnel are involved in the distribution of the material to multiple locations within the construction site then they would have to be paid prevailing wages for the type of work performed: laborer, equipment operator, electrician, ironworker, plumber, etc.

An example of this would be where delivery of drywall is made to a building and the delivery personnel distribute the drywall from one "stockpile" location to further sub-locations on each floor. Distribution of material around a construction site is the job of a laborer/tradesman and not a delivery personnel.

- **ELECTRICIANS**

Install, erect, maintenance, alteration or repair of any wire, cable, conduit, etc., which generates, transforms, transmits or uses electrical energy for light, heat, power or other purposes, including the Installation or maintenance of telecommunication, LAN wiring or computer equipment, and low voltage wiring.

**\*License required per Connecticut General Statutes: E-1,2 L-5,6 C-5,6 T-1,2 L-1,2 V-1,2,7,8,9.**



- **ELEVATOR CONSTRUCTORS**

Install, erect, maintenance and repair of all types of elevators, escalators, dumb waiters and moving walks. **\*License required by Connecticut General Statutes: R-1,2,5,6.**

- **FORK LIFT OPERATOR**

Laborers Group 4) Mason Tenders - operates forklift solely to assist a mason to a maximum height of nine (9) feet only.

Power Equipment Operator Group 9 - operates forklift to assist any trade, and to assist a mason to a height over nine (9) feet.

- **GLAZIERS**

Glazing wood and metal sash, doors, partitions, and 2 story aluminum storefronts. Installs glass windows, skylights, store fronts and display cases or surfaces such as building fronts, interior walls, ceilings and table tops and metal store fronts. Installation of aluminum window walls and curtain walls is the "joint" work of glaziers and ironworkers which requires either a blended rate or equal composite workforce.

- **IRONWORKERS**

Erection, installation and placement of structural steel, precast concrete, miscellaneous iron, ornamental iron, metal curtain wall, rigging and reinforcing steel. Handling, sorting, and installation of reinforcing steel (rebar). Metal bridge rail (traffic), metal bridge handrail, and decorative security fence installation. Installation of aluminum window walls and curtain walls is the "joint" work of glaziers and ironworkers which requires either a blended rate or equal composite workforce. Insulated metal and insulated composite panels are still installed by the Ironworker.

- **INSULATOR**

Installing fire stopping systems/materials for "Penetration Firestop Systems": transit to cables, electrical conduits, insulated pipes, sprinkler pipe penetrations, ductwork behind radiation, electrical cable trays, fire rated pipe penetrations, natural polypropylene, HVAC ducts, plumbing bare metal, telephone and communication wires, and boiler room ceilings. Past practice using the applicable licensed trades, Plumber, Sheet Metal, Sprinkler Fitter, and Electrician, is not inconsistent with the Insulator classification and would be permitted.

- **LABORERS**

Acetylene burners, asphalt rakers, chain saw operators, concrete and power buggy operator, concrete saw operator, fence and guard rail erector (except metal bridge rail (traffic), metal bridge handrail, and decorative security fence installation.), hand operated concrete vibrator operator, mason tenders, pipelayers (installation of storm drainage or sewage lines on the street only), pneumatic drill operator, pneumatic gas and electric drill operator, powermen and wagon drill operator, air track operator, block paver, curb setters, blasters, concrete spreaders.

- **PAINTERS**

Maintenance, preparation, cleaning, blasting (water and sand, etc.), painting or application of any protective coatings of every description on all bridges and appurtenances of highways, roadways, and railroads. Painting, decorating, hardwood finishing, paper hanging, sign writing, scenic art work and drywall hhg for any and all types of building and residential work.

- **LEAD PAINT REMOVAL**

Painter's Rate

1. Removal of lead paint from bridges.
2. Removal of lead paint as preparation of any surface to be repainted.
3. Where removal is on a Demolition project prior to reconstruction.

Laborer's Rate

1. Removal of lead paint from any surface NOT to be repainted.
2. Where removal is on a *TOTAL* Demolition project only.

- **PLUMBERS AND PIPEFITTERS**

Installation, repair, replacement, alteration or maintenance of all plumbing, heating, cooling and piping. ***\*License required per Connecticut General Statutes: P-1,2,6,7,8,9 J-1,2,3,4 SP-1,2 S-1,2,3,4,5,6,7,8 B-1,2,3,4 D-1,2,3,4.***

- **POWER EQUIPMENT OPERATORS**

Operates several types of power construction equipment such as compressors, pumps, hoists, derricks, cranes, shovels, tractors, scrapers or motor graders, etc. Repairs and maintains equipment. **\*License required, crane operators only, per Connecticut General Statutes.**

- **ROOFERS**

Covers roofs with composition shingles or sheets, wood shingles, slate or asphalt and gravel to waterproof roofs, including preparation of surface. (tear-off and/or removal of any type of roofing and/or clean-up of any and all areas where a roof is to be relaid)

- **SHEETMETAL WORKERS**

Fabricate, assembles, installs and repairs sheetmetal products and equipment in such areas as ventilation, air-conditioning, warm air heating, restaurant equipment, architectural sheet metal work, sheetmetal roofing, and aluminum gutters.

Fabrication, handling, assembling, erecting, altering, repairing, etc. of coated metal material panels and composite metal material panels when used on building exteriors and interiors as soffits, fascia, louvers, partitions, wall panel siding, canopies, cornice, column covers, awnings, beam covers, cladding, sun shades, lighting troughs, spires, ornamental roofing, metal ceilings, mansards, copings, ornamental and ventilation hoods, vertical and horizontal siding panels, trim, etc.

The sheet metal classification also applies to the vast variety of coated metal material panels and composite metal material panels that have evolved over the years as an alternative to conventional ferrous and non-ferrous metals like steel, iron, tin, copper, brass, bronze, aluminum, etc. Insulated metal and insulated composite panels are still installed by the Iron Worker. Fabrication, handling, assembling, erecting, altering, repairing, etc. of architectural metal roof, standing seam roof, composite metal roof, metal and composite bathroom/toilet partitions, aluminum gutters, metal and composite lockers and shelving, kitchen equipment, and walk-in coolers.

- **SPRINKLER FITTERS**

Installation, alteration, maintenance and repair of fire protection sprinkler systems.

**\*License required per Connecticut General Statutes: F-1,2,3,4.**

- **TILE MARBLE AND TERRAZZO FINISHERS**

Assists and tends the tile setter, marble mason and terrazzo worker in the performance of their duties.

- **TRUCK DRIVERS**

**Definitions:**

1) “Site of the work” (29 Code of Federal Regulations (CFR) 5.2(l)(b) is the physical place or places where the building or work called for in the contract will remain and any other site where a significant portion of the building or work is constructed, provided that such site is established specifically for the performance of the contract or project;

(a) Except as provided in paragraph (l) (3) of this section, job headquarters, tool yards, batch plants, borrow pits, etc. are part of the “site of the work”; provided they are dedicated exclusively, or nearly so, to the performance of the contract or project, and provided they are adjacent to “the site of work” as defined in paragraph (e)(1) of this section;

(b) Not included in the “site of the work” are permanent home offices, branch plant establishments, fabrication plants, tool yards etc, of a contractor or subcontractor whose location and continuance in operation are determined wholly without regard to a particular State or political subdivision contract or uncertain and indefinite periods of time involved of a few seconds or minutes duration and where the failure to count such time is due to consideration justified by industrial realities (29 CFR 785.47)

2) “Engaged to wait” is waiting time that belongs to and is controlled by the employer which is an integral part of the job and is therefore compensable as hours worked. (29 CFR 785.15)

3) “Waiting to be engaged” is waiting time that an employee can use effectively for their own purpose and is not compensable as hours worked. (29 CFR 785.16)

4) “De Minimus” is a rule that recognizes that unsubstantial or insignificant periods of time which cannot as a practical administrative matter be precisely recorded for payroll purposes, may be disregarded. This rule applies only where there are uncertain and indefinite periods of time involved of a short duration and where the failure to count such time is due to consideration justified by worksite realities. For example, with respect to truck drivers on prevailing wage sites, this is typically less than 15 minutes at a time.

**Coverage of Truck Drivers on State or Political subdivision Prevailing Wage Projects**

**Truck drivers are covered for payroll purposes under the following conditions:**

- Truck Drivers for time spent working on the site of the work.
- Truck Drivers for time spent loading and/or unloading materials and supplies on the site of the work, if such time is not de minimus

- Truck drivers transporting materials or supplies between a facility that is deemed part of the site of the work and the actual construction site.
- Truck drivers transporting portions of the building or work between a site established specifically for the performance of the contract or project where a significant portion of such building or work is constructed and the physical places where the building or work outlined in the contract will remain.

*For example: Truck drivers delivering asphalt are covered under prevailing wage while “engaged to wait” on the site and when directly involved in the paving operation, provided the total time is not “de minimus”*

**Truck Drivers are not covered in the following instances:**

- Material delivery truck drivers while off “the site of the work”
- Truck Drivers traveling between a prevailing wage job and a commercial supply facility while they are off the “site of the work”
- Truck drivers whose time spent on the “site of the work” is de minimus, such as under 15 minutes at a time, merely to drop off materials or supplies, including asphalt.

*These guidelines are similar to U.S. Labor Department policies. The application of these guidelines may be subject to review based on factual considerations on a case by case basis.*

**For example:**

- Material men and deliverymen are not covered under prevailing wage as long as they are not directly involved in the construction process. If, they unload the material, they would then be covered by prevailing wage for the classification they are performing work in: laborer, equipment operator, etc.
- Hauling material off site is not covered provided they are not dumping it at a location outlined above.
- Driving a truck on site and moving equipment or materials on site would be considered covered work, as this is part of the construction process.

*Any questions regarding the proper classification should be directed to:*

*Public Contract Compliance Unit  
Wage and Workplace Standards Division  
Connecticut Department of Labor  
200 Folly Brook Blvd, Wethersfield, CT 06109  
(860) 263-6543*

Connecticut Department of Labor  
Wage and Workplace Standards Division  
FOOTNOTES

Please Note: If the “Benefits” listed on the schedule for the following occupations includes a letter(s) (+ a or + a+b for instance), refer to the information below.

Benefits to be paid at the appropriate prevailing wage rate for the listed occupation.

If the “Benefits” section for the occupation lists only a dollar amount, disregard the information below.

**Bricklayers, Cement Masons, Cement Finishers, Concrete Finishers, Stone Masons**  
(Building Construction) and  
(Residential- Hartford, Middlesex, New Haven, New London and Tolland Counties)

- a. Paid Holiday: Employees shall receive 4 hours for Christmas Eve holiday provided the employee works the regularly scheduled day before and after the holiday. Employers may schedule work on Christmas Eve and employees shall receive pay for actual hours worked in addition to holiday pay.

**Elevator Constructors: Mechanics**

- a. Paid Holidays: New Year’s Day, Memorial Day, Independence Day, Labor Day, Veterans’ Day, Thanksgiving Day, Christmas Day, plus the Friday after Thanksgiving.
- b. Vacation: Employer contributes 8% of basic hourly rate for 5 years or more of service or 6% of basic hourly rate for 6 months to 5 years of service as vacation pay credit.

**Glaziers**

- a. Paid Holidays: Labor Day and Christmas Day.

**Power Equipment Operators**  
(Heavy and Highway Construction & Building Construction)

- a. Paid Holidays: New Year’s Day, Good Friday, Memorial day, Independence Day, Labor Day, Thanksgiving Day and Christmas Day, provided the employee works 3 days during the week in which the holiday falls, if scheduled, and if scheduled, the working day before and the working day after the holiday. Holidays falling on Saturday may be observed on Saturday, or if the employer so elects, on the preceding Friday.

Connecticut Department of Labor  
Wage and Workplace Standards Division  
FOOTNOTES

**Ironworkers**

- a. Paid Holiday: Labor Day provided employee has been on the payroll for the 5 consecutive work days prior to Labor Day.

**Laborers (Tunnel Construction)**

- a. Paid Holidays: New Year's Day, Memorial Day, Independence Day, Labor Day, Thanksgiving Day and Christmas Day. No employee shall be eligible for holiday pay when he fails, without cause, to work the regular work day preceding the holiday or the regular work day following the holiday.

**Roofers**

- a. Paid Holidays: July 4<sup>th</sup>, Labor Day, and Christmas Day provided the employee is employed 15 days prior to the holiday.

**Sprinkler Fitters**

- a. Paid Holidays: Memorial Day, July 4th, Labor Day, Thanksgiving Day and Christmas Day, provided the employee has been in the employment of a contractor 20 working days prior to any such paid holiday.

**Truck Drivers**

(Heavy and Highway Construction & Building Construction)

- a. Paid Holidays: New Year's Day, Memorial Day, Independence Day, Labor Day, Thanksgiving Day, Christmas day, and Good Friday, provided the employee has at least 31 calendar days of service and works the last scheduled day before and the first scheduled day after the holiday, unless excused.





**NON-COLLUSION AFFIDAVIT**

State of \_\_\_\_\_:

County of \_\_\_\_\_:s.s.

I state that I am the \_\_\_\_\_ of \_\_\_\_\_  
(TITLE) (NAME OF MY FIRM)

and that I am authorized to make this affidavit on behalf of my firm, and its owners, directors, and officers. I am the person responsible in my firm for the price(s) and the amount of this bid.

I state that:

- (1) The price(s) and amount of this bid have been arrived at independently and without consultation communication or agreement with any other contractor, bidder/proposer or potential bidder/proposer.
- (2) Neither the price(s) nor the amount of this bid/rfp, and neither the approximate price(s) nor approximate amount of this bid/rfp, have been disclosed to any other firm or person who is a bidder/proposer or potential bidder/proposer, and they will not be disclosed before bid/rfp opening.
- (3) No attempt has been made or will be made to induce any firm or person to refrain from bidding/proposing on this contract, or to submit a bid/proposal higher than this bid/rfp, or to submit any intentionally high or noncompetitive bid/rfp or other form of complementary bid/rfp.
- (4) I fully understand that more than one offer from an individual, firm partnership; corporation or association under the same or different name will be rejected. Reasonable grounds for believing that a bidder/proposer is interested in more than one bid/rfp for the work contemplated may cause rejection of all bids/rfps in which the bidder/proposer is interested. Any or all bidders/proposers will be rejected if there is any reason for believing that collusion exists among the bidders/proposers. Participants in such collusion may not be considered in the future offers for the same work. Each bidder/proposer by submitting a bid/proposal certifies that it is not a part to any collusive action.
- (5) The bid/rfp of my firm is made in good faith and not pursuant to any agreement or discussion with, or inducement from, any firm or person to submit a complementary or other noncompetitive bid/proposal.

(6) \_\_\_\_\_ its affiliates, subsidiaries, officers,  
(NAME OF MY FIRM)  
directors and employees are not currently under investigation by any governmental agency and have not in the last four years been convicted or found liable for any act prohibited by State or Federal law in any jurisdiction, involving conspiracy or collusion with respect to bidding/proposing on any public contract, except as follows:

I state that \_\_\_\_\_ understands and acknowledges that  
(NAME OF MY FIRM)

the above representations are material and important, and will be relied on by the Town of

**NON-COLLUSION AFFIDAVIT**

Stratford in awarding the bid/proposal for which this is submitted. I understand and my firm understands that any misstatement in this affidavit is and shall be treated as fraudulent concealment from the Town of Stratford of the true facts relating to the submission of bids/proposals for this contract.

- (7) I agree to furnish and deliver all services on the date and time agreed on by \_\_\_\_\_ and the Town of Stratford once the \_\_\_\_\_  
(NAME OF MY FIRM)

Contract is signed. Furthermore, there will not be any cancellations to the Town of Stratford. If a bidder/proposer submits a bid/proposal on any services he/she will be responsible for delivering that service at the bid/proposal cost, in accordance with the attached above specifications, which were submitted with this bid/proposal and upon which the bid/proposal was made.

- (8) In submitting this bid/proposal, the undersigned declares that this is made without any connection with any persons making another bid/proposal on the same contract; that the bid/proposal is in all respects fair and without collusion, fraud or mental reservation; and that no official of the Town, or any person in the employ of the Town, is directly or indirectly interested in said bid/proposal or in the supplies or work to which it relates, or in any portion of the profits thereof.
- (9) The undersigned further understands that the above declarations are material representations to the Town of Stratford made as a condition to the acceptance of the bid/proposal. If found to be false, the Town of Stratford retains the right to reject said bid/proposal and rescind any resultant contract and/or purchase order and notify the undersigned accordingly, thereby declaring as void said bid/proposal and contract or purchase order.

CONTINUED >>>

**NON-COLLUSION AFFIDAVIT**

VENDOR INFORMATION. (Please print the following)

\_\_\_\_\_  
VENDOR NAME

\_\_\_\_\_  
ADDRESS

\_\_\_\_\_  
TELEPHONE

\_\_\_\_\_  
FAX #

\_\_\_\_\_  
E-MAIL

\_\_\_\_\_  
WEB SITE

\_\_\_\_\_  
AUTHORIZED SIGNATURE

\_\_\_\_\_  
TITLE

(12) By signing this bid/proposal the bidder/proposer understands and agrees to the attached terms, conditions, and specifications, including Collusion among Bidders/Proposers Employment Discrimination by the Contractor Prohibited.

\_\_\_\_\_  
SIGNATURE

SWORN AND SUBSCRIBED TO BEFORE ME, A NOTARY PUBLIC, IN AND FOR THE COUNTY OF \_\_\_\_\_ AND THE STATE OF \_\_\_\_\_

\_\_\_\_\_  
THIS

\_\_\_\_\_  
DAY OF \_\_\_\_\_, 2014

\_\_\_\_\_  
NOTARY PUBLIC

MY COMMISSION EXPIRES \_\_\_\_\_

**NON-COLLUSION AFFIDAVIT**





# AIA® Document A101™ – 2007

## **Standard Form of Agreement Between Owner and Contractor where the basis of payment is a Stipulated Sum**

**AGREEMENT** made as of the    day of    in the year  
*(In words, indicate day, month and year)*

**BETWEEN** the Owner:  
*(Name, legal status, address and other information)*

and the Contractor:  
*(Name, legal status, address and other information)*

for the following Project:  
*(Name, location and detailed description)*

**The Architect:**  
*(Name, legal status, address and other information)*

The Owner and Contractor agree as follows.

**ADDITIONS AND DELETIONS:**  
The author of this document has added information needed for its completion. The author may also have revised the text of the original AIA standard form. An *Additions and Deletions Report* that notes added information as well as revisions to the standard form text is available from the author and should be reviewed. A vertical line in the left margin of this document indicates where the author has added necessary information and where the author has added to or deleted from the original AIA text.

This document has important legal consequences. Consultation with an attorney is encouraged with respect to its completion or modification.

AIA Document A201™–2007, General Conditions of the Contract for Construction, is adopted in this document by reference. Do not use with other general conditions unless this document is modified.

## TABLE OF ARTICLES

- 1 THE CONTRACT DOCUMENTS
- 2 THE WORK OF THIS CONTRACT
- 3 DATE OF COMMENCEMENT AND SUBSTANTIAL COMPLETION
- 4 CONTRACT SUM
- 5 PAYMENTS
- 6 DISPUTE RESOLUTION
- 7 TERMINATION OR SUSPENSION
- 8 MISCELLANEOUS PROVISIONS
- 9 ENUMERATION OF CONTRACT DOCUMENTS
- 10 INSURANCE AND BONDS

### ARTICLE 1 THE CONTRACT DOCUMENTS

The Contract Documents consist of this Agreement, Conditions of the Contract (General, Supplementary and other Conditions), Drawings, Specifications, Addenda issued prior to execution of this Agreement, other documents listed in this Agreement and Modifications issued after execution of this Agreement, all of which form the Contract, and are as fully a part of the Contract as if attached to this Agreement or repeated herein. The Contract represents the entire and integrated agreement between the parties hereto and supersedes prior negotiations, representations or agreements, either written or oral. An enumeration of the Contract Documents, other than a Modification, appears in Article 9.

### ARTICLE 2 THE WORK OF THIS CONTRACT

The Contractor shall fully execute the Work described in the Contract Documents, except as specifically indicated in the Contract Documents to be the responsibility of others.

### ARTICLE 3 DATE OF COMMENCEMENT AND SUBSTANTIAL COMPLETION

§ 3.1 The date of commencement of the Work shall be the date of this Agreement unless a different date is stated below or provision is made for the date to be fixed in a notice to proceed issued by the Owner.

*(Insert the date of commencement if it differs from the date of this Agreement or, if applicable, state that the date will be fixed in a notice to proceed.)*

If, prior to the commencement of the Work, the Owner requires time to file mortgages and other security interests, the Owner's time requirement shall be as follows:

§ 3.2 The Contract Time shall be measured from the date of commencement.

§ 3.3 The Contractor shall achieve Substantial Completion of the entire Work not later than ( ) days from the date of commencement, or as follows:

*(Insert number of calendar days. Alternatively, a calendar date may be used when coordinated with the date of commencement. If appropriate, insert requirements for earlier Substantial Completion of certain portions of the Work.)*

**Portion of Work**

**Substantial Completion Date**

, subject to adjustments of this Contract Time as provided in the Contract Documents.  
*(Insert provisions, if any, for liquidated damages relating to failure to achieve Substantial Completion on time or for bonus payments for early completion of the Work.)*

**ARTICLE 4 CONTRACT SUM**

§ 4.1 The Owner shall pay the Contractor the Contract Sum in current funds for the Contractor’s performance of the Contract. The Contract Sum shall be (\$ ), subject to additions and deductions as provided in the Contract Documents.

§ 4.2 The Contract Sum is based upon the following alternates, if any, which are described in the Contract Documents and are hereby accepted by the Owner:  
*(State the numbers or other identification of accepted alternates. If the bidding or proposal documents permit the Owner to accept other alternates subsequent to the execution of this Agreement, attach a schedule of such other alternates showing the amount for each and the date when that amount expires.)*

§ 4.3 Unit prices, if any:  
*(Identify and state the unit price; state quantity limitations, if any, to which the unit price will be applicable.)*

Item	Units and Limitations	Price Per Unit (\$ 0.00)
------	-----------------------	--------------------------

§ 4.4 Allowances included in the Contract Sum, if any:  
*(Identify allowance and state exclusions, if any, from the allowance price.)*

Item	Price
------	-------

**ARTICLE 5 PAYMENTS**

**§ 5.1 PROGRESS PAYMENTS**

§ 5.1.1 Based upon Applications for Payment submitted to the Architect by the Contractor and Certificates for Payment issued by the Architect, the Owner shall make progress payments on account of the Contract Sum to the Contractor as provided below and elsewhere in the Contract Documents.

§ 5.1.2 The period covered by each Application for Payment shall be one calendar month ending on the last day of the month, or as follows:

§ 5.1.3 Provided that an Application for Payment is received by the Architect not later than the day of a month, the Owner shall make payment of the certified amount to the Contractor not later than the day of the month. If an Application for Payment is received by the Architect after the application date fixed above, payment shall be made by the Owner not later than ( ) days after the Architect receives the Application for Payment.  
*(Federal, state or local laws may require payment within a certain period of time.)*

§ 5.1.4 Each Application for Payment shall be based on the most recent schedule of values submitted by the Contractor in accordance with the Contract Documents. The schedule of values shall allocate the entire Contract Sum among the various portions of the Work. The schedule of values shall be prepared in such form and supported by such data to substantiate its accuracy as the Architect may require. This schedule, unless objected to by the Architect, shall be used as a basis for reviewing the Contractor’s Applications for Payment.

§ 5.1.5 Applications for Payment shall show the percentage of completion of each portion of the Work as of the end of the period covered by the Application for Payment.

§ 5.1.6 Subject to other provisions of the Contract Documents, the amount of each progress payment shall be computed as follows:

- .1 Take that portion of the Contract Sum properly allocable to completed Work as determined by multiplying the percentage completion of each portion of the Work by the share of the Contract Sum allocated to that portion of the Work in the schedule of values, less retainage of ( ). Pending final determination of cost to the Owner of changes in the Work, amounts not in dispute shall be included as provided in Section 7.3.9 of AIA Document A201™–2007, General Conditions of the Contract for Construction;
- .2 Add that portion of the Contract Sum properly allocable to materials and equipment delivered and suitably stored at the site for subsequent incorporation in the completed construction (or, if approved in advance by the Owner, suitably stored off the site at a location agreed upon in writing), less retainage of ( );
- .3 Subtract the aggregate of previous payments made by the Owner; and
- .4 Subtract amounts, if any, for which the Architect has withheld or nullified a Certificate for Payment as provided in Section 9.5 of AIA Document A201–2007.

§ 5.1.7 The progress payment amount determined in accordance with Section 5.1.6 shall be further modified under the following circumstances:

- .1 Add, upon Substantial Completion of the Work, a sum sufficient to increase the total payments to the full amount of the Contract Sum, less such amounts as the Architect shall determine for incomplete Work, retainage applicable to such work and unsettled claims; and  
(Section 9.8.5 of AIA Document A201–2007 requires release of applicable retainage upon Substantial Completion of Work with consent of surety, if any.)
- .2 Add, if final completion of the Work is thereafter materially delayed through no fault of the Contractor, any additional amounts payable in accordance with Section 9.10.3 of AIA Document A201–2007.

§ 5.1.8 Reduction or limitation of retainage, if any, shall be as follows:

*(If it is intended, prior to Substantial Completion of the entire Work, to reduce or limit the retainage resulting from the percentages inserted in Sections 5.1.6.1 and 5.1.6.2 above, and this is not explained elsewhere in the Contract Documents, insert here provisions for such reduction or limitation.)*

§ 5.1.9 Except with the Owner's prior approval, the Contractor shall not make advance payments to suppliers for materials or equipment which have not been delivered and stored at the site.

## § 5.2 FINAL PAYMENT

§ 5.2.1 Final payment, constituting the entire unpaid balance of the Contract Sum, shall be made by the Owner to the Contractor when

- .1 the Contractor has fully performed the Contract except for the Contractor's responsibility to correct Work as provided in Section 12.2.2 of AIA Document A201–2007, and to satisfy other requirements, if any, which extend beyond final payment; and
- .2 a final Certificate for Payment has been issued by the Architect.

§ 5.2.2 The Owner's final payment to the Contractor shall be made no later than 30 days after the issuance of the Architect's final Certificate for Payment, or as follows:

## ARTICLE 6 DISPUTE RESOLUTION

### § 6.1 INITIAL DECISION MAKER

The Architect will serve as Initial Decision Maker pursuant to Section 15.2 of AIA Document A201–2007, unless the parties appoint below another individual, not a party to this Agreement, to serve as Initial Decision Maker.



*(If the parties mutually agree, insert the name, address and other contact information of the Initial Decision Maker, if other than the Architect.)*

**§ 6.2 BINDING DISPUTE RESOLUTION**

For any Claim subject to, but not resolved by, mediation pursuant to Section 15.3 of AIA Document A201–2007, the method of binding dispute resolution shall be as follows:

*(Check the appropriate box. If the Owner and Contractor do not select a method of binding dispute resolution below, or do not subsequently agree in writing to a binding dispute resolution method other than litigation, Claims will be resolved by litigation in a court of competent jurisdiction.)*

- Arbitration pursuant to Section 15.4 of AIA Document A201–2007
- Litigation in a court of competent jurisdiction
- Other *(Specify)*

**ARTICLE 7 TERMINATION OR SUSPENSION**

**§ 7.1** The Contract may be terminated by the Owner or the Contractor as provided in Article 14 of AIA Document A201–2007.

**§ 7.2** The Work may be suspended by the Owner as provided in Article 14 of AIA Document A201–2007.

**ARTICLE 8 MISCELLANEOUS PROVISIONS**

**§ 8.1** Where reference is made in this Agreement to a provision of AIA Document A201–2007 or another Contract Document, the reference refers to that provision as amended or supplemented by other provisions of the Contract Documents.

**§ 8.2** Payments due and unpaid under the Contract shall bear interest from the date payment is due at the rate stated below, or in the absence thereof, at the legal rate prevailing from time to time at the place where the Project is located. *(Insert rate of interest agreed upon, if any.)*

**§ 8.3** The Owner's representative:  
*(Name, address and other information)*

**§ 8.4** The Contractor's representative:  
*(Name, address and other information)*

§ 8.5 Neither the Owner's nor the Contractor's representative shall be changed without ten days written notice to the other party.

§ 8.6 Other provisions:

**ARTICLE 9 ENUMERATION OF CONTRACT DOCUMENTS**

§ 9.1 The Contract Documents, except for Modifications issued after execution of this Agreement, are enumerated in the sections below.

§ 9.1.1 The Agreement is this executed AIA Document A101–2007, Standard Form of Agreement Between Owner and Contractor.

§ 9.1.2 The General Conditions are AIA Document A201–2007, General Conditions of the Contract for Construction.

§ 9.1.3 The Supplementary and other Conditions of the Contract:

Document	Title	Date	Pages
----------	-------	------	-------

§ 9.1.4 The Specifications:

*(Either list the Specifications here or refer to an exhibit attached to this Agreement.)*

Section	Title	Date	Pages
---------	-------	------	-------

§ 9.1.5 The Drawings:

*(Either list the Drawings here or refer to an exhibit attached to this Agreement.)*

Number	Title	Date
--------	-------	------

§ 9.1.6 The Addenda, if any:

Number	Date	Pages
--------	------	-------

Portions of Addenda relating to bidding requirements are not part of the Contract Documents unless the bidding requirements are also enumerated in this Article 9.

§ 9.1.7 Additional documents, if any, forming part of the Contract Documents:

.1 AIA Document E201™–2007, Digital Data Protocol Exhibit, if completed by the parties, or the following:

.2 Other documents, if any, listed below:

*(List here any additional documents that are intended to form part of the Contract Documents. AIA Document A201–2007 provides that bidding requirements such as advertisement or invitation to bid, Instructions to Bidders, sample forms and the Contractor's bid are not part of the Contract Documents)*

*unless enumerated in this Agreement. They should be listed here only if intended to be part of the Contract Documents.)*

**ARTICLE 10 INSURANCE AND BONDS**

The Contractor shall purchase and maintain insurance and provide bonds as set forth in Article 11 of AIA Document A201-2007.

*(State bonding requirements, if any, and limits of liability for insurance required in Article 11 of AIA Document A201-2007.)*

Type of insurance or bond	Limit of liability or bond amount (\$ 0.00)
---------------------------	---

This Agreement entered into as of the day and year first written above.

\_\_\_\_\_  
OWNER (Signature)

\_\_\_\_\_  
CONTRACTOR (Signature)

\_\_\_\_\_  
(Printed name and title)

\_\_\_\_\_  
(Printed name and title)

Init.





# AIA<sup>®</sup> Document A201<sup>™</sup> – 2007

## General Conditions of the Contract for Construction

for the following PROJECT:  
*(Name and location or address)*

**THE OWNER:**  
*(Name, legal status and address)*  
Town of Stratford  
2725 Main Street, Stratford, CT 06615

**THE ARCHITECT:**  
*(Name, legal status and address)*

### TABLE OF ARTICLES

- 1 GENERAL PROVISIONS
- 2 OWNER
- 3 CONTRACTOR
- 4 ARCHITECT
- 5 SUBCONTRACTORS
- 6 CONSTRUCTION BY OWNER OR BY SEPARATE CONTRACTORS
- 7 CHANGES IN THE WORK
- 8 TIME
- 9 PAYMENTS AND COMPLETION
- 10 PROTECTION OF PERSONS AND PROPERTY
- 11 INSURANCE AND BONDS
- 12 UNCOVERING AND CORRECTION OF WORK
- 13 MISCELLANEOUS PROVISIONS
- 14 TERMINATION OR SUSPENSION OF THE CONTRACT
- 15 CLAIMS AND DISPUTES

**ADDITIONS AND DELETIONS:**  
The author of this document has added information needed for its completion. The author may also have revised the text of the original AIA standard form. An *Additions and Deletions Report* that notes added information as well as revisions to the standard form text is available from the author and should be reviewed. A vertical line in the left margin of this document indicates where the author has added necessary information and where the author has added to or deleted from the original AIA text.

This document has important legal consequences. Consultation with an attorney is encouraged with respect to its completion or modification.

init.

## INDEX

(Numbers and Topics in Bold are Section Headings)

### Acceptance of Nonconforming Work

9.6.6, 9.9.3, **12.3**

#### Acceptance of Work

9.6.6, 9.8.2, 9.9.3, 9.10.1, 9.10.3, **12.3**

#### Access to Work

**3.16**, 6.2.1, 12.1

#### Accident Prevention

10

#### Acts and Omissions

3.2, 3.3.2, 3.12.8, 3.18, 4.2.3, 8.3.1, 9.5.1, 10.2.5, 10.2.8, 13.4.2, 13.7.1, 14.1, 15.2

#### Addenda

1.1.1, 3.11.1

#### Additional Costs, Claims for

3.7.4, 3.7.5, 6.1.1, 7.3.7.5, 10.3, 15.1.4

#### Additional Inspections and Testing

9.4.2, 9.8.3, 12.2.1, **13.5**

#### Additional Insured

11.1.4

#### Additional Time, Claims for

3.2.4, 3.7.4, 3.7.5, 3.10.2, 8.3.2, **15.1.5**

#### Administration of the Contract

3.1.3, **4.2**, 9.4, 9.5

#### Advertisement or Invitation to Bid

1.1.1

#### Aesthetic Effect

4.2.13

#### Allowances

**3.8**, 7.3.8

#### All-risk Insurance

11.3.1, 11.3.1.1

#### Applications for Payment

4.2.5, 7.3.9, 9.2, 9.3, 9.4, 9.5.1, 9.6.3, 9.7.1, 9.10, 11.1.3

#### Approvals

2.1.1, 2.2.2, 2.4, 3.1.3, 3.10.2, 3.12.8, 3.12.9, 3.12.10, 4.2.7, 9.3.2, 13.5.1

#### Arbitration

8.3.1, 11.3.10, 13.1.1, 15.3.2, **15.4**

## ARCHITECT

4

#### Architect, Definition of

**4.1.1**

#### Architect, Extent of Authority

2.4.1, 3.12.7, 4.1, 4.2, 5.2, 6.3.1, 7.1.2, 7.3.7, 7.4, 9.2.1, 9.3.1, 9.4, 9.5, 9.6.3, 9.8, 9.10.1, 9.10.3, 12.1, 12.2.1, 13.5.1, 13.5.2, 14.2.2, 14.2.4, 15.1.3, 15.2.1

#### Architect, Limitations of Authority and Responsibility

2.1.1, 3.12.4, 3.12.8, 3.12.10, 4.1.2, 4.2.1, 4.2.2, 4.2.3, 4.2.6, 4.2.7, 4.2.10, 4.2.12, 4.2.13, 5.2.1, 7.4.1, 9.4.2, 9.5.3, 9.6.4, 15.1.3, 15.2

#### Architect's Additional Services and Expenses

2.4.1, 11.3.1.1, 12.2.1, 13.5.2, 13.5.3, 14.2.4

#### Architect's Administration of the Contract

3.1.3, 4.2, 3.7.4, 15.2, 9.4.1, 9.5

#### Architect's Approvals

2.4.1, 3.1.3, 3.5.1, 3.10.2, 4.2.7

#### Architect's Authority to Reject Work

3.5.1, 4.2.6, 12.1.2, 12.2.1

#### Architect's Copyright

1.1.7, 1.5

#### Architect's Decisions

3.7.4, 4.2.6, 4.2.7, 4.2.11, 4.2.12, 4.2.13, 4.2.14, 6.3.1, 7.3.7, 7.3.9, 8.1.3, 8.3.1, 9.2.1, 9.4.1, 9.5, 9.8.4, 9.9.1, 13.5.2, 15.2, 15.3

#### Architect's Inspections

3.7.4, 4.2.2, 4.2.9, 9.4.2, 9.8.3, 9.9.2, 9.10.1, 13.5

#### Architect's Instructions

3.2.4, 3.3.1, 4.2.6, 4.2.7, 13.5.2

#### Architect's Interpretations

4.2.11, 4.2.12

#### Architect's Project Representative

4.2.10

#### Architect's Relationship with Contractor

1.1.2, 1.5, 3.1.3, 3.2.2, 3.2.3, 3.2.4, 3.3.1, 3.4.2, 3.5.1, 3.7.4, 3.7.5, 3.9.2, 3.9.3, 3.10, 3.11, 3.12, 3.16, 3.18, 4.1.2, 4.1.3, 4.2, 5.2, 6.2.2, 7, 8.3.1, 9.2, 9.3, 9.4, 9.5, 9.7, 9.8, 9.9, 10.2.6, 10.3, 11.3.7, 12, 13.4.2, 13.5, 15.2

#### Architect's Relationship with Subcontractors

1.1.2, 4.2.3, 4.2.4, 4.2.6, 9.6.3, 9.6.4, 11.3.7

#### Architect's Representations

9.4.2, 9.5.1, 9.10.1

#### Architect's Site Visits

3.7.4, 4.2.2, 4.2.9, 9.4.2, 9.5.1, 9.9.2, 9.10.1, 13.5

#### Asbestos

10.3.1

#### Attorneys' Fees

3.18.1, 9.10.2, 10.3.3

#### Award of Separate Contracts

6.1.1, 6.1.2

#### Award of Subcontracts and Other Contracts for Portions of the Work

**5.2**

#### Basic Definitions

**1.1**

#### Bidding Requirements

1.1.1, 5.2.1, 11.4.1

#### Binding Dispute Resolution

9.7.1, 11.3.9, 11.3.10, 13.1.1, 15.2.5, 15.2.6.1, 15.3.1, 15.3.2, 15.4.1

#### Boiler and Machinery Insurance

**11.3.2**

#### Bonds, Lien

7.3.7.4, 9.10.2, 9.10.3

#### Bonds, Performance, and Payment

7.3.7.4, 9.6.7, 9.10.3, 11.3.9, 11.4

Building Permit  
 3.7.1  
**Capitalization**  
 1.3  
 Certificate of Substantial Completion  
 9.8.3, 9.8.4, 9.8.5  
 Certificates for Payment  
 4.2.1, 4.2.5, 4.2.9, 9.3.3, 9.4, 9.5, 9.6.1, 9.6.6, 9.7.1,  
 9.10.1, 9.10.3, 14.1.1.3, 14.2.4, 15.1.3  
 Certificates of Inspection, Testing or Approval  
 13.5.4  
 Certificates of Insurance  
 9.10.2, 11.1.3  
**Change Orders**  
 1.1.1, 2.4.1, 3.4.2, 3.7.4, 3.8.2.3, 3.11.1, 3.12.8, 4.2.8,  
 5.2.3, 7.1.2, 7.1.3, 7.2, 7.3.2, 7.3.6, 7.3.9, 7.3.10, 8.3.1,  
 9.3.1.1, 9.10.3, 10.3.2, 11.3.1.2, 11.3.4, 11.3.9, 12.1.2,  
 15.1.3  
**Change Orders, Definition of**  
 7.2.1  
**CHANGES IN THE WORK**  
 2.2.1, 3.11, 4.2.8, 7, 7.2.1, 7.3.1, 7.4, 7.4.1, 8.3.1,  
 9.3.1.1, 11.3.9  
**Claims, Definition of**  
 15.1.1  
**CLAIMS AND DISPUTES**  
 3.2.4, 6.1.1, 6.3.1, 7.3.9, 9.3.3, 9.10.4, 10.3.3, 15, 15.4  
**Claims and Timely Assertion of Claims**  
 15.4.1  
**Claims for Additional Cost**  
 3.2.4, 3.7.4, 6.1.1, 7.3.9, 10.3.2, 15.1.4  
**Claims for Additional Time**  
 3.2.4, 3.7.4.6.1.1, 8.3.2, 10.3.2, 15.1.5  
**Concealed or Unknown Conditions, Claims for**  
 3.7.4  
**Claims for Damages**  
 3.2.4, 3.18, 6.1.1, 8.3.3, 9.5.1, 9.6.7, 10.3.3, 11.1.1,  
 11.3.5, 11.3.7, 14.1.3, 14.2.4, 15.1.6  
**Claims Subject to Arbitration**  
 15.3.1, 15.4.1  
**Cleaning Up**  
 3.15, 6.3  
**Commencement of the Work, Conditions Relating to**  
 2.2.1, 3.2.2, 3.4.1, 3.7.1, 3.10.1, 3.12.6, 5.2.1, 5.2.3,  
 6.2.2, 8.1.2, 8.2.2, 8.3.1, 11.1, 11.3.1, 11.3.6, 11.4.1,  
 15.1.4  
**Commencement of the Work, Definition of**  
 8.1.2  
**Communications Facilitating Contract Administration**  
 3.9.1, 4.2.4  
**Completion, Conditions Relating to**  
 3.4.1, 3.11, 3.15, 4.2.2, 4.2.9, 8.2, 9.4.2, 9.8, 9.9.1,  
 9.10, 12.2, 13.7, 14.1.2  
**COMPLETION, PAYMENTS AND**  
 9  
**Completion, Substantial**  
 4.2.9, 8.1.1, 8.1.3, 8.2.3, 9.4.2, 9.8, 9.9.1, 9.10.3, 12.2,  
 13.7  
**Compliance with Laws**  
 1.6.1, 3.2.3, 3.6, 3.7, 3.12.10, 3.13, 4.1.1, 9.6.4, 10.2.2,  
 11.1, 11.3, 13.1, 13.4, 13.5.1, 13.5.2, 13.6, 14.1.1,  
 14.2.1.3, 15.2.8, 15.4.2, 15.4.3  
**Concealed or Unknown Conditions**  
 3.7.4, 4.2.8, 8.3.1, 10.3  
**Conditions of the Contract**  
 1.1.1, 6.1.1, 6.1.4  
**Consent, Written**  
 3.4.2, 3.7.4, 3.12.8, 3.14.2, 4.1.2, 9.3.2, 9.8.5, 9.9.1,  
 9.10.2, 9.10.3, 11.3.1, 13.2, 13.4.2, 15.4.4.2  
**Consolidation or Joinder**  
 15.4.4  
**CONSTRUCTION BY OWNER OR BY SEPARATE CONTRACTORS**  
 1.1.4, 6  
**Construction Change Directive, Definition of**  
 7.3.1  
**Construction Change Directives**  
 1.1.1, 3.4.2, 3.12.8, 4.2.8, 7.1.1, 7.1.2, 7.1.3, 7.3,  
 9.3.1.1  
**Construction Schedules, Contractor's**  
 3.10, 3.12.1, 3.12.2, 6.1.3, 15.1.5.2  
**Contingent Assignment of Subcontracts**  
 5.4, 14.2.2.2  
**Continuing Contract Performance**  
 15.1.3  
**Contract, Definition of**  
 1.1.2  
**CONTRACT, TERMINATION OR SUSPENSION OF THE**  
 5.4.1.1, 11.3.9, 14  
**Contract Administration**  
 3.1.3, 4, 9.4, 9.5  
**Contract Award and Execution, Conditions Relating to**  
 3.7.1, 3.10, 5.2, 6.1, 11.1.3, 11.3.6, 11.4.1  
**Contract Documents, The**  
 1.1.1  
**Contract Documents, Copies Furnished and Use of**  
 1.5.2, 2.2.5, 5.3  
**Contract Documents, Definition of**  
 1.1.1  
**Contract Sum**  
 3.7.4, 3.8, 5.2.3, 7.2, 7.3, 7.4, 9.1, 9.4.2, 9.5.1.4, 9.6.7,  
 9.7, 10.3.2, 11.3.1, 14.2.4, 14.3.2, 15.1.4, 15.2.5  
**Contract Sum, Definition of**  
 9.1  
**Contract Time**  
 3.7.4, 3.7.5, 3.10.2, 5.2.3, 7.2.1.3, 7.3.1, 7.3.5, 7.4,  
 8.1.1, 8.2.1, 8.3.1, 9.5.1, 9.7.1, 10.3.2, 12.1.1, 14.3.2,  
 15.1.5.1, 15.2.5  
**Contract Time, Definition of**  
 8.1.1

## CONTRACTOR

3

Contractor, Definition of

3.1, 6.1.2

Contractor's Construction Schedules

3.10, 3.12.1, 3.12.2, 6.1.3, 15.1.5.2

Contractor's Employees

3.3.2, 3.4.3, 3.8.1, 3.9, 3.18.2, 4.2.3, 4.2.6, 10.2, 10.3, 11.1.1, 11.3.7, 14.1, 14.2.1.1,

Contractor's Liability Insurance

11.1

Contractor's Relationship with Separate Contractors and Owner's Forces

3.12.5, 3.14.2, 4.2.4, 6, 11.3.7, 12.1.2, 12.2.4

Contractor's Relationship with Subcontractors

1.2.2, 3.3.2, 3.18.1, 3.18.2, 5, 9.6.2, 9.6.7, 9.10.2, 11.3.1.2, 11.3.7, 11.3.8

Contractor's Relationship with the Architect

1.1.2, 1.5, 3.1.3, 3.2.2, 3.2.3, 3.2.4, 3.3.1, 3.4.2, 3.5.1, 3.7.4, 3.10, 3.11, 3.12, 3.16, 3.18, 4.1.3, 4.2, 5.2, 6.2.2, 7, 8.3.1, 9.2, 9.3, 9.4, 9.5, 9.7, 9.8, 9.9, 10.2.6, 10.3, 11.3.7, 12, 13.5, 15.1.2, 15.2.1

Contractor's Representations

3.2.1, 3.2.2, 3.5.1, 3.12.6, 6.2.2, 8.2.1, 9.3.3, 9.8.2

Contractor's Responsibility for Those Performing the Work

3.3.2, 3.18, 5.3.1, 6.1.3, 6.2, 9.5.1, 10.2.8

Contractor's Review of Contract Documents

3.2

Contractor's Right to Stop the Work

9.7

Contractor's Right to Terminate the Contract

14.1, 15.1.6

Contractor's Submittals

3.10, 3.11, 3.12.4, 4.2.7, 5.2.1, 5.2.3, 9.2, 9.3, 9.8.2, 9.8.3, 9.9.1, 9.10.2, 9.10.3, 11.1.3, 11.4.2

Contractor's Superintendent

3.9, 10.2.6

Contractor's Supervision and Construction

Procedures

1.2.2, 3.3, 3.4, 3.12.10, 4.2.2, 4.2.7, 6.1.3, 6.2.4, 7.1.3, 7.3.5, 7.3.7, 8.2, 10, 12, 14, 15.1.3

Contractual Liability Insurance

11.1.1.8, 11.2

Coordination and Correlation

1.2, 3.2.1, 3.3.1, 3.10, 3.12.6, 6.1.3, 6.2.1

Copies Furnished of Drawings and Specifications

1.5, 2.2.5, 3.11

Copyrights

1.5, 3.17

Correction of Work

2.3, 2.4, 3.7.3, 9.4.2, 9.8.2, 9.8.3, 9.9.1, 12.1.2, 12.2

Correlation and Intent of the Contract Documents

1.2

Cost, Definition of

7.3.7

Costs

2.4.1, 3.2.4, 3.7.3, 3.8.2, 3.15.2, 5.4.2, 6.1.1, 6.2.3, 7.3.3.3, 7.3.7, 7.3.8, 7.3.9, 9.10.2, 10.3.2, 10.3.6, 11.3, 12.1.2, 12.2.1, 12.2.4, 13.5, 14

Cutting and Patching

3.14, 6.2.5

Damage to Construction of Owner or Separate

Contractors

3.14.2, 6.2.4, 10.2.1.2, 10.2.5, 10.4, 11.1.1, 11.3, 12.2.4

Damage to the Work

3.14.2, 9.9.1, 10.2.1.2, 10.2.5, 10.4.1, 11.3.1, 12.2.4

Damages, Claims for

3.2.4, 3.18, 6.1.1, 8.3.3, 9.5.1, 9.6.7, 10.3.3, 11.1.1, 11.3.5, 11.3.7, 14.1.3, 14.2.4, 15.1.6

Damages for Delay

6.1.1, 8.3.3, 9.5.1.6, 9.7, 10.3.2

Date of Commencement of the Work, Definition of

8.1.2

Date of Substantial Completion, Definition of

8.1.3

Day, Definition of

8.1.4

Decisions of the Architect

3.7.4, 4.2.6, 4.2.7, 4.2.11, 4.2.12, 4.2.13, 15.2, 6.3, 7.3.7, 7.3.9, 8.1.3, 8.3.1, 9.2.1, 9.4, 9.5.1, 9.8.4, 9.9.1, 13.5.2, 14.2.2, 14.2.4, 15.1, 15.2

Decisions to Withhold Certification

9.4.1, 9.5, 9.7, 14.1.1.3

Defective or Nonconforming Work, Acceptance, Rejection and Correction of

2.3.1, 2.4.1, 3.5.1, 4.2.6, 6.2.5, 9.5.1, 9.5.2, 9.6.6, 9.8.2, 9.9.3, 9.10.4, 12.2.1

Defective Work, Definition of

3.5.1

Definitions

1.1, 2.1.1, 3.1.1, 3.5.1, 3.12.1, 3.12.2, 3.12.3, 4.1.1, 15.1.1, 5.1, 6.1.2, 7.2.1, 7.3.1, 8.1, 9.1, 9.8.1

Delays and Extensions of Time

3.2., 3.7.4, 5.2.3, 7.2.1, 7.3.1, 7.4.1, 8.3, 9.5.1, 9.7.1, 10.3.2, 10.4.1, 14.3.2, 15.1.5, 15.2.5

Disputes

6.3.1, 7.3.9, 15.1, 15.2

Documents and Samples at the Site

3.11

Drawings, Definition of

1.1.5

Drawings and Specifications, Use and Ownership of

3.11

Effective Date of Insurance

8.2.2, 11.1.2

Emergencies

10.4, 14.1.1.2, 15.1.4

Employees, Contractor's

3.3.2, 3.4.3, 3.8.1, 3.9, 3.18.2, 4.2.3, 4.2.6, 10.2, 10.3.3, 11.1.1, 11.3.7, 14.1, 14.2.1.1



Equipment, Labor, Materials or  
 1.1.3, 1.1.6, 3.4, 3.5.1, 3.8.2, 3.8.3, 3.12, 3.13.1,  
 3.15.1, 4.2.6, 4.2.7, 5.2.1, 6.2.1, 7.3.7, 9.3.2, 9.3.3,  
 9.5.1.3, 9.10.2, 10.2.1, 10.2.4, 14.2.1.1, 14.2.1.2  
**Execution and Progress of the Work**  
 1.1.3, 1.2.1, 1.2.2, 2.2.3, 2.2.5, 3.1, 3.3.1, 3.4.1, 3.5.1,  
 3.7.1, 3.10.1, 3.12, 3.14, 4.2, 6.2.2, 7.1.3, 7.3.5, 8.2,  
 9.5.1, 9.9.1, 10.2, 10.3, 12.2, 14.2, 14.3.1, 15.1.3  
**Extensions of Time**  
 3.2.4, 3.7.4, 5.2.3, 7.2.1, 7.3, 7.4.1, 9.5.1, 9.7.1, 10.3.2,  
 10.4.1, 14.3, 15.1.5, 15.2.5  
**Failure of Payment**  
 9.5.1.3, 9.7, 9.10.2, 13.6, 14.1.1.3, 14.2.1.2  
**Faulty Work**  
 (See Defective or Nonconforming Work)  
**Final Completion and Final Payment**  
 4.2.1, 4.2.9, 9.8.2, 9.10, 11.1.2, 11.1.3, 11.3.1, 11.3.5,  
 12.3.1, 14.2.4, 14.4.3  
**Financial Arrangements, Owner's**  
 2.2.1, 13.2.2, 14.1.1.4  
**Fire and Extended Coverage Insurance**  
 11.3.1.1  
**GENERAL PROVISIONS**  
**1**  
**Governing Law**  
**13.1**  
**Guarantees (See Warranty)**  
**Hazardous Materials**  
 10.2.4, 10.3  
**Identification of Subcontractors and Suppliers**  
 5.2.1  
**Indemnification**  
 3.17.1, 3.18, 9.10.2, 10.3.3, 10.3.5, 10.3.6, 11.3.1.2,  
 11.3.7  
**Information and Services Required of the Owner**  
 2.1.2, 2.2, 3.2.2, 3.12.4, 3.12.10, 6.1.3, 6.1.4, 6.2.5,  
 9.6.1, 9.6.4, 9.9.2, 9.10.3, 10.3.3, 11.2, 11.4, 13.5.1,  
 13.5.2, 14.1.1.4, 14.1.4, 15.1.3  
**Initial Decision**  
**15.2**  
**Initial Decision Maker, Definition of**  
 1.1.8  
**Initial Decision Maker, Decisions**  
 14.2.2, 14.2.4, 15.2.1, 15.2.2, 15.2.3, 15.2.4, 15.2.5  
**Initial Decision Maker, Extent of Authority**  
 14.2.2, 14.2.4, 15.1.3, 15.2.1, 15.2.2, 15.2.3, 15.2.4,  
 15.2.5  
**Injury or Damage to Person or Property**  
**10.2.8, 10.4.1**  
**Inspections**  
 3.1.3, 3.3.3, 3.7.1, 4.2.2, 4.2.6, 4.2.9, 9.4.2, 9.8.3,  
 9.9.2, 9.10.1, 12.2.1, 13.5  
**Instructions to Bidders**  
 1.1.1  
**Instructions to the Contractor**  
 3.2.4, 3.3.1, 3.8.1, 5.2.1, 7, 8.2.2, 12, 13.5.2

**Instruments of Service, Definition of**  
**1.1.7**  
**Insurance**  
 3.18.1, 6.1.1, 7.3.7, 9.3.2, 9.8.4, 9.9.1, 9.10.2, 11  
**Insurance, Boiler and Machinery**  
**11.3.2**  
**Insurance, Contractor's Liability**  
**11.1**  
**Insurance, Effective Date of**  
 8.2.2, 11.1.2  
**Insurance, Loss of Use**  
**11.3.3**  
**Insurance, Owner's Liability**  
**11.2**  
**Insurance, Property**  
 10.2.5, 11.3  
**Insurance, Stored Materials**  
 9.3.2, 11.4.1.4  
**INSURANCE AND BONDS**  
**11**  
**Insurance Companies, Consent to Partial Occupancy**  
 9.9.1, 11.4.1.5  
**Insurance Companies, Settlement with**  
 11.4.10  
**Intent of the Contract Documents**  
 1.2.1, 4.2.7, 4.2.12, 4.2.13, 7.4  
**Interest**  
**13.6**  
**Interpretation**  
 1.2.3, 1.4, 4.1.1, 5.1, 6.1.2, 15.1.1  
**Interpretations, Written**  
 4.2.11, 4.2.12, 15.1.4  
**Judgment on Final Award**  
 15.4.2  
**Labor and Materials, Equipment**  
 1.1.3, 1.1.6, 3.4, 3.5.1, 3.8.2, 3.8.3, 3.12, 3.13, 3.15.1,  
 4.2.6, 4.2.7, 5.2.1, 6.2.1, 7.3.7, 9.3.2, 9.3.3, 9.5.1.3,  
 9.10.2, 10.2.1, 10.2.4, 14.2.1.1, 14.2.1.2  
**Labor Disputes**  
 8.3.1  
**Laws and Regulations**  
 1.5, 3.2.3, 3.6, 3.7, 3.12.10, 3.13.1, 4.1.1, 9.6.4, 9.9.1,  
 10.2.2, 11.1.1, 11.3, 13.1.1, 13.4, 13.5.1, 13.5.2,  
 13.6.1, 14, 15.2.8, 15.4  
**Liens**  
 2.1.2, 9.3.3, 9.10.2, 9.10.4, 15.2.8  
**Limitations, Statutes of**  
 12.2.5, 13.7, 15.4.1.1  
**Limitations of Liability**  
 2.3.1, 3.2.2, 3.5.1, 3.12.10, 3.17.1, 3.18.1, 4.2.6, 4.2.7,  
 4.2.12, 6.2.2, 9.4.2, 9.6.4, 9.6.7, 10.2.5, 10.3.3, 11.1.2,  
 11.2, 11.3.7, 12.2.5, 13.4.2  
**Limitations of Time**  
 2.1.2, 2.2, 2.4, 3.2.2, 3.10, 3.11, 3.12.5, 3.15.1, 4.2.7,  
 5.2, 5.3.1, 5.4.1, 6.2.4, 7.3, 7.4, 8.2, 9.2.1, 9.3.1, 9.3.3,  
 9.4.1, 9.5, 9.6, 9.7.1, 9.8, 9.9, 9.10, 11.1.3, 11.3.1.5,  
 11.3.6, 11.3.10, 12.2, 13.5, 13.7, 14, 15

## Loss of Use Insurance

### 11.3.3

#### Material Suppliers

1.5, 3.12.1, 4.2.4, 4.2.6, 5.2.1, 9.3, 9.4.2, 9.6, 9.10.5

#### Materials, Hazardous

10.2.4, 10.3

#### Materials, Labor, Equipment and

1.1.3, 1.1.6, 1.5.1, 3.4.1, 3.5.1, 3.8.2, 3.8.3, 3.12, 3.13.1, 3.15.1, 4.2.6, 4.2.7, 5.2.1, 6.2.1, 7.3.7, 9.3.2, 9.3.3, 9.5.1.3, 9.10.2, 10.2.1.2, 10.2.4, 14.2.1.1, 14.2.1.2

#### Means, Methods, Techniques, Sequences and Procedures of Construction

3.3.1, 3.12.10, 4.2.2, 4.2.7, 9.4.2

#### Mechanic's Lien

2.1.2, 15.2.8

#### Mediation

8.3.1, 10.3.5, 10.3.6, 15.2.1, 15.2.5, 15.2.6, 15.3, 15.4.1

#### Minor Changes in the Work

1.1.1, 3.12.8, 4.2.8, 7.1, 7.4

## MISCELLANEOUS PROVISIONS

### 13

#### Modifications, Definition of

1.1.1

#### Modifications to the Contract

1.1.1, 1.1.2, 3.11, 4.1.2, 4.2.1, 5.2.3, 7, 8.3.1, 9.7.1, 10.3.2, 11.3.1

#### Mutual Responsibility

6.2

#### Nonconforming Work, Acceptance of

9.6.6, 9.9.3, 12.3

#### Nonconforming Work, Rejection and Correction of

2.3.1, 2.4.1, 3.5.1, 4.2.6, 6.2.4, 9.5.1, 9.8.2, 9.9.3, 9.10.4, 12.2.1

#### Notice

2.2.1, 2.3.1, 2.4.1, 3.2.4, 3.3.1, 3.7.2, 3.12.9, 5.2.1, 9.7.1, 9.10, 10.2.2, 11.1.3, 11.4.6, 12.2.2.1, 13.3, 13.5.1, 13.5.2, 14.1, 14.2, 15.2.8, 15.4.1

#### Notice, Written

2.3.1, 2.4.1, 3.3.1, 3.9.2, 3.12.9, 3.12.10, 5.2.1, 9.7.1, 9.10, 10.2.2, 10.3, 11.1.3, 11.3.6, 12.2.2.1, 13.3, 14, 15.2.8, 15.4.1

#### Notice of Claims

3.7.4, 4.5, 10.2.8, 15.1.2, 15.4

#### Notice of Testing and Inspections

13.5.1, 13.5.2

#### Observations, Contractor's

3.2, 3.7.4

#### Occupancy

2.2.2, 9.6.6, 9.8, 11.3.1.5

#### Orders, Written

1.1.1, 2.3, 3.9.2, 7, 8.2.2, 11.3.9, 12.1, 12.2.2.1, 13.5.2, 14.3.1

## OWNER

2

## Owner, Definition of

### 2.1.1

#### Owner, Information and Services Required of the

2.1.2, 2.2, 3.2.2, 3.12.10, 6.1.3, 6.1.4, 6.2.5, 9.3.2, 9.6.1, 9.6.4, 9.9.2, 9.10.3, 10.3.3, 11.2, 11.3, 13.5.1, 13.5.2, 14.1.1.4, 14.1.4, 15.1.3

#### Owner's Authority

1.5, 2.1.1, 2.3.1, 2.4.1, 3.4.2, 3.8.1, 3.12.10, 3.14.2, 4.1.2, 4.1.3, 4.2.4, 4.2.9, 5.2.1, 5.2.4, 5.4.1, 6.1, 6.3.1, 7.2.1, 7.3.1, 8.2.2, 8.3.1, 9.3.1, 9.3.2, 9.5.1, 9.6.4, 9.9.1, 9.10.2, 10.3.2, 11.1.3, 11.3.3, 11.3.10, 12.2.2, 12.3.1, 13.2.2, 14.3, 14.4, 15.2.7

#### Owner's Financial Capability

2.2.1, 13.2.2, 14.1.1.4

#### Owner's Liability Insurance

11.2

#### Owner's Loss of Use Insurance

11.3.3

#### Owner's Relationship with Subcontractors

1.1.2, 5.2, 5.3, 5.4, 9.6.4, 9.10.2, 14.2.2

#### Owner's Right to Carry Out the Work

2.4, 14.2.2

#### Owner's Right to Clean Up

6.3

#### Owner's Right to Perform Construction and to Award Separate Contracts

6.1

#### Owner's Right to Stop the Work

2.3

#### Owner's Right to Suspend the Work

14.3

#### Owner's Right to Terminate the Contract

14.2

#### Ownership and Use of Drawings, Specifications and Other Instruments of Service

1.1.1, 1.1.6, 1.1.7, 1.5, 2.2.5, 3.2.2, 3.11.1, 3.17.1, 4.2.12, 5.3.1

#### Partial Occupancy or Use

9.6.6, 9.9, 11.3.1.5

#### Patching, Cutting and

3.14, 6.2.5

#### Patents

3.17

#### Payment, Applications for

4.2.5, 7.3.9, 9.2.1, 9.3, 9.4, 9.5, 9.6.3, 9.7.1, 9.8.5, 9.10.1, 14.2.3, 14.2.4, 14.4.3

#### Payment, Certificates for

4.2.5, 4.2.9, 9.3.3, 9.4, 9.5, 9.6.1, 9.6.6, 9.7.1, 9.10.1, 9.10.3, 13.7, 14.1.1.3, 14.2.4

#### Payment, Failure of

9.5.1.3, 9.7, 9.10.2, 13.6, 14.1.1.3, 14.2.1.2

#### Payment, Final

4.2.1, 4.2.9, 9.8.2, 9.10, 11.1.2, 11.1.3, 11.4.1, 11.4.5, 12.3.1, 13.7, 14.2.4, 14.4.3

#### Payment Bond, Performance Bond and

7.3.7.4, 9.6.7, 9.10.3, 11.4.9, 11.4

Init.

**Payments, Progress**  
 9.3, 9.6, 9.8.5, 9.10.3, 13.6, 14.2.3, 15.1.3  
**PAYMENTS AND COMPLETION**  
**9**  
**Payments to Subcontractors**  
 5.4.2, 9.5.1.3, 9.6.2, 9.6.3, 9.6.4, 9.6.7, 11.4.8,  
 14.2.1.2  
**PCB**  
 10.3.1  
**Performance Bond and Payment Bond**  
 7.3.7.4, 9.6.7, 9.10.3, 11.4.9, 11.4  
**Permits, Fees, Notices and Compliance with Laws**  
 2.2.2, 3.7, 3.13, 7.3.7.4, 10.2.2  
**PERSONS AND PROPERTY, PROTECTION OF**  
**10**  
**Polychlorinated Biphenyl**  
 10.3.1  
**Product Data, Definition of**  
**3.12.2**  
**Product Data and Samples, Shop Drawings**  
 3.11, 3.12, 4.2.7  
**Progress and Completion**  
 4.2.2, 8.2, 9.8, 9.9.1, 14.1.4, 15.1.3  
**Progress Payments**  
 9.3, 9.6, 9.8.5, 9.10.3, 13.6, 14.2.3, 15.1.3  
**Project, Definition of the**  
 1.1.4  
**Project Representatives**  
 4.2.10  
**Property Insurance**  
 10.2.5, 11.3  
**PROTECTION OF PERSONS AND PROPERTY**  
**10**  
**Regulations and Laws**  
 1.5, 3.2.3, 3.6, 3.7, 3.12.10, 3.13, 4.1.1, 9.6.4, 9.9.1,  
 10.2.2, 11.1, 11.4, 13.1, 13.4, 13.5.1, 13.5.2, 13.6, 14,  
 15.2.8, 15.4  
**Rejection of Work**  
 3.5.1, 4.2.6, 12.2.1  
**Releases and Waivers of Liens**  
 9.10.2  
**Representations**  
 3.2.1, 3.5.1, 3.12.6, 6.2.2, 8.2.1, 9.3.3, 9.4.2, 9.5.1,  
 9.8.2, 9.10.1  
**Representatives**  
 2.1.1, 3.1.1, 3.9, 4.1.1, 4.2.1, 4.2.2, 4.2.10, 5.1.1, 5.1.2,  
 13.2.1  
**Responsibility for Those Performing the Work**  
 3.3.2, 3.18, 4.2.3, 5.3.1, 6.1.3, 6.2, 6.3, 9.5.1, 10  
**Retainage**  
 9.3.1, 9.6.2, 9.8.5, 9.9.1, 9.10.2, 9.10.3  
**Review of Contract Documents and Field**  
**Conditions by Contractor**  
 3.2, 3.12.7, 6.1.3  
**Review of Contractor's Submittals by Owner and**  
**Architect**  
 3.10.1, 3.10.2, 3.11, 3.12, 4.2, 5.2, 6.1.3, 9.2, 9.8.2

**Review of Shop Drawings, Product Data and Samples**  
**by Contractor**  
 3.12  
**Rights and Remedies**  
 1.1.2, 2.3, 2.4, 3.5.1, 3.7.4, 3.15.2, 4.2.6, 4.5, 5.3, 5.4,  
 6.1, 6.3, 7.3.1, 8.3, 9.5.1, 9.7, 10.2.5, 10.3, 12.2.2,  
 12.2.4, 13.4, 14, 15.4  
**Royalties, Patents and Copyrights**  
**3.17**  
**Rules and Notices for Arbitration**  
 15.4.1  
**Safety of Persons and Property**  
 10.2, 10.4  
**Safety Precautions and Programs**  
 3.3.1, 4.2.2, 4.2.7, 5.3.1, 10.1, 10.2, 10.4  
**Samples, Definition of**  
**3.12.3**  
**Samples, Shop Drawings, Product Data and**  
**3.11, 3.12, 4.2.7**  
**Samples at the Site, Documents and**  
**3.11**  
**Schedule of Values**  
 9.2, 9.3.1  
**Schedules, Construction**  
 3.10, 3.12.1, 3.12.2, 6.1.3, 15.1.5.2  
**Separate Contracts and Contractors**  
 1.1.4, 3.12.5, 3.14.2, 4.2.4, 4.2.7, 6, 8.3.1, 11.4.7,  
 12.1.2  
**Shop Drawings, Definition of**  
**3.12.1**  
**Shop Drawings, Product Data and Samples**  
 3.11, 3.12, 4.2.7  
**Site, Use of**  
**3.13, 6.1.1, 6.2.1**  
**Site Inspections**  
 3.2.2, 3.3.3, 3.7.1, 3.7.4, 4.2, 9.4.2, 9.10.1, 13.5  
**Site Visits, Architect's**  
 3.7.4, 4.2.2, 4.2.9, 9.4.2, 9.5.1, 9.9.2, 9.10.1, 13.5  
**Special Inspections and Testing**  
 4.2.6, 12.2.1, 13.5  
**Specifications, Definition of the**  
**1.1.6**  
**Specifications, The**  
 1.1.1, 1.1.6, 1.2.2, 1.5, 3.11, 3.12.10, 3.17, 4.2.14  
**Statute of Limitations**  
 13.7, 15.4.1.1  
**Stopping the Work**  
 2.3, 9.7, 10.3, 14.1  
**Stored Materials**  
 6.2.1, 9.3.2, 10.2.1.2, 10.2.4, 11.4.1.4  
**Subcontractor, Definition of**  
**5.1.1**  
**SUBCONTRACTORS**  
**5**  
**Subcontractors, Work by**  
 1.2.2, 3.3.2, 3.12.1, 4.2.3, 5.2.3, 5.3, 5.4, 9.3.1.2, 9.6.7

Init.

**Subcontractual Relations**  
5.3, 5.4, 9.3.1.2, 9.6, 9.10, 10.2.1, 11.4.7, 11.4.8, 14.1, 14.2.1

**Submittals**  
3.10, 3.11, 3.12, 4.2.7, 5.2.1, 5.2.3, 7.3.7, 9.2, 9.3, 9.8, 9.9.1, 9.10.2, 9.10.3, 11.1.3

**Submittal Schedule**  
3.10.2, 3.12.5, 4.2.7

**Subrogation, Waivers of**  
6.1.1, 11.4.5, 11.3.7

**Substantial Completion**  
4.2.9, 8.1.1, 8.1.3, 8.2.3, 9.4.2, 9.8, 9.9.1, 9.10.3, 12.2, 13.7

**Substantial Completion, Definition of**  
**9.8.1**

**Substitution of Subcontractors**  
5.2.3, 5.2.4

**Substitution of Architect**  
4.1.3

**Substitutions of Materials**  
3.4.2, 3.5.1, 7.3.8

**Sub-subcontractor, Definition of**  
**5.1.2**

**Subsurface Conditions**  
3.7.4

**Successors and Assigns**  
**13.2**

**Superintendent**  
3.9, 10.2.6

**Supervision and Construction Procedures**  
1.2.2, 3.3, 3.4, 3.12.10, 4.2.2, 4.2.7, 6.1.3, 6.2.4, 7.1.3, 7.3.7, 8.2, 8.3.1, 9.4.2, 10, 12, 14, 15.1.3

**Surety**  
5.4.1.2, 9.8.5, 9.10.2, 9.10.3, 14.2.2, 15.2.7

**Surety, Consent of**  
9.10.2, 9.10.3

**Surveys**  
2.2.3

**Suspension by the Owner for Convenience**  
**14.3**

**Suspension of the Work**  
5.4.2, 14.3

**Suspension or Termination of the Contract**  
5.4.1.1, 11.4.9, 14

**Taxes**  
3.6, 3.8.2.1, 7.3.7.4

**Termination by the Contractor**  
**14.1, 15.1.6**

**Termination by the Owner for Cause**  
5.4.1.1, 14.2, 15.1.6

**Termination by the Owner for Convenience**  
**14.4**

**Termination of the Architect**  
4.1.3

**Termination of the Contractor**  
14.2.2

**TERMINATION OR SUSPENSION OF THE**

**CONTRACT**  
**14**

**Tests and Inspections**  
3.1.3, 3.3.3, 4.2.2, 4.2.6, 4.2.9, 9.4.2, 9.8.3, 9.9.2, 9.10.1, 10.3.2, 11.4.1.1, 12.2.1, 13.5

**TIME**  
**8**

**Time, Delays and Extensions of**  
3.2.4, 3.7.4, 5.2.3, 7.2.1, 7.3.1, 7.4.1, 8.3, 9.5.1, 9.7.1, 10.3.2, 10.4.1, 14.3.2, 15.1.5, 15.2.5

**Time Limits**  
2.1.2, 2.2, 2.4, 3.2.2, 3.10, 3.11, 3.12.5, 3.15.1, 4.2, 4.4, 4.5, 5.2, 5.3, 5.4, 6.2.4, 7.3, 7.4, 8.2, 9.2, 9.3.1, 9.3.3, 9.4.1, 9.5, 9.6, 9.7, 9.8, 9.9, 9.10, 11.1.3, 11.4.1.5, 11.4.6, 11.4.10, 12.2, 13.5, 13.7, 14, 15.1.2, 15.4

**Time Limits on Claims**  
3.7.4, 10.2.8, 13.7, 15.1.2

**Title to Work**  
9.3.2, 9.3.3

**Transmission of Data in Digital Form**  
**1.6**

**UNCOVERING AND CORRECTION OF WORK**  
**12**

**Uncovering of Work**  
**12.1**

**Unforeseen Conditions, Concealed or Unknown**  
3.7.4, 8.3.1, 10.3

**Unit Prices**  
7.3.3.2, 7.3.4

**Use of Documents**  
1.1.1, 1.5, 2.2.5, 3.12.6, 5.3

**Use of Site**  
**3.13, 6.1.1, 6.2.1**

**Values, Schedule of**  
**9.2, 9.3.1**

**Waiver of Claims by the Architect**  
13.4.2

**Waiver of Claims by the Contractor**  
9.10.5, 11.4.7, 13.4.2, 15.1.6

**Waiver of Claims by the Owner**  
9.9.3, 9.10.3, 9.10.4, 11.4.3, 11.4.5, 11.4.7, 12.2.2.1, 13.4.2, 14.2.4, 15.1.6

**Waiver of Consequential Damages**  
14.2.4, 15.1.6

**Waiver of Liens**  
9.10.2, 9.10.4

**Waivers of Subrogation**  
6.1.1, 11.4.5, 11.3.7

**Warranty**  
3.5, 4.2.9, 9.3.3, 9.8.4, 9.9.1, 9.10.4, 12.2.2, 13.7.1

**Weather Delays**  
15.1.5.2

**Work, Definition of**  
**1.1.3**

Init.

**Written Consent**

1.5.2, 3.4.2, 3.7.4, 3.12.8, 3.14.2, 4.1.2, 9.3.2, 9.8.5,  
9.9.1, 9.10.2, 9.10.3, 11.4.1, 13.2, 13.4.2, 15.4.4.2

**Written Interpretations**

4.2.11, 4.2.12

**Written Notice**

2.3, 2.4, 3.3.1, 3.9, 3.12.9, 3.12.10, 5.2.1, 8.2.2, 9.7,  
9.10, 10.2.2, 10.3, 11.1.3, 11.4.6, 12.2.2, 12.2.4, 13.3,  
14, 15.4.1

**Written Orders**

1.1.1, 2.3, 3.9, 7, 8.2.2, 11.4.9, 12.1, 12.2, 13.5.2,  
14.3.1, 15.1.2

Init.

## **ARTICLE 1 GENERAL PROVISIONS**

### **§ 1.1 BASIC DEFINITIONS**

#### **§ 1.1.1 THE CONTRACT DOCUMENTS**

The Contract Documents are enumerated in the Agreement between the Owner and Contractor (hereinafter the Agreement) and consist of the Agreement, Conditions of the Contract (General, Supplementary and other Conditions), Drawings, Specifications, Addenda issued prior to execution of the Contract, other documents listed in the Agreement and Modifications issued after execution of the Contract. A Modification is (1) a written amendment to the Contract signed by both parties, (2) a Change Order, (3) a Construction Change Directive or (4) a written order for a minor change in the Work issued by the Architect. Unless specifically enumerated in the Agreement, the Contract Documents do not include the advertisement or invitation to bid, Instructions to Bidders, sample forms, other information furnished by the Owner in anticipation of receiving bids or proposals, the Contractor's bid or proposal, or portions of Addenda relating to bidding requirements.

#### **§ 1.1.2 THE CONTRACT**

The Contract Documents form the Contract for Construction. The Contract represents the entire and integrated agreement between the parties hereto and supersedes prior negotiations, representations or agreements, either written or oral. The Contract may be amended or modified only by a Modification. The Contract Documents shall not be construed to create a contractual relationship of any kind (1) between the Contractor and the Architect or the Architect's consultants, (2) between the Owner and a Subcontractor or a Sub-subcontractor, (3) between the Owner and the Architect or the Architect's consultants or (4) between any persons or entities other than the Owner and the Contractor. The Architect shall, however, be entitled to performance and enforcement of obligations under the Contract intended to facilitate performance of the Architect's duties.

#### **§ 1.1.3 THE WORK**

The term "Work" means the construction and services required by the Contract Documents, whether completed or partially completed, and includes all other labor, materials, equipment and services provided or to be provided by the Contractor to fulfill the Contractor's obligations. The Work may constitute the whole or a part of the Project.

#### **§ 1.1.4 THE PROJECT**

The Project is the total construction of which the Work performed under the Contract Documents may be the whole or a part and which may include construction by the Owner and by separate contractors.

#### **§ 1.1.5 THE DRAWINGS**

The Drawings are the graphic and pictorial portions of the Contract Documents showing the design, location and dimensions of the Work, generally including plans, elevations, sections, details, schedules and diagrams.

#### **§ 1.1.6 THE SPECIFICATIONS**

The Specifications are that portion of the Contract Documents consisting of the written requirements for materials, equipment, systems, standards and workmanship for the Work, and performance of related services.

#### **§ 1.1.7 INSTRUMENTS OF SERVICE**

Instruments of Service are representations, in any medium of expression now known or later developed, of the tangible and intangible creative work performed by the Architect and the Architect's consultants under their respective professional services agreements. Instruments of Service may include, without limitation, studies, surveys, models, sketches, drawings, specifications, and other similar materials.

#### **§ 1.1.8 INITIAL DECISION MAKER**

The Initial Decision Maker is the person identified in the Agreement to render initial decisions on Claims in accordance with Section 15.2 and certify termination of the Agreement under Section 14.2.2.

### **§ 1.2 CORRELATION AND INTENT OF THE CONTRACT DOCUMENTS**

**§ 1.2.1** The intent of the Contract Documents is to include all items necessary for the proper execution and completion of the Work by the Contractor. The Contract Documents are complementary, and what is required by one shall be as binding as if required by all; performance by the Contractor shall be required only to the extent consistent with the Contract Documents and reasonably inferable from them as being necessary to produce the indicated results.

§ 1.2.2 Organization of the Specifications into divisions, sections and articles, and arrangement of Drawings shall not control the Contractor in dividing the Work among Subcontractors or in establishing the extent of Work to be performed by any trade.

§ 1.2.3 Unless otherwise stated in the Contract Documents, words that have well-known technical or construction industry meanings are used in the Contract Documents in accordance with such recognized meanings.

### § 1.3 CAPITALIZATION

Terms capitalized in these General Conditions include those that are (1) specifically defined, (2) the titles of numbered articles or (3) the titles of other documents published by the American Institute of Architects.

### § 1.4 INTERPRETATION

In the interest of brevity the Contract Documents frequently omit modifying words such as "all" and "any" and articles such as "the" and "an," but the fact that a modifier or an article is absent from one statement and appears in another is not intended to affect the interpretation of either statement.

### § 1.5 OWNERSHIP AND USE OF DRAWINGS, SPECIFICATIONS AND OTHER INSTRUMENTS OF SERVICE

§ 1.5.1 The Architect and the Architect's consultants shall be deemed the authors and owners of their respective Instruments of Service, including the Drawings and Specifications, and will retain all common law, statutory and other reserved rights, including copyrights. The Contractor, Subcontractors, Sub-subcontractors, and material or equipment suppliers shall not own or claim a copyright in the Instruments of Service. Submittal or distribution to meet official regulatory requirements or for other purposes in connection with this Project is not to be construed as publication in derogation of the Architect's or Architect's consultants' reserved rights.

§ 1.5.2 The Contractor, Subcontractors, Sub-subcontractors and material or equipment suppliers are authorized to use and reproduce the Instruments of Service provided to them solely and exclusively for execution of the Work. All copies made under this authorization shall bear the copyright notice, if any, shown on the Instruments of Service. The Contractor, Subcontractors, Sub-subcontractors, and material or equipment suppliers may not use the Instruments of Service on other projects or for additions to this Project outside the scope of the Work without the specific written consent of the Owner, Architect and the Architect's consultants.

### § 1.6 TRANSMISSION OF DATA IN DIGITAL FORM

If the parties intend to transmit Instruments of Service or any other information or documentation in digital form, they shall endeavor to establish necessary protocols governing such transmissions, unless otherwise already provided in the Agreement or the Contract Documents.

## ARTICLE 2 OWNER

### § 2.1 GENERAL

§ 2.1.1 The Owner is the person or entity identified as such in the Agreement and is referred to throughout the Contract Documents as if singular in number. The Owner shall designate in writing a representative who shall have express authority to bind the Owner with respect to all matters requiring the Owner's approval or authorization. Except as otherwise provided in Section 4.2.1, the Architect does not have such authority. The term "Owner" means the Owner or the Owner's authorized representative.

§ 2.1.2 The Owner shall furnish to the Contractor within fifteen days after receipt of a written request, information necessary and relevant for the Contractor to evaluate, give notice of or enforce mechanic's lien rights. Such information shall include a correct statement of the record legal title to the property on which the Project is located, usually referred to as the site, and the Owner's interest therein.

### § 2.2 INFORMATION AND SERVICES REQUIRED OF THE OWNER

§ 2.2.1 Prior to commencement of the Work, the Contractor may request in writing that the Owner provide reasonable evidence that the Owner has made financial arrangements to fulfill the Owner's obligations under the Contract. Thereafter, the Contractor may only request such evidence if (1) the Owner fails to make payments to the Contractor as the Contract Documents require; (2) a change in the Work materially changes the Contract Sum; or (3) the Contractor identifies in writing a reasonable concern regarding the Owner's ability to make payment when due. The Owner shall furnish such evidence as a condition precedent to commencement or continuation of the Work or the

portion of the Work affected by a material change. After the Owner furnishes the evidence, the Owner shall not materially vary such financial arrangements without prior notice to the Contractor.

§ 2.2.2 Except for permits and fees that are the responsibility of the Contractor under the Contract Documents, including those required under Section 3.7.1, the Owner shall secure and pay for necessary approvals, easements, assessments and charges required for construction, use or occupancy of permanent structures or for permanent changes in existing facilities.

§ 2.2.3 The Owner shall furnish surveys describing physical characteristics, legal limitations and utility locations for the site of the Project, and a legal description of the site. The Contractor shall be entitled to rely on the accuracy of information furnished by the Owner but shall exercise proper precautions relating to the safe performance of the Work.

§ 2.2.4 The Owner shall furnish information or services required of the Owner by the Contract Documents with reasonable promptness. The Owner shall also furnish any other information or services under the Owner's control and relevant to the Contractor's performance of the Work with reasonable promptness after receiving the Contractor's written request for such information or services.

§ 2.2.5 Unless otherwise provided in the Contract Documents, the Owner shall furnish to the Contractor one copy of the Contract Documents for purposes of making reproductions pursuant to Section 1.5.2.

### § 2.3 OWNER'S RIGHT TO STOP THE WORK

If the Contractor fails to correct Work that is not in accordance with the requirements of the Contract Documents as required by Section 12.2 or repeatedly fails to carry out Work in accordance with the Contract Documents, the Owner may issue a written order to the Contractor to stop the Work, or any portion thereof, until the cause for such order has been eliminated; however, the right of the Owner to stop the Work shall not give rise to a duty on the part of the Owner to exercise this right for the benefit of the Contractor or any other person or entity, except to the extent required by Section 6.1.3.

### § 2.4 OWNER'S RIGHT TO CARRY OUT THE WORK

If the Contractor defaults or neglects to carry out the Work in accordance with the Contract Documents and fails within a ten-day period after receipt of written notice from the Owner to commence and continue correction of such default or neglect with diligence and promptness, the Owner may, without prejudice to other remedies the Owner may have, correct such deficiencies. In such case an appropriate Change Order shall be issued deducting from payments then or thereafter due the Contractor the reasonable cost of correcting such deficiencies, including Owner's expenses and compensation for the Architect's additional services made necessary by such default, neglect or failure. Such action by the Owner and amounts charged to the Contractor are both subject to prior approval of the Architect. If payments then or thereafter due the Contractor are not sufficient to cover such amounts, the Contractor shall pay the difference to the Owner.

## ARTICLE 3 CONTRACTOR

### § 3.1 GENERAL

§ 3.1.1 The Contractor is the person or entity identified as such in the Agreement and is referred to throughout the Contract Documents as if singular in number. The Contractor shall be lawfully licensed, if required in the jurisdiction where the Project is located. The Contractor shall designate in writing a representative who shall have express authority to bind the Contractor with respect to all matters under this Contract. The term "Contractor" means the Contractor or the Contractor's authorized representative.

§ 3.1.2 The Contractor shall perform the Work in accordance with the Contract Documents.

§ 3.1.3 The Contractor shall not be relieved of obligations to perform the Work in accordance with the Contract Documents either by activities or duties of the Architect in the Architect's administration of the Contract, or by tests, inspections or approvals required or performed by persons or entities other than the Contractor.

Init.



## **§ 3.2 REVIEW OF CONTRACT DOCUMENTS AND FIELD CONDITIONS BY CONTRACTOR**

**§ 3.2.1** Execution of the Contract by the Contractor is a representation that the Contractor has visited the site, become generally familiar with local conditions under which the Work is to be performed and correlated personal observations with requirements of the Contract Documents.

**§ 3.2.2** Because the Contract Documents are complementary, the Contractor shall, before starting each portion of the Work, carefully study and compare the various Contract Documents relative to that portion of the Work, as well as the information furnished by the Owner pursuant to Section 2.2.3, shall take field measurements of any existing conditions related to that portion of the Work, and shall observe any conditions at the site affecting it. These obligations are for the purpose of facilitating coordination and construction by the Contractor and are not for the purpose of discovering errors, omissions, or inconsistencies in the Contract Documents; however, the Contractor shall promptly report to the Architect any errors, inconsistencies or omissions discovered by or made known to the Contractor as a request for information in such form as the Architect may require. It is recognized that the Contractor's review is made in the Contractor's capacity as a contractor and not as a licensed design professional, unless otherwise specifically provided in the Contract Documents.

**§ 3.2.3** The Contractor is not required to ascertain that the Contract Documents are in accordance with applicable laws, statutes, ordinances, codes, rules and regulations, or lawful orders of public authorities, but the Contractor shall promptly report to the Architect any nonconformity discovered by or made known to the Contractor as a request for information in such form as the Architect may require.

**§ 3.2.4** If the Contractor believes that additional cost or time is involved because of clarifications or instructions the Architect issues in response to the Contractor's notices or requests for information pursuant to Sections 3.2.2 or 3.2.3, the Contractor shall make Claims as provided in Article 15. If the Contractor fails to perform the obligations of Sections 3.2.2 or 3.2.3, the Contractor shall pay such costs and damages to the Owner as would have been avoided if the Contractor had performed such obligations. If the Contractor performs those obligations, the Contractor shall not be liable to the Owner or Architect for damages resulting from errors, inconsistencies or omissions in the Contract Documents, for differences between field measurements or conditions and the Contract Documents, or for nonconformities of the Contract Documents to applicable laws, statutes, ordinances, codes, rules and regulations, and lawful orders of public authorities.

## **§ 3.3 SUPERVISION AND CONSTRUCTION PROCEDURES**

**§ 3.3.1** The Contractor shall supervise and direct the Work, using the Contractor's best skill and attention. The Contractor shall be solely responsible for, and have control over, construction means, methods, techniques, sequences and procedures and for coordinating all portions of the Work under the Contract, unless the Contract Documents give other specific instructions concerning these matters. If the Contract Documents give specific instructions concerning construction means, methods, techniques, sequences or procedures, the Contractor shall evaluate the jobsite safety thereof and, except as stated below, shall be fully and solely responsible for the jobsite safety of such means, methods, techniques, sequences or procedures. If the Contractor determines that such means, methods, techniques, sequences or procedures may not be safe, the Contractor shall give timely written notice to the Owner and Architect and shall not proceed with that portion of the Work without further written instructions from the Architect. If the Contractor is then instructed to proceed with the required means, methods, techniques, sequences or procedures without acceptance of changes proposed by the Contractor, the Owner shall be solely responsible for any loss or damage arising solely from those Owner-required means, methods, techniques, sequences or procedures.

**§ 3.3.2** The Contractor shall be responsible to the Owner for acts and omissions of the Contractor's employees, Subcontractors and their agents and employees, and other persons or entities performing portions of the Work for, or on behalf of, the Contractor or any of its Subcontractors.

**§ 3.3.3** The Contractor shall be responsible for inspection of portions of Work already performed to determine that such portions are in proper condition to receive subsequent Work.

## **§ 3.4 LABOR AND MATERIALS**

**§ 3.4.1** Unless otherwise provided in the Contract Documents, the Contractor shall provide and pay for labor, materials, equipment, tools, construction equipment and machinery, water, heat, utilities, transportation, and other facilities and services necessary for proper execution and completion of the Work, whether temporary or permanent and whether or not incorporated or to be incorporated in the Work.

Init.

§ 3.4.2 Except in the case of minor changes in the Work authorized by the Architect in accordance with Sections 3.12.8 or 7.4, the Contractor may make substitutions only with the consent of the Owner, after evaluation by the Architect and in accordance with a Change Order or Construction Change Directive.

§ 3.4.3 The Contractor shall enforce strict discipline and good order among the Contractor's employees and other persons carrying out the Work. The Contractor shall not permit employment of unfit persons or persons not properly skilled in tasks assigned to them.

### § 3.5 WARRANTY

The Contractor warrants to the Owner and Architect that materials and equipment furnished under the Contract will be of good quality and new unless the Contract Documents require or permit otherwise. The Contractor further warrants that the Work will conform to the requirements of the Contract Documents and will be free from defects, except for those inherent in the quality of the Work the Contract Documents require or permit. Work, materials, or equipment not conforming to these requirements may be considered defective. The Contractor's warranty excludes remedy for damage or defect caused by abuse, alterations to the Work not executed by the Contractor, improper or insufficient maintenance, improper operation, or normal wear and tear and normal usage. If required by the Architect, the Contractor shall furnish satisfactory evidence as to the kind and quality of materials and equipment.

### § 3.6 TAXES

The Contractor shall pay sales, consumer, use and similar taxes for the Work provided by the Contractor that are legally enacted when bids are received or negotiations concluded, whether or not yet effective or merely scheduled to go into effect.

### § 3.7 PERMITS, FEES, NOTICES, AND COMPLIANCE WITH LAWS

§ 3.7.1 Unless otherwise provided in the Contract Documents, the Contractor shall secure and pay for the building permit as well as for other permits, fees, licenses, and inspections by government agencies necessary for proper execution and completion of the Work that are customarily secured after execution of the Contract and legally required at the time bids are received or negotiations concluded.

§ 3.7.2 The Contractor shall comply with and give notices required by applicable laws, statutes, ordinances, codes, rules and regulations, and lawful orders of public authorities applicable to performance of the Work.

§ 3.7.3 If the Contractor performs Work knowing it to be contrary to applicable laws, statutes, ordinances, codes, rules and regulations, or lawful orders of public authorities, the Contractor shall assume appropriate responsibility for such Work and shall bear the costs attributable to correction.

§ 3.7.4 **Concealed or Unknown Conditions.** If the Contractor encounters conditions at the site that are (1) subsurface or otherwise concealed physical conditions that differ materially from those indicated in the Contract Documents or (2) unknown physical conditions of an unusual nature, that differ materially from those ordinarily found to exist and generally recognized as inherent in construction activities of the character provided for in the Contract Documents, the Contractor shall promptly provide notice to the Owner and the Architect before conditions are disturbed and in no event later than 21 days after first observance of the conditions. The Architect will promptly investigate such conditions and, if the Architect determines that they differ materially and cause an increase or decrease in the Contractor's cost of, or time required for, performance of any part of the Work, will recommend an equitable adjustment in the Contract Sum or Contract Time, or both. If the Architect determines that the conditions at the site are not materially different from those indicated in the Contract Documents and that no change in the terms of the Contract is justified, the Architect shall promptly notify the Owner and Contractor in writing, stating the reasons. If either party disputes the Architect's determination or recommendation, that party may proceed as provided in Article 15.

§ 3.7.5 If, in the course of the Work, the Contractor encounters human remains or recognizes the existence of burial markers, archaeological sites or wetlands not indicated in the Contract Documents, the Contractor shall immediately suspend any operations that would affect them and shall notify the Owner and Architect. Upon receipt of such notice, the Owner shall promptly take any action necessary to obtain governmental authorization required to resume the operations. The Contractor shall continue to suspend such operations until otherwise instructed by the Owner but shall continue with all other operations that do not affect those remains or features. Requests for adjustments in the Contract Sum and Contract Time arising from the existence of such remains or features may be made as provided in Article 15.

### § 3.8 ALLOWANCES

§ 3.8.1 The Contractor shall include in the Contract Sum all allowances stated in the Contract Documents. Items covered by allowances shall be supplied for such amounts and by such persons or entities as the Owner may direct, but the Contractor shall not be required to employ persons or entities to whom the Contractor has reasonable objection.

§ 3.8.2 Unless otherwise provided in the Contract Documents,

- .1 allowances shall cover the cost to the Contractor of materials and equipment delivered at the site and all required taxes, less applicable trade discounts;
- .2 Contractor's costs for unloading and handling at the site, labor, installation costs, overhead, profit and other expenses contemplated for stated allowance amounts shall be included in the Contract Sum but not in the allowances; and
- .3 whenever costs are more than or less than allowances, the Contract Sum shall be adjusted accordingly by Change Order. The amount of the Change Order shall reflect (1) the difference between actual costs and the allowances under Section 3.8.2.1 and (2) changes in Contractor's costs under Section 3.8.2.2.

§ 3.8.3 Materials and equipment under an allowance shall be selected by the Owner with reasonable promptness.

### § 3.9 SUPERINTENDENT

§ 3.9.1 The Contractor shall employ a competent superintendent and necessary assistants who shall be in attendance at the Project site during performance of the Work. The superintendent shall represent the Contractor, and communications given to the superintendent shall be as binding as if given to the Contractor.

§ 3.9.2 The Contractor, as soon as practicable after award of the Contract, shall furnish in writing to the Owner through the Architect the name and qualifications of a proposed superintendent. The Architect may reply within 14 days to the Contractor in writing stating (1) whether the Owner or the Architect has reasonable objection to the proposed superintendent or (2) that the Architect requires additional time to review. Failure of the Architect to reply within the 14 day period shall constitute notice of no reasonable objection.

§ 3.9.3 The Contractor shall not employ a proposed superintendent to whom the Owner or Architect has made reasonable and timely objection. The Contractor shall not change the superintendent without the Owner's consent, which shall not unreasonably be withheld or delayed.

### § 3.10 CONTRACTOR'S CONSTRUCTION SCHEDULES

§ 3.10.1 The Contractor, promptly after being awarded the Contract, shall prepare and submit for the Owner's and Architect's information a Contractor's construction schedule for the Work. The schedule shall not exceed time limits current under the Contract Documents, shall be revised at appropriate intervals as required by the conditions of the Work and Project, shall be related to the entire Project to the extent required by the Contract Documents, and shall provide for expeditious and practicable execution of the Work.

§ 3.10.2 The Contractor shall prepare a submittal schedule, promptly after being awarded the Contract and thereafter as necessary to maintain a current submittal schedule, and shall submit the schedule(s) for the Architect's approval. The Architect's approval shall not unreasonably be delayed or withheld. The submittal schedule shall (1) be coordinated with the Contractor's construction schedule, and (2) allow the Architect reasonable time to review submittals. If the Contractor fails to submit a submittal schedule, the Contractor shall not be entitled to any increase in Contract Sum or extension of Contract Time based on the time required for review of submittals.

§ 3.10.3 The Contractor shall perform the Work in general accordance with the most recent schedules submitted to the Owner and Architect.

### § 3.11 DOCUMENTS AND SAMPLES AT THE SITE

The Contractor shall maintain at the site for the Owner one copy of the Drawings, Specifications, Addenda, Change Orders and other Modifications, in good order and marked currently to indicate field changes and selections made during construction, and one copy of approved Shop Drawings, Product Data, Samples and similar required submittals. These shall be available to the Architect and shall be delivered to the Architect for submittal to the Owner upon completion of the Work as a record of the Work as constructed.

Init.

### § 3.12 SHOP DRAWINGS, PRODUCT DATA AND SAMPLES

§ 3.12.1 Shop Drawings are drawings, diagrams, schedules and other data specially prepared for the Work by the Contractor or a Subcontractor, Sub-subcontractor, manufacturer, supplier or distributor to illustrate some portion of the Work.

§ 3.12.2 Product Data are illustrations, standard schedules, performance charts, instructions, brochures, diagrams and other information furnished by the Contractor to illustrate materials or equipment for some portion of the Work.

§ 3.12.3 Samples are physical examples that illustrate materials, equipment or workmanship and establish standards by which the Work will be judged.

§ 3.12.4 Shop Drawings, Product Data, Samples and similar submittals are not Contract Documents. Their purpose is to demonstrate the way by which the Contractor proposes to conform to the information given and the design concept expressed in the Contract Documents for those portions of the Work for which the Contract Documents require submittals. Review by the Architect is subject to the limitations of Section 4.2.7. Informational submittals upon which the Architect is not expected to take responsive action may be so identified in the Contract Documents. Submittals that are not required by the Contract Documents may be returned by the Architect without action.

§ 3.12.5 The Contractor shall review for compliance with the Contract Documents, approve and submit to the Architect Shop Drawings, Product Data, Samples and similar submittals required by the Contract Documents in accordance with the submittal schedule approved by the Architect or, in the absence of an approved submittal schedule, with reasonable promptness and in such sequence as to cause no delay in the Work or in the activities of the Owner or of separate contractors.

§ 3.12.6 By submitting Shop Drawings, Product Data, Samples and similar submittals, the Contractor represents to the Owner and Architect that the Contractor has (1) reviewed and approved them, (2) determined and verified materials, field measurements and field construction criteria related thereto, or will do so and (3) checked and coordinated the information contained within such submittals with the requirements of the Work and of the Contract Documents.

§ 3.12.7 The Contractor shall perform no portion of the Work for which the Contract Documents require submittal and review of Shop Drawings, Product Data, Samples or similar submittals until the respective submittal has been approved by the Architect.

§ 3.12.8 The Work shall be in accordance with approved submittals except that the Contractor shall not be relieved of responsibility for deviations from requirements of the Contract Documents by the Architect's approval of Shop Drawings, Product Data, Samples or similar submittals unless the Contractor has specifically informed the Architect in writing of such deviation at the time of submittal and (1) the Architect has given written approval to the specific deviation as a minor change in the Work, or (2) a Change Order or Construction Change Directive has been issued authorizing the deviation. The Contractor shall not be relieved of responsibility for errors or omissions in Shop Drawings, Product Data, Samples or similar submittals by the Architect's approval thereof.

§ 3.12.9 The Contractor shall direct specific attention, in writing or on resubmitted Shop Drawings, Product Data, Samples or similar submittals, to revisions other than those requested by the Architect on previous submittals. In the absence of such written notice, the Architect's approval of a resubmission shall not apply to such revisions.

§ 3.12.10 The Contractor shall not be required to provide professional services that constitute the practice of architecture or engineering unless such services are specifically required by the Contract Documents for a portion of the Work or unless the Contractor needs to provide such services in order to carry out the Contractor's responsibilities for construction means, methods, techniques, sequences and procedures. The Contractor shall not be required to provide professional services in violation of applicable law. If professional design services or certifications by a design professional related to systems, materials or equipment are specifically required of the Contractor by the Contract Documents, the Owner and the Architect will specify all performance and design criteria that such services must satisfy. The Contractor shall cause such services or certifications to be provided by a properly licensed design professional, whose signature and seal shall appear on all drawings, calculations, specifications, certifications, Shop Drawings and other submittals prepared by such professional. Shop Drawings and other submittals related to the Work designed or certified by such professional, if prepared by others, shall bear such professional's written approval when submitted to the Architect. The Owner and the Architect shall be entitled to rely upon the adequacy, accuracy and

Init.

completeness of the services, certifications and approvals performed or provided by such design professionals, provided the Owner and Architect have specified to the Contractor all performance and design criteria that such services must satisfy. Pursuant to this Section 3.12.10, the Architect will review, approve or take other appropriate action on submittals only for the limited purpose of checking for conformance with information given and the design concept expressed in the Contract Documents. The Contractor shall not be responsible for the adequacy of the performance and design criteria specified in the Contract Documents.

### **§ 3.13 USE OF SITE**

The Contractor shall confine operations at the site to areas permitted by applicable laws, statutes, ordinances, codes, rules and regulations, and lawful orders of public authorities and the Contract Documents and shall not unreasonably encumber the site with materials or equipment.

### **§ 3.14 CUTTING AND PATCHING**

**§ 3.14.1** The Contractor shall be responsible for cutting, fitting or patching required to complete the Work or to make its parts fit together properly. All areas requiring cutting, fitting and patching shall be restored to the condition existing prior to the cutting, fitting and patching, unless otherwise required by the Contract Documents.

**§ 3.14.2** The Contractor shall not damage or endanger a portion of the Work or fully or partially completed construction of the Owner or separate contractors by cutting, patching or otherwise altering such construction, or by excavation. The Contractor shall not cut or otherwise alter such construction by the Owner or a separate contractor except with written consent of the Owner and of such separate contractor; such consent shall not be unreasonably withheld. The Contractor shall not unreasonably withhold from the Owner or a separate contractor the Contractor's consent to cutting or otherwise altering the Work.

### **§ 3.15 CLEANING UP**

**§ 3.15.1** The Contractor shall keep the premises and surrounding area free from accumulation of waste materials or rubbish caused by operations under the Contract. At completion of the Work, the Contractor shall remove waste materials, rubbish, the Contractor's tools, construction equipment, machinery and surplus materials from and about the Project.

**§ 3.15.2** If the Contractor fails to clean up as provided in the Contract Documents, the Owner may do so and Owner shall be entitled to reimbursement from the Contractor.

### **§ 3.16 ACCESS TO WORK**

The Contractor shall provide the Owner and Architect access to the Work in preparation and progress wherever located.

### **§ 3.17 ROYALTIES, PATENTS AND COPYRIGHTS**

The Contractor shall pay all royalties and license fees. The Contractor shall defend suits or claims for infringement of copyrights and patent rights and shall hold the Owner and Architect harmless from loss on account thereof, but shall not be responsible for such defense or loss when a particular design, process or product of a particular manufacturer or manufacturers is required by the Contract Documents, or where the copyright violations are contained in Drawings, Specifications or other documents prepared by the Owner or Architect. However, if the Contractor has reason to believe that the required design, process or product is an infringement of a copyright or a patent, the Contractor shall be responsible for such loss unless such information is promptly furnished to the Architect.

### **§ 3.18 INDEMNIFICATION**

**§ 3.18.1** To the fullest extent permitted by law the Contractor shall indemnify and hold harmless the Owner, Architect, Architect's consultants, and agents and employees of any of them from and against claims, damages, losses and expenses, including but not limited to attorneys' fees, arising out of or resulting from performance of the Work, provided that such claim, damage, loss or expense is attributable to bodily injury, sickness, disease or death, or to injury to or destruction of tangible property (other than the Work itself), but only to the extent caused by the negligent acts or omissions of the Contractor, a Subcontractor, anyone directly or indirectly employed by them or anyone for whose acts they may be liable, regardless of whether or not such claim, damage, loss or expense is caused in part by a party indemnified hereunder. Such obligation shall not be construed to negate, abridge, or reduce other rights or obligations of indemnity which would otherwise exist as to a party or person described in this Section 3.18.

Init.

§ 3.18.2 In claims against any person or entity indemnified under this Section 3.18 by an employee of the Contractor, a Subcontractor, anyone directly or indirectly employed by them or anyone for whose acts they may be liable, the indemnification obligation under Section 3.18.1 shall not be limited by a limitation on amount or type of damages, compensation or benefits payable by or for the Contractor or a Subcontractor under workers' compensation acts, disability benefit acts or other employee benefit acts.

#### ARTICLE 4 ARCHITECT

##### § 4.1 GENERAL

§ 4.1.1 The Owner shall retain an architect lawfully licensed to practice architecture or an entity lawfully practicing architecture in the jurisdiction where the Project is located. That person or entity is identified as the Architect in the Agreement and is referred to throughout the Contract Documents as if singular in number.

§ 4.1.2 Duties, responsibilities and limitations of authority of the Architect as set forth in the Contract Documents shall not be restricted, modified or extended without written consent of the Owner, Contractor and Architect. Consent shall not be unreasonably withheld.

§ 4.1.3 If the employment of the Architect is terminated, the Owner shall employ a successor architect as to whom the Contractor has no reasonable objection and whose status under the Contract Documents shall be that of the Architect.

##### § 4.2 ADMINISTRATION OF THE CONTRACT

§ 4.2.1 The Architect will provide administration of the Contract as described in the Contract Documents and will be an Owner's representative during construction until the date the Architect issues the final Certificate For Payment. The Architect will have authority to act on behalf of the Owner only to the extent provided in the Contract Documents.

§ 4.2.2 The Architect will visit the site at intervals appropriate to the stage of construction, or as otherwise agreed with the Owner, to become generally familiar with the progress and quality of the portion of the Work completed, and to determine in general if the Work observed is being performed in a manner indicating that the Work, when fully completed, will be in accordance with the Contract Documents. However, the Architect will not be required to make exhaustive or continuous on-site inspections to check the quality or quantity of the Work. The Architect will not have control over, charge of, or responsibility for, the construction means, methods, techniques, sequences or procedures, or for the safety precautions and programs in connection with the Work, since these are solely the Contractor's rights and responsibilities under the Contract Documents, except as provided in Section 3.3.1.

§ 4.2.3 On the basis of the site visits, the Architect will keep the Owner reasonably informed about the progress and quality of the portion of the Work completed, and report to the Owner (1) known deviations from the Contract Documents and from the most recent construction schedule submitted by the Contractor, and (2) defects and deficiencies observed in the Work. The Architect will not be responsible for the Contractor's failure to perform the Work in accordance with the requirements of the Contract Documents. The Architect will not have control over or charge of and will not be responsible for acts or omissions of the Contractor, Subcontractors, or their agents or employees, or any other persons or entities performing portions of the Work.

##### § 4.2.4 COMMUNICATIONS FACILITATING CONTRACT ADMINISTRATION

Except as otherwise provided in the Contract Documents or when direct communications have been specially authorized, the Owner and Contractor shall endeavor to communicate with each other through the Architect about matters arising out of or relating to the Contract. Communications by and with the Architect's consultants shall be through the Architect. Communications by and with Subcontractors and material suppliers shall be through the Contractor. Communications by and with separate contractors shall be through the Owner.

§ 4.2.5 Based on the Architect's evaluations of the Contractor's Applications for Payment, the Architect will review and certify the amounts due the Contractor and will issue Certificates for Payment in such amounts.

§ 4.2.6 The Architect has authority to reject Work that does not conform to the Contract Documents. Whenever the Architect considers it necessary or advisable, the Architect will have authority to require inspection or testing of the Work in accordance with Sections 13.5.2 and 13.5.3, whether or not such Work is fabricated, installed or completed. However, neither this authority of the Architect nor a decision made in good faith either to exercise or not to exercise such authority shall give rise to a duty or responsibility of the Architect to the Contractor, Subcontractors, material and equipment suppliers, their agents or employees, or other persons or entities performing portions of the Work.

§ 4.2.7 The Architect will review and approve, or take other appropriate action upon, the Contractor's submittals such as Shop Drawings, Product Data and Samples, but only for the limited purpose of checking for conformance with information given and the design concept expressed in the Contract Documents. The Architect's action will be taken in accordance with the submittal schedule approved by the Architect or, in the absence of an approved submittal schedule, with reasonable promptness while allowing sufficient time in the Architect's professional judgment to permit adequate review. Review of such submittals is not conducted for the purpose of determining the accuracy and completeness of other details such as dimensions and quantities, or for substantiating instructions for installation or performance of equipment or systems, all of which remain the responsibility of the Contractor as required by the Contract Documents. The Architect's review of the Contractor's submittals shall not relieve the Contractor of the obligations under Sections 3.3, 3.5 and 3.12. The Architect's review shall not constitute approval of safety precautions or, unless otherwise specifically stated by the Architect, of any construction means, methods, techniques, sequences or procedures. The Architect's approval of a specific item shall not indicate approval of an assembly of which the item is a component.

§ 4.2.8 The Architect will prepare Change Orders and Construction Change Directives, and may authorize minor changes in the Work as provided in Section 7.4. The Architect will investigate and make determinations and recommendations regarding concealed and unknown conditions as provided in Section 3.7.4.

§ 4.2.9 The Architect will conduct inspections to determine the date or dates of Substantial Completion and the date of final completion; issue Certificates of Substantial Completion pursuant to Section 9.8; receive and forward to the Owner, for the Owner's review and records, written warranties and related documents required by the Contract and assembled by the Contractor pursuant to Section 9.10; and issue a final Certificate for Payment pursuant to Section 9.10.

§ 4.2.10 If the Owner and Architect agree, the Architect will provide one or more project representatives to assist in carrying out the Architect's responsibilities at the site. The duties, responsibilities and limitations of authority of such project representatives shall be as set forth in an exhibit to be incorporated in the Contract Documents.

§ 4.2.11 The Architect will interpret and decide matters concerning performance under, and requirements of, the Contract Documents on written request of either the Owner or Contractor. The Architect's response to such requests will be made in writing within any time limits agreed upon or otherwise with reasonable promptness.

§ 4.2.12 Interpretations and decisions of the Architect will be consistent with the intent of, and reasonably inferable from, the Contract Documents and will be in writing or in the form of drawings. When making such interpretations and decisions, the Architect will endeavor to secure faithful performance by both Owner and Contractor, will not show partiality to either and will not be liable for results of interpretations or decisions rendered in good faith.

§ 4.2.13 The Architect's decisions on matters relating to aesthetic effect will be final if consistent with the intent expressed in the Contract Documents.

§ 4.2.14 The Architect will review and respond to requests for information about the Contract Documents. The Architect's response to such requests will be made in writing within any time limits agreed upon or otherwise with reasonable promptness. If appropriate, the Architect will prepare and issue supplemental Drawings and Specifications in response to the requests for information.

## ARTICLE 5 SUBCONTRACTORS

### § 5.1 DEFINITIONS

§ 5.1.1 A Subcontractor is a person or entity who has a direct contract with the Contractor to perform a portion of the Work at the site. The term "Subcontractor" is referred to throughout the Contract Documents as if singular in number and means a Subcontractor or an authorized representative of the Subcontractor. The term "Subcontractor" does not include a separate contractor or subcontractors of a separate contractor.

§ 5.1.2 A Sub-subcontractor is a person or entity who has a direct or indirect contract with a Subcontractor to perform a portion of the Work at the site. The term "Sub-subcontractor" is referred to throughout the Contract Documents as if singular in number and means a Sub-subcontractor or an authorized representative of the Sub-subcontractor.

## § 5.2 AWARD OF SUBCONTRACTS AND OTHER CONTRACTS FOR PORTIONS OF THE WORK

§ 5.2.1 Unless otherwise stated in the Contract Documents or the bidding requirements, the Contractor, as soon as practicable after award of the Contract, shall furnish in writing to the Owner through the Architect the names of persons or entities (including those who are to furnish materials or equipment fabricated to a special design) proposed for each principal portion of the Work. The Architect may reply within 14 days to the Contractor in writing stating (1) whether the Owner or the Architect has reasonable objection to any such proposed person or entity or (2) that the Architect requires additional time for review. Failure of the Owner or Architect to reply within the 14 day period shall constitute notice of no reasonable objection.

§ 5.2.2 The Contractor shall not contract with a proposed person or entity to whom the Owner or Architect has made reasonable and timely objection. The Contractor shall not be required to contract with anyone to whom the Contractor has made reasonable objection.

§ 5.2.3 If the Owner or Architect has reasonable objection to a person or entity proposed by the Contractor, the Contractor shall propose another to whom the Owner or Architect has no reasonable objection. If the proposed but rejected Subcontractor was reasonably capable of performing the Work, the Contract Sum and Contract Time shall be increased or decreased by the difference, if any, occasioned by such change, and an appropriate Change Order shall be issued before commencement of the substitute Subcontractor's Work. However, no increase in the Contract Sum or Contract Time shall be allowed for such change unless the Contractor has acted promptly and responsively in submitting names as required.

§ 5.2.4 The Contractor shall not substitute a Subcontractor, person or entity previously selected if the Owner or Architect makes reasonable objection to such substitution.

## § 5.3 SUBCONTRACTUAL RELATIONS

By appropriate agreement, written where legally required for validity, the Contractor shall require each Subcontractor, to the extent of the Work to be performed by the Subcontractor, to be bound to the Contractor by terms of the Contract Documents, and to assume toward the Contractor all the obligations and responsibilities, including the responsibility for safety of the Subcontractor's Work, which the Contractor, by these Documents, assumes toward the Owner and Architect. Each subcontract agreement shall preserve and protect the rights of the Owner and Architect under the Contract Documents with respect to the Work to be performed by the Subcontractor so that subcontracting thereof will not prejudice such rights, and shall allow to the Subcontractor, unless specifically provided otherwise in the subcontract agreement, the benefit of all rights, remedies and redress against the Contractor that the Contractor, by the Contract Documents, has against the Owner. Where appropriate, the Contractor shall require each Subcontractor to enter into similar agreements with Sub-subcontractors. The Contractor shall make available to each proposed Subcontractor, prior to the execution of the subcontract agreement, copies of the Contract Documents to which the Subcontractor will be bound, and, upon written request of the Subcontractor, identify to the Subcontractor terms and conditions of the proposed subcontract agreement that may be at variance with the Contract Documents. Subcontractors will similarly make copies of applicable portions of such documents available to their respective proposed Sub-subcontractors.

## § 5.4 CONTINGENT ASSIGNMENT OF SUBCONTRACTS

§ 5.4.1 Each subcontract agreement for a portion of the Work is assigned by the Contractor to the Owner, provided that

- .1 assignment is effective only after termination of the Contract by the Owner for cause pursuant to Section 14.2 and only for those subcontract agreements that the Owner accepts by notifying the Subcontractor and Contractor in writing; and
- .2 assignment is subject to the prior rights of the surety, if any, obligated under bond relating to the Contract.

When the Owner accepts the assignment of a subcontract agreement, the Owner assumes the Contractor's rights and obligations under the subcontract.

§ 5.4.2 Upon such assignment, if the Work has been suspended for more than 30 days, the Subcontractor's compensation shall be equitably adjusted for increases in cost resulting from the suspension.

§ 5.4.3 Upon such assignment to the Owner under this Section 5.4, the Owner may further assign the subcontract to a successor contractor or other entity. If the Owner assigns the subcontract to a successor contractor or other entity, the



Owner shall nevertheless remain legally responsible for all of the successor contractor's obligations under the subcontract.

## **ARTICLE 6 CONSTRUCTION BY OWNER OR BY SEPARATE CONTRACTORS**

### **§ 6.1 OWNER'S RIGHT TO PERFORM CONSTRUCTION AND TO AWARD SEPARATE CONTRACTS**

**§ 6.1.1** The Owner reserves the right to perform construction or operations related to the Project with the Owner's own forces, and to award separate contracts in connection with other portions of the Project or other construction or operations on the site under Conditions of the Contract identical or substantially similar to these including those portions related to insurance and waiver of subrogation. If the Contractor claims that delay or additional cost is involved because of such action by the Owner, the Contractor shall make such Claim as provided in Article 15.

**§ 6.1.2** When separate contracts are awarded for different portions of the Project or other construction or operations on the site, the term "Contractor" in the Contract Documents in each case shall mean the Contractor who executes each separate Owner-Contractor Agreement.

**§ 6.1.3** The Owner shall provide for coordination of the activities of the Owner's own forces and of each separate contractor with the Work of the Contractor, who shall cooperate with them. The Contractor shall participate with other separate contractors and the Owner in reviewing their construction schedules. The Contractor shall make any revisions to the construction schedule deemed necessary after a joint review and mutual agreement. The construction schedules shall then constitute the schedules to be used by the Contractor, separate contractors and the Owner until subsequently revised.

**§ 6.1.4** Unless otherwise provided in the Contract Documents, when the Owner performs construction or operations related to the Project with the Owner's own forces, the Owner shall be deemed to be subject to the same obligations and to have the same rights that apply to the Contractor under the Conditions of the Contract, including, without excluding others, those stated in Article 3, this Article 6 and Articles 10, 11 and 12.

### **§ 6.2 MUTUAL RESPONSIBILITY**

**§ 6.2.1** The Contractor shall afford the Owner and separate contractors reasonable opportunity for introduction and storage of their materials and equipment and performance of their activities, and shall connect and coordinate the Contractor's construction and operations with theirs as required by the Contract Documents.

**§ 6.2.2** If part of the Contractor's Work depends for proper execution or results upon construction or operations by the Owner or a separate contractor, the Contractor shall, prior to proceeding with that portion of the Work, promptly report to the Architect apparent discrepancies or defects in such other construction that would render it unsuitable for such proper execution and results. Failure of the Contractor so to report shall constitute an acknowledgment that the Owner's or separate contractor's completed or partially completed construction is fit and proper to receive the Contractor's Work, except as to defects not then reasonably discoverable.

**§ 6.2.3** The Contractor shall reimburse the Owner for costs the Owner incurs that are payable to a separate contractor because of the Contractor's delays, improperly timed activities or defective construction. The Owner shall be responsible to the Contractor for costs the Contractor incurs because of a separate contractor's delays, improperly timed activities, damage to the Work or defective construction.

**§ 6.2.4** The Contractor shall promptly remedy damage the Contractor wrongfully causes to completed or partially completed construction or to property of the Owner or separate contractors as provided in Section 10.2.5.

**§ 6.2.5** The Owner and each separate contractor shall have the same responsibilities for cutting and patching as are described for the Contractor in Section 3.14.

### **§ 6.3 OWNER'S RIGHT TO CLEAN UP**

If a dispute arises among the Contractor, separate contractors and the Owner as to the responsibility under their respective contracts for maintaining the premises and surrounding area free from waste materials and rubbish, the Owner may clean up and the Architect will allocate the cost among those responsible.

## **ARTICLE 7 CHANGES IN THE WORK**

### **§ 7.1 GENERAL**

**§ 7.1.1** Changes in the Work may be accomplished after execution of the Contract, and without invalidating the Contract, by Change Order, Construction Change Directive or order for a minor change in the Work, subject to the limitations stated in this Article 7 and elsewhere in the Contract Documents.

**§ 7.1.2** A Change Order shall be based upon agreement among the Owner, Contractor and Architect; a Construction Change Directive requires agreement by the Owner and Architect and may or may not be agreed to by the Contractor; an order for a minor change in the Work may be issued by the Architect alone.

**§ 7.1.3** Changes in the Work shall be performed under applicable provisions of the Contract Documents, and the Contractor shall proceed promptly, unless otherwise provided in the Change Order, Construction Change Directive or order for a minor change in the Work.

### **§ 7.2 CHANGE ORDERS**

**§ 7.2.1** A Change Order is a written instrument prepared by the Architect and signed by the Owner, Contractor and Architect stating their agreement upon all of the following:

- .1 The change in the Work;
- .2 The amount of the adjustment, if any, in the Contract Sum; and
- .3 The extent of the adjustment, if any, in the Contract Time.

### **§ 7.3 CONSTRUCTION CHANGE DIRECTIVES**

**§ 7.3.1** A Construction Change Directive is a written order prepared by the Architect and signed by the Owner and Architect, directing a change in the Work prior to agreement on adjustment, if any, in the Contract Sum or Contract Time, or both. The Owner may by Construction Change Directive, without invalidating the Contract, order changes in the Work within the general scope of the Contract consisting of additions, deletions or other revisions, the Contract Sum and Contract Time being adjusted accordingly.

**§ 7.3.2** A Construction Change Directive shall be used in the absence of total agreement on the terms of a Change Order.

**§ 7.3.3** If the Construction Change Directive provides for an adjustment to the Contract Sum, the adjustment shall be based on one of the following methods:

- .1 Mutual acceptance of a lump sum properly itemized and supported by sufficient substantiating data to permit evaluation;
- .2 Unit prices stated in the Contract Documents or subsequently agreed upon;
- .3 Cost to be determined in a manner agreed upon by the parties and a mutually acceptable fixed or percentage fee; or
- .4 As provided in Section 7.3.7.

**§ 7.3.4** If unit prices are stated in the Contract Documents or subsequently agreed upon, and if quantities originally contemplated are materially changed in a proposed Change Order or Construction Change Directive so that application of such unit prices to quantities of Work proposed will cause substantial inequity to the Owner or Contractor, the applicable unit prices shall be equitably adjusted.

**§ 7.3.5** Upon receipt of a Construction Change Directive, the Contractor shall promptly proceed with the change in the Work involved and advise the Architect of the Contractor's agreement or disagreement with the method, if any, provided in the Construction Change Directive for determining the proposed adjustment in the Contract Sum or Contract Time.

**§ 7.3.6** A Construction Change Directive signed by the Contractor indicates the Contractor's agreement therewith, including adjustment in Contract Sum and Contract Time or the method for determining them. Such agreement shall be effective immediately and shall be recorded as a Change Order.

**§ 7.3.7** If the Contractor does not respond promptly or disagrees with the method for adjustment in the Contract Sum, the Architect shall determine the method and the adjustment on the basis of reasonable expenditures and savings of those performing the Work attributable to the change, including, in case of an increase in the Contract Sum, an amount

Init.

for overhead and profit as set forth in the Agreement, or if no such amount is set forth in the Agreement, a reasonable amount. In such case, and also under Section 7.3.3.3, the Contractor shall keep and present, in such form as the Architect may prescribe, an itemized accounting together with appropriate supporting data. Unless otherwise provided in the Contract Documents, costs for the purposes of this Section 7.3.7 shall be limited to the following:

- .1 Costs of labor, including social security, old age and unemployment insurance, fringe benefits required by agreement or custom, and workers' compensation insurance;
- .2 Costs of materials, supplies and equipment, including cost of transportation, whether incorporated or consumed;
- .3 Rental costs of machinery and equipment, exclusive of hand tools, whether rented from the Contractor or others;
- .4 Costs of premiums for all bonds and insurance, permit fees, and sales, use or similar taxes related to the Work; and
- .5 Additional costs of supervision and field office personnel directly attributable to the change.

§ 7.3.8 The amount of credit to be allowed by the Contractor to the Owner for a deletion or change that results in a net decrease in the Contract Sum shall be actual net cost as confirmed by the Architect. When both additions and credits covering related Work or substitutions are involved in a change, the allowance for overhead and profit shall be figured on the basis of net increase, if any, with respect to that change.

§ 7.3.9 Pending final determination of the total cost of a Construction Change Directive to the Owner, the Contractor may request payment for Work completed under the Construction Change Directive in Applications for Payment. The Architect will make an interim determination for purposes of monthly certification for payment for those costs and certify for payment the amount that the Architect determines, in the Architect's professional judgment, to be reasonably justified. The Architect's interim determination of cost shall adjust the Contract Sum on the same basis as a Change Order, subject to the right of either party to disagree and assert a Claim in accordance with Article 15.

§ 7.3.10 When the Owner and Contractor agree with a determination made by the Architect concerning the adjustments in the Contract Sum and Contract Time, or otherwise reach agreement upon the adjustments, such agreement shall be effective immediately and the Architect will prepare a Change Order. Change Orders may be issued for all or any part of a Construction Change Directive.

#### § 7.4 MINOR CHANGES IN THE WORK

The Architect has authority to order minor changes in the Work not involving adjustment in the Contract Sum or extension of the Contract Time and not inconsistent with the intent of the Contract Documents. Such changes will be effected by written order signed by the Architect and shall be binding on the Owner and Contractor.

### ARTICLE 8 TIME

#### § 8.1 DEFINITIONS

§ 8.1.1 Unless otherwise provided, Contract Time is the period of time, including authorized adjustments, allotted in the Contract Documents for Substantial Completion of the Work.

§ 8.1.2 The date of commencement of the Work is the date established in the Agreement.

§ 8.1.3 The date of Substantial Completion is the date certified by the Architect in accordance with Section 9.8.

§ 8.1.4 The term "day" as used in the Contract Documents shall mean calendar day unless otherwise specifically defined.

#### § 8.2 PROGRESS AND COMPLETION

§ 8.2.1 Time limits stated in the Contract Documents are of the essence of the Contract. By executing the Agreement the Contractor confirms that the Contract Time is a reasonable period for performing the Work.

§ 8.2.2 The Contractor shall not knowingly, except by agreement or instruction of the Owner in writing, prematurely commence operations on the site or elsewhere prior to the effective date of insurance required by Article 11 to be furnished by the Contractor and Owner. The date of commencement of the Work shall not be changed by the effective date of such insurance.

§ 8.2.3 The Contractor shall proceed expeditiously with adequate forces and shall achieve Substantial Completion within the Contract Time.

### § 8.3 DELAYS AND EXTENSIONS OF TIME

§ 8.3.1 If the Contractor is delayed at any time in the commencement or progress of the Work by an act or neglect of the Owner or Architect, or of an employee of either, or of a separate contractor employed by the Owner; or by changes ordered in the Work; or by labor disputes, fire, unusual delay in deliveries, unavoidable casualties or other causes beyond the Contractor's control; or by delay authorized by the Owner pending mediation and arbitration; or by other causes that the Architect determines may justify delay, then the Contract Time shall be extended by Change Order for such reasonable time as the Architect may determine.

§ 8.3.2 Claims relating to time shall be made in accordance with applicable provisions of Article 15.

§ 8.3.3 This Section 8.3 does not preclude recovery of damages for delay by either party under other provisions of the Contract Documents.

## ARTICLE 9 PAYMENTS AND COMPLETION

### § 9.1 CONTRACT SUM

The Contract Sum is stated in the Agreement and, including authorized adjustments, is the total amount payable by the Owner to the Contractor for performance of the Work under the Contract Documents.

### § 9.2 SCHEDULE OF VALUES

Where the Contract is based on a stipulated sum or Guaranteed Maximum Price, the Contractor shall submit to the Architect, before the first Application for Payment, a schedule of values allocating the entire Contract Sum to the various portions of the Work and prepared in such form and supported by such data to substantiate its accuracy as the Architect may require. This schedule, unless objected to by the Architect, shall be used as a basis for reviewing the Contractor's Applications for Payment.

### § 9.3 APPLICATIONS FOR PAYMENT

§ 9.3.1 At least ten days before the date established for each progress payment, the Contractor shall submit to the Architect an itemized Application for Payment prepared in accordance with the schedule of values, if required under Section 9.2., for completed portions of the Work. Such application shall be notarized, if required, and supported by such data substantiating the Contractor's right to payment as the Owner or Architect may require, such as copies of requisitions from Subcontractors and material suppliers, and shall reflect retainage if provided for in the Contract Documents.

§ 9.3.1.1 As provided in Section 7.3.9, such applications may include requests for payment on account of changes in the Work that have been properly authorized by Construction Change Directives, or by interim determinations of the Architect, but not yet included in Change Orders.

§ 9.3.1.2 Applications for Payment shall not include requests for payment for portions of the Work for which the Contractor does not intend to pay a Subcontractor or material supplier, unless such Work has been performed by others whom the Contractor intends to pay.

§ 9.3.2 Unless otherwise provided in the Contract Documents, payments shall be made on account of materials and equipment delivered and suitably stored at the site for subsequent incorporation in the Work. If approved in advance by the Owner, payment may similarly be made for materials and equipment suitably stored off the site at a location agreed upon in writing. Payment for materials and equipment stored on or off the site shall be conditioned upon compliance by the Contractor with procedures satisfactory to the Owner to establish the Owner's title to such materials and equipment or otherwise protect the Owner's interest, and shall include the costs of applicable insurance, storage and transportation to the site for such materials and equipment stored off the site.

§ 9.3.3 The Contractor warrants that title to all Work covered by an Application for Payment will pass to the Owner no later than the time of payment. The Contractor further warrants that upon submittal of an Application for Payment all Work for which Certificates for Payment have been previously issued and payments received from the Owner shall, to the best of the Contractor's knowledge, information and belief, be free and clear of liens, claims, security interests or

Init.

encumbrances in favor of the Contractor, Subcontractors, material suppliers, or other persons or entities making a claim by reason of having provided labor, materials and equipment relating to the Work.

#### **§ 9.4 CERTIFICATES FOR PAYMENT**

**§ 9.4.1** The Architect will, within seven days after receipt of the Contractor's Application for Payment, either issue to the Owner a Certificate for Payment, with a copy to the Contractor, for such amount as the Architect determines is properly due, or notify the Contractor and Owner in writing of the Architect's reasons for withholding certification in whole or in part as provided in Section 9.5.1.

**§ 9.4.2** The issuance of a Certificate for Payment will constitute a representation by the Architect to the Owner, based on the Architect's evaluation of the Work and the data comprising the Application for Payment, that, to the best of the Architect's knowledge, information and belief, the Work has progressed to the point indicated and that the quality of the Work is in accordance with the Contract Documents. The foregoing representations are subject to an evaluation of the Work for conformance with the Contract Documents upon Substantial Completion, to results of subsequent tests and inspections, to correction of minor deviations from the Contract Documents prior to completion and to specific qualifications expressed by the Architect. The issuance of a Certificate for Payment will further constitute a representation that the Contractor is entitled to payment in the amount certified. However, the issuance of a Certificate for Payment will not be a representation that the Architect has (1) made exhaustive or continuous on-site inspections to check the quality or quantity of the Work, (2) reviewed construction means, methods, techniques, sequences or procedures, (3) reviewed copies of requisitions received from Subcontractors and material suppliers and other data requested by the Owner to substantiate the Contractor's right to payment, or (4) made examination to ascertain how or for what purpose the Contractor has used money previously paid on account of the Contract Sum.

#### **§ 9.5 DECISIONS TO WITHHOLD CERTIFICATION**

**§ 9.5.1** The Architect may withhold a Certificate for Payment in whole or in part, to the extent reasonably necessary to protect the Owner, if in the Architect's opinion the representations to the Owner required by Section 9.4.2 cannot be made. If the Architect is unable to certify payment in the amount of the Application, the Architect will notify the Contractor and Owner as provided in Section 9.4.1. If the Contractor and Architect cannot agree on a revised amount, the Architect will promptly issue a Certificate for Payment for the amount for which the Architect is able to make such representations to the Owner. The Architect may also withhold a Certificate for Payment or, because of subsequently discovered evidence, may nullify the whole or a part of a Certificate for Payment previously issued, to such extent as may be necessary in the Architect's opinion to protect the Owner from loss for which the Contractor is responsible, including loss resulting from acts and omissions described in Section 3.3.2, because of

- .1 defective Work not remedied;
- .2 third party claims filed or reasonable evidence indicating probable filing of such claims unless security acceptable to the Owner is provided by the Contractor;
- .3 failure of the Contractor to make payments properly to Subcontractors or for labor, materials or equipment;
- .4 reasonable evidence that the Work cannot be completed for the unpaid balance of the Contract Sum;
- .5 damage to the Owner or a separate contractor;
- .6 reasonable evidence that the Work will not be completed within the Contract Time, and that the unpaid balance would not be adequate to cover actual or liquidated damages for the anticipated delay; or
- .7 repeated failure to carry out the Work in accordance with the Contract Documents.

**§ 9.5.2** When the above reasons for withholding certification are removed, certification will be made for amounts previously withheld.

**§ 9.5.3** If the Architect withholds certification for payment under Section 9.5.1.3, the Owner may, at its sole option, issue joint checks to the Contractor and to any Subcontractor or material or equipment suppliers to whom the Contractor failed to make payment for Work properly performed or material or equipment suitably delivered. If the Owner makes payments by joint check, the Owner shall notify the Architect and the Architect will reflect such payment on the next Certificate for Payment.

#### **§ 9.6 PROGRESS PAYMENTS**

**§ 9.6.1** After the Architect has issued a Certificate for Payment, the Owner shall make payment in the manner and within the time provided in the Contract Documents, and shall so notify the Architect.

Init.

§ 9.6.2 The Contractor shall pay each Subcontractor no later than seven days after receipt of payment from the Owner the amount to which the Subcontractor is entitled, reflecting percentages actually retained from payments to the Contractor on account of the Subcontractor's portion of the Work. The Contractor shall, by appropriate agreement with each Subcontractor, require each Subcontractor to make payments to Sub-subcontractors in a similar manner.

§ 9.6.3 The Architect will, on request, furnish to a Subcontractor, if practicable, information regarding percentages of completion or amounts applied for by the Contractor and action taken thereon by the Architect and Owner on account of portions of the Work done by such Subcontractor.

§ 9.6.4 The Owner has the right to request written evidence from the Contractor that the Contractor has properly paid Subcontractors and material and equipment suppliers amounts paid by the Owner to the Contractor for subcontracted Work. If the Contractor fails to furnish such evidence within seven days, the Owner shall have the right to contact Subcontractors to ascertain whether they have been properly paid. Neither the Owner nor Architect shall have an obligation to pay or to see to the payment of money to a Subcontractor, except as may otherwise be required by law.

§ 9.6.5 Contractor payments to material and equipment suppliers shall be treated in a manner similar to that provided in Sections 9.6.2, 9.6.3 and 9.6.4.

§ 9.6.6 A Certificate for Payment, a progress payment, or partial or entire use or occupancy of the Project by the Owner shall not constitute acceptance of Work not in accordance with the Contract Documents.

§ 9.6.7 Unless the Contractor provides the Owner with a payment bond in the full penal sum of the Contract Sum, payments received by the Contractor for Work properly performed by Subcontractors and suppliers shall be held by the Contractor for those Subcontractors or suppliers who performed Work or furnished materials, or both, under contract with the Contractor for which payment was made by the Owner. Nothing contained herein shall require money to be placed in a separate account and not commingled with money of the Contractor, shall create any fiduciary liability or tort liability on the part of the Contractor for breach of trust or shall entitle any person or entity to an award of punitive damages against the Contractor for breach of the requirements of this provision.

#### § 9.7 FAILURE OF PAYMENT

If the Architect does not issue a Certificate for Payment, through no fault of the Contractor, within seven days after receipt of the Contractor's Application for Payment, or if the Owner does not pay the Contractor within seven days after the date established in the Contract Documents the amount certified by the Architect or awarded by binding dispute resolution, then the Contractor may, upon seven additional days' written notice to the Owner and Architect, stop the Work until payment of the amount owing has been received. The Contract Time shall be extended appropriately and the Contract Sum shall be increased by the amount of the Contractor's reasonable costs of shut-down, delay and start-up, plus interest as provided for in the Contract Documents.

#### § 9.8 SUBSTANTIAL COMPLETION

§ 9.8.1 Substantial Completion is the stage in the progress of the Work when the Work or designated portion thereof is sufficiently complete in accordance with the Contract Documents so that the Owner can occupy or utilize the Work for its intended use.

§ 9.8.2 When the Contractor considers that the Work, or a portion thereof which the Owner agrees to accept separately, is substantially complete, the Contractor shall prepare and submit to the Architect a comprehensive list of items to be completed or corrected prior to final payment. Failure to include an item on such list does not alter the responsibility of the Contractor to complete all Work in accordance with the Contract Documents.

§ 9.8.3 Upon receipt of the Contractor's list, the Architect will make an inspection to determine whether the Work or designated portion thereof is substantially complete. If the Architect's inspection discloses any item, whether or not included on the Contractor's list, which is not sufficiently complete in accordance with the Contract Documents so that the Owner can occupy or utilize the Work or designated portion thereof for its intended use, the Contractor shall, before issuance of the Certificate of Substantial Completion, complete or correct such item upon notification by the Architect. In such case, the Contractor shall then submit a request for another inspection by the Architect to determine Substantial Completion.

Init.

§ 9.8.4 When the Work or designated portion thereof is substantially complete, the Architect will prepare a Certificate of Substantial Completion that shall establish the date of Substantial Completion, shall establish responsibilities of the Owner and Contractor for security, maintenance, heat, utilities, damage to the Work and insurance, and shall fix the time within which the Contractor shall finish all items on the list accompanying the Certificate. Warranties required by the Contract Documents shall commence on the date of Substantial Completion of the Work or designated portion thereof unless otherwise provided in the Certificate of Substantial Completion.

§ 9.8.5 The Certificate of Substantial Completion shall be submitted to the Owner and Contractor for their written acceptance of responsibilities assigned to them in such Certificate. Upon such acceptance and consent of surety, if any, the Owner shall make payment of retainage applying to such Work or designated portion thereof. Such payment shall be adjusted for Work that is incomplete or not in accordance with the requirements of the Contract Documents.

#### § 9.9 PARTIAL OCCUPANCY OR USE

§ 9.9.1 The Owner may occupy or use any completed or partially completed portion of the Work at any stage when such portion is designated by separate agreement with the Contractor, provided such occupancy or use is consented to by the insurer as required under Section 11.3.1.5 and authorized by public authorities having jurisdiction over the Project. Such partial occupancy or use may commence whether or not the portion is substantially complete, provided the Owner and Contractor have accepted in writing the responsibilities assigned to each of them for payments, retainage, if any, security, maintenance, heat, utilities, damage to the Work and insurance, and have agreed in writing concerning the period for correction of the Work and commencement of warranties required by the Contract Documents. When the Contractor considers a portion substantially complete, the Contractor shall prepare and submit a list to the Architect as provided under Section 9.8.2. Consent of the Contractor to partial occupancy or use shall not be unreasonably withheld. The stage of the progress of the Work shall be determined by written agreement between the Owner and Contractor or, if no agreement is reached, by decision of the Architect.

§ 9.9.2 Immediately prior to such partial occupancy or use, the Owner, Contractor and Architect shall jointly inspect the area to be occupied or portion of the Work to be used in order to determine and record the condition of the Work.

§ 9.9.3 Unless otherwise agreed upon, partial occupancy or use of a portion or portions of the Work shall not constitute acceptance of Work not complying with the requirements of the Contract Documents.

#### § 9.10 FINAL COMPLETION AND FINAL PAYMENT

§ 9.10.1 Upon receipt of the Contractor's written notice that the Work is ready for final inspection and acceptance and upon receipt of a final Application for Payment, the Architect will promptly make such inspection and, when the Architect finds the Work acceptable under the Contract Documents and the Contract fully performed, the Architect will promptly issue a final Certificate for Payment stating that to the best of the Architect's knowledge, information and belief, and on the basis of the Architect's on-site visits and inspections, the Work has been completed in accordance with terms and conditions of the Contract Documents and that the entire balance found to be due the Contractor and noted in the final Certificate is due and payable. The Architect's final Certificate for Payment will constitute a further representation that conditions listed in Section 9.10.2 as precedent to the Contractor's being entitled to final payment have been fulfilled.

§ 9.10.2 Neither final payment nor any remaining retained percentage shall become due until the Contractor submits to the Architect (1) an affidavit that payrolls, bills for materials and equipment, and other indebtedness connected with the Work for which the Owner or the Owner's property might be responsible or encumbered (less amounts withheld by Owner) have been paid or otherwise satisfied, (2) a certificate evidencing that insurance required by the Contract Documents to remain in force after final payment is currently in effect and will not be canceled or allowed to expire until at least 30 days' prior written notice has been given to the Owner, (3) a written statement that the Contractor knows of no substantial reason that the insurance will not be renewable to cover the period required by the Contract Documents, (4) consent of surety, if any, to final payment and (5), if required by the Owner, other data establishing payment or satisfaction of obligations, such as receipts, releases and waivers of liens, claims, security interests or encumbrances arising out of the Contract, to the extent and in such form as may be designated by the Owner. If a Subcontractor refuses to furnish a release or waiver required by the Owner, the Contractor may furnish a bond satisfactory to the Owner to indemnify the Owner against such lien. If such lien remains unsatisfied after payments are made, the Contractor shall refund to the Owner all money that the Owner may be compelled to pay in discharging such lien, including all costs and reasonable attorneys' fees.

§ 9.10.3 If, after Substantial Completion of the Work, final completion thereof is materially delayed through no fault of the Contractor or by issuance of Change Orders affecting final completion, and the Architect so confirms, the Owner shall, upon application by the Contractor and certification by the Architect, and without terminating the Contract, make payment of the balance due for that portion of the Work fully completed and accepted. If the remaining balance for Work not fully completed or corrected is less than retainage stipulated in the Contract Documents, and if bonds have been furnished, the written consent of surety to payment of the balance due for that portion of the Work fully completed and accepted shall be submitted by the Contractor to the Architect prior to certification of such payment. Such payment shall be made under terms and conditions governing final payment, except that it shall not constitute a waiver of claims.

§ 9.10.4 The making of final payment shall constitute a waiver of Claims by the Owner except those arising from

- .1 liens, Claims, security interests or encumbrances arising out of the Contract and unsettled;
- .2 failure of the Work to comply with the requirements of the Contract Documents; or
- .3 terms of special warranties required by the Contract Documents.

§ 9.10.5 Acceptance of final payment by the Contractor, a Subcontractor or material supplier shall constitute a waiver of claims by that payee except those previously made in writing and identified by that payee as unsettled at the time of final Application for Payment.

## ARTICLE 10 PROTECTION OF PERSONS AND PROPERTY

### § 10.1 SAFETY PRECAUTIONS AND PROGRAMS

The Contractor shall be responsible for initiating, maintaining and supervising all safety precautions and programs in connection with the performance of the Contract.

### § 10.2 SAFETY OF PERSONS AND PROPERTY

§ 10.2.1 The Contractor shall take reasonable precautions for safety of, and shall provide reasonable protection to prevent damage, injury or loss to

- .1 employees on the Work and other persons who may be affected thereby;
- .2 the Work and materials and equipment to be incorporated therein, whether in storage on or off the site, under care, custody or control of the Contractor or the Contractor's Subcontractors or Sub-subcontractors; and
- .3 other property at the site or adjacent thereto, such as trees, shrubs, lawns, walks, pavements, roadways, structures and utilities not designated for removal, relocation or replacement in the course of construction.

§ 10.2.2 The Contractor shall comply with and give notices required by applicable laws, statutes, ordinances, codes, rules and regulations, and lawful orders of public authorities bearing on safety of persons or property or their protection from damage, injury or loss.

§ 10.2.3 The Contractor shall erect and maintain, as required by existing conditions and performance of the Contract, reasonable safeguards for safety and protection, including posting danger signs and other warnings against hazards, promulgating safety regulations and notifying owners and users of adjacent sites and utilities.

§ 10.2.4 When use or storage of explosives or other hazardous materials or equipment or unusual methods are necessary for execution of the Work, the Contractor shall exercise utmost care and carry on such activities under supervision of properly qualified personnel.

§ 10.2.5 The Contractor shall promptly remedy damage and loss (other than damage or loss insured under property insurance required by the Contract Documents) to property referred to in Sections 10.2.1.2 and 10.2.1.3 caused in whole or in part by the Contractor, a Subcontractor, a Sub-subcontractor, or anyone directly or indirectly employed by any of them, or by anyone for whose acts they may be liable and for which the Contractor is responsible under Sections 10.2.1.2 and 10.2.1.3, except damage or loss attributable to acts or omissions of the Owner or Architect or anyone directly or indirectly employed by either of them, or by anyone for whose acts either of them may be liable, and not attributable to the fault or negligence of the Contractor. The foregoing obligations of the Contractor are in addition to the Contractor's obligations under Section 3.18.



§ 10.2.6 The Contractor shall designate a responsible member of the Contractor's organization at the site whose duty shall be the prevention of accidents. This person shall be the Contractor's superintendent unless otherwise designated by the Contractor in writing to the Owner and Architect.

§ 10.2.7 The Contractor shall not permit any part of the construction or site to be loaded so as to cause damage or create an unsafe condition.

**§ 10.2.8 INJURY OR DAMAGE TO PERSON OR PROPERTY**

If either party suffers injury or damage to person or property because of an act or omission of the other party, or of others for whose acts such party is legally responsible, written notice of such injury or damage, whether or not insured, shall be given to the other party within a reasonable time not exceeding 21 days after discovery. The notice shall provide sufficient detail to enable the other party to investigate the matter.

**§ 10.3 HAZARDOUS MATERIALS**

§ 10.3.1 The Contractor is responsible for compliance with any requirements included in the Contract Documents regarding hazardous materials. If the Contractor encounters a hazardous material or substance not addressed in the Contract Documents and if reasonable precautions will be inadequate to prevent foreseeable bodily injury or death to persons resulting from a material or substance, including but not limited to asbestos or polychlorinated biphenyl (PCB), encountered on the site by the Contractor, the Contractor shall, upon recognizing the condition, immediately stop Work in the affected area and report the condition to the Owner and Architect in writing.

§ 10.3.2 Upon receipt of the Contractor's written notice, the Owner shall obtain the services of a licensed laboratory to verify the presence or absence of the material or substance reported by the Contractor and, in the event such material or substance is found to be present, to cause it to be rendered harmless. Unless otherwise required by the Contract Documents, the Owner shall furnish in writing to the Contractor and Architect the names and qualifications of persons or entities who are to perform tests verifying the presence or absence of such material or substance or who are to perform the task of removal or safe containment of such material or substance. The Contractor and the Architect will promptly reply to the Owner in writing stating whether or not either has reasonable objection to the persons or entities proposed by the Owner. If either the Contractor or Architect has an objection to a person or entity proposed by the Owner, the Owner shall propose another to whom the Contractor and the Architect have no reasonable objection. When the material or substance has been rendered harmless, Work in the affected area shall resume upon written agreement of the Owner and Contractor. By Change Order, the Contract Time shall be extended appropriately and the Contract Sum shall be increased in the amount of the Contractor's reasonable additional costs of shut-down, delay and start-up.

§ 10.3.3 To the fullest extent permitted by law, the Owner shall indemnify and hold harmless the Contractor, Subcontractors, Architect, Architect's consultants and agents and employees of any of them from and against claims, damages, losses and expenses, including but not limited to attorneys' fees, arising out of or resulting from performance of the Work in the affected area if in fact the material or substance presents the risk of bodily injury or death as described in Section 10.3.1 and has not been rendered harmless, provided that such claim, damage, loss or expense is attributable to bodily injury, sickness, disease or death, or to injury to or destruction of tangible property (other than the Work itself), except to the extent that such damage, loss or expense is due to the fault or negligence of the party seeking indemnity.

§ 10.3.4 The Owner shall not be responsible under this Section 10.3 for materials or substances the Contractor brings to the site unless such materials or substances are required by the Contract Documents. The Owner shall be responsible for materials or substances required by the Contract Documents, except to the extent of the Contractor's fault or negligence in the use and handling of such materials or substances.

§ 10.3.5 The Contractor shall indemnify the Owner for the cost and expense the Owner incurs (1) for remediation of a material or substance the Contractor brings to the site and negligently handles, or (2) where the Contractor fails to perform its obligations under Section 10.3.1, except to the extent that the cost and expense are due to the Owner's fault or negligence.

§ 10.3.6 If, without negligence on the part of the Contractor, the Contractor is held liable by a government agency for the cost of remediation of a hazardous material or substance solely by reason of performing Work as required by the Contract Documents, the Owner shall indemnify the Contractor for all cost and expense thereby incurred.

Init.

## § 10.4 EMERGENCIES

In an emergency affecting safety of persons or property, the Contractor shall act, at the Contractor's discretion, to prevent threatened damage, injury or loss. Additional compensation or extension of time claimed by the Contractor on account of an emergency shall be determined as provided in Article 15 and Article 7.

## ARTICLE 11 INSURANCE AND BONDS

### § 11.1 CONTRACTOR'S LIABILITY INSURANCE

§ 11.1.1 The Contractor shall purchase from and maintain in a company or companies lawfully authorized to do business in the jurisdiction in which the Project is located such insurance as will protect the Contractor from claims set forth below which may arise out of or result from the Contractor's operations and completed operations under the Contract and for which the Contractor may be legally liable, whether such operations be by the Contractor or by a Subcontractor or by anyone directly or indirectly employed by any of them, or by anyone for whose acts any of them may be liable:

- .1 Claims under workers' compensation, disability benefit and other similar employee benefit acts that are applicable to the Work to be performed;
- .2 Claims for damages because of bodily injury, occupational sickness or disease, or death of the Contractor's employees;
- .3 Claims for damages because of bodily injury, sickness or disease, or death of any person other than the Contractor's employees;
- .4 Claims for damages insured by usual personal injury liability coverage;
- .5 Claims for damages, other than to the Work itself, because of injury to or destruction of tangible property, including loss of use resulting therefrom;
- .6 Claims for damages because of bodily injury, death of a person or property damage arising out of ownership, maintenance or use of a motor vehicle;
- .7 Claims for bodily injury or property damage arising out of completed operations; and
- .8 Claims involving contractual liability insurance applicable to the Contractor's obligations under Section 3.18.

§ 11.1.2 The insurance required by Section 11.1.1 shall be written for not less than limits of liability specified in the Contract Documents or required by law, whichever coverage is greater. Coverages, whether written on an occurrence or claims-made basis, shall be maintained without interruption from the date of commencement of the Work until the date of final payment and termination of any coverage required to be maintained after final payment, and, with respect to the Contractor's completed operations coverage, until the expiration of the period for correction of Work or for such other period for maintenance of completed operations coverage as specified in the Contract Documents.

§ 11.1.3 Certificates of insurance acceptable to the Owner shall be filed with the Owner prior to commencement of the Work and thereafter upon renewal or replacement of each required policy of insurance. These certificates and the insurance policies required by this Section 11.1 shall contain a provision that coverages afforded under the policies will not be canceled or allowed to expire until at least 30 days' prior written notice has been given to the Owner. An additional certificate evidencing continuation of liability coverage, including coverage for completed operations, shall be submitted with the final Application for Payment as required by Section 9.10.2 and thereafter upon renewal or replacement of such coverage until the expiration of the time required by Section 11.1.2. Information concerning reduction of coverage on account of revised limits or claims paid under the General Aggregate, or both, shall be furnished by the Contractor with reasonable promptness.

§ 11.1.4 The Contractor shall cause the commercial liability coverage required by the Contract Documents to include (1) the Owner, the Architect and the Architect's Consultants as additional insureds for claims caused in whole or in part by the Contractor's negligent acts or omissions during the Contractor's operations; and (2) the Owner as an additional insured for claims caused in whole or in part by the Contractor's negligent acts or omissions during the Contractor's completed operations.

### § 11.2 OWNER'S LIABILITY INSURANCE

The Owner shall be responsible for purchasing and maintaining the Owner's usual liability insurance.

Init.

### **§ 11.3 PROPERTY INSURANCE**

**§ 11.3.1** Unless otherwise provided, the Owner shall purchase and maintain, in a company or companies lawfully authorized to do business in the jurisdiction in which the Project is located, property insurance written on a builder's risk "all-risk" or equivalent policy form in the amount of the initial Contract Sum, plus value of subsequent Contract Modifications and cost of materials supplied or installed by others, comprising total value for the entire Project at the site on a replacement cost basis without optional deductibles. Such property insurance shall be maintained, unless otherwise provided in the Contract Documents or otherwise agreed in writing by all persons and entities who are beneficiaries of such insurance, until final payment has been made as provided in Section 9.10 or until no person or entity other than the Owner has an insurable interest in the property required by this Section 11.3 to be covered, whichever is later. This insurance shall include interests of the Owner, the Contractor, Subcontractors and Sub-subcontractors in the Project.

**§ 11.3.1.1** Property insurance shall be on an "all-risk" or equivalent policy form and shall include, without limitation, insurance against the perils of fire (with extended coverage) and physical loss or damage including, without duplication of coverage, theft, vandalism, malicious mischief, collapse, earthquake, flood, windstorm, falsework, testing and startup, temporary buildings and debris removal including demolition occasioned by enforcement of any applicable legal requirements, and shall cover reasonable compensation for Architect's and Contractor's services and expenses required as a result of such insured loss.

**§ 11.3.1.2** If the Owner does not intend to purchase such property insurance required by the Contract and with all of the coverages in the amount described above, the Owner shall so inform the Contractor in writing prior to commencement of the Work. The Contractor may then effect insurance that will protect the interests of the Contractor, Subcontractors and Sub-subcontractors in the Work, and by appropriate Change Order the cost thereof shall be charged to the Owner. If the Contractor is damaged by the failure or neglect of the Owner to purchase or maintain insurance as described above, without so notifying the Contractor in writing, then the Owner shall bear all reasonable costs properly attributable thereto.

**§ 11.3.1.3** If the property insurance requires deductibles, the Owner shall pay costs not covered because of such deductibles.

**§ 11.3.1.4** This property insurance shall cover portions of the Work stored off the site, and also portions of the Work in transit.

**§ 11.3.1.5** Partial occupancy or use in accordance with Section 9.9 shall not commence until the insurance company or companies providing property insurance have consented to such partial occupancy or use by endorsement or otherwise. The Owner and the Contractor shall take reasonable steps to obtain consent of the insurance company or companies and shall, without mutual written consent, take no action with respect to partial occupancy or use that would cause cancellation, lapse or reduction of insurance.

### **§ 11.3.2 BOILER AND MACHINERY INSURANCE**

The Owner shall purchase and maintain boiler and machinery insurance required by the Contract Documents or by law, which shall specifically cover such insured objects during installation and until final acceptance by the Owner; this insurance shall include interests of the Owner, Contractor, Subcontractors and Sub-subcontractors in the Work, and the Owner and Contractor shall be named insureds.

### **§ 11.3.3 LOSS OF USE INSURANCE**

The Owner, at the Owner's option, may purchase and maintain such insurance as will insure the Owner against loss of use of the Owner's property due to fire or other hazards, however caused. The Owner waives all rights of action against the Contractor for loss of use of the Owner's property, including consequential losses due to fire or other hazards however caused.

**§ 11.3.4** If the Contractor requests in writing that insurance for risks other than those described herein or other special causes of loss be included in the property insurance policy, the Owner shall, if possible, include such insurance, and the cost thereof shall be charged to the Contractor by appropriate Change Order.

**§ 11.3.5** If during the Project construction period the Owner insures properties, real or personal or both, at or adjacent to the site by property insurance under policies separate from those insuring the Project, or if after final payment

property insurance is to be provided on the completed Project through a policy or policies other than those insuring the Project during the construction period, the Owner shall waive all rights in accordance with the terms of Section 11.3.7 for damages caused by fire or other causes of loss covered by this separate property insurance. All separate policies shall provide this waiver of subrogation by endorsement or otherwise.

§ 11.3.6 Before an exposure to loss may occur, the Owner shall file with the Contractor a copy of each policy that includes insurance coverages required by this Section 11.3. Each policy shall contain all generally applicable conditions, definitions, exclusions and endorsements related to this Project. Each policy shall contain a provision that the policy will not be canceled or allowed to expire, and that its limits will not be reduced, until at least 30 days' prior written notice has been given to the Contractor.

#### § 11.3.7 WAIVERS OF SUBROGATION

The Owner and Contractor waive all rights against (1) each other and any of their subcontractors, sub-subcontractors, agents and employees, each of the other, and (2) the Architect, Architect's consultants, separate contractors described in Article 6, if any, and any of their subcontractors, sub-subcontractors, agents and employees, for damages caused by fire or other causes of loss to the extent covered by property insurance obtained pursuant to this Section 11.3 or other property insurance applicable to the Work, except such rights as they have to proceeds of such insurance held by the Owner as fiduciary. The Owner or Contractor, as appropriate, shall require of the Architect, Architect's consultants, separate contractors described in Article 6, if any, and the subcontractors, sub-subcontractors, agents and employees of any of them, by appropriate agreements, written where legally required for validity, similar waivers each in favor of other parties enumerated herein. The policies shall provide such waivers of subrogation by endorsement or otherwise. A waiver of subrogation shall be effective as to a person or entity even though that person or entity would otherwise have a duty of indemnification, contractual or otherwise, did not pay the insurance premium directly or indirectly, and whether or not the person or entity had an insurable interest in the property damaged.

§ 11.3.8 A loss insured under the Owner's property insurance shall be adjusted by the Owner as fiduciary and made payable to the Owner as fiduciary for the insureds, as their interests may appear, subject to requirements of any applicable mortgagee clause and of Section 11.3.10. The Contractor shall pay Subcontractors their just shares of insurance proceeds received by the Contractor, and by appropriate agreements, written where legally required for validity, shall require Subcontractors to make payments to their Sub-subcontractors in similar manner.

§ 11.3.9 If required in writing by a party in interest, the Owner as fiduciary shall, upon occurrence of an insured loss, give bond for proper performance of the Owner's duties. The cost of required bonds shall be charged against proceeds received as fiduciary. The Owner shall deposit in a separate account proceeds so received, which the Owner shall distribute in accordance with such agreement as the parties in interest may reach, or as determined in accordance with the method of binding dispute resolution selected in the Agreement between the Owner and Contractor. If after such loss no other special agreement is made and unless the Owner terminates the Contract for convenience, replacement of damaged property shall be performed by the Contractor after notification of a Change in the Work in accordance with Article 7.

§ 11.3.10 The Owner as fiduciary shall have power to adjust and settle a loss with insurers unless one of the parties in interest shall object in writing within five days after occurrence of loss to the Owner's exercise of this power; if such objection is made, the dispute shall be resolved in the manner selected by the Owner and Contractor as the method of binding dispute resolution in the Agreement. If the Owner and Contractor have selected arbitration as the method of binding dispute resolution, the Owner as fiduciary shall make settlement with insurers or, in the case of a dispute over distribution of insurance proceeds, in accordance with the directions of the arbitrators.

#### § 11.4 PERFORMANCE BOND AND PAYMENT BOND

§ 11.4.1 The Owner shall have the right to require the Contractor to furnish bonds covering faithful performance of the Contract and payment of obligations arising thereunder as stipulated in bidding requirements or specifically required in the Contract Documents on the date of execution of the Contract.

§ 11.4.2 Upon the request of any person or entity appearing to be a potential beneficiary of bonds covering payment of obligations arising under the Contract, the Contractor shall promptly furnish a copy of the bonds or shall authorize a copy to be furnished.

Init.

**ARTICLE 12 UNCOVERING AND CORRECTION OF WORK**

**§ 12.1 UNCOVERING OF WORK**

**§ 12.1.1** If a portion of the Work is covered contrary to the Architect's request or to requirements specifically expressed in the Contract Documents, it must, if requested in writing by the Architect, be uncovered for the Architect's examination and be replaced at the Contractor's expense without change in the Contract Time.

**§ 12.1.2** If a portion of the Work has been covered that the Architect has not specifically requested to examine prior to its being covered, the Architect may request to see such Work and it shall be uncovered by the Contractor. If such Work is in accordance with the Contract Documents, costs of uncovering and replacement shall, by appropriate Change Order, be at the Owner's expense. If such Work is not in accordance with the Contract Documents, such costs and the cost of correction shall be at the Contractor's expense unless the condition was caused by the Owner or a separate contractor in which event the Owner shall be responsible for payment of such costs.

**§ 12.2 CORRECTION OF WORK**

**§ 12.2.1 BEFORE OR AFTER SUBSTANTIAL COMPLETION**

The Contractor shall promptly correct Work rejected by the Architect or failing to conform to the requirements of the Contract Documents, whether discovered before or after Substantial Completion and whether or not fabricated, installed or completed. Costs of correcting such rejected Work, including additional testing and inspections, the cost of uncovering and replacement, and compensation for the Architect's services and expenses made necessary thereby, shall be at the Contractor's expense.

**§ 12.2.2 AFTER SUBSTANTIAL COMPLETION**

**§ 12.2.2.1** In addition to the Contractor's obligations under Section 3.5, if, within one year after the date of Substantial Completion of the Work or designated portion thereof or after the date for commencement of warranties established under Section 9.9.1, or by terms of an applicable special warranty required by the Contract Documents, any of the Work is found to be not in accordance with the requirements of the Contract Documents, the Contractor shall correct it promptly after receipt of written notice from the Owner to do so unless the Owner has previously given the Contractor a written acceptance of such condition. The Owner shall give such notice promptly after discovery of the condition. During the one-year period for correction of Work, if the Owner fails to notify the Contractor and give the Contractor an opportunity to make the correction, the Owner waives the rights to require correction by the Contractor and to make a claim for breach of warranty. If the Contractor fails to correct nonconforming Work within a reasonable time during that period after receipt of notice from the Owner or Architect, the Owner may correct it in accordance with Section 2.4.

**§ 12.2.2.2** The one-year period for correction of Work shall be extended with respect to portions of Work first performed after Substantial Completion by the period of time between Substantial Completion and the actual completion of that portion of the Work.

**§ 12.2.2.3** The one-year period for correction of Work shall not be extended by corrective Work performed by the Contractor pursuant to this Section 12.2.

**§ 12.2.3** The Contractor shall remove from the site portions of the Work that are not in accordance with the requirements of the Contract Documents and are neither corrected by the Contractor nor accepted by the Owner.

**§ 12.2.4** The Contractor shall bear the cost of correcting destroyed or damaged construction, whether completed or partially completed, of the Owner or separate contractors caused by the Contractor's correction or removal of Work that is not in accordance with the requirements of the Contract Documents.

**§ 12.2.5** Nothing contained in this Section 12.2 shall be construed to establish a period of limitation with respect to other obligations the Contractor has under the Contract Documents. Establishment of the one-year period for correction of Work as described in Section 12.2.2 relates only to the specific obligation of the Contractor to correct the Work, and has no relationship to the time within which the obligation to comply with the Contract Documents may be sought to be enforced, nor to the time within which proceedings may be commenced to establish the Contractor's liability with respect to the Contractor's obligations other than specifically to correct the Work.

Init.

### § 12.3 ACCEPTANCE OF NONCONFORMING WORK

If the Owner prefers to accept Work that is not in accordance with the requirements of the Contract Documents, the Owner may do so instead of requiring its removal and correction, in which case the Contract Sum will be reduced as appropriate and equitable. Such adjustment shall be effected whether or not final payment has been made.

## ARTICLE 13 MISCELLANEOUS PROVISIONS

### § 13.1 GOVERNING LAW

The Contract shall be governed by the law of the place where the Project is located except that, if the parties have selected arbitration as the method of binding dispute resolution, the Federal Arbitration Act shall govern Section 15.4.

### § 13.2 SUCCESSORS AND ASSIGNS

§ 13.2.1 The Owner and Contractor respectively bind themselves, their partners, successors, assigns and legal representatives to covenants, agreements and obligations contained in the Contract Documents. Except as provided in Section 13.2.2, neither party to the Contract shall assign the Contract as a whole without written consent of the other. If either party attempts to make such an assignment without such consent, that party shall nevertheless remain legally responsible for all obligations under the Contract.

§ 13.2.2 The Owner may, without consent of the Contractor, assign the Contract to a lender providing construction financing for the Project, if the lender assumes the Owner's rights and obligations under the Contract Documents. The Contractor shall execute all consents reasonably required to facilitate such assignment.

### § 13.3 WRITTEN NOTICE

Written notice shall be deemed to have been duly served if delivered in person to the individual, to a member of the firm or entity, or to an officer of the corporation for which it was intended; or if delivered at, or sent by registered or certified mail or by courier service providing proof of delivery to, the last business address known to the party giving notice.

### § 13.4 RIGHTS AND REMEDIES

§ 13.4.1 Duties and obligations imposed by the Contract Documents and rights and remedies available thereunder shall be in addition to and not a limitation of duties, obligations, rights and remedies otherwise imposed or available by law.

§ 13.4.2 No action or failure to act by the Owner, Architect or Contractor shall constitute a waiver of a right or duty afforded them under the Contract, nor shall such action or failure to act constitute approval of or acquiescence in a breach there under, except as may be specifically agreed in writing.

### § 13.5 TESTS AND INSPECTIONS

§ 13.5.1 Tests, inspections and approvals of portions of the Work shall be made as required by the Contract Documents and by applicable laws, statutes, ordinances, codes, rules and regulations or lawful orders of public authorities. Unless otherwise provided, the Contractor shall make arrangements for such tests, inspections and approvals with an independent testing laboratory or entity acceptable to the Owner, or with the appropriate public authority, and shall bear all related costs of tests, inspections and approvals. The Contractor shall give the Architect timely notice of when and where tests and inspections are to be made so that the Architect may be present for such procedures. The Owner shall bear costs of (1) tests, inspections or approvals that do not become requirements until after bids are received or negotiations concluded, and (2) tests, inspections or approvals where building codes or applicable laws or regulations prohibit the Owner from delegating their cost to the Contractor.

§ 13.5.2 If the Architect, Owner or public authorities having jurisdiction determine that portions of the Work require additional testing, inspection or approval not included under Section 13.5.1, the Architect will, upon written authorization from the Owner, instruct the Contractor to make arrangements for such additional testing, inspection or approval by an entity acceptable to the Owner, and the Contractor shall give timely notice to the Architect of when and where tests and inspections are to be made so that the Architect may be present for such procedures. Such costs, except as provided in Section 13.5.3, shall be at the Owner's expense.

§ 13.5.3 If such procedures for testing, inspection or approval under Sections 13.5.1 and 13.5.2 reveal failure of the portions of the Work to comply with requirements established by the Contract Documents, all costs made necessary by

such failure including those of repeated procedures and compensation for the Architect's services and expenses shall be at the Contractor's expense.

§ 13.5.4 Required certificates of testing, inspection or approval shall, unless otherwise required by the Contract Documents, be secured by the Contractor and promptly delivered to the Architect.

§ 13.5.5 If the Architect is to observe tests, inspections or approvals required by the Contract Documents, the Architect will do so promptly and, where practicable, at the normal place of testing.

§ 13.5.6 Tests or inspections conducted pursuant to the Contract Documents shall be made promptly to avoid unreasonable delay in the Work.

#### § 13.6 INTEREST

Payments due and unpaid under the Contract Documents shall bear interest from the date payment is due at such rate as the parties may agree upon in writing or, in the absence thereof, at the legal rate prevailing from time to time at the place where the Project is located.

#### § 13.7 TIME LIMITS ON CLAIMS

The Owner and Contractor shall commence all claims and causes of action, whether in contract, tort, breach of warranty or otherwise, against the other arising out of or related to the Contract in accordance with the requirements of the final dispute resolution method selected in the Agreement within the time period specified by applicable law, but in any case not more than 10 years after the date of Substantial Completion of the Work. The Owner and Contractor waive all claims and causes of action not commenced in accordance with this Section 13.7.

### ARTICLE 14 TERMINATION OR SUSPENSION OF THE CONTRACT

#### § 14.1 TERMINATION BY THE CONTRACTOR

§ 14.1.1 The Contractor may terminate the Contract if the Work is stopped for a period of 30 consecutive days through no act or fault of the Contractor or a Subcontractor, Sub-subcontractor or their agents or employees or any other persons or entities performing portions of the Work under direct or indirect contract with the Contractor, for any of the following reasons:

- .1 Issuance of an order of a court or other public authority having jurisdiction that requires all Work to be stopped;
- .2 An act of government, such as a declaration of national emergency that requires all Work to be stopped;
- .3 Because the Architect has not issued a Certificate for Payment and has not notified the Contractor of the reason for withholding certification as provided in Section 9.4.1, or because the Owner has not made payment on a Certificate for Payment within the time stated in the Contract Documents; or
- .4 The Owner has failed to furnish to the Contractor promptly, upon the Contractor's request, reasonable evidence as required by Section 2.2.1.

§ 14.1.2 The Contractor may terminate the Contract if, through no act or fault of the Contractor or a Subcontractor, Sub-subcontractor or their agents or employees or any other persons or entities performing portions of the Work under direct or indirect contract with the Contractor, repeated suspensions, delays or interruptions of the entire Work by the Owner as described in Section 14.3 constitute in the aggregate more than 100 percent of the total number of days scheduled for completion, or 120 days in any 365-day period, whichever is less.

§ 14.1.3 If one of the reasons described in Section 14.1.1 or 14.1.2 exists, the Contractor may, upon seven days' written notice to the Owner and Architect, terminate the Contract and recover from the Owner payment for Work executed, including reasonable overhead and profit, costs incurred by reason of such termination, and damages.

§ 14.1.4 If the Work is stopped for a period of 60 consecutive days through no act or fault of the Contractor or a Subcontractor or their agents or employees or any other persons performing portions of the Work under contract with the Contractor because the Owner has repeatedly failed to fulfill the Owner's obligations under the Contract Documents with respect to matters important to the progress of the Work, the Contractor may, upon seven additional days' written notice to the Owner and the Architect, terminate the Contract and recover from the Owner as provided in Section 14.1.3.

**§ 14.2 TERMINATION BY THE OWNER FOR CAUSE**

**§ 14.2.1** The Owner may terminate the Contract if the Contractor

- .1 repeatedly refuses or fails to supply enough properly skilled workers or proper materials;
- .2 fails to make payment to Subcontractors for materials or labor in accordance with the respective agreements between the Contractor and the Subcontractors;
- .3 repeatedly disregards applicable laws, statutes, ordinances, codes, rules and regulations, or lawful orders of a public authority; or
- .4 otherwise is guilty of substantial breach of a provision of the Contract Documents.

**§ 14.2.2** When any of the above reasons exist, the Owner, upon certification by the Initial Decision Maker that sufficient cause exists to justify such action, may without prejudice to any other rights or remedies of the Owner and after giving the Contractor and the Contractor's surety, if any, seven days' written notice, terminate employment of the Contractor and may, subject to any prior rights of the surety:

- .1 Exclude the Contractor from the site and take possession of all materials, equipment, tools, and construction equipment and machinery thereon owned by the Contractor;
- .2 Accept assignment of subcontracts pursuant to Section 5.4; and
- .3 Finish the Work by whatever reasonable method the Owner may deem expedient. Upon written request of the Contractor, the Owner shall furnish to the Contractor a detailed accounting of the costs incurred by the Owner in finishing the Work.

**§ 14.2.3** When the Owner terminates the Contract for one of the reasons stated in Section 14.2.1, the Contractor shall not be entitled to receive further payment until the Work is finished.

**§ 14.2.4** If the unpaid balance of the Contract Sum exceeds costs of finishing the Work, including compensation for the Architect's services and expenses made necessary thereby, and other damages incurred by the Owner and not expressly waived, such excess shall be paid to the Contractor. If such costs and damages exceed the unpaid balance, the Contractor shall pay the difference to the Owner. The amount to be paid to the Contractor or Owner, as the case may be, shall be certified by the Initial Decision Maker, upon application, and this obligation for payment shall survive termination of the Contract.

**§ 14.3 SUSPENSION BY THE OWNER FOR CONVENIENCE**

**§ 14.3.1** The Owner may, without cause, order the Contractor in writing to suspend, delay or interrupt the Work in whole or in part for such period of time as the Owner may determine.

**§ 14.3.2** The Contract Sum and Contract Time shall be adjusted for increases in the cost and time caused by suspension, delay or interruption as described in Section 14.3.1. Adjustment of the Contract Sum shall include profit. No adjustment shall be made to the extent

- .1 that performance is, was or would have been so suspended, delayed or interrupted by another cause for which the Contractor is responsible; or
- .2 that an equitable adjustment is made or denied under another provision of the Contract.

**§ 14.4 TERMINATION BY THE OWNER FOR CONVENIENCE**

**§ 14.4.1** The Owner may, at any time, terminate the Contract for the Owner's convenience and without cause.

**§ 14.4.2** Upon receipt of written notice from the Owner of such termination for the Owner's convenience, the Contractor shall

- .1 cease operations as directed by the Owner in the notice;
- .2 take actions necessary, or that the Owner may direct, for the protection and preservation of the Work; and
- .3 except for Work directed to be performed prior to the effective date of termination stated in the notice, terminate all existing subcontracts and purchase orders and enter into no further subcontracts and purchase orders.

**§ 14.4.3** In case of such termination for the Owner's convenience, the Contractor shall be entitled to receive payment for Work executed, and costs incurred by reason of such termination, along with reasonable overhead and profit on the Work not executed.

Init.



## ARTICLE 15 CLAIMS AND DISPUTES

### § 15.1 CLAIMS

#### § 15.1.1 DEFINITION

A Claim is a demand or assertion by one of the parties seeking, as a matter of right, payment of money, or other relief with respect to the terms of the Contract. The term "Claim" also includes other disputes and matters in question between the Owner and Contractor arising out of or relating to the Contract. The responsibility to substantiate Claims shall rest with the party making the Claim.

#### § 15.1.2 NOTICE OF CLAIMS

Claims by either the Owner or Contractor must be initiated by written notice to the other party and to the Initial Decision Maker with a copy sent to the Architect, if the Architect is not serving as the Initial Decision Maker. Claims by either party must be initiated within 21 days after occurrence of the event giving rise to such Claim or within 21 days after the claimant first recognizes the condition giving rise to the Claim, whichever is later.

#### § 15.1.3 CONTINUING CONTRACT PERFORMANCE

Pending final resolution of a Claim, except as otherwise agreed in writing or as provided in Section 9.7 and Article 14, the Contractor shall proceed diligently with performance of the Contract and the Owner shall continue to make payments in accordance with the Contract Documents. The Architect will prepare Change Orders and issue Certificates for Payment in accordance with the decisions of the Initial Decision Maker.

#### § 15.1.4 CLAIMS FOR ADDITIONAL COST

If the Contractor wishes to make a Claim for an increase in the Contract Sum, written notice as provided herein shall be given before proceeding to execute the Work. Prior notice is not required for Claims relating to an emergency endangering life or property arising under Section 10.4.

#### § 15.1.5 CLAIMS FOR ADDITIONAL TIME

§ 15.1.5.1 If the Contractor wishes to make a Claim for an increase in the Contract Time, written notice as provided herein shall be given. The Contractor's Claim shall include an estimate of cost and of probable effect of delay on progress of the Work. In the case of a continuing delay, only one Claim is necessary.

§ 15.1.5.2 If adverse weather conditions are the basis for a Claim for additional time, such Claim shall be documented by data substantiating that weather conditions were abnormal for the period of time, could not have been reasonably anticipated and had an adverse effect on the scheduled construction.

#### § 15.1.6 CLAIMS FOR CONSEQUENTIAL DAMAGES

The Contractor and Owner waive Claims against each other for consequential damages arising out of or relating to this Contract. This mutual waiver includes

- .1 damages incurred by the Owner for rental expenses, for losses of use, income, profit, financing, business and reputation, and for loss of management or employee productivity or of the services of such persons; and
- .2 damages incurred by the Contractor for principal office expenses including the compensation of personnel stationed there, for losses of financing, business and reputation, and for loss of profit except anticipated profit arising directly from the Work.

This mutual waiver is applicable, without limitation, to all consequential damages due to either party's termination in accordance with Article 14. Nothing contained in this Section 15.1.6 shall be deemed to preclude an award of liquidated damages, when applicable, in accordance with the requirements of the Contract Documents.

### § 15.2 INITIAL DECISION

§ 15.2.1 Claims, excluding those arising under Sections 10.3, 10.4, 11.3.9, and 11.3.10, shall be referred to the Initial Decision Maker for initial decision. The Architect will serve as the Initial Decision Maker, unless otherwise indicated in the Agreement. Except for those Claims excluded by this Section 15.2.1, an initial decision shall be required as a condition precedent to mediation of any Claim arising prior to the date final payment is due, unless 30 days have passed after the Claim has been referred to the Initial Decision Maker with no decision having been rendered. Unless the Initial Decision Maker and all affected parties agree, the Initial Decision Maker will not decide disputes between the Contractor and persons or entities other than the Owner.

§ 15.2.2 The Initial Decision Maker will review Claims and within ten days of the receipt of a Claim take one or more of the following actions: (1) request additional supporting data from the claimant or a response with supporting data from the other party, (2) reject the Claim in whole or in part, (3) approve the Claim, (4) suggest a compromise, or (5) advise the parties that the Initial Decision Maker is unable to resolve the Claim if the Initial Decision Maker lacks sufficient information to evaluate the merits of the Claim or if the Initial Decision Maker concludes that, in the Initial Decision Maker's sole discretion, it would be inappropriate for the Initial Decision Maker to resolve the Claim.

§ 15.2.3 In evaluating Claims, the Initial Decision Maker may, but shall not be obligated to, consult with or seek information from either party or from persons with special knowledge or expertise who may assist the Initial Decision Maker in rendering a decision. The Initial Decision Maker may request the Owner to authorize retention of such persons at the Owner's expense.

§ 15.2.4 If the Initial Decision Maker requests a party to provide a response to a Claim or to furnish additional supporting data, such party shall respond, within ten days after receipt of such request, and shall either (1) provide a response on the requested supporting data, (2) advise the Initial Decision Maker when the response or supporting data will be furnished or (3) advise the Initial Decision Maker that no supporting data will be furnished. Upon receipt of the response or supporting data, if any, the Initial Decision Maker will either reject or approve the Claim in whole or in part.

§ 15.2.5 The Initial Decision Maker will render an initial decision approving or rejecting the Claim, or indicating that the Initial Decision Maker is unable to resolve the Claim. This initial decision shall (1) be in writing; (2) state the reasons therefor; and (3) notify the parties and the Architect, if the Architect is not serving as the Initial Decision Maker, of any change in the Contract Sum or Contract Time or both. The initial decision shall be final and binding on the parties but subject to mediation and, if the parties fail to resolve their dispute through mediation, to binding dispute resolution.

§ 15.2.6 Either party may file for mediation of an initial decision at any time, subject to the terms of Section 15.2.6.1.

§ 15.2.6.1 Either party may, within 30 days from the date of an initial decision, demand in writing that the other party file for mediation within 60 days of the initial decision. If such a demand is made and the party receiving the demand fails to file for mediation within the time required, then both parties waive their rights to mediate or pursue binding dispute resolution proceedings with respect to the initial decision.

§ 15.2.7 In the event of a Claim against the Contractor, the Owner may, but is not obligated to, notify the surety, if any, of the nature and amount of the Claim. If the Claim relates to a possibility of a Contractor's default, the Owner may, but is not obligated to, notify the surety and request the surety's assistance in resolving the controversy.

§ 15.2.8 If a Claim relates to or is the subject of a mechanic's lien, the party asserting such Claim may proceed in accordance with applicable law to comply with the lien notice or filing deadlines.

### § 15.3 MEDIATION

§ 15.3.1 Claims, disputes, or other matters in controversy arising out of or related to the Contract except those waived as provided for in Sections 9.10.4, 9.10.5, and 15.1.6 shall be subject to mediation as a condition precedent to binding dispute resolution.

§ 15.3.2 The parties shall endeavor to resolve their Claims by mediation which, unless the parties mutually agree otherwise, shall be administered by the American Arbitration Association in accordance with its Construction Industry Mediation Procedures in effect on the date of the Agreement. A request for mediation shall be made in writing, delivered to the other party to the Contract, and filed with the person or entity administering the mediation. The request may be made concurrently with the filing of binding dispute resolution proceedings but, in such event, mediation shall proceed in advance of binding dispute resolution proceedings, which shall be stayed pending mediation for a period of 60 days from the date of filing, unless stayed for a longer period by agreement of the parties or court order. If an arbitration is stayed pursuant to this Section 15.3.2, the parties may nonetheless proceed to the selection of the arbitrator(s) and agree upon a schedule for later proceedings.

§ 15.3.3 The parties shall share the mediator's fee and any filing fees equally. The mediation shall be held in the place where the Project is located, unless another location is mutually agreed upon. Agreements reached in mediation shall be enforceable as settlement agreements in any court having jurisdiction thereof.

**§ 15.4 ARBITRATION**

§ 15.4.1 If the parties have selected arbitration as the method for binding dispute resolution in the Agreement, any Claim subject to, but not resolved by, mediation shall be subject to arbitration which, unless the parties mutually agree otherwise, shall be administered by the American Arbitration Association in accordance with its Construction Industry Arbitration Rules in effect on the date of the Agreement. A demand for arbitration shall be made in writing, delivered to the other party to the Contract, and filed with the person or entity administering the arbitration. The party filing a notice of demand for arbitration must assert in the demand all Claims then known to that party on which arbitration is permitted to be demanded.

§ 15.4.1.1 A demand for arbitration shall be made no earlier than concurrently with the filing of a request for mediation, but in no event shall it be made after the date when the institution of legal or equitable proceedings based on the Claim would be barred by the applicable statute of limitations. For statute of limitations purposes, receipt of a written demand for arbitration by the person or entity administering the arbitration shall constitute the institution of legal or equitable proceedings based on the Claim.

§ 15.4.2 The award rendered by the arbitrator or arbitrators shall be final, and judgment may be entered upon it in accordance with applicable law in any court having jurisdiction thereof.

§ 15.4.3 The foregoing agreement to arbitrate and other agreements to arbitrate with an additional person or entity duly consented to by parties to the Agreement shall be specifically enforceable under applicable law in any court having jurisdiction thereof.

**§ 15.4.4 CONSOLIDATION OR JOINDER**

§ 15.4.4.1 Either party, at its sole discretion, may consolidate an arbitration conducted under this Agreement with any other arbitration to which it is a party provided that (1) the arbitration agreement governing the other arbitration permits consolidation, (2) the arbitrations to be consolidated substantially involve common questions of law or fact, and (3) the arbitrations employ materially similar procedural rules and methods for selecting arbitrator(s).

§ 15.4.4.2 Either party, at its sole discretion, may include by joinder persons or entities substantially involved in a common question of law or fact whose presence is required if complete relief is to be accorded in arbitration, provided that the party sought to be joined consents in writing to such joinder. Consent to arbitration involving an additional person or entity shall not constitute consent to arbitration of any claim, dispute or other matter in question not described in the written consent.

§ 15.4.4.3 The Owner and Contractor grant to any person or entity made a party to an arbitration conducted under this Section 15.4, whether by joinder or consolidation, the same rights of joinder and consolidation as the Owner and Contractor under this Agreement.



## SUPPLEMENTARY CONDITIONS

### SUPPLEMENTARY CONDITIONS

*The following supplements modify, change, delete from or add to the General Conditions of the Contract for Construction, A.I.A. Document A201, 2007 (thereafter referred to as "The General Conditions"). Where any Article of the General Conditions is modified or any paragraph, subparagraph or clause thereof is modified or deleted by these supplements, the unaltered provisions of that article, paragraph, subparagraph or clause shall remain in effect.*

*Numerical designations herein have the same, or are a sequential developmental of the same designations as the General Conditions.*

### ARTICLE 1 – GENERAL PROVISIONS

Add the following Subparagraph 1.1.1.1:

1. Where discrepancies or conflicts occur:
  - (a) Addenda shall take precedence over Drawings or Specifications.
  - (b) Specifications shall take precedence over Drawings.
  - (c) Stated dimensions shall take precedence over dimensions obtained by scaling.
  - (d) Large-scale detail drawings shall take precedence over small-scale drawings.

### ARTICLE 3 – CONTRACTOR

Add the following Subparagraphs to 3.15:

3.15.3 The Contractor shall remove and dispose of all construction debris at the end of each day.

3.15.4 All dumpsters shall be emptied and/or replaced and all rubbish removed at the end of each week.

Add the following Subparagraphs to 3.3:

3.3.4 The Contractor shall verify all measurements at the Project and shall be responsible for their accuracy. No increase in the Contract Sum will be allowed for additional work required due to differences between field dimensions and Drawing Documents or stated approximate quantities.

3.3.5 The Contractor shall consult with representatives of all Subcontractors to avoid interference. The Contractor shall rearrange any work which may cause interference with work of other trade, without increase in contract Sum.

Add the following Subparagraphs to 3.9:

3.9.2 Once assigned, the Project Superintendent may not be changed without the approval of the Owner and Architect.

3.9.3 Project Superintendent must attend all Project meetings.

Add the following Subparagraph to 3.18:

3.18.3 Unless otherwise stated in the Agreement, each respective Contractor shall, before commencing work, secure and pay for such insurance as may be required to comply with the indemnification and hold harmless provisions outlined under Articles 3.18.1 and 3.18.2.

Such insurance shall be with such companies as may be satisfactory to the Owner. Insurance shall be so written as to prevent cancellation without at least thirty (30) days written notice to the Owner, Architect and Contractor.

#### **ARTICLE 7 – CHANGES IN THE WORK**

Add the following Subparagraph to 7.3.6:

7.3.6.1 The allowance for the overhead and profit combined, included in the total cost to the Owner shall be based on the following:

1. For the Contractor, for any work performed by the Contractor's own forces 15 percent of this total direct cost.
2. For work performed by a Subcontractor, 5 percent (5%) of the amount of the Subcontractor's total direct costs (not including Subcontractor's overhead and profit).

#### **ARTICLE 9 – PAYMENTS AND COMPLETION Add**

the following sentence to 9.3.1:

The form of application for payment shall be AIA Document G702, "Application and Certification for Payment," supported by AIA Document G703, "Continuation Sheet." Two (2) copies of the Application for Payment shall be submitted and sworn before a Notary Public.

Add the following clause to 9.3.1:

Payments to the Contractor shall include five percent (5%) retainage and shall be as follows:

1. Monthly progress payments bringing total payments to ninety-five percent (95%) of the contract amount upon final acceptance by the Owner and Architect.
2. Payment of five percent (5%) retainage no later than forty five (45) days after final payment and upon receipt of warranties, operational and maintenance manual and record drawings.

Add the following to Subparagraph to 9.3.3:

The Contractor further agrees that the submission of any Application for Payment shall, upon receipt of such payment and to the fullest extent permitted by law, be conclusively deemed to waive all liens with respect to said work, materials and labor to which the Contractor then may be entitled; provided, however, that in no event shall such waiver of lien rights waive right to payment for said work, materials and labor.

**ARTICLE 11 – INSURANCE AND BONDS**

Add the following clause to 11.1:

11.1.1.9 Liability Insurance shall include all major divisions of coverage and be on a comprehensive basis including:

1. Premises Operation (including X, C and U coverage as applicable).
2. Independent Contractor’s Protective.
3. Products and Completed Operations.
4. Personal Injury Liability with Employment Exclusion deleted.
5. Contractual, including specified provision for Contractors.
6. Owned, Non-owned and Hired Motor Vehicles.
7. Broad Form Property Damage including Completed Operations.

11.1.2.1 If the General Liability coverage is provided by a Commercial General Liability Policy on a “claims-made” basis, the policy date shall predate the Contract termination date of the policy or applicable extended reporting period shall be no earlier than the termination date of coverage required to be maintained after final payment certified in accordance with Subparagraph 9.10.2.

11.1.2.1 Refer to Instructions to Bidders contained in Project Manual for coverage requirements.

Additionally named insured:

Town of Stratford  
2725 Main Street  
Stratford, CT 06615

Snyder Architects, LLC  
Trumbull, CT 06611

Including employees, consultants and agents of the above parties.

1. The Contractor shall provide adequate Fire and Extended Coverage insurance to cover equipment, tools, etc., owned or rented by him, his Subcontractors, the capital value of which is not included in the work, and those materials stored on the site for which payment by the Owner has not been approved. Such coverage shall include an endorsement to the effect that the Underwriter waives their rights of subrogation against the Owner.

- 2. The Contractor agrees to secure and protect himself, and shall secure and indemnify the Owner and his representatives or employees from any claim of liability, expense, cause of action, loss or damage whatsoever for any injury, including death, to any person or property in the performance of this Contract; it being the intent of this Agreement to protect and indemnify the Owner from any and all loss arising out of or in connection with, the work performed under this Contract.

11.1.4 Contractor's liability insurance must be maintained until final Certificate of Payment is issued pursuant to paragraph 9.10.2 and completed Operators Insurance is in effect

11.1.5 Certificates of Insurance must be submitted on AIA Document G715 Certificate of Insurance or such other form as acceptable to the owner and Architect.

**ARTICLE 13 – MISCELLANEOUS PROVISIONS**

Add the following to Paragraph 13.1.1:

13.1.1.2 The Contractor and his Subcontractors shall abide by Sections 46a-51, 46a, 60,61 and 62 of the Connecticut General Statutes "Discriminatory Practices."

13.1.1.3 The Contractor and all Subcontractors shall comply with all applicable requirements of paragraph 814c "Human Rights and Opportunities" of the Connecticut General Statutes.

**ADD THE FOLLOWING ARTICLE 15.**

**ARTICLE 15 – CERTIFIED GUARANTEE AND WARRANTY TO OWNER**

15.1 The Contractor shall provide a project Guarantee/Warranty on his letterhead in the general format shown on the following page.

(CONTRACTOR'S LETTERHEAD)

NAME AND ADDRESS OF OWNER

Date: \_\_\_\_\_

Re: \_\_\_\_\_

(Name of Project)

Gentlemen:



The undersigned guarantees the Owner that he will be responsible for faulty materials, equipment and workmanship and that he will remedy all defects due thereto and pay for all damages to other work resulting therefrom which shall appear within a period of two (2) years from the date at which Substantial Completion of the work is certified by the Architect.

During this period, upon written notice, the undersigned will proceed with due diligence at the undersigned's expense to replace properly all defective materials and equipment and perform all labor necessary to correct all defects in the work.

In case the undersigned fails upon reasonable notice to remedy such defects, the owner may, in addition to and without limitation of any other rights or remedies the Owner may have, furnish such materials or labor as are necessary to do so, and the undersigned agrees to reimburse the Owner fully and promptly upon demand.

Guarantees from Contractor shall be supported by individual guarantees from each trade or subcontractor and manufacturer or supplier covering work performed and material and equipment.

All materials, fixtures, appliances, equipment and other items requiring excessive servicing during the guarantee period, in the opinion of the Architect, will be considered defective, and shall be made good, replaced and/or corrected, to the satisfaction of the Architect and Owner, under the terms of this paragraph.

The furnishing of the above guarantee, and all other special guarantees required by the Contract Documents, shall be a condition precedent to payment of retainage.

\_\_\_\_\_  
(Signature of Contractor)

(Notarized)

\_\_\_\_\_

**END OF SUPPLEMENTARY CONDITIONS**



**INSURANCE PROCEDURE**

**PLEASE NOTE:**

**THIS PAGE MUST BE RETURNED WITH YOUR BID/PROPOSAL. FAILURE TO DO SO MAY RESULT IN YOUR BID/PROPOSAL BEING REJECTED.**

Please take the insurance requirements of the Contract to your agent/broker immediately upon receipt of the bid documents to determine your existing coverage and any costs for new or additional coverage required for the work noted in this Request for Bid/Proposal. Any bids/proposals with deficient insurance requirements will be rejected.

**STATEMENT OF VENDOR:**

I have read the insurance requirements for this work and have taken the documentation to my insurance agent/broker. The bid/proposal cost reflects any additional costs relating to insurance requirements for this work.

\_\_\_\_\_  
Signature

\_\_\_\_\_  
Date

\_\_\_\_\_  
Contractor

**(SAMPLE ENDORSEMENT LETTER)**

**AGENT/BROKER  
(LETTERHEAD)**

(Date)

Mr. Phillip Ryan  
Purchasing Agent  
Purchasing Department  
Town of Stratford  
2725 Main Street  
Stratford, CT 06615

Re:

**Town of Stratford Contract # \_\_\_\_\_  
(Name of Contract)**

Dear Mr. Ryan:

The undersigned hereby certifies as follows:

- (1) I am a duly licensed insurance agent under the laws of the State of [insert State] and an authorized representative of all companies affording coverage under the Acord form submitted herewith;
- (2) The Town of Stratford has been endorsed as an additional insured under the general liability policy no. [insert policy number], issued by [insert company affording coverage] to [name of insured];
- (3) The general liability policy referenced in paragraph (2) above meets or exceeds the coverage in Commercial General Liability ISO form CG 00 01 10 01, including contractual liability;
- (4) The policies listed in the Acord form submitted to the Town of Stratford in connection with the above-referenced contract have been issued to the insured in the amounts stated and for the periods indicated in the Acord form; and
- (5) The Town of Stratford shall be given thirty (30) days prior written notice of cancellation, lapse or restrictive amendment (except ten days notice of nonpayment) of the policies listed in the Acord form.

Sincerely,

Authorized Representative for all companies listed in the Acord form

**ACORD**

**CERTIFICATE OF LIABILITY INSURANCE**

PRODUCER	THIS CERTIFICATE IS ISSUED AS A MATTER OF INFORMATION ONLY AND CONFERS NO RIGHTS UPON THE CERTIFICATE HOLDER, THIS CERTIFICATE DOES NOT AMEND, EXTEND OR ALTER THE COVERAGE AFFORDED BY THE POLICIES BELOW.	
	INSUREERS AFFORDING COVERAGE	
INSURED	<u>CONTRACT</u>	INSURER A:
		INSURER B:
		INSURER C:
		INSURER D:
		INSURER E:

**COVERAGES**  
 THE POLICIES OF INSURANCE LISTED BELOW HAVE BEEN ISSUED TO THE INSURED NAMED ABOVE FOR THE POLICY PERIOD INDICATED, NOTWITHSTANDING ANY REQUIREMENT, TERM OF CONDITION OF ANY CONTRACT OR OTHER DOCUMENT WITH RESPECT TO WHICH THIS CERTIFICATE MAY BE ISSUED OR MAY PERTAIN, THE INSURANCE AFFORDED BY THE POLICIES DESCRIBED HEREIN IS SUBJECT TO ALL THE TERMS, EXCLUSIONS AND CONDITIONS OF SUCH POLICIES. LIMITS SHOWN MAY HAVE BEEN REDUCED BY PAID CLAIMS.

IN SR LT	TYPE OF INSURANCE	POLICY NUMBER	POLICY EFFECTIVE DATE(MM/DD/YY)	POLICY EXPIRATION DATE(MM/DD/YY)	LIMITS
	GENERAL LIABILITY COMMERCIAL GENERAL " CLAIMS MADE T OCCUR " " GENERAL AGGREGATE LIMIT " POLICY " PROJECT " LOC				EACH OCCURENCE FIRE DAMAGE (Any one fire) MED EXP (Any one person) PERSONAL & ADV INJURY GENERAL AGGRREGATE PRODUCTS-COMP/OP AGG
	AUTOMOBILE LIABILITY " ANY AUTO ALL OWNED AUTOS " SCHEDULED AUTOS HIRED AUTOS NON-OWNED AUTOS " "				COMBINED SINGLE LIMIT (Ea accident) BODILY INJURY (Per person) BODILY INJURY (Per accident) PROPERTY DAMAGE (Per accident)
	GARAGE LIABILITY " ANY AUTO "				AUTO ONLY-EA ACCIDENT OTHER THAN EA ACC AUTO ONLY: AGG
	EXCESS LIABILITY " OCCUR " CLAIMS MADE " " DEDUCTIBLE " RETENTION \$				EACH OCCURRENCE AGGREGATE
	WORKERS COMPENSATION AND EMPLOYERS' LIABILITY				WC STATUORY LIMITS OTHER E.L. EACH ACCIDENT E.L. DISEASE-EA EMPLOYEE E.L. DISEASE - POLICY LIMIT
	Professional Liability				

**DESCRIPTION OF OPERATIONS/LOCATIONS/VEHICLES/EXCLUSIONS ADDED BY ENDORSEMENT/SPECIAL PROVISIONS**  
 Contract # \_\_\_\_\_

CERTIFICATE HOLDER  ADDITIONAL INSURED; INSURER LETTER: \_\_\_ CANCELLATION

Certificate Holder: <b>Town of Stratford</b> <b>2725 Main Street</b> <b>Stratford, CT 06615</b> & <b>The State of Connecticut</b>	SHOULD ANY OF THE ABOVE DESCRIBED POLICIES BE CANCELLED BEFORE THE EXPIRATION DATE THEREOF, THE ISSUING COMPANY WILL ENDEAVOR TO MAIL 30 DAYS WRITTEN NOTICE TO THE CERTIFICATE HOLDER NAMED TO THE LEFT, BUT FAILURE TO DO SO SHALL IMPOSE NO OBLIGATION OR LIABILITY OF ANY KIND UPON THE INSURER, ITS AGENTS OF REPRESENTATIONS  AUTHORIZED REPRESETNATIVE
3	

**A. M. BEST KEY RATING GUIDE FORM**

The \_\_\_\_\_ is licensed in  
**The State of Connecticut as per listing in the 2008 edition of the  
A.M. Best Key Rating Guide for Property and Casualty, page  
**Number \_\_\_\_\_.****

**Their rating is \_\_\_\_\_.**

**PRE-RENOVATION ROOF ASBESTOS INSPECTION**

**PERFORMED AT:**

**Stratford Academy/Johnson House  
719 Birdseye Street  
Stratford, CT**

**PREPARED FOR:  
Mr. Dan Wakeling  
Town of Stratford**

**PREPARED BY:**



**AMC ENVIRONMENTAL, LLC  
P. O. BOX 423  
STRATFORD, CONNECTICUT 06615  
(203) 378-5020**

**Inspection Date: January 15, 2019  
Report Date: February 14, 2019**

## **1.0 INTRODUCTION**

On January 15, 2019 AMC Environmental, LLC conducted a pre-renovation roof asbestos inspection at Stratford Academy/Johnson House, 719 Birdseye Street, Stratford, CT. The scope of this inspection is limited to the materials described below.

### **Asbestos Containing Materials**

The asbestos inspection was conducted in accordance with the USEPA National Emission Standard for Hazardous Air Pollutants Act (NESHAP) as amended November 20, 1990. The NESHAP final rule requires the identification and removal of all regulated ACM in a building prior to removal or demolition.

Asbestos inspection performed by: Jason Pringle  
State of Connecticut licensed Asbestos Inspector  
License # 000269

## **2.0 BUILDING DESCRIPTION**

The subject building located at 719 Birdseye Street, Stratford, CT is a multi story school building of masonry and metal frame construction. The building has seven(7) roofs with several different types of multi layer built up roofing.

## **3.0 ASBESTOS CONTAINING MATERIALS**

### **Inspection**

This asbestos-containing materials inspection was limited to the accessible areas of the commercial property. Semi-destructive testing techniques are utilized during the inspection process. Suspect building materials that are inaccessible for inspection and sampling are assumed to be ACM for the purpose of this report. These suspect materials are generally located behind rigid walls or ceilings, inside mechanical systems, or in otherwise concealed areas of the building. Please note due to the excessive amount of damage to the building, the inspection was limited to the remaining structure.

During the inspection, the Inspector documents the location, quantity, class, and friability of each suspect material. Friability is an industry term that measures a material's resilience. Material that can be easily crumbled, pulverized, or reduced to powder when dried is defined as being friable. Estimated quantities of identified ACM s are provided for positive material only. Each material is either quantified in square or linear footage, depending on the material.



## **Bulk Sampling**

The United States Environmental Protection Agency (USEPA) has separated ACM into three categories. These categories are: Thermal System Insulation (TSI), Surfacing Materials, and Miscellaneous materials. TSI includes all materials that are used to prevent heat loss or gain, or water condensation on mechanical systems. Examples of TSI are pipe covering, boiler insulation, duct wrap, and mudded fitting cement. Surfacing includes any material that sprayed, troweled, or otherwise to an existing surface. Surfacing applications are commonly used in fireproofing and acoustical applications. All other material falls into the miscellaneous category such as vinyl floor tiles, ceiling tiles and drywall. All sampling methods and sampling quantities are collected at AMC's discretion and meet or exceed requirements set by the USEPA.

## **Bulk Sample Analysis**

Samples of suspect materials are transmitted directly to an independent, State of Connecticut Department of Public Health (DPH), laboratory for analysis by Polarized Light Microscopy (PLM). PLM is the acceptable method of analysis in accordance with the Environmental Protection Agency (EPA) "Interim Method for the Determination of Asbestos in Bulk Insulation", 40 CFR 763, Subpart F, Appendix A EPA 600/M4-82-020. The Inspector collected "sets" of samples for each homogenous material sampled. Each sample is analyzed in the set until one sample is determined to contain asbestos (more than 1%). Sample analyses are reported in percentage of asbestos. The USEPA defines ACM as any material that contains more than 1 % asbestos, by way of PLM. NAD , refers to No asbestos Detected , and DNA refers to "Did Not Analyze" due to stop at first positive. The State of Connecticut Department of Public Health, the USEPA, as well as the United States Department of Labor regulate any material determined to contain greater than 1% of asbestos.

## **Friable ACM**

Other analytical methods are recommended for certain friable material samples. The Point Count Method can further analyze friable materials shown to contain less than 10% asbestos by PLM analysis. Recommended, by the United States Environmental Protection Agency, the Point Count Method is accepted as providing accurate analytical results when determining the percent content of bulk samples with very low asbestos concentrations. Friable material containing less than 1% asbestos must be analyzed by the (PLM) Point Count Method.

## **Non-Friable ACM**

Non-friable asbestos samples showing percentages containing less than 1%, NAD, or TRACE , should be confirmed by the "NOB TEM ELAP 198.4 Method". This procedure is recommended by the USEPA. If the results from this analysis determine asbestos content to still be less than 1 %, the sample is considered not to be asbestos containing.

## **4.0 Conclusion**

During the course of the building inspection, ninety (90) samples of suspect ACM were collected.

From the ninety (90) samples obtained, zero (0) materials were found to be ACM.

A complete inventory of all materials sampled is provided in the tables at the end of the report. Table 1 for asbestos containing materials and **Table 2** non-asbestos containing materials (see **Appendix A** for analytical results).

## 5.0 **RECOMMENDATIONS CONCERNING ASBESTOS**

Laws govern all asbestos activities undertaken in the State of Connecticut. AMC Environmental, LLC suggests the following to ensure compliance with state, federal, or local asbestos regulations and to reduce possible liabilities.

- State of Connecticut, Department of Public Health; Standards for Asbestos Abatement (19a-332-1a through 19a-332a-16).
- State of Connecticut Licensure and Training Requirements for Persons Engaged in Asbestos Abatement and Consultation Services Section 20-440-1 through 20-440-9.
- The Federal Regulation governing asbestos is Title 40 of the Code of Federal Regulations (40 CFR), Part 61, Subpart M, Demolition and/or Renovation of Facilities with Asbestos-Containing Materials.

### **Inaccessible Areas**

All areas appeared to be accessible at the time of the assessment.

### **Disclaimer**

Any work performed by AMC Environmental, LLC was done using the degree of care and skill ordinarily exercised under similar circumstances by members of the profession practicing in the same or similar capacity. The standard of care shall exclusively be judged as of the date of services rendered and not according to later standards. The conclusions and recommendations contained in this report are based on limited environmental sampling and visual observations, and were arrived at in accordance with generally accepted standards of industrial hygiene practice. No other warranty, expressed or implied, is made.

Report Written By: Jason Pringle  
CT Inspector License No. 000269

**TABLE 1**

**ASBESTOS CONTAINING MATERIALS SUMMARY**

**This page was intentionally left blank. There was no asbestos containing material.**

**TABLE 2**

**NON-ASBESTOS CONTAINING MATERIALS**

**TABLE 2**  
NON-ASBESTOS CONTAINING MATERIALS  
SUMMARY TABLE

Stratford Academy/Johnson House Roof

AMC Tracking # ASB1115		Lab: EMSL	Lab # 241900696
Sample #	Sample Location	Sample Description	
B0115-1-1 Insulation, Tar, Felt	Roof 1 Pt 1	Multi-layer Roofing	
B0115-1-2 Insulation, Tar, Felt	Roof 1 Pt. 1	Multi-layer Roofing Bottom Layer	
B0115-1-4	Roof 1 Pt 1	Perelite	
B0115-1-5	Roof 1 Pt 1	Poly ISO Insulation	
B0115-1-6- Insulation,Tar,Felt	Roof 1 Pt 2	Multi-layer Roofing	
B0115-1-7	Roof 1 Pt 2	Perelite	
B0115-1-8	Roof 1 Pt 2	ISO Insulation	
B0115-1-9 Flashing, Tar	Roof 1 Pt 3	Perimeter Flashing	
B0115-2-1	Roof 2 Pt 4	Multi-layer Roofing	
B0115-2-2	Roof 2 Pt 4	Perelite	
B0115-2-3	Roof 2 Pt 4	Poly-ISO	
B0115-2-4 Tar, Felt	Roof 2 Pt 5	Multi-layer Roofing	
B0115-2-5	Roof 2 Pt 5	Perelite	
B0115-2-6	Roof 2 Pt 5	Poly ISO	
B0115-2-7	Roof 2 Pt 6	Perimeter Flashing	
B0115-2-8	Roof 2 Pt 6	Perimeter Flashing Tar	
B0115-2-9 Flashing, Tar	Roof 2 Pt 7	Multi-layer Roofing	
B0115-2-10	Roof 2 Pt 7	Perelite (brown)	
B0115-2-11	Roof 2 Pt 7	Poly ISO (yellow)	
B0115-2-12	Roof 2 Pt 8	Penetration Flashing	
B0115-3-1 Tar, Felt	Roof 3 Pt 9	Multi-layer Roofing	
B0115-3-2	Roof 3 Pt 2	Perelite	
B0115-3-3	Roof 3 Pt 9	Phenolic	
B0115-3-4	Roof 3 Pt 10	Mult-layer Roofing	
B0115-3-4 Felt	Roof 3 Pt 10	Multi-layer Roofing	
B0115-3-5	Roof 3 Pt 10	Perolite	
B0115-3-6	Roof Pt 10	Phenolic (red)	
B01153-7	Roof 3 Pt 10	Poly ISO	
B0115-3-8	Roof 3 Pt 11	Perimeter Flashing	
B0115-3-9	Roof 3 Pt 11	Perolite	
B0115-3-10 Tar, Felt	Roof 3 Pt 12	Multi-layer Roofing	
B0115-3-11	Roof 3 Pt 12	Perolite (brown)	
B0115-3-12	Roof 3 Pt 12	Phenolic (red)	
B0115-3-13	Roof 3 Pt 12	Perolite (brown)	
B0115-3-14	Roof 3 Pt 16	Perimeter Flashing	
B0115-3-15	Roof 3 Pt 16	Perimeter Flashing Tar	
B0115-4-1 Tar, Felt	Roof 4 Pt 13	Multi-layer Roofing	
B0115-4-2	Roof 4 Pt 13	Perolite	

B0115-4-3	Roof 4 Pt 13	Phenolic
B0115-4-4 Flashing, Shingle	Roof 4 Pt 14	Penetration Flashing
B0115-4-5 Tar, Felt	Roof 4 Pt 15	Multi-layer Roofing
B0115-4-6	Roof 4 Pt 15	Perelite
B0115-4-7	Roof 4 Pt 15	Poly ISO
B0115-5-1 Tar, Felt	Roof 5 Pt 16	Built up Roofing
B0115-5-2	Roof 5 Pt 16	Perelite
B0115-5-3	Roof 5 Pt 16	Phenolic
B0115-5-4	Roof 5 Pt 17	Penetration Flashing
B0115-5-5 Tar, Felt	Roof 5 Pt 18	Built up Roofing
B0115-5-6	Roof 5 Pt 18	Perelite
B0115-5-7	Roof 5 Pt 18	Phenolic
B0115-5-8	Roof 5 Pt 18	Poly ISO
B0115-6-1 Tar, Felt	Roof 6 Pt 19	Built up Roofing
B0115-6-2	Roof 6 Pt 19	Perelite
B0115-6-3	Roof 6-Pt 19	Phenolic
B0115-6-4	Roof 6 Pt 19	Poly ISO
B0115-6-5 Tar, Felt	Roof 6 Pt 20	Built up Roofing
B0115-6-6	Roof 6 Pt 20	Perelite
B0115-6-7	Roof 6 Pt 20	Phenolic
B0115-6-8	Roof 6 Pt 20	Poly ISO
B0115-6-9	Roof 6 Pt 21	Perimeter Flashing
B0115-6-10	Roof 6 Pt 22	Penetration
B0115-7-1 Tar, Felt	Roof 7 Pt 23	Built up Roofing
B0115-7-2	Roof 7 Pt 23	Perelite
B0115-7-3	Roof 7 Pt 23	Phenolic
B0115-7-4	Roof 7 Pt 23	Poly ISO
B0115-7-5 Tar, Felt	Roof 7 Pt 24	Built up Roofing
B0115-7-6	Roof 7 Pt 24	Perelite
B0115-7-8	Roof 7 Pt 24	Poly ISO
B0115-1-3	Roof 1 Pt 1	Multi layer Roofing

***\*Samples in italic and bold documented <1% asbestos. Further testing using TEM NOB method is recommended, if not further analyzed samples can be considered non-asbestos containing and can be discarded as construction debris. However, OSHA work practices and regulations apply.***

## **GENERAL STATEMENTS CONCERNING ASBESTOS INSPECTIONS IN BUILDINGS:**

This survey may not have evaluated internal linings or gaskets, if any exist. Before any work is scheduled on a boiler, which would affect these areas (i.e. demolition), samples of linings and gaskets should be analyzed for asbestos content.

This inspection does not represent that all ACM that may be present in or behind walls, ceilings, and floors have been discovered. Review all existing heating and plumbing plans before starting any demolition projects. Ensure that there is a contingency plan for asbestos found during demolitions. Unit prices should be included for any material that may be discovered.

Equipment that operates at high temperature such as kilns, muffle furnaces, flood and arc lights may be insulated with asbestos-containing materials such as block, panels, fabric, braid or gasket.

Cement pipes (roof drains, sewerage drains, etc.) may contain asbestos. Prior to any cutting, sanding, drilling or removal of these materials, bulk sample(s) should be collected and analyzed at an accredited laboratory.

The interior of fire doors may be filled with ACM as a fire retardant. Take the necessary precautions or have bulk samples analyzed before cutting, drilling or otherwise affecting the original integrity of the door.

Certain other materials including, but not limited to, paint, varnish, tape, ceramic tiles and cement have been known to contain asbestos; cutting, sanding, drilling or removal of these materials may release asbestos fibers.



## **APPENDIX A**

### **LABORATORY RESULTS**



# EMSL Analytical, Inc.

29 North Plains Highway, Unit # 4 Wallingford, CT 06492

Tel/Fax: (203) 284-5948 / (203) 284-5978

<http://www.EMSL.com> / [wallingfordlab@emsl.com](mailto:wallingfordlab@emsl.com)

EMSL Order: 241900696

Customer ID: AMCT50

Customer PO:

Project ID:

**Attention:** Jason Pringle  
AMC Environmental, LLC  
30 Hazel Terrace  
Suite 25  
Woodbridge, CT 06525

**Phone:** (203) 378-5020

**Fax:** (203) 375-7344

**Received Date:** 02/11/2019 8:00 AM

**Analysis Date:** 02/13/2019

**Collected Date:**

**Project:** STRATFORD ACADEMY- JOHNSON HOUSE

## Test Report: Asbestos Analysis of Bulk Materials via EPA 600/R-93/116 Method using Polarized Light Microscopy

Sample	Description	Appearance	Non-Asbestos		Asbestos
			% Fibrous	% Non-Fibrous	% Type
B0115-1-1-Insulation <small>241900696-0001</small>	Roof 1- pt. 1 - multi-layer roofing	Brown Fibrous Homogeneous	80% Cellulose	20% Non-fibrous (Other)	None Detected
B0115-1-1-Tar <small>241900696-0001A</small>	Roof 1- pt. 1 - multi-layer roofing	Black Non-Fibrous Homogeneous		100% Non-fibrous (Other)	None Detected
B0115-1-1-Felt <small>241900696-0001B</small>	Roof 1- pt. 1 - multi-layer roofing	Black Fibrous Homogeneous	80% Glass	20% Non-fibrous (Other)	None Detected
B0115-1-2-Insulation <small>241900696-0002</small>	Roof 1- pt. 1 - multi-layer roofing bottom layer	Brown Fibrous Homogeneous		100% Non-fibrous (Other)	None Detected
B0115-1-2-Tar <small>241900696-0002A</small>	Roof 1- pt. 1 - multi-layer roofing bottom layer	Black Non-Fibrous Homogeneous		100% Non-fibrous (Other)	None Detected
B0115-1-2-Felt <small>241900696-0002B</small>	Roof 1- pt. 1 - multi-layer roofing bottom layer	Black Fibrous Homogeneous	30% Glass	70% Non-fibrous (Other)	None Detected
B0115-1-4 <small>241900696-0003</small>	Roof 1- pt. 1 - perelite	Brown Fibrous Homogeneous	30% Cellulose	40% Perlite 30% Non-fibrous (Other)	None Detected
B0115-1-5 <small>241900696-0004</small>	Roof 1- pt. 1 - poly ISO insulation	Orange Non-Fibrous Homogeneous		50% Perlite 50% Non-fibrous (Other)	None Detected
B0115-1-6-Insulation <small>241900696-0005</small>	Roof 1- pt. 2 - multi-layer roofing	Brown Fibrous Homogeneous		40% Perlite 60% Non-fibrous (Other)	None Detected
B0115-1-6-Tar <small>241900696-0005A</small>	Roof 1- pt. 2 - multi-layer roofing	Black Non-Fibrous Homogeneous	2% Cellulose	98% Non-fibrous (Other)	None Detected
B0115-1-6-Felt <small>241900696-0005B</small>	Roof 1- pt. 2 - multi-layer roofing	Black Fibrous Homogeneous	80% Glass	20% Non-fibrous (Other)	None Detected
B0115-1-7 <small>241900696-0006</small>	Roof 1- pt. 2 - perelite	Brown Non-Fibrous Homogeneous	20% Cellulose	40% Perlite 40% Non-fibrous (Other)	None Detected
B0115-1-8 <small>241900696-0007</small>	Roof 1- pt. 2 - poly ISO insulation	Orange Fibrous Homogeneous	30% Glass	60% Perlite 10% Non-fibrous (Other)	None Detected
B0115-1-9-Flashing <small>241900696-0008</small> <i>Sample appears to be shingle.</i>	Roof 1- pt. 3 - perimeter flashing	Gray/Black Fibrous Homogeneous	15% Glass	5% Quartz 80% Non-fibrous (Other)	None Detected
B0115-1-9-Tar <small>241900696-0008A</small>	Roof 1- pt. 3 - perimeter flashing	Black Non-Fibrous Homogeneous		100% Non-fibrous (Other)	None Detected
B0115-2-1 <small>241900696-0009</small>	Roof 2- pt. 4 - multi-layer roofing	Black Fibrous Homogeneous	70% Glass	30% Non-fibrous (Other)	None Detected

Initial report from: 02/13/2019 13:42:10



# EMSL Analytical, Inc.

29 North Plains Highway, Unit # 4 Wallingford, CT 06492

Tel/Fax: (203) 284-5948 / (203) 284-5978

<http://www.EMSL.com> / [wallingfordlab@emsl.com](mailto:wallingfordlab@emsl.com)

**EMSL Order:** 241900696  
**Customer ID:** AMCT50  
**Customer PO:**  
**Project ID:**

## Test Report: Asbestos Analysis of Bulk Materials via EPA 600/R-93/116 Method using Polarized Light Microscopy

Sample	Description	Appearance	Non-Asbestos		Asbestos
			% Fibrous	% Non-Fibrous	% Type
B0115-2-2 <small>241900696-0010</small>	Roof 2- pt. 4 - perelite	Brown Fibrous Homogeneous	40% Cellulose	25% Perlite 35% Non-fibrous (Other)	None Detected
B0115-2-3 <small>241900696-0011</small>	Roof 2- pt. 4 - poly ISO	Yellow Non-Fibrous Homogeneous		100% Non-fibrous (Other)	None Detected
B0115-2-4-Tar <small>241900696-0012</small>	Roof 2- pt. 5 - multi-layer roofing	Black Non-Fibrous Homogeneous		100% Non-fibrous (Other)	None Detected
B0115-2-4-Felt <small>241900696-0012A</small>	Roof 2- pt. 5 - multi-layer roofing	Black Fibrous Homogeneous	70% Glass	30% Non-fibrous (Other)	None Detected
B0115-2-5 <small>241900696-0013</small>	Roof 2- pt. 5 - perelite	Brown Fibrous Homogeneous	65% Cellulose	10% Perlite 25% Non-fibrous (Other)	None Detected
B0115-2-6 <small>241900696-0014</small>	Roof 2- pt. 5 - poly ISO	Yellow Non-Fibrous Homogeneous		100% Non-fibrous (Other)	None Detected
B0115-2-7 <small>241900696-0015</small> <i>Sample appears to be shingle.</i>	Roof 2- pt. 6 - perimeter flashing	Black Non-Fibrous Homogeneous		100% Non-fibrous (Other)	None Detected
B0115-2-8 <small>241900696-0016</small>	Roof 2- pt. 6 - perimeter flashing tar	Black Non-Fibrous Homogeneous		100% Non-fibrous (Other)	None Detected
B0115-2-9-Tar <small>241900696-0017</small>	Roof 2- pt. 7 - multilayer roofing	Black Non-Fibrous Homogeneous		100% Non-fibrous (Other)	None Detected
B0115-2-9-Felt <small>241900696-0017A</small>	Roof 2- pt. 7 - multilayer roofing	Black Fibrous Homogeneous	25% Glass	75% Non-fibrous (Other)	None Detected
B0115-2-10 <small>241900696-0018</small>	Roof 2- pt. 7 - perelite (brown)	Brown Fibrous Homogeneous	25% Cellulose	15% Perlite 60% Non-fibrous (Other)	None Detected
B0115-2-11 <small>241900696-0019</small>	Roof 2- pt. 7 - Poly-ISO (yellow)	Yellow Non-Fibrous Homogeneous		100% Non-fibrous (Other)	None Detected
B0115-2-12 <small>241900696-0020</small> <i>Sample appears to be shingle.</i>	Roof 2- pt. 8 - penetration flashing	Black Fibrous Homogeneous	25% Glass	75% Non-fibrous (Other)	None Detected
B0115-3-1-Tar <small>241900696-0021</small>	Roof 3- pt. 9 - multi-layer roofing	Black Non-Fibrous Homogeneous		100% Non-fibrous (Other)	None Detected
B0115-3-1-Felt <small>241900696-0021A</small>	Roof 3- pt. 9 - multi-layer roofing	Black Fibrous Homogeneous	30% Glass	70% Non-fibrous (Other)	None Detected
B0115-3-2 <small>241900696-0022</small>	Roof 3- pt. 9 - perelite	Gray Fibrous Homogeneous	40% Cellulose 35% Min. Wool	15% Perlite 10% Non-fibrous (Other)	None Detected
B0115-3-3 <small>241900696-0023</small>	Roof 3- pt. 9 - phenolic	Brown Non-Fibrous Homogeneous		100% Non-fibrous (Other)	None Detected
B0115-3-4-Tar <small>241900696-0024</small>	Roof 3- pt.10 - multilayer roofing	Black Non-Fibrous Homogeneous		100% Non-fibrous (Other)	None Detected

Initial report from: 02/13/2019 13:42:10



# EMSL Analytical, Inc.

29 North Plains Highway, Unit # 4 Wallingford, CT 06492

Tel/Fax: (203) 284-5948 / (203) 284-5978

<http://www.EMSL.com> / [wallingfordlab@emsl.com](mailto:wallingfordlab@emsl.com)

**EMSL Order:** 241900696  
**Customer ID:** AMCT50  
**Customer PO:**  
**Project ID:**

## Test Report: Asbestos Analysis of Bulk Materials via EPA 600/R-93/116 Method using Polarized Light Microscopy

Sample	Description	Appearance	Non-Asbestos		Asbestos
			% Fibrous	% Non-Fibrous	% Type
B0115-3-4-Felt <small>241900696-0024A</small>	Roof 3- pt.10 - multilayer roofing	Black Fibrous Homogeneous	25% Glass	75% Non-fibrous (Other)	None Detected
B0115-3-5 <small>241900696-0025</small>	Roof 3- pt.10 - perolite	Brown Fibrous Homogeneous	45% Cellulose	20% Perlite 35% Non-fibrous (Other)	None Detected
B0115-3-6 <small>241900696-0026</small>	Roof 3- pt.10 - phenolic (red)	Brown Non-Fibrous Homogeneous		100% Non-fibrous (Other)	None Detected
B0115-3-7 <small>241900696-0027</small>	Roof 3- pt.10 - Poly ISO	Yellow Non-Fibrous Homogeneous		100% Non-fibrous (Other)	None Detected
B0115-3-8 <small>241900696-0028</small> <i>Sample appears to be shingle.</i>	Roof 3- pt.11 - perimeter flashing	Black Fibrous Homogeneous	15% Cellulose 20% Glass	5% Quartz 60% Non-fibrous (Other)	None Detected
B0115-3-9 <small>241900696-0029</small>	Roof 3- pt.11 - perolite	Brown Fibrous Homogeneous	70% Cellulose	15% Perlite 15% Non-fibrous (Other)	None Detected
B0115-3-10-Tar <small>241900696-0030</small>	Roof 3- pt.12 - multilayer roofing	Black Non-Fibrous Homogeneous		100% Non-fibrous (Other)	None Detected
B0115-3-10-Felt <small>241900696-0030A</small>	Roof 3- pt.12 - multilayer roofing	Black Fibrous Homogeneous	50% Glass	50% Non-fibrous (Other)	None Detected
B0115-3-11 <small>241900696-0031</small>	Roof 3- pt.12 - perolite (brown)	Brown Fibrous Homogeneous	70% Cellulose	15% Perlite 15% Non-fibrous (Other)	None Detected
B0115-3-12 <small>241900696-0032</small>	Roof 3- pt.12 - phenolic (red)	Rust Non-Fibrous Homogeneous		100% Non-fibrous (Other)	None Detected
B0115-3-13 <small>241900696-0033</small> <i>Sample appears to be felt.</i>	Roof 3- pt.12 - perolite (brown)	Brown/Black Non-Fibrous Homogeneous	35% Glass	65% Non-fibrous (Other)	None Detected
B0115-3-14 <small>241900696-0034</small> <i>Sample appears to be shingle.</i>	Roof 3- pt. 16 - perimeter flashing	Black Fibrous Homogeneous	15% Glass	5% Quartz 80% Non-fibrous (Other)	None Detected
B0115-3-15 <small>241900696-0035</small>	Roof 3- pt. 16 - perimeter flashing tar	Black Non-Fibrous Homogeneous		100% Non-fibrous (Other)	None Detected
B0115-4-1-Tar <small>241900696-0036</small>	Roof 4- pt. 13 - multi layer roofing	Black Non-Fibrous Homogeneous	5% Glass	95% Non-fibrous (Other)	None Detected
B0115-4-1-Felt <small>241900696-0036A</small>	Roof 4- pt. 13 - multi layer roofing	Black Fibrous Homogeneous	2% Cellulose 80% Glass	18% Non-fibrous (Other)	None Detected
B0115-4-2 <small>241900696-0037</small>	Roof 4- pt. 13 - perolite	Brown Fibrous Homogeneous	40% Cellulose	40% Perlite 20% Non-fibrous (Other)	None Detected
B0115-4-3 <small>241900696-0038</small>	Roof 4- pt. 13 - phenolic	Orange Non-Fibrous Homogeneous	5% Cellulose	60% Perlite 35% Non-fibrous (Other)	None Detected
B0115-4-4-Flashing <small>241900696-0039</small>	Roof 4- pt. 14 - penetration flashing	Black Non-Fibrous Homogeneous	4% Cellulose	96% Non-fibrous (Other)	None Detected

Initial report from: 02/13/2019 13:42:10



# EMSL Analytical, Inc.

29 North Plains Highway, Unit # 4 Wallingford, CT 06492

Tel/Fax: (203) 284-5948 / (203) 284-5978

<http://www.EMSL.com> / [wallingfordlab@emsl.com](mailto:wallingfordlab@emsl.com)

**EMSL Order:** 241900696  
**Customer ID:** AMCT50  
**Customer PO:**  
**Project ID:**

## Test Report: Asbestos Analysis of Bulk Materials via EPA 600/R-93/116 Method using Polarized Light Microscopy

Sample	Description	Appearance	Non-Asbestos		Asbestos
			% Fibrous	% Non-Fibrous	% Type
B0115-4-4-Shingle <small>241900696-0039A</small>	Roof 4- pt. 14 - penetration flashing	Gray/Black Non-Fibrous Homogeneous		10% Quartz 90% Non-fibrous (Other)	None Detected
B0115-4-5-Tar <small>241900696-0040</small>	Roof 4- pt. 15 - multi layer roofing	Black Non-Fibrous Homogeneous		100% Non-fibrous (Other)	None Detected
B0115-4-5-Felt <small>241900696-0040A</small>	Roof 4- pt. 15 - multi layer roofing	Black Fibrous Homogeneous	80% Glass	20% Non-fibrous (Other)	None Detected
B0115-4-6 <small>241900696-0041</small>	Roof 4- pt. 15 - perelite	Brown Fibrous Homogeneous	20% Cellulose	40% Perlite 40% Non-fibrous (Other)	None Detected
B0115-4-7 <small>241900696-0042</small>	Roof 4- pt. 15 - poly ISO	Yellow Non-Fibrous Homogeneous		100% Non-fibrous (Other)	None Detected
B0115-5-1-Tar <small>241900696-0043</small>	Roof 5- pt. 16 - built-up roofing	Black Non-Fibrous Homogeneous		100% Non-fibrous (Other)	None Detected
B0115-5-1-Felt <small>241900696-0043A</small>	Roof 5- pt. 16 - built-up roofing	Black Fibrous Homogeneous	85% Glass	15% Non-fibrous (Other)	None Detected
B0115-5-2 <small>241900696-0044</small>	Roof 5- pt. 16 - perelite	Brown Fibrous Homogeneous	40% Cellulose	45% Perlite 15% Non-fibrous (Other)	None Detected
B0115-5-3 <small>241900696-0045</small>	Roof 5- pt. 16 - phenolic	Orange Non-Fibrous Homogeneous	10% Cellulose	85% Perlite 5% Non-fibrous (Other)	None Detected
B0115-5-4 <small>241900696-0046</small> <i>Sample appears to be shingle.</i>	Roof 5- pt. 17 - penetration flashing	Gray/Black Non-Fibrous Homogeneous	10% Glass	10% Quartz 80% Non-fibrous (Other)	None Detected
B0115-5-5-Tar <small>241900696-0047</small>	Roof 5- pt. 18 - built-up roofing	Black Non-Fibrous Homogeneous	2% Cellulose	98% Non-fibrous (Other)	None Detected
B0115-5-5-Felt <small>241900696-0047A</small>	Roof 5- pt. 18 - built-up roofing	Black Fibrous Homogeneous	85% Glass	15% Non-fibrous (Other)	None Detected
B0115-5-6 <small>241900696-0048</small>	Roof 5- pt. 18 - perelite	Brown Fibrous Homogeneous	45% Cellulose	50% Perlite 5% Non-fibrous (Other)	None Detected
B0115-5-7 <small>241900696-0049</small>	Roof 5- pt. 18 - phenolic	Brown Non-Fibrous Homogeneous		80% Perlite 20% Non-fibrous (Other)	None Detected
B0115-5-8 <small>241900696-0050</small>	Roof 5- pt. 18 - poly ISO	Yellow Non-Fibrous Homogeneous		100% Non-fibrous (Other)	None Detected
B0115-6-1-Tar <small>241900696-0051</small>	Roof 6- pt. 19 - built-up roofing	Black Non-Fibrous Homogeneous		100% Non-fibrous (Other)	None Detected
B0115-6-1-Felt <small>241900696-0051A</small>	Roof 6- pt. 19 - built-up roofing	Black Fibrous Homogeneous	20% Glass	80% Non-fibrous (Other)	None Detected
B0115-6-2 <small>241900696-0052</small> <i>Sample appears to be perlite.</i>	Roof 6- pt. 19 - perelite	Brown Non-Fibrous Homogeneous	40% Cellulose	20% Perlite 40% Non-fibrous (Other)	None Detected

Initial report from: 02/13/2019 13:42:10



# EMSL Analytical, Inc.

29 North Plains Highway, Unit # 4 Wallingford, CT 06492

Tel/Fax: (203) 284-5948 / (203) 284-5978

<http://www.EMSL.com> / [wallingfordlab@emsl.com](mailto:wallingfordlab@emsl.com)

**EMSL Order:** 241900696  
**Customer ID:** AMCT50  
**Customer PO:**  
**Project ID:**

## Test Report: Asbestos Analysis of Bulk Materials via EPA 600/R-93/116 Method using Polarized Light Microscopy

Sample	Description	Appearance	Non-Asbestos		Asbestos
			% Fibrous	% Non-Fibrous	% Type
B0115-6-3 <small>241900696-0053</small>	Roof 6- pt. 19 - phenolic	Orange Non-Fibrous Homogeneous		80% Perlite 20% Non-fibrous (Other)	None Detected
B0115-6-4 <small>241900696-0054</small>	Roof 6- pt. 19 - poly ISO	Orange Non-Fibrous Homogeneous		40% Perlite 60% Non-fibrous (Other)	None Detected
B0115-6-5-Tar <small>241900696-0055</small>	Roof 6- pt. 20 - built-up roofing	Black Non-Fibrous Homogeneous		100% Non-fibrous (Other)	None Detected
B0115-6-5-Felt <small>241900696-0055A</small>	Roof 6- pt. 20 - built-up roofing	Black Fibrous Homogeneous	85% Glass	15% Non-fibrous (Other)	None Detected
B0115-6-6 <small>241900696-0056</small>	Roof 6- pt. 20 - perelite	Brown Fibrous Homogeneous	40% Cellulose	40% Perlite 20% Non-fibrous (Other)	None Detected
B0115-6-7 <small>241900696-0057</small>	Roof 6- pt. 20 - phenolic	Yellow Non-Fibrous Homogeneous		100% Non-fibrous (Other)	None Detected
B0115-6-8 <small>241900696-0058</small>	Roof 6- pt. 20 - poly ISO	Orange Non-Fibrous Homogeneous		60% Perlite 40% Non-fibrous (Other)	None Detected
B0115-6-9 <small>241900696-0059</small>	Roof 6- pt. 21 - perimeter flashing	Black Non-Fibrous Homogeneous	40% Cellulose 20% Glass	5% Quartz 35% Non-fibrous (Other)	None Detected
B0115-6-10 <small>241900696-0060</small>	Roof 6- pt. 22 - penetration	Black Fibrous Homogeneous	35% Cellulose 15% Glass	5% Quartz 45% Non-fibrous (Other)	None Detected
B0115-7-1-Tar <small>241900696-0061</small>	Roof 7- pt. 23 - built-up roofing	Black Non-Fibrous Homogeneous		100% Non-fibrous (Other)	None Detected
B0115-7-1-Felt <small>241900696-0061A</small>	Roof 7- pt. 23 - built-up roofing	Black Fibrous Homogeneous	30% Glass	70% Non-fibrous (Other)	None Detected
B0115-7-2 <small>241900696-0062</small>	Roof 7- pt. 23 - perelite	Brown Non-Fibrous Homogeneous	40% Cellulose	20% Perlite 40% Non-fibrous (Other)	None Detected
B0115-7-3 <small>241900696-0063</small>	Roof 7- pt. 23 - phenolic	Orange Non-Fibrous Homogeneous		80% Perlite 20% Non-fibrous (Other)	None Detected
B0115-7-4 <small>241900696-0064</small>	Roof 7- pt. 23 - poly ISO	Yellow Non-Fibrous Homogeneous		100% Non-fibrous (Other)	None Detected
B0115-7-5-Tar <small>241900696-0065</small>	Roof 7- pt. 24 - built-up roofing	Black Non-Fibrous Homogeneous		100% Non-fibrous (Other)	None Detected
B0115-7-5-Felt <small>241900696-0065A</small>	Roof 7- pt. 24 - built-up roofing	Black Fibrous Homogeneous	85% Glass	15% Non-fibrous (Other)	None Detected
B0115-7-6 <small>241900696-0066</small>	Roof 7- pt. 24 - perelite	Brown Non-Fibrous Homogeneous	40% Cellulose	40% Perlite 20% Non-fibrous (Other)	None Detected
B0115-7-7 <small>241900696-0067</small>	Roof 7- pt. 24 - phenolic	Orange Non-Fibrous Homogeneous		80% Perlite 20% Non-fibrous (Other)	None Detected
B0115-7-8 <small>241900696-0068</small>	Roof 7- pt. 24 - poly ISO	Yellow Non-Fibrous Homogeneous		100% Non-fibrous (Other)	None Detected

Initial report from: 02/13/2019 13:42:10



# EMSL Analytical, Inc.

29 North Plains Highway, Unit # 4 Wallingford, CT 06492

Tel/Fax: (203) 284-5948 / (203) 284-5978

<http://www.EMSL.com> / [wallingfordlab@emsl.com](mailto:wallingfordlab@emsl.com)

**EMSL Order:** 241900696  
**Customer ID:** AMCT50  
**Customer PO:**  
**Project ID:**

## Test Report: Asbestos Analysis of Bulk Materials via EPA 600/R-93/116 Method using Polarized Light Microscopy

Sample	Description	Appearance	Non-Asbestos		Asbestos
			% Fibrous	% Non-Fibrous	% Type
B0115-1-3	Roof 1- pt. 1 - multi-layer roofing	Brown Fibrous	35% Cellulose 25% Glass	40% Non-fibrous (Other)	None Detected
241900696-0069		Homogeneous			

Analyst(s) \_\_\_\_\_

Almedina Hodzic (52)

Kelsey Witik (17)

Quetcy Castro Romero (21)

Almedina Hodzic, Asbestos Laboratory Manager  
or Other Approved Signatory

EMSL maintains liability limited to cost of analysis. The above analyses were performed in general compliance with Appendix E to Subpart E of 40 CFR (previously EPA 600/M4-82-020 "Interim Method"), but augmented with procedures outlined in the 1993 ("final") version of the method. This report relates only to the samples reported above, and may not be reproduced, except in full, without written approval by EMSL. EMSL bears no responsibility for sample collection activities or analytical method limitations. Interpretation and use of test results are the responsibility of the client. All samples received in acceptable condition unless otherwise noted. This report must not be used by the client to claim product certification, approval, or endorsement by NVLAP, NIST or any agency of the federal government. EMSL recommends gravimetric reduction for all non-friable organically bound materials prior to analysis. Estimation of uncertainty is available on request.

Samples analyzed by EMSL Analytical, Inc. Wallingford, CT NVLAP Lab Code 200700-0,

Initial report from: 02/13/2019 13:42:10

**APPENDIX B**  
**ACCREDITATIONS**



**STATE OF CONNECTICUT**  
**DEPARTMENT OF PUBLIC HEALTH**

PURSUANT TO THE PROVISIONS OF THE GENERAL STATUTES OF CONNECTICUT

THE INDIVIDUAL NAMED BELOW IS CERTIFIED  
BY THIS DEPARTMENT AS A

**ASBESTOS CONSULTANT-INSP/MGMT PLANNER**

JASON P. PRINGLE

CERTIFICATE NO.  
**000269**

CURRENT THROUGH  
**09/30/19**

VALIDATION NO.  
**03-727299**

  
SIGNATURE

  
COMMISSIONER

**STATE OF CONNECTICUT**  
**DEPARTMENT OF PUBLIC HEALTH**

PURSUANT TO THE PROVISIONS OF THE GENERAL STATUTES OF CONNECTICUT

THE INDIVIDUAL NAMED BELOW IS CERTIFIED  
BY THIS DEPARTMENT AS A

**ASBESTOS CONSULTANT-INSP/MGMT PLANNER**

JASON P. PRINGLE

CERTIFICATE NO.  
**000269**

CURRENT THROUGH  
**09/30/19**

VALIDATION NO.  
**03-727299**

  
SIGNATURE

  
COMMISSIONER

## SECTION 01009

### MILESTONE SCHEDULE

#### PART 1 – GENERAL

##### 1.01 MASTER SCHEDULE

The following milestone schedule serves as a basis for bidding. A Master Schedule shall be developed at a general meeting of the successful bidder within fourteen (14) days of Letter of Intent to Award the Contracts. This Master Schedule will incorporate the milestones listed below.

##### 1.02 Milestone Dates:

- |    |                                  |                           |
|----|----------------------------------|---------------------------|
| A. | Issue for Bid:                   | <b>June 4, 2019</b>       |
| B. | Bid Opening:                     | <b>June 18, 2019</b>      |
| C. | Award Project – on or about:     | <b>June 21, 2019</b>      |
| D. | Start Construction/Mobilization: | <b>June 24, 2019</b>      |
| E. | Submittals & Shop Drawings:      | <b>June 26, 2019</b>      |
| F. | Substantial Completion:          | <b>August 16, 2019</b>    |
| G. | Final Close-out of Contract:     | <b>September 30, 2019</b> |

- Final Milestone Schedule to be coordinated and approved by the Town of Stratford and Stratford Public Schools
- Final close out of all contracts shall be by or prior to the date established above. All work including, but not limited to punch lists, project closeout, testing, balancing, owners operation, warranties, etc. shall be complete.

**END OF MILESTONE SCHEDULE**

#### Milestone Schedule



## SECTION 011000

### SUMMARY

#### PART 1 - GENERAL

##### 1.1 RELATED DOCUMENTS

- A. Drawings and general provisions of the Contract, including the Agreement and other Division 1 Specification Sections, apply to this Section.

##### 1.2 SUMMARY

- A. This Section includes the following:
  - 1. Work covered by the Contract Documents.
  - 2. Type of the Contract.
  - 3. Use of premises.
  - 4. Owner's occupancy requirements.
  - 5. Work restrictions.
  - 6. Specification formats and conventions.

##### 1.3 WORK COVERED BY CONTRACT DOCUMENTS

Project Identification:

**Roof Replacement:  
Stratford Academy – Johnson House  
719 Birdeye Street  
Stratford, CT 06615**

- A. Owner: The Town of Stratford
  - 1. Owner's Representative: Maurice McCarthy, Director of Public Works, (203) 385-4083
- B. Architect: Brian Snyder, Snyder Architects – (203) 203-243-3346
- C. The Work consists of the following:
  - 1. The Work includes but not limited to:
    - a. Removal of all existing roofing materials down to roof deck.
    - b. Installation of new thermoplastic roofing system.

#### 1.4 TYPE OF CONTRACT

- A. Project will be constructed under a single prime contract. Contractor to be referred to as “General Work Contractor” or “GC” or “Contractor”.

#### 1.5 USE OF PREMISES

- A. General: Contractor shall have limited use of premises for construction operations as required to perform work per Contract Documents. Contractor will coordinate access to project site with owner representative.

#### 1.6 WORK RESTRICTIONS

- A. On-Site Work Hours shall be coordinated with the Town of Stratford Department of Public Works and Stratford Public Schools.**

#### 1.7 SPECIFICATION FORMATS AND CONVENTIONS

- A. Specification Format: The Specifications are organized into Divisions and Sections using the 16-division format and CSI/CSC's "MasterFormat" numbering system.
1. Section Identification: The Specifications use Section numbers and titles to help cross-referencing in the Contract Documents. Sections in the Project Manual are in numeric sequence; however, the sequence is incomplete because all available Section numbers are not used. Consult the table of contents at the beginning of the Project Manual to determine numbers and names of Sections in the Contract Documents.
  2. Division 1: Sections in Division 1 govern the execution of the Work of all Sections in the Specifications.
- B. Specification Content: The Specifications use certain conventions for the style of language and the intended meaning of certain terms, words, and phrases when used in particular situations. These conventions are as follows:
1. Abbreviated Language: Language used in the Specifications and other Contract Documents is abbreviated. Words and meanings shall be interpreted as appropriate. Words implied, but not stated, shall be inferred as the sense requires. Singular words shall be interpreted as plural, and plural words shall be interpreted as singular where applicable as the context of the Contract Documents indicates.
  2. Imperative mood and streamlined language are generally used in the Specifications. Requirements expressed in the imperative mood are to be performed by Contractor. Occasionally, the indicative or subjunctive mood

may be used in the Section Text for clarity to describe responsibilities that must be fulfilled indirectly by Contractor or by others when so noted.

- a. The words "shall," "shall be," or "shall comply with," depending on the context, are implied where a colon (:) is used within a sentence or phrase.

## **PART 2 - PRODUCTS**

- **Contractor agrees to order long lead materials, submit submittals and shop drawings within 5 days of being awarded contract. "Or-equal" long lead materials will be considered during the bidding period (use attached substitution form).**

## **PART 3 - EXECUTION (Not Used)**

END OF SECTION 01100





**SECTION 01250****REGULATORY REQUIREMENTS****PART 1.00 - GENERAL****1.01 RELATED DOCUMENTS**

- A. The General Contract Provisions and the General Requirements of Division 1 apply to the work of this Section.

**1.02 LAWS, CODES, ORDINANCES, PERMITS, FEES, ETC.**

- A. All necessary permits from the municipal or other public authorities shall be secured by the Contractor who shall give all notices required by Law, Municipal Ordinances, or the Rules and Regulations of the various Municipal Bureaus or Departments, and also as a part of the Contract, shall comply with all Federal and State laws and all Municipal Ordinances or Regulations that may be applicable to this work which shall be issued (in compliance with Ordinances or Regulations existing at the time of Notice to Proceed) by any or all of said Departments as applying to the work of the Contract.
- B. Wherever in these Specifications the name of an Official, Bureau or Department is mentioned, it is intended to mean that Official, Bureau, or Department having jurisdiction.
- C. The Contractor shall deliver to the Owner all permits or certificates of approval and inspections issued by all Agencies having jurisdiction in connection with this work, before the certificate for final payment is issued.
- D. Laws, Codes, Provisions - Comply with:
1. Connecticut Building Code
  2. NFPA 101
  3. OSHA
  4. See other codes and ordinances referenced therein.
  5. In case of conflicting requirements between the various codes, the Contract Documents or any other Local and State Codes or Ordinances having jurisdiction, the most stringent shall govern.

3/8/2019

- E. It is the intention of these Contract documents that the contractor's work be fully in compliance with all applicable codes and ordinances and that the cost of such compliance is included in the Contract Price. If there are errors or omissions in the contract documents which would result in work that was not in compliance with all the applicable codes and ordinances then the contractor shall not proceed but shall notify the architect in writing. The Contractor shall have included in the contract price the cost of all such work even in the case of errors or omissions to the contract documents if such errors and omissions could have been readily ascertainable through the exercise of reasonable diligence by the contractors.

**END OF SECTION 01250**

## SECTION 01310

### PROJECT MANAGEMENT AND COORDINATION

#### **PART 1.00 - GENERAL**

##### 1.01 GENERAL REQUIREMENTS

- A. Work of this Section, as shown or specified, shall be in accordance with the requirements of the Contract Documents.

##### 1.02 WORK INCLUDED

- A. To enable orderly review of progress during construction and to provide for systematic discussions of problems, the Architect will conduct project meetings throughout the construction period.
- B. In general, project meetings will be held bi-weekly at the job site in accordance with a mutually acceptable schedule.
- C. The purpose of the project meetings is analysis of problems that might arise between the Owner and the Contractor relative to execution of the work.

##### 1.03 RELATED WORK

- A. The Contractor's relations with his subcontractors and materials suppliers, and discussions relative thereto, are the Contractor's responsibility as described in the General Conditions and are not part of project meetings content.

##### 1.04 QUALITY ASSURANCE

- A. Persons designated by the Contractor to attend and participate in project meetings shall have all required authority to commit the Contractor to solutions as agreed upon in the project meetings.

##### 1.05 SUBMITTALS

- A. Agenda Items: To the maximum extent possible, advise the Architect at least 24 hours in advance of the project meeting regarding all items to be added to the agenda.

### **PROJECT MANAGEMENT AND COORDINATION**

- B. Minimum Agenda:
1. Review work progress since last meeting.
  2. Note field observations, problems and decisions.
  3. Identify problems which impede planned progress.
  4. Review off-site fabrication problems.
  5. Develop corrective measures and procedures to regain schedule.
  6. Coordinate projected progress with other prime contractors.
  7. Review submittal schedules, expedite as required to maintain schedule.
- C. Minutes:  
The Contractor will compile minutes of each project meeting and will distribute copies to the Owner and the Architect. The Contractor shall make and distribute such other copies as he wishes.

## **PART 2.00 - PRODUCTS**

(Not Used)

## **PART 3.00 - EXECUTION**

### **3.01 MEETING SCHEDULE**

- A. There will be a Pre-construction meeting shortly after award of contract to review schedule, use of site, and team coordination issues.
- B. Coordinate with the Architect as required to establish a mutually acceptable schedule for project meetings.

### **3.02 MEETING LOCATION**

- A. To the maximum extent practicable, project meetings shall be held at the job site. Provide adequate space and facility including table, chairs, and lighting for proper conduct of meetings.

### **3.03 ATTENDANCE**

- A. To the maximum extent practicable, assign the same person or persons to represent the Contractor at project meetings throughout the construction period. Subcontractors, materials suppliers, and others may be invited to attend those project meetings in which their aspects of the work are involved.

**END OF SECTION 01202**

## **PROJECT MANAGEMENT AND COORDINATION**

**SECTION 01330****SUBMITTALS****PART 1.00 - GENERAL****1.01 GENERAL REQUIREMENTS**

- A. Work of this Section, as shown or specified, shall be in accordance with the requirements of the Contract Documents.

**1.02 WORK INCLUDED**

- A. Work of this Section includes all labor, materials, equipment, and services necessary to complete submittal requirements as specified herein, including, but not limited to, the following:
  - 1. Construction schedules.
  - 2. Survey data.
  - 3. Shop drawings and samples.
  - 4. Manuals.
  - 5. Integrated drawings.

**1.03 RELATED WORK**

- A. Substitution requirements - Section 01600.
- B. General submittal requirements - General Conditions.

**PART 2.00 - PRODUCTS****2.01 CONSTRUCTION SCHEDULES**

- A. Refer to the *Agreement* for submission of a progress schedule.
- B. Contractor shall submit a Schedule of Submittals within thirty (14) days of award of contract.

## 2.02 SHOP DRAWINGS AND SAMPLES

### A. General:

1. Samples, shop drawings, manufacturer's literature, and other required information shall be submitted in sufficient time to permit proper consideration and action on same before any materials and items are delivered on the work. All samples of materials requiring laboratory tests shall be submitted to the laboratory for testing in sufficient time to obtain test results before such materials are required to be used in the work.
2. Shop drawings for each Section of the work shall be numbered consecutively, and the numbering system shall be retained throughout all revisions. Each drawing shall have a clear space for the stamps of the Contractor, Architect, and one of the Architect's consultants.
3. No work shall be fabricated, manufactured, or installed from shop drawings stamped "Revise and Resubmit" or "Rejected", and such shop drawings shall be corrected and resubmitted by the Contractor until accepted by the Architect. At least one complete set of "No Exceptions Taken" or "Exceptions Taken As Noted" shop drawings shall be kept at the site in the Contractor's field office for reference at all times. "Revise and Resubmit" or "Rejected" shop drawings shall not be permitted at the site.
4. Submittals marked "No Exceptions Taken":
  - a. Submittals which require no corrections by the Architect will be marked "No Exceptions Taken".
5. Submittals marked "Exception Taken as Noted":
  - a. Submittals which require only a minor amount of correcting shall be marked "Exceptions Taken as Noted". This mark shall mean that checking is complete and all corrections are obvious without ambiguity. Fabrication will be allowed on work "Exceptions Taken as Noted", provided such action will expedite construction and noted corrections are adhered to. If fabrication is not made strictly in accordance with corrections noted, the item shall be rejected in the field, and the Contractor will be required to replace such work in accordance with corrected submittals.

6. Submittals marked "Revise and Resubmit" or "Rejected":
  - a. When submittals are contrary to contract requirements or too many corrections are required, they shall be marked "Revise and Resubmit" or "Rejected". No work shall be fabricated under this mark. The Architect shall list his reasons for rejection on the submittals or in the transmittal letter accompanying their return. The submittals must be corrected and resubmitted for approval.
  
7. All shop drawings and samples shall be identified as follows:
  - a. Date of submittal.
  - b. Title of project.
  - c. Name of Contractor and date of his approval.
  - d. Name of subcontractor or supplier and date of submittal to Contractor.
  - e. Number of submission.
  - f. Any qualification, departure, or deviation from the requirements of the Contract.
  - g. Federal Specification or ASTM number where required.
  - h. Such additional information as may be required by the Specifications for the particular material being furnished.
  
8. The Architect will review and approve shop drawings and samples for approval with reasonable promptness, but only for conformance with the design concept of the work and with information contained in the Contract Documents.
  
9. The Contractor shall submit appropriate transmittal forms with every submittal of shop drawings, manufacturer's literature, and samples. All sepia reproduces shall be rolled on cardboard tubes for resubmittal. The Contractor shall submit all required shop drawings, manufacturer's literature and samples in accordance with the following procedures noted herein.

10. Unless otherwise specifically directed by the Architect, make all shop drawings accurately to a scale sufficiently large to show all pertinent features of the item and its method of connection to the work.
11. The Contractor shall submit one copy of each standard referred to in the Specifications (ASTM, Fed. Spec., etc.) with the submission of each respective shop drawing, sample, or literature.

**B. Submission of Shop Drawings:**

1. **Architectural Work:** Submit one (1) sepia reproducible and two (2) black line prints of each shop drawing to the Architect for approval. If approved, the Architect will return one (1) sepia stamped "No Exceptions Taken" or "Exceptions Taken as Noted", and the Contractor shall print the required number of copies. In the event the Architect returns one (1) sepia stamped "Revise and Resubmit" or "Rejected", the Contractor shall make indicated changes and resubmit one (1) sepia reproducible and two (2) black line prints to the Architect.
2. **Structural Work and Mechanical Work:** Submit one (1) sepia reproducible and two (2) black line prints of each shop drawing to the Engineer, with one (1) black line print and copy of the transmittal form to the Architect. If accepted, the Architect shall return one (1) sepia stamped "No Exceptions Taken" or "Exceptions Taken as Noted", and the Contractor shall print the required number of copies. In the event the Architect returns one (1) sepia stamped "Revise and Resubmit" or "Rejected", the Contractor shall make indicated changes and resubmit one (1) sepia reproducible and two (2) black line prints to the Engineer, with a copy of the transmittal form and one (1) black line print to the Architect.
3. **Prints:** The Contractor shall provide all prints of shop drawings as reasonably required by subcontractors, material suppliers, superintendents, inspectors, and others as required for the work, or as directed by the Architect. The Contractor shall pay all costs in connection with printing and distribution of shop drawings.

**C. Submission of Manufacturer's Literature, Including Catalog, Catalog Cuts, Brochures, Charts, Test Data, and Similar Information:**

1. Manufacturers literature will receive consideration only when accompanied by the transmittal form properly filled out, as the Specification Section and paragraph numbers describing such materials. Any deviations from contract requirements shall be stated on the above form or attached to it.



2. Architectural Work: Submit six (6) copies of manufacturer's literature to the Architect for acceptance. If accepted, the Architect will return four (4) copies stamped "No Exceptions Taken" or "Exceptions Taken as Noted". In the event the Architect returns the literature stamped "Revise and Resubmit" or "Rejected", he will return two (2) copies only. The Contractor shall resubmit six (6) copies of correct or corrected literature of all submissions stamped "Revise and Resubmit" or "Rejected", with one (1) copy of correct or corrected literature with copy of the transmittal form to the Architect.
- ~~3. Structural Work and Mechanical Work: Submit six (6) copies of manufacturer's literature to the Engineer, with one (1) copy of the literature and copy of the transmittal form to the Architect. If accepted, the Architect will return four (4) copies stamped "No Exceptions Taken" or "Exceptions Taken as Noted". In the event the Architect stamps the literature "Revise and Resubmit" or "Rejected", he will return two (2) copies only. The Contractor shall resubmit six (6) copies of correct or corrected literature to the Engineer for all submissions stamped "Revised and Resubmit" or "Rejected", with one (1) copy of correct or corrected literature with copy of the transmittal form to the Architect.~~
4. All copies of manufacturer's literature required to be resubmitted hereunder shall be original printed material. Reproductions of printed material will not receive consideration.

D. Submissions of Samples:

1. All samples shall be submitted in triplicate unless otherwise indicated in the Specifications.
2. Samples will receive consideration only when accompanied by the transmittal form properly filled out, as indicated, and listing each sample, as well as the listing of any ASTM, Federal or other standard references specified or applicable and such additional information as may be required by the Specifications for the materials being submitted. Any deviation from the contract requirements shall be so stated on the above form or attached to it.
3. The Architect shall have the right to require submission of samples of any materials, whether or not specifically indicated in the various Sections of the Specifications.

4. Unless otherwise specified, samples of sufficient size to indicate general visual effect shall be submitted. Where samples must show a range of color, texture, finish, graining, or other similar property, the Contractor shall submit sets or pairs illustrating the full scope of the range.
5. One (1) sample of each submission will be returned to the Contractor. Samples stamped "Revise and Resubmit" or "Rejected" by the Architect shall be resubmitted in triplicate by the Contractor.
6. All samples stamped "No Exceptions Taken" or "Exceptions Taken as Noted" shall be kept at the site in the Contractor's field office facilities for reference at all times. "Revise and Resubmit" or "Rejected" samples shall not be kept at the site.

## 2.03 MANUALS

- A. Where manuals are required to be submitted covering included in this work, prepare all such manuals in durable plastic binders approximately 8-1/2 x 11" in size and with at least the following:
  1. Identification on, or readable through, the front cover stating general nature of the manual.
  2. Neatly typewritten index near the front of the manual furnishing immediate information as to location in the manual of all emergency data regarding the installation.
  3. Complete instructions regarding operation and maintenance of all equipment involved.
  4. Complete nomenclature of all replaceable parts, their part numbers, current cost, and name and address of nearest vendor of parts.
  5. Copy of all guarantees and warranties issued.
  6. Copy of the approved shop drawings with all data concerning changes made during construction.
- B. Where contents of manuals include manufacturer's catalog pages, clearly indicate the precise items included in this installation and delete or otherwise clearly indicate all manufacturer's data with which this installation is not concerned.
- C. Number of Copies Required: Refer to Section 01770 - Contract Closeout.

## 2.04 INTEGRATED DRAWINGS

- A. ~~The HVAC subcontractor shall prepare a Drawing or Drawings showing duct work, heating and sprinkler piping. This Drawing shall include location of grilles, registers, etc., and access doors in hung ceilings. Locations shall be fixed by elevations and dimensions from column center lines and/or walls.~~
- B. ~~The HVAC subcontractor shall prepare and distribute to the Plumbing and Electrical subcontractors, the General Contractor, the Construction Manager, and to the Architect a sepia of the above.~~
- C. ~~The HVAC subcontractor shall lay out on his sepia the reflected ceiling plan, beam soffit elevations, ceiling heights, roof openings, etc.~~
- D. ~~The Plumbing subcontractor shall lay out on his sepia the piping, valves, cleanouts, etc., indicating locations and elevations and shall indicate the necessary access doors.~~
- E. ~~The Electrical subcontractor shall indicate on his sepia the fixtures, large conduit runs, clearances, pull boxes, junction boxes, sound system speakers, etc.~~
- F. ~~The General Contractor shall indicate on his sepia any structural framing, ceiling hangers, etc.~~
- G. The General Contractor shall call as many meetings with the subcontractors as are necessary to resolve any conflicts that become apparent. He will call on the services of the ~~Consultant Engineer or~~ Architect where necessary. Any conflicts which result in a relocation of a finished surface are to be brought to the attention of the Architect prior to installation.
- H. ~~On resolution of the conflicts, each subcontractor shall enter his own work on the HVAC subcontractor's sepia, which shall become the master or integrated Drawing. The master sepia shall be signed by each contributing subcontractor to indicate his acceptance of the arrangement of the work.~~
- I. ~~A reproducible copy of the master integrated Drawing will be prepared by the HVAC subcontractor. The Construction Manager will make distribution to the contractors and the Architect.~~
- J. Each subcontractor shall prepare his shop Drawings in accordance with the integrated Drawings. No work will be permitted without approved shop Drawings. It is therefore essential that this procedure be instituted as quickly as possible.

## 2.05 SURVEY DATA

- A. Be responsible for properly laying out the work and for the lines and measurements for the work executed under the Contract Documents. Verify the figures shown on the Drawings before laying out the work.
- B. Be responsible for the proper location and level of the work and for maintenance of the reference lines and bench marks. Establish bench marks and axis lines at each floor showing partition layout lines and dimensional reference points as required for the information and guidance of all trades.
- C. The mechanical and electrical trades shall be responsible for the layout of the duct work, piping, and conduit based on the reference lines and bench marks established.

## **PART 3.00 - EXECUTION**

### 3.01 COORDINATION OF SUBMITTALS

- A. Prior to submittal for Architect's review, use all means necessary to fully coordinate all material, including the following procedures:
  - 1. Determine and verify all field dimensions and conditions, materials, catalog numbers and similar data.
  - 2. Coordinate as required with all trades and with public agencies involved.
  - 3. Secure all necessary approvals from public agencies and others and signify by stamp, or other means, that they have been secured.
  - 4. Clearly indicate all deviations from the Contract Documents.
- B. Unless otherwise specifically permitted by the Architect, make all submittals in groups containing all associated items; the Architect may reject partial submittals as not complying with the provisions of the Contract Documents.

**END OF SECTION 01300**

**SECTION 01400****QUALITY REQUIREMENTS****PART 1 - GENERAL****1.1 RELATED DOCUMENTS**

- A. Drawings and general provisions of the Contract, and other Division 1 Specification Sections, apply to this Section.

**1.2 SUMMARY**

- A. This Section includes administrative and procedural requirements for quality-control services.
- B. Quality-control services include inspections, tests, and related actions, including reports performed by Contractor, by independent agencies, and by governing authorities. They do not include contract enforcement activities performed by Architect.
- C. Inspection and testing services are required to verify compliance with requirements specified or indicated. These services do not relieve Contractor of responsibility for compliance with Contract Document requirements.
- D. Requirements of this Section relate to customized fabrication and installation procedures, not production of standard products.
  - 1. Specific quality-control requirements for individual construction activities are specified in the Sections that specify those activities. Requirements in those Sections may also cover production of standard products.
  - 2. Specified inspections, tests, and related actions do not limit Contractor's quality-control procedures that facilitate compliance with Contract Document requirements.
  - 3. Requirements for Contractor to provide quality-control services required by Architect, Owner, or authorities having jurisdiction are not limited by provisions of this Section.
- E. Related Sections: The following Sections contain requirements that relate to this Section:
  - 1. Division 1 Section "Submittals" specifies requirements for development of a schedule of required tests and inspections.

### 1.3 RESPONSIBILITIES

- A. Contractor Responsibilities: Unless otherwise indicated as the responsibility of another identified entity, Contractor shall provide inspections, tests, and other quality-control services specified elsewhere in the Contract Documents and required by authorities having jurisdiction. Costs for these services are included in the Contract Sum.
1. Where individual Sections specifically indicate that certain inspections, tests, and other quality-control services are the Contractor's responsibility, the Contractor shall employ and pay a qualified independent testing agency to perform quality-control services. Costs for these services are included in the Contract Sum.
  2. Where individual Sections specifically indicate that certain inspections, tests, and other quality-control services are the Owner's responsibility, the Owner will employ and pay a qualified independent testing agency to perform those services.
- B. Retesting: The Contractor is responsible for retesting where results of inspections, tests, or other quality-control services prove unsatisfactory and indicate noncompliance with Contract Document requirements, regardless of whether the original test was Contractor's responsibility.
1. The cost of retesting construction, revised or replaced by the Contractor, is the Contractor's responsibility where required tests performed on original construction indicated noncompliance with Contract Document requirements.
- C. Associated Services: Cooperate with agencies performing required inspections, tests, and similar services, and provide reasonable auxiliary services as requested. Notify the agency sufficiently in advance of operations to permit assignment of personnel. Auxiliary services required include, but are not limited to, the following:
1. Provide access to the Work.
  2. Furnish incidental labor and facilities necessary to facilitate inspections and tests.
  3. Take adequate quantities of representative samples of materials that require testing or assist the agency in taking samples.
  4. Provide facilities for storage and curing of test samples.
  5. Deliver samples to testing laboratories.
  6. Provide the agency with a preliminary design mix proposed for use for materials mixes that require control by the testing agency.
  7. Provide security and protection of samples and test equipment at the Project Site.
- D. Duties of the Testing Agency: The independent agency engaged to perform inspections, sampling, and testing of materials and construction specified in

individual Sections shall cooperate with the Architect and the Contractor in performance of the agency's duties. The testing agency shall provide qualified personnel to perform required inspections and tests.

1. The agency shall notify the Architect and the Contractor promptly of irregularities or deficiencies observed in the Work during performance of its services.
2. The agency is not authorized to release, revoke, alter, or enlarge requirements of the Contract Documents or approve or accept any portion of the Work.
3. The agency shall not perform any duties of the Contractor.

E. Coordination: Coordinate the sequence of activities to accommodate required services with a minimum of delay. Coordinate activities to avoid the necessity of removing and replacing construction to accommodate inspections and tests.

1. The Contractor is responsible for scheduling times for inspections, tests, taking samples, and similar activities.

#### 1.4 SUBMITTALS

A. Unless the Contractor is responsible for this service, the independent testing agency shall submit a certified written report, in duplicate, of each inspection, test, or similar service to the Architect. If the Contractor is responsible for the service, submit a certified written report, in duplicate, of each inspection, test, or similar service through the Contractor.

1. Submit additional copies of each written report directly to the governing authority, when the authority so directs.
2. Report Data: Written reports of each inspection, test, or similar service include, but are not limited to, the following:
  - a. Date of issue.
  - b. Project title and number.
  - c. Name, address, and telephone number of testing agency.
  - d. Dates and locations of samples and tests or inspections.
  - e. Names of individuals making the inspection or test.
  - f. Designation of the Work and test method.
  - g. Identification of product and Specification Section.
  - h. Complete inspection or test data.
  - i. Test results and an interpretation of test results.
  - j. Ambient conditions at the time of sample taking and testing.
  - k. Comments or professional opinion on whether inspected or tested Work complies with Contract Document requirements.
  - l. Name and signature of laboratory inspector.

- m. Recommendations on retesting.

## 1.5 QUALITY ASSURANCE

- A. Qualifications for Service Agencies: Engage inspection and testing service agencies, including independent testing laboratories, that are pre-qualified as complying with the American Council of Independent Laboratories' "Recommended Requirements for Independent Laboratory Qualification" and that specialize in the types of inspections and tests to be performed.
  - 1. Each independent inspection and testing agency engaged on the Project shall be authorized by authorities having jurisdiction to operate in the state where the Project is located.

## **PART 2 - PRODUCTS** (Not Applicable)

## **PART 3 - EXECUTION**

### 3.1 REPAIR AND PROTECTION

- A. General: Upon completion of inspection, testing, sample taking and similar services, repair damaged construction and restore substrates and finishes. Comply with Contract Document requirements for Division 1 Section "Cutting and Patching."
- B. Protect construction exposed by or for quality-control service activities, and protect repaired construction.
- C. Repair and protection is Contractor's responsibility, regardless of the assignment of responsibility for inspection, testing, or similar services.

**END OF SECTION 01400**



## SECTION 01600

### PRODUCT REQUIREMENTS

#### PART 1 - GENERAL

##### 1.1 RELATED DOCUMENTS

- A. Drawings and general provisions of the Contract, and other Division 1 Specification Sections, apply to this Section.

##### 1.2 SUMMARY

- A. This Section includes the following administrative and procedural requirements: selection of products for use in Project; product delivery, storage, and handling; manufacturers' standard warranties on products; special warranties; product substitutions; and comparable products.
- B. Related Sections include the following:
  - 1. Division 1 Section "Allowances" for products selected under an allowance.
  - 2. Division 1 Section "Alternates" for products selected under an alternate.
  - 3. Division 1 Section "Closeout Procedures" for submitting warranties for contract closeout.
  - 4. Divisions 2 through 16 Sections for specific requirements for warranties on products and installations specified to be warranted.

##### 1.3 DEFINITIONS

- A. Products: Items purchased for incorporating into the Work, whether purchased for Project or taken from previously purchased stock. The term "product" includes the terms "material," "equipment," "system," and terms of similar intent.
  - 1. Named Products: Items identified by manufacturer's product name, including make or model number or other designation, shown or listed in manufacturer's published product literature, that is current as of date of the Contract Documents.
  - 2. New Products: Items that have not previously been incorporated into another project or facility, except that products consisting of recycled-content materials are allowed, unless explicitly stated otherwise. Products salvaged or recycled from other projects are not considered new products.
  - 3. Comparable Product: Product that is demonstrated and approved through submittal process, or where indicated as a product substitution, to have the indicated qualities related to type, function, dimension, in-service

#### **PRODUCT REQUIREMENTS**

01600 - 1 of 10

performance, physical properties, appearance, and other characteristics that equal or exceed those of specified product.

- B. Substitutions: Changes in products, materials, equipment, and methods of construction from those required by the Contract Documents and proposed by Contractor.
- C. Basis-of-Design Product Specification: Where a specific manufacturer's product is named and accompanied by the words "basis of design," including make or model number or other designation, to establish the significant qualities related to type, function, dimension, in-service performance, physical properties, appearance, and other characteristics for purposes of evaluating comparable products of other named manufacturers.
- D. Manufacturer's Warranty: Preprinted written warranty published by individual manufacturer for a particular product and specifically endorsed by manufacturer to Owner.
- E. Special Warranty: Written warranty required by or incorporated into the Contract Documents, either to extend time limit provided by manufacturer's warranty or to provide more rights for Owner.

#### 1.4 SUBMITTALS

- A. Product List: Submit a list, in tabular form, showing specified products. Include generic names of products required. Include manufacturer's name and proprietary product names for each product.
  1. Coordinate product list with Contractor's Construction Schedule and the Submittals Schedule.
  2. Form: Tabulate information for each product under the following column headings:
    - a. Specification Section number and title.
    - b. Generic name used in the Contract Documents.
    - c. Proprietary name, model number, and similar designations.
    - d. Manufacturer's name and address.
    - e. Supplier's name and address.
    - f. Installer's name and address.
    - g. Projected delivery date or time span of delivery period.
    - h. Identification of items that require early submittal approval for scheduled delivery date.
  3. Completed List: Within 60 days after date of commencement of the Work, submit 3 copies of completed product list. Include a written explanation for omissions of data and for variations from Contract requirements.

4. Architect's Action: Architect will respond in writing to Contractor within 15 days of receipt of completed product list. Architect's response will include a list of unacceptable product selections and a brief explanation of reasons for this action. Architect's response, or lack of response, does not constitute a waiver of requirement that products comply with the Contract Documents.

**B. Substitution Requests: Submit three copies of each request for consideration no later than 5 business days prior to bid opening.** Identify product or fabrication or installation method to be replaced. Include Specification Section number and title and Drawing numbers and titles.

1. Substitution Request Form: Use form provided at end of Section.
2. Documentation: Show compliance with requirements for substitutions and the following, as applicable:
  - a. Statement indicating why specified material or product cannot be provided.
  - b. Coordination information, including a list of changes or modifications needed to other parts of the Work and to construction performed by Owner and separate contractors, that will be necessary to accommodate proposed substitution.
  - c. Detailed comparison of significant qualities of proposed substitution with those of the Work specified. Significant qualities may include attributes such as performance, weight, size, durability, visual effect, and specific features and requirements indicated.
  - d. Product Data, including drawings and descriptions of products and fabrication and installation procedures.
  - e. Samples, where applicable or requested.
  - f. List of similar installations for completed projects with project names and addresses and names and addresses of architects and owners.
  - g. Material test reports from a qualified testing agency indicating and interpreting test results for compliance with requirements indicated.
  - h. Research/evaluation reports evidencing compliance with building code in effect for Project, from a model code organization acceptable to authorities having jurisdiction.
  - i. Detailed comparison of Contractor's Construction Schedule using proposed substitution with products specified for the Work, including effect on the overall Contract Time. If specified product or method of construction cannot be provided within the Contract Time, include letter from manufacturer, on manufacturer's letterhead, stating lack of availability or delays in delivery.
  - j. Cost information, including a proposal of change, if any, in the Contract Sum.
  - k. Contractor's certification that proposed substitution complies with requirements in the Contract Documents and is appropriate for applications indicated.

#### PRODUCT REQUIREMENTS

01600 - 3 of 10

- I. Contractor's waiver of rights to additional payment or time that may subsequently become necessary because of failure of proposed substitution to produce indicated results.
- 3. Architect's Action: If necessary, Architect will request additional information or documentation for evaluation within one week of receipt of a request for substitution. Architect will notify Contractor of acceptance or rejection of proposed substitution within 15 days of receipt of request, or 7 days of receipt of additional information or documentation, whichever is later.
  - a. Form of Acceptance: Change Order.
  - b. Use product specified if Architect cannot make a decision on use of a proposed substitution within time allocated.
- C. Basis-of-Design Product Specification Submittal: Comply with requirements in Division 1 Section "Submittal Procedures." Show compliance with requirements.

## 1.5 QUALITY ASSURANCE

- A. Compatibility of Options: If Contractor is given option of selecting between two or more products for use on Project, product selected shall be compatible with products previously selected, even if previously selected products were also options.
  - 1. Each contractor is responsible for providing products and construction methods compatible with products and construction methods of other contractors.
  - 2. If a dispute arises between contractors over concurrently selectable but incompatible products, Architect will determine which products shall be used.

## 1.6 PRODUCT DELIVERY, STORAGE, AND HANDLING

- A. Deliver, store, and handle products using means and methods that will prevent damage, deterioration, and loss, including theft. Comply with manufacturer's written instructions.
  - 1. Schedule delivery to minimize long-term storage at Project site and to prevent overcrowding of construction spaces.
  - 2. Coordinate delivery with installation time to ensure minimum holding time for items that are flammable, hazardous, easily damaged, or sensitive to deterioration, theft, and other losses.
  - 3. Deliver products to Project site in an undamaged condition in manufacturer's original sealed container or other packaging system,

### **PRODUCT REQUIREMENTS**

01600 - 4 of 10

- complete with labels and instructions for handling, storing, unpacking, protecting, and installing.
4. Inspect products on delivery to ensure compliance with the Contract Documents and to ensure that products are undamaged and properly protected.
  5. Store products to allow for inspection and measurement of quantity or counting of units.
  6. Store materials in a manner that will not endanger Project structure.
  7. Store products that are subject to damage by the elements, under cover in a weathertight enclosure above ground, with ventilation adequate to prevent condensation.
  8. Comply with product manufacturer's written instructions for temperature, humidity, ventilation, and weather-protection requirements for storage.
  9. Protect stored products from damage.
- B. Storage: Provide a secure location and enclosure at Project site for storage of materials and equipment by Owner's construction forces. Coordinate location with Owner.

## 1.7 PRODUCT WARRANTIES

- A. Warranties specified in other Sections shall be in addition to, and run concurrent with, other warranties required by the Contract Documents. Manufacturer's disclaimers and limitations on product warranties do not relieve Contractor of obligations under requirements of the Contract Documents.
- B. Special Warranties: Prepare a written document that contains appropriate terms and identification, ready for execution. Submit a draft for approval before final execution.
1. Manufacturer's Standard Form: Modified to include Project-specific information and properly executed.
  2. Specified Form: Forms are included with the Specifications. Prepare a written document using appropriate form properly executed.
  3. Refer to Divisions 2 through 16 Sections for specific content requirements and particular requirements for submitting special warranties.
- C. Submittal Time: Comply with requirements in Division 1 Section "Closeout Procedures."

## **PART 2 - PRODUCTS**

### 2.1 PRODUCT OPTIONS

- A. General Product Requirements: Provide products that comply with the Contract Documents, that are undamaged, and unless otherwise indicated, that are new at time of installation.
1. Provide products complete with accessories, trim, finish, fasteners, and other items needed for a complete installation and indicated use and effect.
  2. Standard Products: If available, and unless custom products or nonstandard options are specified, provide standard products of types that have been produced and used successfully in similar situations on other projects.
  3. Owner reserves the right to limit selection to products with warranties not in conflict with requirements of the Contract Documents.
  4. Where products are accompanied by the term "as selected," Architect will make selection.
  5. Where products are accompanied by the term "match sample," sample to be matched is Architect's.
  6. Descriptive, performance, and reference standard requirements in the Specifications establish "salient characteristics" of products.
  7. Or Equal: Where products are specified by name and accompanied by the term "or equal" or "or approved equal" or "or approved," comply with provisions in "Comparable Products" Article to obtain approval for use of an unnamed product.
- B. Product Selection Procedures: Procedures for product selection include the following:
1. Product: Where Specification paragraphs or subparagraphs titled "Product" name a single product and manufacturer, provide the product named.
    - a. Substitutions may be considered, unless otherwise indicated.
  2. Manufacturer/Source: Where Specification paragraphs or subparagraphs titled "Manufacturer" or "Source" name single manufacturers or sources, provide a product by the manufacturer or from the source named that complies with requirements.
    - a. Substitutions may be considered, unless otherwise indicated.
  3. Products: Where Specification paragraphs or subparagraphs titled "Products" introduce a list of names of both products and manufacturers, provide one of the products listed that complies with requirements.
    - a. Substitutions may be considered, unless otherwise indicated.
  4. Manufacturers: Where Specification paragraphs or subparagraphs titled "Manufacturers" introduce a list of manufacturers' names, provide a

product by one of the manufacturers listed that complies with requirements.

- a. Substitutions may be considered, unless otherwise indicated.
5. Available Products: Where Specification paragraphs or subparagraphs titled "Available Products" introduce a list of names of both products and manufacturers, provide one of the products listed or another product that complies with requirements. Comply with provisions in "Comparable Products" Article to obtain approval for use of an unnamed product.
  6. Available Manufacturers: Where Specification paragraphs or subparagraphs titled "Available Manufacturers" introduce a list of manufacturers' names, provide a product by one of the manufacturers listed or another manufacturer that complies with requirements. Comply with provisions in "Comparable Products" Article to obtain approval for use of an unnamed product.
  7. Product Options: Where Specification paragraphs titled "Product Options" indicate that size, profiles, and dimensional requirements on Drawings are based on a specific product or system, provide either the specific product or system indicated or a comparable product or system by another manufacturer. Comply with provisions in "Product Substitutions" Article.
  8. Basis-of-Design Products: Where Specification paragraphs or subparagraphs titled "Basis-of-Design Product[s]" are included and also introduce or refer to a list of manufacturers' names, provide either the specified product or a comparable product by one of the other named manufacturers. Drawings and Specifications indicate sizes, profiles, dimensions, and other characteristics that are based on the product named. Comply with provisions in "Comparable Products" Article to obtain approval for use of an unnamed product.
    - a. Substitutions may be considered, unless otherwise indicated.
  9. Visual Matching Specification: Where Specifications require matching an established Sample, select a product (and manufacturer) that complies with requirements and matches Architect's sample. Architect's decision will be final on whether a proposed product matches satisfactorily.
    - a. If no product available within specified category matches satisfactorily and complies with other specified requirements, comply with provisions of the Contract Documents on "substitutions" for selection of a matching product.
  10. Visual Selection Specification: Where Specifications include the phrase "as selected from manufacturer's colors, patterns, textures" or a similar phrase, select a product (and manufacturer) that complies with other specified requirements.

- a. Standard Range: Where Specifications include the phrase "standard range of colors, patterns, textures" or similar phrase, Architect will select color, pattern, or texture from manufacturer's product line that does not include premium items.
  - b. Full Range: Where Specifications include the phrase "full range of colors, patterns, textures" or similar phrase, Architect will select color, pattern, or texture from manufacturer's product line that includes both standard and premium items.
11. Allowances: Refer to individual Specification Sections and "Allowance" provisions in Division 1 for allowances that control product selection and for procedures required for processing such selections.

## 2.2 PRODUCT SUBSTITUTIONS

- A. **Timing: Architect will consider requests for substitution if received no later than 5 business days prior to bid opening.** Requests received after that time may be considered or rejected at discretion of Architect.
- B. Conditions: Architect will consider Contractor's request for substitution when the following conditions are satisfied. If the following conditions are not satisfied, Architect will return requests without action, except to record noncompliance with these requirements:
  - 1. Requested substitution offers Owner a substantial advantage in cost, time, energy conservation, or other considerations, after deducting additional responsibilities Owner must assume. Owner's additional responsibilities may include compensation to Architect for redesign and evaluation services, increased cost of other construction by Owner, and similar considerations.
  - 2. Requested substitution does not require extensive revisions to the Contract Documents.
  - 3. Requested substitution is consistent with the Contract Documents and will produce indicated results.
  - 4. Substitution request is fully documented and properly submitted.
  - 5. Requested substitution will not adversely affect Contractor's Construction Schedule.
  - 6. Requested substitution has received necessary approvals of authorities having jurisdiction.
  - 7. Requested substitution is compatible with other portions of the Work.
  - 8. Requested substitution has been coordinated with other portions of the Work.
  - 9. Requested substitution provides specified warranty.
  - 10. If requested substitution involves more than one contractor, requested substitution has been coordinated with other portions of the Work, is



uniform and consistent, is compatible with other products, and is acceptable to all contractors involved.

### 2.3 COMPARABLE PRODUCTS

- A. Where products or manufacturers are specified by name, submit the following, in addition to other required submittals, to obtain approval of an unnamed product:
1. Evidence that the proposed product does not require extensive revisions to the Contract Documents, that it is consistent with the Contract Documents and will produce the indicated results, and that it is compatible with other portions of the Work.
  2. Detailed comparison of significant qualities of proposed product with those named in the Specifications. Significant qualities include attributes such as performance, weight, size, durability, visual effect, and specific features and requirements indicated.
  3. Evidence that proposed product provides specified warranty.
  4. List of similar installations for completed projects with project names and addresses and names and addresses of architects and owners, if requested.
  5. Samples, if requested.

### **PART 3 - EXECUTION (Not Used)**

END OF SECTION 01600

**THIS PAGE LEFT INTENTIONALLY BLANK**



# SUBSTITUTION REQUEST (After the Bidding Phase)

Project: \_\_\_\_\_ Substitution Request Number: \_\_\_\_\_  
 \_\_\_\_\_  
 From: \_\_\_\_\_  
 To: \_\_\_\_\_ Date: \_\_\_\_\_  
 \_\_\_\_\_  
 A/E Project Number: \_\_\_\_\_  
 Re: \_\_\_\_\_ Contract For: \_\_\_\_\_

Specification Title: \_\_\_\_\_ Description: \_\_\_\_\_  
 Section: \_\_\_\_\_ Page: \_\_\_\_\_ Article/Paragraph: \_\_\_\_\_

Proposed Substitution: \_\_\_\_\_  
 Manufacturer: \_\_\_\_\_ Address: \_\_\_\_\_ Phone: \_\_\_\_\_  
 Trade Name: \_\_\_\_\_ Model No.: \_\_\_\_\_  
 Installer: \_\_\_\_\_ Address: \_\_\_\_\_ Phone: \_\_\_\_\_  
 History:  New product  2-5 years old  5-10 yrs old  More than 10 years old  
 Differences between proposed substitution and specified product: \_\_\_\_\_  
 \_\_\_\_\_  
 \_\_\_\_\_

Point-by-point comparative data attached - REQUIRED BY A/E

Reason for not providing specified item: \_\_\_\_\_  
 \_\_\_\_\_

Similar Installation:  
 Project: \_\_\_\_\_ Architect: \_\_\_\_\_  
 Address: \_\_\_\_\_ Owner: \_\_\_\_\_  
 \_\_\_\_\_ Date Installed: \_\_\_\_\_

Proposed substitution affects other parts of Work:  No  Yes; explain \_\_\_\_\_  
 \_\_\_\_\_

Savings to Owner for accepting substitution: \_\_\_\_\_ (\$ \_\_\_\_\_).  
 Proposed substitution changes Contract Time:  No  Yes [Add] [Deduct] \_\_\_\_\_ days.

Supporting Data Attached:  Drawings  Product Data  Samples  Tests  Reports  \_\_\_\_\_

# SUBSTITUTION REQUEST (Continued)

The Undersigned certifies:

- Proposed substitution has been fully investigated and determined to be equal or superior in all respects to specified product.
- Same warranty will be furnished for proposed substitution as for specified product.
- Same maintenance service and source of replacement parts, as applicable, is available.
- Proposed substitution will have no adverse effect on other trades and will not affect or delay progress schedule.
- Cost data as stated above is complete. Claims for additional costs related to accepted substitution which may subsequently become apparent are to be waived.
- Proposed substitution does not affect dimensions and functional clearances.
- Payment will be made for changes to building design, including A/E design, detailing, and construction costs caused by the substitution.
- Coordination, installation, and changes in the Work as necessary for accepted substitution will be complete in all respects.

Submitted by: \_\_\_\_\_

Signed by: \_\_\_\_\_

Firm: \_\_\_\_\_

Address: \_\_\_\_\_

Telephone: \_\_\_\_\_

Attachments: \_\_\_\_\_

---

### A/E's REVIEW AND ACTION

- Substitution approved - Make submittals in accordance with Specification Section 01330.
- Substitution approved as noted - Make submittals in accordance with Specification Section 01330.
- Substitution rejected - Use specified materials.
- Substitution Request received too late - Use specified materials.

Signed by:

Date:

---

Additional Comments:     Contractor     Subcontractor     Supplier     Manufacturer     A/E     \_\_\_\_\_

\_\_\_\_\_  
\_\_\_\_\_  
\_\_\_\_\_  
\_\_\_\_\_  
\_\_\_\_\_  
\_\_\_\_\_  
\_\_\_\_\_

**SECTION 01770**

**CONTRACT CLOSEOUT**

**PART 1.00 - GENERAL**

1.01 GENERAL REQUIREMENTS

- A. Work of this Section, as shown or specified, shall be in accordance with the requirements of the Contract Documents.

1.02 WORK INCLUDED

- A. Work of this Section includes all labor, materials, equipment, and services necessary to complete the contract closeout, including, but not limited to, the following:
  - 1. Punch list.
  - 2. Final cleaning.
  - 3. Warranties.
  - 4. Operating and maintenance data.
  - 5. Project record documents.
  - 6. Waiver of Release of Liens from All Suppliers and Sub-Contractors
  - 7. Certificate of Occupancy.

1.03 RELATED WORK

- A. Submittals - Section 01330.
- B. *Agreement.*

1.04 PUNCH LIST

- A. Contractor:
  - 1. Submit written declaration to Architect that project is substantially complete.
  - 2. Submit list of items to be completed or corrected.

- B. Owner, Construction Manager and Architect will make preliminary inspection after receipt to Contractor's declaration.
- C. Should Owner, Architect, and/or Construction manager consider that work is substantially complete:
  - 1. Architect will prepare a punch list of items to be completed or corrected, as determined by the inspection.
  - 2. Architect will prepare and issue a Certificate of Substantial Completion, containing:
    - a. Date of substantial completion.
    - b. Punch list of items to be completed or corrected.
    - c. The time within which Contractor shall complete or correct work of listed items.
    - d. Date or time Owner will assume possession of work or designated portion thereof.
- D. Contractor: Complete work listed for completion or correction, within designated time.

#### 1.05 FINAL INSPECTION

- A. Contractor shall submit written declaration to Owner, Architect and Construction Manager that:
  - 1. All aspects of Contract Documents have been complied with.
  - 2. All items on substantial completion punch list have been completed.
  - 3. All tools, construction equipment, and surplus materials have been removed from site.
- B. Contractor with Owner, Architect, and Construction Manager will make final inspection to ensure completion of all contract requirements.
- C. When Owner, Architect and Construction Manager consider that work is finally complete in accordance with Contract Document requirements, the Architect will prepare and process closeout documents.

## 1.06 FINAL CLEANING

- A. The Contractor shall be responsible for final cleaning. The building shall be prepared for occupancy by a thorough cleaning throughout, including washing (or cleaning by other approved methods) of surfaces on which dirt or dust has collected, and by washing glass on both sides. Wash exterior glass using a window cleaning contractor specializing in such work. Provide and maintain adequate runner strips of non-staining reinforced Kraft building paper on finished floors as required for protection. Leave equipment in an undamaged, bright, clean, and polished condition. Re-cleaning will not be required after the work has been inspected and accepted unless later operations of the Contractor make re-cleaning of certain portions necessary.
- B. Employ experienced workmen or professional cleaners for final cleaning.
- C. In preparation for Substantial Completion or occupancy, conduct final inspection of sight-exposed interior and exterior surfaces.
- D. Remove grease, dirt, dust, stains, labels, fingerprints and other foreign materials from sight-exposed interior and exterior finished surfaces; polish surfaces so designated to shine finish.
- E. Repair, patch and touch-up marred surfaces to specified finish, to match adjacent surfaces.
- F. Broom clean paved surfaces; rake clean "landscaped" grounds.
- G. Clean ducts, blowers and coils.

## 1.07 DOCUMENTS REQUIRED PRIOR TO FINAL PAYMENT

- A. Prior to final payment, and before the issuance of a final certificate of payment, the Contractor shall file the following papers with the Architect:
  - 1. Warranties: The warranty required by the *Agreement* and any other extended warranties stated in the technical Sections of the Specifications.
  - 2. Release of liens from contractor and all entitles of contractor.
  - 3. Consent of Surety to Final Payment.
  - 4. Contractor's Affidavit of Release of Liens (AIA G706A).

5. Contractors Affidavit of Payment of Debts and Claims (AIA G706)
6. Certification of Payment of Prevailing Wage Rates (If applicable).
7. Contractor's certified statement that no asbestos containing material was incorporated into the project.
8. Operation and Maintenance Manuals:
  - a. Furnish complete set of manuals in PDF format containing the manufacturer's instructions for maintenance and operation of each item of equipment and apparatus furnished under the contract and any additional data specifically required under the various Sections of the Specifications. Refer to Section 01330 - Submittals, for further requirements.
9. Project Record Documents:
  - a. As the work progresses, keep a complete and accurate record of changes or deviations from the Contract Documents and the shop drawings, indicating the work as actually installed. Changes shall be neatly and correctly shown on the respective portion of the affected document, using blackline prints of the drawings affected, or the specifications, with appropriate supplementary notes. This record set of drawings, shop drawings, and specifications shall be kept at the job site for inspection by the Architect and Owner.
  - b. The records above shall be arranged in order, in accordance with the various sections of the Specifications, and properly indexed. At the completion of the work, certify by endorsement thereof that each of the revised prints of the drawings and Specifications is complete and accurate. Prior to application for final payment, and as a condition to its approval by the Architect and Owner, deliver the record drawings and specifications, arranged in proper order, indexed, and endorsed as hereinbefore specified. Provide suitable transfer cases and deliver the records therein, indexed and marked for each division of the work.
  - c. No review or receipt of such records by the Architect or Owner shall be a waiver of any deviation from the Contract Documents or the shop drawings or in any way relieve the Contractor from his responsibility to perform the work in accordance with the Contract Documents and the shop drawings to the extent they are in accordance with the Contract



Documents.

10. Certificate of Occupancy: The Contractor shall obtain a Certificate of Occupancy and pay for these certificates and deliver them to the Architect.

1.08 EQUIPMENT SYSTEMS DEMONSTRATION

- A. Upon completion of the work and tests, instruct the Owner's Representative in the operation, adjustment and maintenance of systems and equipment furnished.
- B. The Owner will determine date of starting the instruction. The respective Subcontractor shall provide instructions for each system installed.

**PART 2.00 - PRODUCTS**

(Not Used)

**PART 3.00 - EXECUTION**

(Not Used)

END OF SECTION 01770



## **Section 04550 Concrete Repairs**

### Part 1 General

#### 1.1 Summary

The work of this section includes, repairs of concrete deck, spalls and cracks; and, treatment of rusted steel reinforcement.

#### 1.2 Related Sections

- A. Section 07015 - Preparation For Reroofing
- B. Section 07355 – Fully Adhered Thermoplastic Roofing
- C. Section 07621 – Thermoplastic Roofing Related Sheet Metal

#### 1.3 Submittals

Product Data: Submit 3 copies of all Manufacturer's product data, and referenced installation instructions for all materials to be incorporated into the work.

#### 1.4 Quality Assurance

- A. Only specified products may be incorporated into the work.
- B. Installer firm must have 5 years minimum experience with the types of materials specified.

#### 1.5 References. The following SIKA documents which are found in the SIKA RESTORATION SYSTEMS MANUAL are included by reference in this section:

- A. PREP -001, dated 0191.
- B. PREP -005, dated 0191.
- C. PREP -006, dated 0191.
- D. SPEC COMPONENT: SC-025-1291
- E. SPEC COMPONENT: 50-200-1 291
- F. SPEC COMPONENT: SC-201-1291

#### 1.6 Delivery, Storage and Handling

Deliver materials and products to the job site in packages with Manufacturers' labels. Store and handle all materials in strict accordance with Manufacturers' printed instructions. Protect materials from damage from sunlight, weather, excessive temperatures and construction activities.

## Part 2 Materials

- 2.1 One component, early strength gaining, cementitious patching material shall be SikaRepair 223 as manufactured by SIKA CORPORATION, Lyndhurst, NJ.
- 2.2 Coating for steel reinforcements and bonding bridge for prepared concrete surfaces shall be Sika Armatec 110 EpoCem as manufactured by SIKA CORPORATION, Lyndhurst, NJ.
- 2.3 Accessory products, as may be required, shall be as recommended by SIKA CORPORATION, Lyndhurst, NJ.

## Part 3 Execution

- 3.1 Perform all repair work in strict accordance with the referenced material.
- 3.2 Repair damaged sections of concrete decking as required. Furnish and install. Include 5, 50 lb bags of repair material for repairs as part of base bid.
- 3.3 Bring problems effecting the successful completion of this section of work to the immediate attention of the Consultant.
- 3.4 Notify Consultant when repair work is complete. Do not install waterproofing until the Owner's Representative has inspected and approved the work of this section.

End of Section 04550

## **Section 04552 Masonry Restoration**

### Part I General

#### 1.1 Description of Work:

- A. The work in this section includes, but is not limited to, the following:
  - 1. Remove and reset existing coping stones.

#### 1.2 Related Work Specified Elsewhere

- A. Section 04550 - Concrete Repair
- B. Section 05310 – Steel Decking Inspection, Fastening and Repair
- C. Section 07015 – Preparation For Re-Roofing
- D. Section 07355 – Fully Adhered Thermoplastic Roof Covering
- E. Section 07621 – Thermoplastic Roofing Related Sheet Metal

#### 1.3 Coordination

- A. Coordinate the work of this section with all other sections for the successful completion of the Contract.

#### 1.4 Applicable Codes and Standards

- A. American Society for Testing and Materials (ASTM)
  - 1. ASTM C270: Standard Specification for Mortar for Unit Masonry
  - 2. ASTM specifications regulating the quality of any product specified herein
- B. Secretary of the Interior Standards for Rehabilitation
- C. ASTM E 96 \_ Test Methods for Water Vapor Transmission of Materials
- D. ASTM D 570 \_ Test Method for Water Absorption of Plastics
- E. ASTM E 154 \_ Test Method for Water Vapor Retarders used in contact with Earth Under Concrete Slabs, on Walls or as Ground Cover.

#### 1.5 Quality Assurance

- A. Submit resume demonstrating a minimum of five (5) years experience re-pointing

masonry. Provide at least three references for projects of similar size and materials. Carefully supervise mechanics to ensure that the work is accomplished to meet or exceed the highest standards of the trade.

- B. Order sufficient materials to cover entire project.
- C. Provide regular access to the scaffolding and worksite so that the Owner's representative's Representative may easily inspect work being performed.
- D. Replace at no additional expense to the Owner's representative all broken, lost, damaged material resulting from the work conducted in this section.
- E. Perform work on a daily basis without interruption unless directed otherwise by the Owner's representative.
- F. In acceptance or rejection of re-pointing operations, no allowance will be made for lack of skill on the part of the mechanics.

#### 1.6 Submittals

- A. Product Literature: Submit copies of the manufacturer's technical data for each product including their recommendations for installation and use. Include any product data and MSDS. Include test reports and certificates that verify the product's compliance with the specification's requirements.

#### 1.8 Product Handling

- A. Deliver materials to the job site in original, unopened containers bearing manufacturer name and label. Store and handle materials in strict compliance with manufacturer's instructions. Do not store on ground.
- B. Protect materials from tampering, acts of vandalism, possible injury to workers, the general public, intrusion of foreign materials, and moisture. All vessels shall have tight fitting covers.

#### 1.9 Project Conditions

- A. Weather: Perform exterior pointing work only when existing temperature is between 40°F and 80°F and will remain so for at least 48 hours after completion of work. Protect newly finished work from direct rainfall.
- B. Protection: Prevent construction materials from staining faces of the masonry. Protect all adjacent surfaces, ledges, and projects from droppings.

## Part 2 Products

### 2.1 General

- A. Fastening (General): Furnish bolts, nuts, screws, clips, washers and other fastenings necessary for proper erection of items specified.
- B. For Ferrous Metal: Use stainless steel or galvanized, G90 Coating, on exterior.

### 2.2 Modified Bituminous Sheet Waterproofing:

- A. Grace: Perm-A-Barrier Wall Membrane
- B. Air & Vapor Barrier Accessories:
  - 1. Surface Conditioner:
    - a. Perm-A-Barrier Surface Conditioner manufactured by Grace Construction Products.
  - 2. Termination Mastic
    - a. Bituthene Mastic manufactured by Grace Construction Products.
  - 3. Primer:
    - a. Bituthene Primer B2 by Grace Construction Products.

### 2.3 Coping Removal and Reinstallation

- A. Dowels: 3/8" Stainless Steel Dowels
- B. "L" Anchor: 1/8" thick x 1/4" wide Stainless Steel
- C. Fasteners: Powers Stainless Steel Expansion Pins
- D. Sealant: Tremco General Purpose Butyl Sealant

### 2.4 Mortar Products

- A. Match color, texture, joint size, and type of original mortar as closely as possible. Mortar is to be approved by Owner's Representative prior to installation.
- B. Aggregate: Provide aggregate to match existing aggregate in terms of color, angularity, and gradation. Note: this may require the use of 'specialty' aggregate.
- C. Cement: Provide Portland Cement, Type I, in accordance with ASTM C150

- D. Lime: Hydrated lime shall be in accordance with ASTM C207 and shall be Type S.
- E. Pigment: Use only alkali-stable inorganic pigments with proven record of satisfactory performance. Mortar colors are to be approved by Owner's Representative before installation.
- F. Water: Potable.

### PART 3 Execution

#### 3.1 Inspection:

- A. Examine substrates, supports, and conditions under which this work is to be performed and notify the Owner's Representative in writing of conditions detrimental to the proper completion of the work. Do not proceed with work until unsatisfactory conditions are corrected. Beginning work signifies installer's acceptance of substrates and conditions.

#### 3.2 Stone Coping Removal and Replacement:

- A. Remove all stone coping, install specified cap flashing and reinstall existing stone coping with specified dowels and "L" brackets.
- B. Assure heavy bead of butyl sealant is placed in each hole created in cap flashing and below all "L" brackets.

#### 3.3 Final Cleaning

- A. After mortar has fully hardened, thoroughly clean exposed masonry surfaces of excess mortar and foreign matter using stiff nylon or Tampico bristle brushes and clean water spray applied at low pressure (> 500 psi).
- B. Do not use metal scrapers or metal brushes.

End of Section 04552



**Section 05310**  
**Steel Decking Inspection, Fastening and Repair**

Part 1 General

- 1.1 Description: This section specifies material and services required for inspection, fastening and repair of the steel decking.
- 1.2 Related Sections
  - A. Section 07015 - Preparation For Reroofing
  - B. Section 07355 – Fully Adhered Thermoplastic Roofing
  - C. Section 07621 – Thermoplastic Roofing Related Sheet Metal
- 1.3 Submittals
  - A. Manufacturers' literature pertaining to all products to be used in conjunction with the work of this section.
  - B. As Built Drawings showing the location of all deck replacements and repairs.
- 1.4 Quality Assurance
  - A. FM Listing: Provide metal roof deck units which have been evaluated by Factory Mutual Global and are listed in "Factory Mutual Research Approval Guide" for "Class 1" fire rated construction.
- 1.5 Applicable Publications
  - A. Factory Mutual (FM Global):
    - 1. Loss Prevention Data Sheet 1-28: Wind Loads to Roof Systems and Roof Deck Securement
    - 2. Factory Mutual Research Approval Guide (Latest Edition)

Part 2 Products

- 2.1 Materials
  - A. Replacement Decking: FM approved SS grade 80 steel deck to match the gauge and profile of existing decking. Verify the exact profile needed before ordering decking
  - B. Deck Fasteners
    - 1. Deck to joists: ITW Buildex Traxx/5 screws and ¾ inch Hillman flat washers with ¼ inch diameter holes.

2. Side laps: ITW Buildex Traxx/1 screws.

C. Deck Coating / Paint: Zinc rich paint

### Part 3 Execution

- 3.1 Inspect the existing decking following demolition. Bring conditions requiring repair to the immediate attention of the Architect.
- 3.2 Remove damaged sections where directed by Architect's direction. Install replacement decking per referenced FMG instructions.
- 3.3 Prepare, sand, scrape and paint areas where steel decking can be nested.
- 3.4 Prepare, scrape and paint rusted decking where directed by Architect.

End of Section 05310

## Section 07015 Preparation For Re-Roofing

### Part 1 General

#### 1.1 Description

- A. Roof tear-off of existing construction in preparation to receive new roofing membrane / shingles.
- B. Existing Membrane Roofing System: Built-up asphalt with related insulation, surfacing, and components and accessories between deck and roofing membrane.

#### 1.2 Related Sections

- A. Section 04550 – Concrete Repairs
- B. Section 04552 – Masonry Restoration
- C. Section 05310 – Steel Decking Inspection, Fastening and Repair
- D. Section 07355 – Fully Adhered Thermoplastic Roofing
- E. Section 07621 – Thermoplastic Roofing Related Sheet Metal

#### 1.3 Applicable Publications

- A. Publications listed below form a part of this specification to the extent referenced. Publications are referenced in the text by the basic designation only. Editions of applicable publications current on date of issue of bidding documents apply unless otherwise indicated.
- B. American National Standards Institute/Single-Ply Roofing Institute (ANSI/SPRI):ANSI/SPRI FX-1-01(R2006) Standard Field Test Procedure for Determining the Withdrawal Resistance of Roofing Fasteners.
- C. ASTM International (ASTM):
  - C208-08 ..... Cellulosic Fiber Insulating Board
  - C728-05 ..... Perlite Thermal Insulation Board
  - C1177/C1177M-08..... Standard Specification for Glass Mat Gypsum Substrate for Use as Sheathing
  - C1278/C1278M-07..... Standard Specification for Fiber-Reinforced Gypsum Panel
  - D1079-09 ..... Standard Terminology Relating to Roofing and Waterproofing

- D. FM Approvals: RoofNav Approved Roofing Assemblies and Products.
  - 4450-89..... Approved Standard for Class 1 Insulated Steel Deck Roofs
  - 4470-10..... Approved Standard for Class 1 Roof Coverings
  - 1-28-09 ..... Loss Prevention Data Sheet: Design Wind Loads.
  - 1-29-09 ..... Loss Prevention Data Sheet: Above-Deck Roof Components
  - 1-49-09 ..... Loss Prevention Data Sheet: Perimeter Flashing
- E. National Roofing Contractors Association: Roofing and Waterproofing Manual

1.4 Materials Ownership

- A. Assume ownership of demolished materials and remove from Project site and dispose of legally, unless indicated to be reused, reinstalled, or otherwise to remain Owner's property.

1.5 Definitions

- A. Refer to ASTM D1079 and NRCA "The NRCA Roofing and Waterproofing Manual" for definition of terms.

1.6 Quality Control

- A. Requirements of Division 07 roofing section for qualifications of roofing system and roofing insulation Installer; work of this section shall be performed by same Installer.
  - 1. Where Project requirements include removal of asbestos-containing material, Installer must be legally qualified to perform the required work.
  - 2. Where Project requirements include work affecting existing roofing system to remain under warranty, Installer must be approved by warrantor of existing roofing system.
- B. Regulatory Requirements: Comply with governing EPA notification regulations. Comply with hauling and disposal regulations of authorities having jurisdiction.
- C. Reroofing Conference: Conduct conference at Project site.
  - 1. Meet with Owner; Architect, Consultant; testing and inspecting agency representative; roofing system manufacturer's representative; roofing

Installer including project manager, superintendent, and foreman; and installers whose work interfaces with or affects reroofing.

2. Review methods and procedures related to roofing system tear-off and replacement.

#### 1.7 Submittals

- A. Submit in accordance with Sections 07355, 07620 and SHOP DRAWINGS, PRODUCT DATA, AND SAMPLES.
- B. Manufacturer's Literature and Data.
- C. List of proposed infill materials.
- D. List of proposed temporary roofing materials.
- E. Fastener pull-out test report.
- F. Photographs or Videotape: Document existing conditions of adjacent construction including site improvements.
- G. Landfill Records: Indicate receipt and acceptance of hazardous wastes by a licensed landfill facility.
- H. Qualification Data: For Installer.
  1. Certificate indicating Installer is licensed to perform asbestos abatement.
  2. Certificate indicating Installer is approved by warrantor of existing roofing system.

#### 1.8 Project Conditions

- A. Owner will occupy portions of building below reroofing area. Conduct reroofing so Owner's operations will not be disrupted.
  1. Coordinate work activities daily with Owner.
  2. Provide Owner with not less than 72 hours' notice of activities that may affect Owner's operations.
- B. Protect building and landscaping from damage.
- C. Maintain access to existing walkways and adjacent occupied facilities.
- D. Weather Limitations: Proceed with reroofing preparation only when weather conditions permit Work to proceed without water entering existing roofing system or building.

- E. Hazardous Materials: A report on the presence of hazardous materials is available to Contractor for review and use.
  - 1. Examine report to become aware of locations where hazardous materials are present.
  - 2. Hazardous material remediation is specified elsewhere in the Contract Documents.

## 1.9 Warranty

- A. Existing Warranties: Remove, replace, patch, and repair materials and surfaces affected by reroofing, by methods and with materials acceptable to warrantor.
  - 1. Notify warrantor of existing roofing system before proceeding, and upon completion of reroofing.
  - 2. Obtain documentation verifying that existing roofing system has been inspected by warrantor and warranty remains in effect. Submit documentation at Project closeout.

## Part 3 Execution

### 3.1 Preparation

- A. Protect existing membrane roofing system that is indicated not to be reroofed.
  - 1. Limit traffic and material storage to areas of existing roofing membrane that have been protected.
  - 2. Maintain temporary protection and leave in place until replacement roofing has been completed. Remove temporary protection on completion of reroofing.
- B. Coordinate with Owner to shut down air-intake equipment in the vicinity of the Work. Cover air-intake louvers before proceeding with reroofing work that could affect indoor air quality or activate smoke detectors in the ductwork.
  - 1. Comply with Owner's requirements for maintaining fire watch when temporarily disabling smoke detectors.
- C. During removal operations, have sufficient and suitable materials on-site to facilitate rapid installation of temporary protection in the event of unexpected rain.

- D. Maintain roof drains in functioning condition to ensure roof drainage at end of each workday. Prevent debris from entering or blocking roof drains and conductors. Use roof-drain plugs specifically designed for this purpose. Remove roof-drain plugs at end of each workday, when no work is taking place, or when rain is forecast.
  - 1. If roof drains are temporarily blocked or unserviceable due to roofing system removal or partial installation of new membrane roofing system, provide alternative drainage method to remove water and eliminate ponding.
  - 2. Do not permit water to enter into or under existing membrane roofing system components that are to remain.

### 3.2 Roof Tear Off

- A. General: Notify Owner each day of extent of roof tear-off proposed for that day and obtain authorization to proceed.
- B. Roof Tear-Off: Remove existing roofing membrane and other membrane roofing system components down to the deck.
  - 1. Comply with FM Approvals requirements for removal of excess asphalt from steel decks.
  - 2. Remove fasteners from deck prior to installing roof membrane.
  - 3. Coordinate with Consultant to schedule times for tests and inspections immediately after membrane removal.

### 3.3 Deck Preparation

- A. Inspect deck after tear-off or partial tear-off of membrane roofing system.
- B. Verify that the substrate is visibly dry and free of moisture.
- C. If broken or loose fasteners that secure deck panels to one another or to structure are observed or if deck appears or feels inadequately attached, immediately notify Architect. Do not proceed with installation until directed by Architect.
- D. If deck surface is not suitable for receiving new roofing or if structural integrity of deck is suspect, immediately notify Architect. Do not proceed with installation until directed by Architect.

### 3.4 Existing Base Flashings

- A. Remove existing base flashings around parapets, curbs, walls, and penetrations.
  - 1. Clean substrates of contaminants such as asphalt, sheet materials, dirt, and debris.
- B. Do not damage metal counterflashings that are to remain. Replace metal counterflashings damaged during removal with counterflashings specified in Section 07620 and Section 07622.

### 3.5 Disposal

- A. Collect demolished materials and place in containers. Promptly dispose of demolished materials. Do not allow demolished materials to accumulate on-site.
  - 1. Storage or sale of demolished items or materials on-site is not permitted.
- B. Transport and legally dispose of demolished materials off Owner's property.

End of Section 07015



## Part 1 General

### 1.1 Description

A. This section describes a fully adhered, fleece backed thermoplastic single ply roof assembly installed over siliconized gypsum, new flat & tapered polyisocyanurate insulation, concrete deck and steel roof decking.

B. Related Sections:

1. Section 04550 – Concrete Repairs
2. Section 04552 – Masonry Restoration
3. Section 05310 – Steel Decking Inspection, Fastening and Repair
4. Section 07015 – Preparation For Re-Roofing
5. Section 07621 - Roof Related Sheet Metal

C. This Section has been based upon the materials and, in part, product specific requirements of Seaman Corporation for their FiberTite® Roof System.

This is not intended to limit competition, and products of other Roofing System Manufacturers (RSM) may be submitted for approval. Approved manufacturers include Sika Sarnafil, Johns Manville and GAF.

Wherever the phrase “or as approved” is used in this section it means that materials, components and equipment may be proposed for work in lieu of those named. They will be considered acceptable if, in the opinion of the Architect, they will perform the functions imposed by the general design and, if they meet the standards of the items named and the Manufacturer agrees in writing to the provisions of this section of the specifications.

### 1.2 Submittals

- A. Submit 3 sets of the following to the Consultant and receive written approval before ordering materials.
1. Samples of all materials to be used as part of the roofing system.
  2. Current technical literature pertaining to the installation of the roofing system to be used.
  3. Dimensioned roof plan, including defined tapered insulation layouts, perimeter and corner areas and shop drawings bearing approval by the Roofing System Manufacturer.

4. A letter from an authorized technical representative of the Manufacturer, including as an attachment a Contractor submitted "Specification Registration" form and specimen warranty, stating:
  - a. The Contractor is an authorized applicator of the Manufacturer's warranted roofing systems.
  - b. The Manufacturer has reviewed and accepted the attached "Specification Registration" form.
  - c. The specified warranty will be issued upon successful completion of the project.
- B. Prior to the commencement of work the Contractor shall provide a resume for the Foreman and Project Manager assigned to the Project. If these individuals are replaced during the Project resumes for their replacements shall also be submitted.
- C. At the completion of the project provide:
  1. "As built" drawings showing the location of all projections and penetrations, and any modifications that were made.
  2. The primary roofing material Manufacturer's printed recommendations for proper maintenance of the roofing system including recommended inspection frequencies, roof modification notification policies, temporary repair recommendations and leak reporting procedures.
  3. Dated seam cuts from each day of production.

### 1.3 Quality Assurance

- A. The Roofing Contractor shall be authorized by the Roofing Membrane Manufacturer to install the systems specified.
- B. The Foreman, including any substitute or replacement Foreman, assigned to the Project must have a minimum of 10 year's experience with fully adhered thermoplastic single ply membranes.
- C. FM Global: Install system in accordance with FM Global recommendations. Roof NAV 122276-0-0 (Concrete) and Roof NAV 122156-0-0 (Steel).

### 1.4 Warranty

- A. Deliver to the Manager the Manufacturer's 20-year labor and materials total system warranty, including proprietary sheet metal fabrications. The warranty shall not be prorated nor shall it have any deductibles or limitation on coverage amount.

Include 110 mile per hour windspeed rider within the full system warranty.

## Part 2 - Products

- 2.1 Roofing System Components: Products shall be supplied by or acceptable to Seaman Corporation
- A. Roofing Membrane: 45 mil FiberTite-SM-FB or approved equal.
  - B. Flashing Membrane: FiberTite XT or approved equal.
  - C. Bonding Adhesive (horizontal): FTR #490 or approved equal.
  - D. Bonding Adhesive (vertical): FTR #190 Mastic or approved equal.
  - E. Sealant for certain flashing terminations: FTR #101 one component polyurethane or approved equal.
  - F. Clad Metal: FiberClad Metal (Aluminum) or approved equal.
  - G. Vent stacks/Outside Corners/Inside Corners: FTR Pre-molded components or approved equal.
  - H. Non reinforced Flashing Sheet for Certain details: FTR Non Reinforced Flashing or approved equal.
  - I. Termination Bar: FTR- termination bar or approved equal.
  - J. Walk ways: FTR-Tuff track Walk Pads or approved equal.
  - K. Flashing Membrane: FiberTite XT or approved equal.
  - L. Bonding Adhesive (horizontal): FTR #490 or equal equal.
  - M. Bonding Adhesive (vertical): FTR #190 Mastic or approved equal.
  - N. Sealant for certain flashing terminations: FTR #101 one component polyurethane or approved equal.
  - O. Clad Metal: Thermoplastic Clad Metal (Aluminum) or approved equal.
  - P. Vent stacks/Outside Corners/Inside Corners: FTR Pre-molded components or approved equal.
  - Q. Non reinforced Flashing Sheet for Certain details: FTR or approved equal.
  - R. Termination Bar: FTR- termination bar or approved equal.
  - S. Walk ways: FTR-Tuff track Walk Pads or approved equal.

2.2 Polyisocyanurate roof insulation is manufactured to meet and/or exceed Federal Specifications: ASTM C1289 Type II, Class I, Grade 3.

A. Flat and tapered polyisocyanurate shall be 25 PSI. The physical properties of the foam shall be:

Property	Test Method	Result
Water absorption	ASTM C209	<1% (foam only)
Dimensional Stability`	ASTM D2126	2% max (7 days (Length and Width)
Compressive Strength	ASTM D1621	25 PSI
Moisture vapor Trans	ASTM E96	<1 perm
Service temperature		-100F-250F
Flame Spread	ASTM E84	@25 (foam core only)

B. Siliconized gypsum sheathing overlay shall be Georgia Pacific ¼ inch Dens Deck Prime, manufactured by Georgia Pacific Corporation: Atlanta, GA.

C. Insulation attachment:

1. First layer: HD Insulation Fasteners and Plates (Steel) or approved equal.
2. First (Concrete) Second and successive layers, crickets and siliconized gypsum overlay and: OlyBond Adhesive or approved equal.

2.3 Nailers, Blocking: No. 2 kiln dried (19% maximum moisture content after treatment), grade marked, and surfaced on four sides.

2.4 Non-Insulation Fasteners:

- A. Wood to heavy gauge steel: TEKS-Self Drilling Fasteners.
- B. Wood to wood: POWERS/Rawl: # 10 Perma-seal deck screws. Length shall be sufficient to achieve 1-inch penetration. Nails are not permitted.
- C. Fasteners for securing Termination bar to concrete or brick: RAWL: stainless steel Zamac Nailinâ Length shall be sufficient to achieve 3/4 inch embedment.

2.5 Drains: ZURN ZA 100 series with underdeck clamping provisions or approved equal.

- A. Dome: aluminum.
- B. Pipe outlet: match existing size.
- C. Outlet type: per code.

2.6 Expansion Joint:

- A. Johns Manville Expand-o-flash or approved equal.
  - 1. Aluminum Flanged Curb to Curb
  - 2. Aluminum Flanged Curb to Wall
  - 2. Assure factory fabricated transitions are used in all transitions.
  - 3. Joints and tie-ins to adjacent existing bellows expansion joints to be completed with a two-step process. One layer of 6-inch EPDM stripping and one layer of 12 inch EPDM stripping.

2.7 Roof Edge Protection Railing:

- A. Kee Guard Contractor or approved equal.

2.8 Fluid Applied Flashing:

- A. Siplast Parapro or approved equal.

Part 3 Execution

3.1 General

- A. These Specifications may further limit the installation options from those generally acceptable to FiberTite®

3.2 Substrate Preparation:

- A. Demolition:
  - 1. Remove all drains, existing built up roofing, flashings, pitch pockets and sheet metal components. Contractor responsible for terminating and capping abandoned drain lines to meet Connecticut Plumbing code standards.

**Refer to asbestos report for abatement of ACM materials.**

- B. Install plywood meeting FiberTite requirements on all vertical surfaces to assure acceptable substrate.

## C. Drains:

1. Use plumbers licensed in the State of Connecticut for this work.
2. Install replacement drain bodies' level with the deck. Do not proceed with work in the contributory area of an individual drain until that drain has been replaced and connected to interior plumbing.
3. Install specified replacement drains at existing locations to meet local building code.
4. Assume sole responsibility to verify that all drains are unobstructed at the end of the project whether or not clogging was a result of the work. Assume responsibility for the cost associated with unclogging drains.

## D. Wood Blocking:

1. Resecure existing perimeter nailers:
  - a. Install one fastener within 6 inches of the end of each length of nailer and one fastener per lineal foot throughout.
  - b. Replace damaged nailers. Allow for the replacement of 50 lineal feet of 2-inch by 10-inch nailer in your Bids. Consultant to determine where nailers are replaced.
2. New Blocking:
  - a. Install wood blocking around perimeter and penetrations where shown on the drawings to meet new insulation height or required by the RSM
  - b. Anchor new blocking sufficiently to resist a 250-pound per lineal foot force in all directions. Use only specified threaded fasteners. As a minimum:
    - i. Install two fasteners per length of blocking.
    - ii. Install one fastener within 6 inches of each end of each length of blocking.
    - iii. Space fasteners 12 inches OC between the two end fasteners.
    - iv. Fasten each course of blocking separately.
    - v. Maintain a constant perimeter elevation  $\frac{1}{4}$  inch higher than the highest achieved insulation/overlay elevation.

- 3.3 Insulation Installation: Comply with RSM's insulation handling and installation recommendations. Cut insulation to fit around all projections.
- A. Multiple Layers: Stagger joints of each layer at least 12" in each direction.
  - B. Secure first layer of insulation with specified fasteners (**Steel Deck**)
    1. Field: 11 Per 4' x 8' board, 6 Per 4'x4' board
    2. Perimeter:(8 feet) 16 Per 4'x8' board, 8 on 4'x4' board
    3. Corner:(Intersection of Perimeter) 20 Per 4'x8' board, 10 on 4'x4' board
  - C. Install first (**Concrete Deck**), second and successive layers of insulation and coverboard with specified adhesive.
    1. Field: Adhesive:12" on center beads (4'x4' board)
    2. Perimeter:(8 feet) 6" on center beads (4'x4' board)
    3. Corner:(Intersection of Perimeter) 3" on center beads (4'x4' board)
  - D. Insulation Criteria:
    1. Minimum R-30.
    2. Install 1/4 inch per foot tapered insulation in field, 1/2 Inch per foot slope at crickets.
- 3.4 Membrane Installation:
- A. Follow instructions printed in the referenced FiberTite® I Literature.
  - B. Seam Welding
    1. Use approved hot air welding techniques for laps. Solvent welding techniques are prohibited.
    2. Use Seaman approved self-propelled welding machines for field seams. Limit use of hand held hot air welding tools to instances unsuited to self-propelled welding machines.
    3. Supply portable generators acceptable to roofing Manufacturer.
    4. **Perform two seam cuts per day (one in the morning and one in the afternoon). Sign and date each cut. Save accumulated samples on site for examination by the Consultant and Manufacturer. Submit samples to Consultant at the conclusion of the project.**

5. All seams complete in that day to be probed and signed by person completing probing. All payment requisitions will be held until this is completed.
- 3.5 Flashing Installation: Generally follow Manufacturer's printed requirements and the instructions on the Drawing.
  - A. Refer to drawings for additional information.
  - B. Penetration pans are to be installed on items with a diameter of less than 1 inch. All other items will be field wrapped. In the event that this item is ignored, the areas in question will be ripped out and redone properly.
- 3.6 Expansion Joint: Install expansion joint where shown on the drawings according to the manufacturers printed instructions. Extend expansion joints to outside edge of the building and return down. All transitions are to be factory fabricated.
- 3.7 Perimeter Edge Safety Rail:
  - A. Install specified perimeter edge rail system at mechanical equipment that lands within feet of the edge or open side of a walking surface and skylights.
- 3.8 Fluid Applied Flashing:
  - A. Install specified Fluid Applied Flashing where shown on drawings.
- 3.9 Walkways:
  - A. Install walk pads where shown on roof plan, around all mechanical equipment, and where required by RSM.

End of Section 07355



## Part 1 General

### 1.1 Section Includes

- A. This Section includes proprietary metal edging, drip edge, through wall counterflashing, sleeve metal and other roof system related sheet metal fabrications.
- B. Refer to Drawings and referenced literature for other pertinent information.
- C. SMACNA references are to SMACNA Architectural Sheet Metal Manual, 5th Edition.

### 1.2 Related Sections:

- A. Section 04550 – Concrete Repair
- B. Section 04552 – Masonry Restoration
- C. Section 05310 – Steel Decking Inspection, Fastening and Repair
- D. Section 07015 – Preparation For Re-Roofing
- E. Section 07355 – Fully Adhered Thermoplastic Roofing

### 1.3 Submittals: Submit 3 sets of the following to the Consultant within 10 days after receiving a Notice to Proceed:

- A. Samples of exposed formed sections, if requested.
- B. Shop Drawings for basic conditions, showing dimensions for sheet metal and wood blocking as well as fastening specifics: type, length and density. Prepare Shop Drawings in conjunction with those prepared to fulfill the requirements of Section 07355.

### 1.4 Quality Assurance

- A. Comply with the standards specified in this section, those shown on the Project Drawings and as listed elsewhere.
- B. Qualifications of the Manufacturers: Products used in the work of this section shall be produced by manufacturers regularly engaged in the manufacture of similar items and with a history of successful production and product installations.

- C. Qualifications of the Installers: Installers shall be thoroughly trained and experienced in the necessary crafts.

In the acceptance or rejection of the Work of this section, no allowance will be made for lack of skill or specification understanding on the part of the workers. It shall be incumbent upon the Contractor to use adequate numbers of skilled installers and to instruct them in the requirements of the project specifications.

- 1.5 Warranty: Include proprietary fabrications within the Roof Full System Warranty 20 year duration.

## Part 2 Products

### 2.1 Metal Edge (3 Piece)

- A. ES-1 Rated Metal Edge

- 1. Shop fabricated from .050 Kynar finished aluminum
- 2. Continuous cleats fabricated from .050 mill finished aluminum

### 2.2 Proprietary Through Wall Counterflashing: Two-piece counterflashing shall be equal to those manufactured by the Keystone Flashing Company, Philadelphia or approved equal.

- A. Receiver shall be fabricated to match the profile shown on the Project Drawings and shall have a 1-inch face on the inside of the parapet. The receiver shall have a ¼ inch hem return on the outside edge.
- B. Receiver shall be formed of 16-ounce cold rolled copper with a special vertical locking slot that requires no malleting or bending to hold the insert member in place.
- C. Flashing insert shall have a 4-inch exposed face. The insert members shall be formed of 16-ounce cold rolled copper and designed to snap lock into the receiver portion and provide a spring like hug against the base flashing.
- D. Lock/rivet and solder joints.
- E. Install expansion joints in counterflashing every 30 lineal feet to allow for expansion and contraction. Expansion Joints to be installed per SMACNA recommendations.
- F. Solder: 50% block tin and 50 % pig lead, conforming to ASTM B32.

- G. Flux: Muriatic acid killed with zinc, or as approved.
  - H. Rivets: 1/8 inch Copper.
  - I. Secure with masonry fasteners specified in 07355 and seal back leg of counterflashing to backup masonry with fluid applied flashing specified in section 07355 per Contract Drawings.
- 2.3 Masonry: Replacement of masonry units used to restore walls opened to install new thru wall flashings.
- A. Replacement units: Conform to ASTM 126 SW. Match existing. Provide units matching sample approved by Consultant. Removed units may be reinstalled provided they are sound.
  - B. Mortar: Type N. Color to match existing.
- 2.4 Proprietary Cap Flashing: 3 – Way, Two piece cap flashing shall be equal to those manufactured by the Keystone Flashing Company, Philadelphia or approved equal.
- A. Receiver shall be fabricated to match the profile shown on the Project Drawings and shall have a 1-inch face on the inside of the parapet. The receiver shall have a ¼ inch hem return on the outside edge.
  - B. Receiver shall be formed of 16 cold rolled copper with a special vertical locking slot that requires no malleting or bending to hold the insert member in place.
  - C. Flashing insert shall have a 4-inch exposed face. The insert members shall be formed of 16 cold rolled copper and designed to snap lock into the receiver portion and provide a spring like hug against the base flashing.
  - D. Lock/rivet and solder joints.
  - E. Install expansion joints in counterflashing every 30 lineal feet to allow for expansion and contraction. Expansion Joints to be installed per SMACNA recommendations.
  - F. Solder: 50% block tin and 50% pig lead, conforming to ASTM B32.
  - G. Flux: Muriatic acid killed with zinc, or as approved.
  - H. Rivets: 1/8 inch Copper
- 2.5 Sleeve Metal:
- A. Fabricate from .040 mill finish aluminum.

2.6 Drip Edge (Windows):

- A. Shop fabricate from .040 mill finish aluminum.

Part 3 Execution

3.1 General

- A. Examine the areas and conditions under which the Work of this section will be performed. Correct detrimental conditions.
- B. Do not allow dissimilar metals to come in contact with one another. Provide bituminous paint or other protective coating on concealed surfaces to prevent interaction of materials.
- C. Field verify dimensions shown on the Drawings. Form sheet metal accurately and to the required dimensions and shapes.
- D. Comply with pertinent recommendations contained in "Architectural Sheet Metal Manual", 1993 (5<sup>th</sup>) edition, as published by SMACNA.

3.2 Install new metal edge where indicated on drawings:

- A. Install new edge per Smacna guidelines and project drawings.
- B. Assure all fastening to existing stone is predrilled to avoid damage.
- C. New edge to meet extent of surrounding metal. In cases where surrounding metal does not exist assure new metal extends ¼ inch beyond the existing.
- D. Metal edge exceeding 10 inches is to be completed using a two-piece installation.

3.3 Proprietary Thru-Wall Counterflashing:

- A. Install specified Proprietary Thru Wall Counterflashing where shown on drawings.

3.4 Proprietary Cap Flashing:

- A. Install specified Proprietary Cap Flashing where shown on drawings.

3.5 Sleeve Metal:

- A. Install sleeve metal where indicated on drawings.

3.6 Drip Edge (Windows):

- A. Install window drip edge where indicated on drawings.

End of Section 07621





# Roof Replacement at: Stratford Academy - Johnson House

## 719 Birdseye St., Stratford, CT



2725 Main Street  
Stratford, CT 06614

### LOCATION MAP

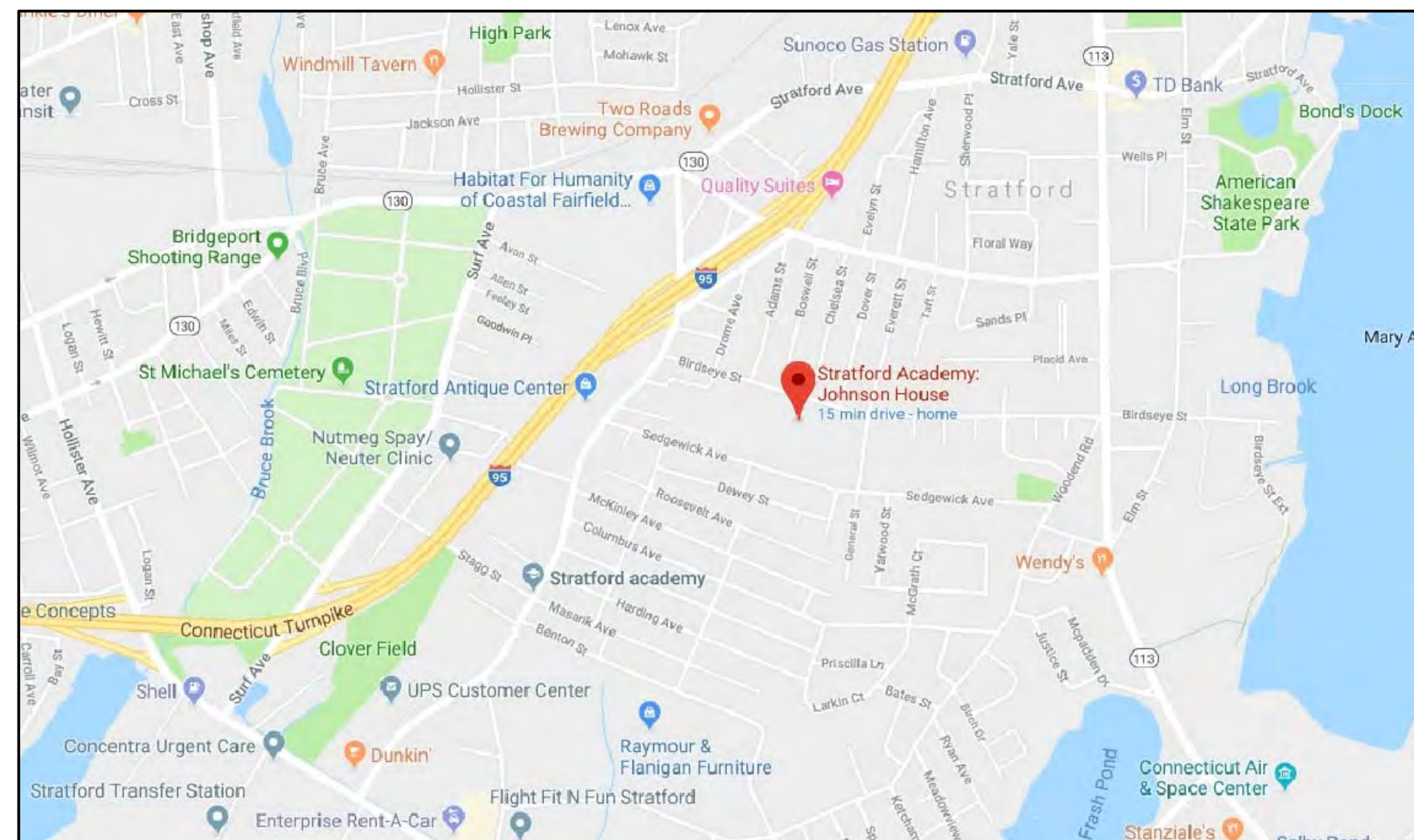

### GENERAL NOTES:

- ALL DETAILS AND/OR PART OF DETAILS ARE SIMILAR FOR SIMILAR LOCATIONS IN ALL OR PART OF THE DETAIL.
- ALL WORK IS NEW UNLESS NOTED OTHERWISE.
- EACH CONTRACTOR SHALL VERIFY ALL CONDITIONS AND DIMENSIONS ON THE JOB SITE.
- INDICATED DIMENSIONS ARE TO :  
A. FACE OF MASONRY OR CONCRETE AND FACE OF FINISH TO FINISH ARE EXACT.  
B. CENTER LINES.
- WRITTEN DIMENSIONS ON THESE DRAWINGS SHALL HAVE PRECEDENCE OVER SCALED DIMENSIONS.
- ANY VARIATION FROM CONDITIONS SHOWN ON THESE DRAWINGS SHALL BE BROUGHT TO THE ATTENTION OF THE CONSTRUCTION MANAGER AND ARCHITECT. AFFECTED WORK SHALL NOT PROCEED UNTIL CLARIFICATION HAS BEEN RECEIVED.
- ALL WORK IS TO CONFORM TO ALL APPLICABLE CONNECTICUT BUILDING CODES.
- USE ONLY NEW MATERIALS AND EQUIPMENT WITHOUT DEFECTS.
- DISCREPANCIES AND OMISSIONS ON DRAWINGS AND SPECIFICATIONS SHALL BE REPORTED TO THE CONSTRUCTION MANAGER AND ARCHITECT IN WRITING FOR CLARIFICATION.
- SET ALL WORK STRAIGHT, PLUMB AND LEVEL OR WITH INDICATED SLOPE.
- EACH CONTRACTOR IS TO USE THE APPROVED STANDARDS: A.I.S.C. FEDERAL, U.S., ETC. STANDARDS OF THEIR TRADES. ALL CONSTRUCTION SHALL BE PERFORMED TO THESE STANDARDS.
- IF AMBIGUITIES EXIST IN THE CONTRACT DOCUMENTS, THE CONTRACTOR SHALL INCLUDE IN HIS BID THE MORE EXPENSIVE METHOD OF WORK.
- THE GENERAL CONTRACTOR SHALL REMOVE AND DISPOSE OF ALL DEBRIS.
- LARGE SCALE DETAILS HAVE PRECEDENCE. HOWEVER WORK INDICATED ON SMALL SCALE DRAWINGS SHALL NOT BE OMITTED. SIMILARLY, NOTES TAKE PRECEDENCE OVER SCHEDULES, PIPING AND WIRE DIAGRAMS. HOWEVER WORK SHOWN OR DESCRIBED BY OTHER METHODS SHALL NOT BE OMITTED.
- CUT AND PATCH ALL EXISTING FINISHES AS REQUIRED BY NEW WORK. MATCH AND FINISH TO PRESENT FINISHED SURFACES OR AS INDICATED.
- FLASH PATCH EXISTING CONCRETE SLABS THAT ARE TO RECEIVE FINISH FLOORING AS REQUIRED.
- ALL PIPING IN FINISHED SPACES TO BE FURRED OUT AND FINISHED TO MATCH EXISTING ADJACENT FINISHES.
- BY SUBMISSION OF THE BID OR PROPOSAL THE UNDERSIGNED BIDDER AND THE PERSON OR PERSONS SIGNING ON BEHALF OF THE BIDDER, AND SHOULD THIS BID BE A JOINT BID, EACH PARTY THERETO, CERTIFIES AS TO ITS OWN ORGANIZATION, UNDER PENALTY OF PERJURY, THAT TO THE BEST OF KNOWLEDGE AND BELIEF:  
  
THE PRICES IN THIS BID HAVE BEEN ARRIVED AT INDEPENDENTLY WITHOUT COLLUSION, CONSULTATION, COMMUNICATION, OR AGREEMENT FOR THE PURPOSE OF RESTRICTING COMPETITION, AS TO ANY MATTER RELATING TO SUCH PRICES WITH ANY OTHER BIDDER OR WITH ANY COMPETITOR.  
  
UNLESS OTHERWISE REQUIRED BY LAW, THE PRICES WHICH HAVE BEEN QUOTED IN THIS BID HAVE NOT BEEN KNOWINGLY DISCLOSED BY THE BIDDER PRIOR TO OPENING, DIRECTLY OR INDIRECTLY, TO ANY OTHER BIDDER NOR TO ANY COMPETITOR; AND NO ATTEMPT HAS BEEN MADE OR WILL BE MADE BY THE BIDDER TO INDUCE ANY OTHER PERSON, PARTNERSHIP OR CORPORATION TO SUBMIT OR NOT TO SUBMIT A BID FOR THE THE PURPOSE OF RESTRICTING COMPETITION.

### LIST OF DRAWINGS

T-101	Title Sheet
A-101	Roof Plan
A-201	Roof Details

### Revisions

3/8/2019	ISSUED
5/22/2019	REVISED PER STATE COMMENTS
6/4/2019	ISSUED FOR BID

### SNYDER ARCHITECTS, LLC

Architecture . Planning . Construction Management  
Trumbull, CT 203-243-3346  
info@snyderarchitects.com

### Roofing Consultant

M.A. CAPUTO ASSOCIATES  
1008 Quinnipiac Avenue  
New Haven, CT 06513  
(203) 469-3216

### Environmental Consultant

AMC ENVIRONMENTAL, LLC  
P.O. Box 423  
Stratford, CT 06615  
(203) 378-5020

### Project



2725 Main Street  
Stratford, CT 06614

Roof Replacement at:  
Stratford Academy - Johnson House

719 Birdseye Street  
Stratford, CT 06615

State Project No. 138-0105 RR

### Drawing Title

Title Sheet

Drawings Formatted for 24"x36" Paper

Issued	6/4/2019	Drawing No. <b>T-101</b>
Scale	AS INDICATED	
Job No.	18-075	

### MATERIALS LEGEND:

	BRICK		STONE
	BATT INSULATION		CRUSHED STONE
	CONTINUOUS WOOD FRAMING THROUGH MEMBER.		CONCRETE MASONRY UNITS
	CONCRETE		NEW PARTITION
	METALS		WOOD FRAMING - INTERRUPTED MEMBER
	PARTICLE BOARD		FINISHED WOOD
	RIGID INSULATION		
	COMPACTED GRAVEL		
	EARTH/UNDISTURBED SOIL		

### GRAPHIC LEGEND:

	INTERIOR WALL ELEVATION NUMBERS		REMOVE EXISTING CONSTRUCTION
	SECTION REFERENCE		EXISTING CONSTRUCTION
	DETAIL REFERENCE		REVISION MARK
	ROOM NUMBER		COLUMN GRID LINES
	CEILING HEIGHT		BUILDING SECTION
	PARTITION TYPE		INDICATES HIDDEN LINE - ABOVE, BELOW, BEHIND OR ITEMS TO BE REMOVED
	EXTERIOR ELEVATIONS		EXISTING DOOR ASSEMBLY
	CENTERLINE OR N.I.C.		EXISTING DOOR TO BE REMOVED
	WINDOW TYPE		DOOR TO BE INSTALLED INDICATES DOOR NUMBER (SEE SCHEDULE)
	HOLLOW METAL TYPE		FURNITURE

NOTE: ROOM NUMBERS DESIGNATED DO NOT CORRESPOND TO EXISTING SCHOOL SIGNAGE & ARE FOR CONSTRUCTION PURPOSE ONLY



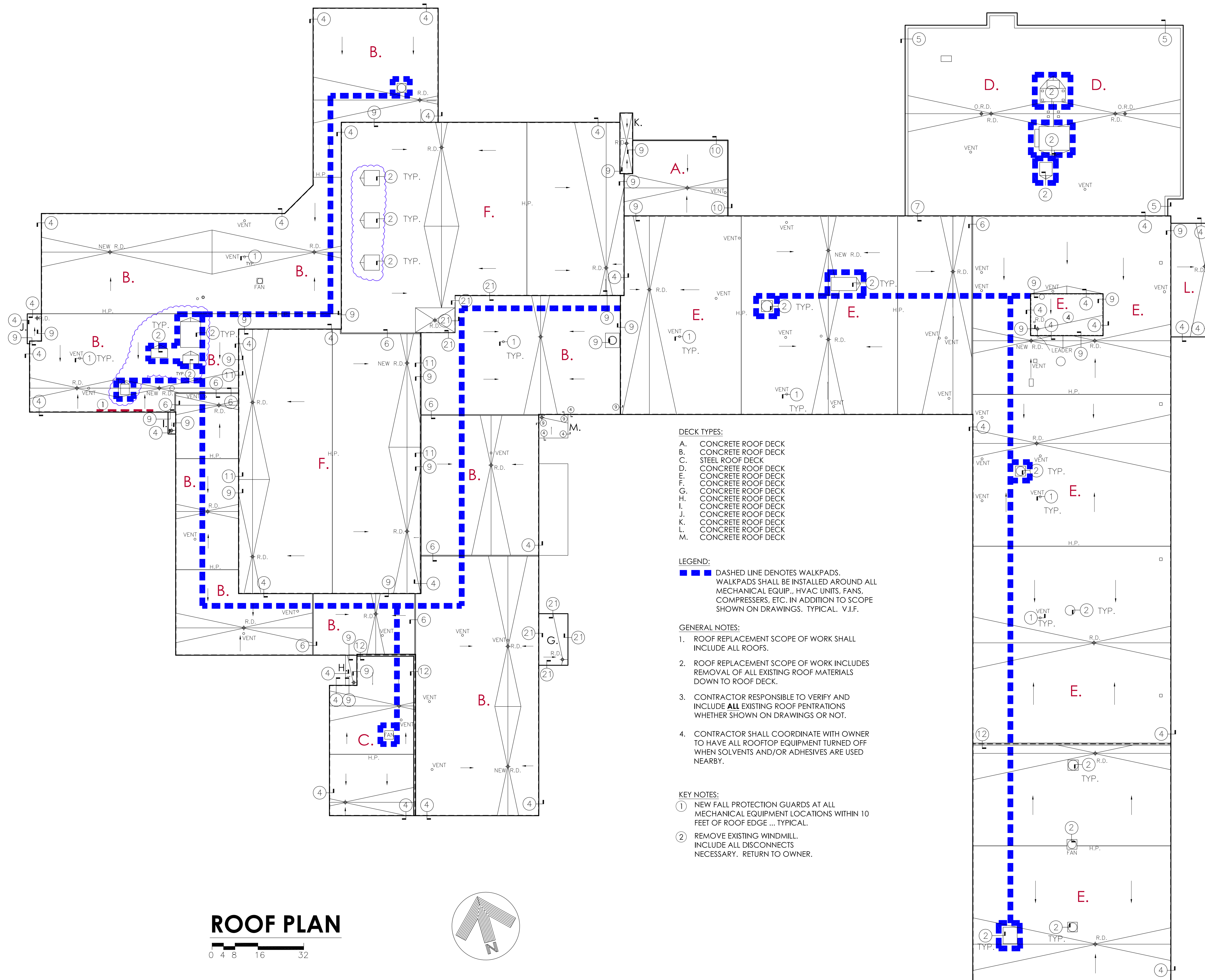

- DECK TYPES:**
- A. CONCRETE ROOF DECK
  - B. CONCRETE ROOF DECK
  - C. STEEL ROOF DECK
  - D. CONCRETE ROOF DECK
  - E. CONCRETE ROOF DECK
  - F. CONCRETE ROOF DECK
  - G. CONCRETE ROOF DECK
  - H. CONCRETE ROOF DECK
  - I. CONCRETE ROOF DECK
  - J. CONCRETE ROOF DECK
  - K. CONCRETE ROOF DECK
  - L. CONCRETE ROOF DECK
  - M. CONCRETE ROOF DECK

**LEGEND:**

■ DASHED LINE DENOTES WALKPADS.  
 WALKPADS SHALL BE INSTALLED AROUND ALL MECHANICAL EQUIP., HVAC UNITS, FANS, COMPRESSERS, ETC. IN ADDITION TO SCOPE SHOWN ON DRAWINGS. TYPICAL. V.I.F.

- GENERAL NOTES:**
1. ROOF REPLACEMENT SCOPE OF WORK SHALL INCLUDE ALL ROOFS.
  2. ROOF REPLACEMENT SCOPE OF WORK INCLUDES REMOVAL OF ALL EXISTING ROOF MATERIALS DOWN TO ROOF DECK.
  3. CONTRACTOR RESPONSIBLE TO VERIFY AND INCLUDE **ALL** EXISTING ROOF PENETRATIONS WHETHER SHOWN ON DRAWINGS OR NOT.
  4. CONTRACTOR SHALL COORDINATE WITH OWNER TO HAVE ALL ROOFTOP EQUIPMENT TURNED OFF WHEN SOLVENTS AND/OR ADHESIVES ARE USED NEARBY.

- KEY NOTES:**
- ① NEW FALL PROTECTION GUARDS AT ALL MECHANICAL EQUIPMENT LOCATIONS WITHIN 10 FEET OF ROOF EDGE ... TYPICAL.
  - ② REMOVE EXISTING WINDMILL. INCLUDE ALL DISCONNECTS NECESSARY. RETURN TO OWNER.

**ROOF PLAN**

0 4 8 16 32

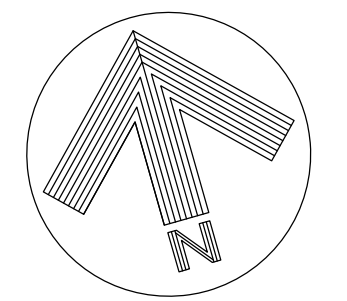

**Revisions**

3/8/2019	ISSUED
5/22/2019	REVISED PER STATE COMMENTS
6/4/2019	ISSUED FOR BID

**SNYDER ARCHITECTS, LLC**  
 Architecture . Planning . Construction Management  
 Trumbull, CT 203-243-3346  
 info@snyderarchitects.com

- **Roofing Consultant**  
 M.A. CAPUTO ASSOCIATES  
 1008 Quinnipiac Avenue  
 New Haven, CT 06513  
 (203) 469-3216
- **Environmental Consultant**  
 AMC ENVIRONMENTAL, LLC  
 P.O. Box 423  
 Stratford, CT 06615  
 (203) 378-5020

**Project**

**TOWN OF STRATFORD**  
 2725 Main Street  
 Stratford, CT 06614

Roof Replacement at:  
**Stratford Academy - Johnson House**  
 719 Birdseye Street  
 Stratford, CT 06615  
 State Project No. 138-0105 RR

**Drawing Title**

**ROOF PLAN**

Drawings Formatted for 24"x36" Paper

Issued	6/4/2019	Drawing No.
Scale	AS INDICATED	<b>A-101</b>
Job No.	18-075	



**NOTES:**

- SUPPLEMENT MECHANICAL CURBS WITH P.T. WOOD BLOCKING TO PROVIDE 8 INCH MINIMUM BASE FLASHING HEIGHTS ABOVE FINISHED ROOF SURFACE. CONTRACTOR SHALL ASSUME SOLE RESPONSIBILITY FOR ALL ELECTRICAL AND MECHANICAL DISCONNECTS, EXTENSIONS AND RECONNECTS.
- CONTRACTOR RESPONSIBLE FOR ALL COSTS ASSOCIATED WITH DAMAGED CONDUIT AND OTHER ITEMS WITH THE SPACE BELOW.

**EXISTING ROOFING ASSEMBLY**

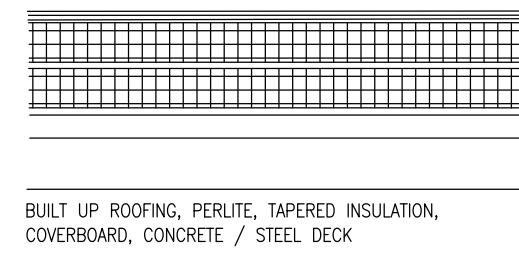

**NEW ROOFING ASSEMBLY**

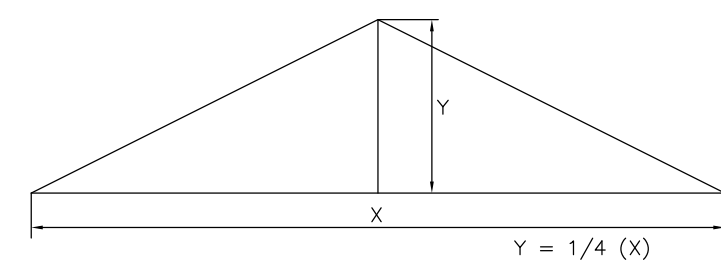
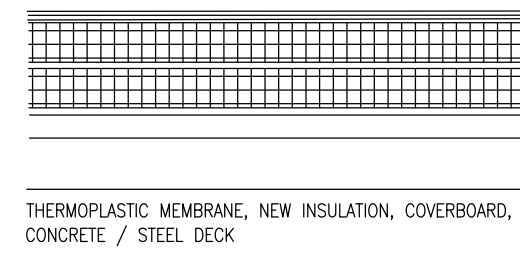

**CRICKET FORMULA**

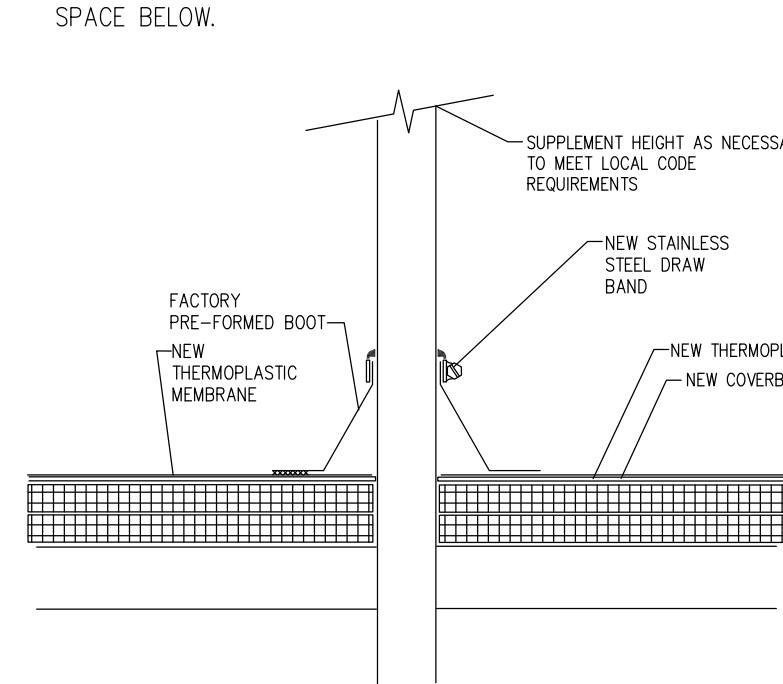

**CHIMNEY / PIPE - DETAIL #1**

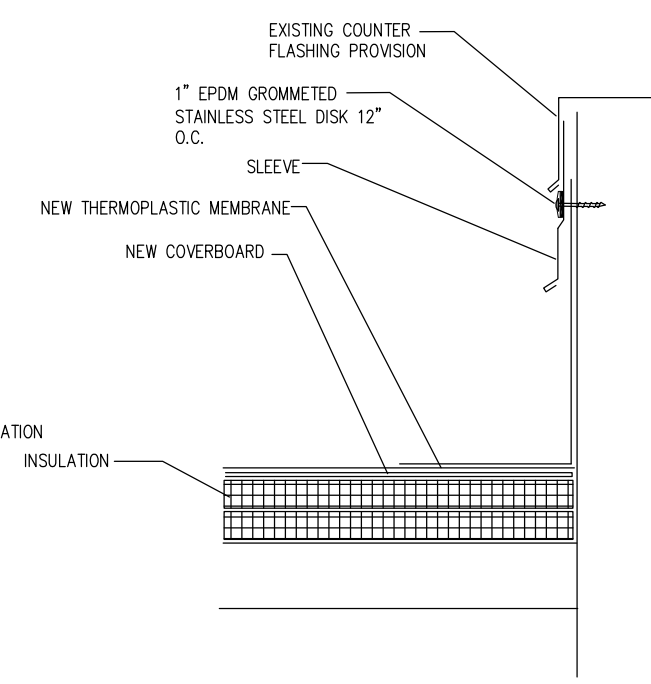

**EXTENDER / SLEEVE- DETAIL #2**

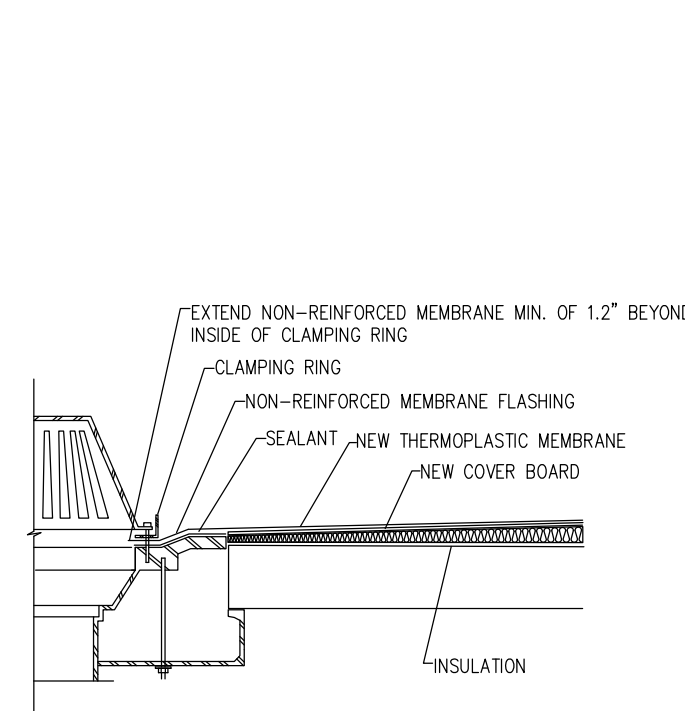

**DRAIN - DETAIL #3**

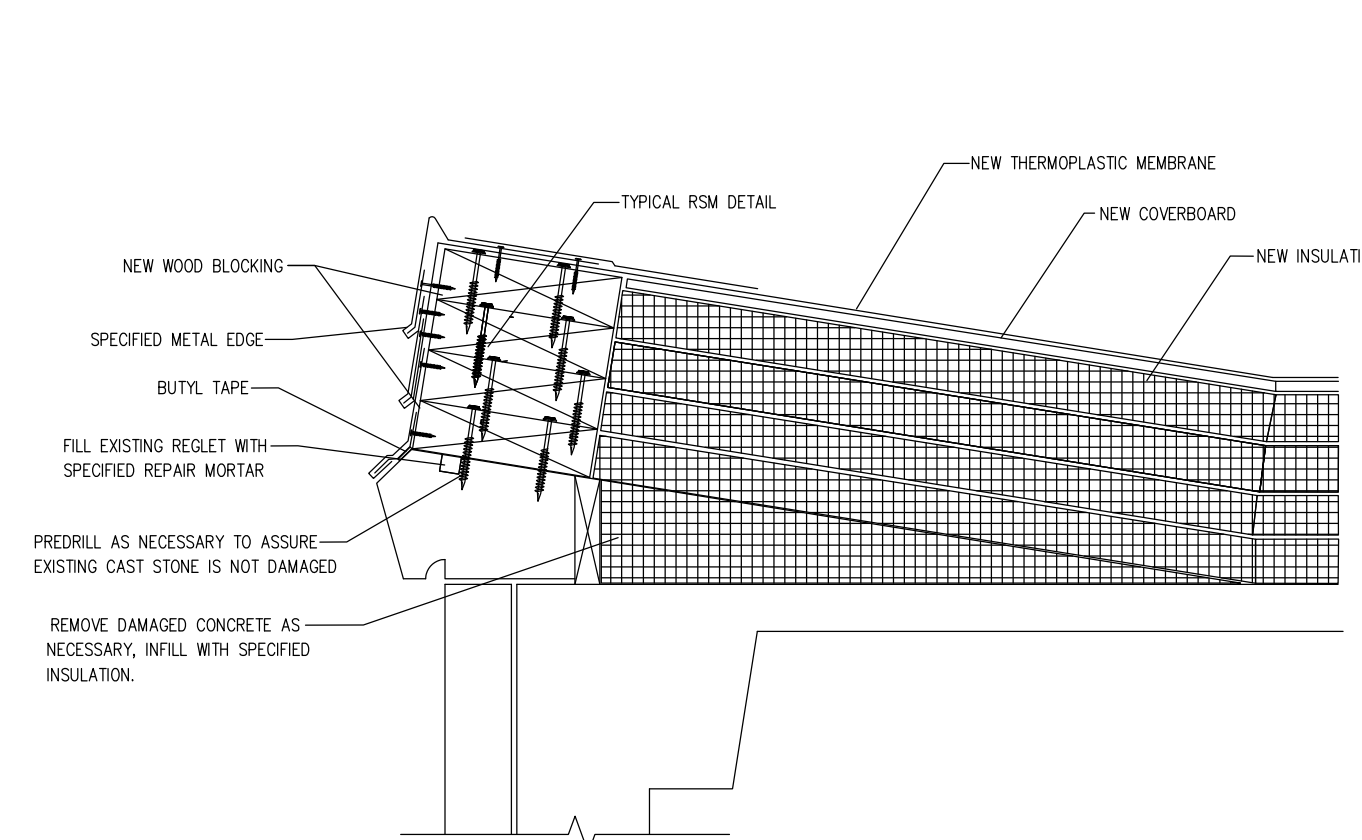

**METAL EDGE - DETAIL #4**

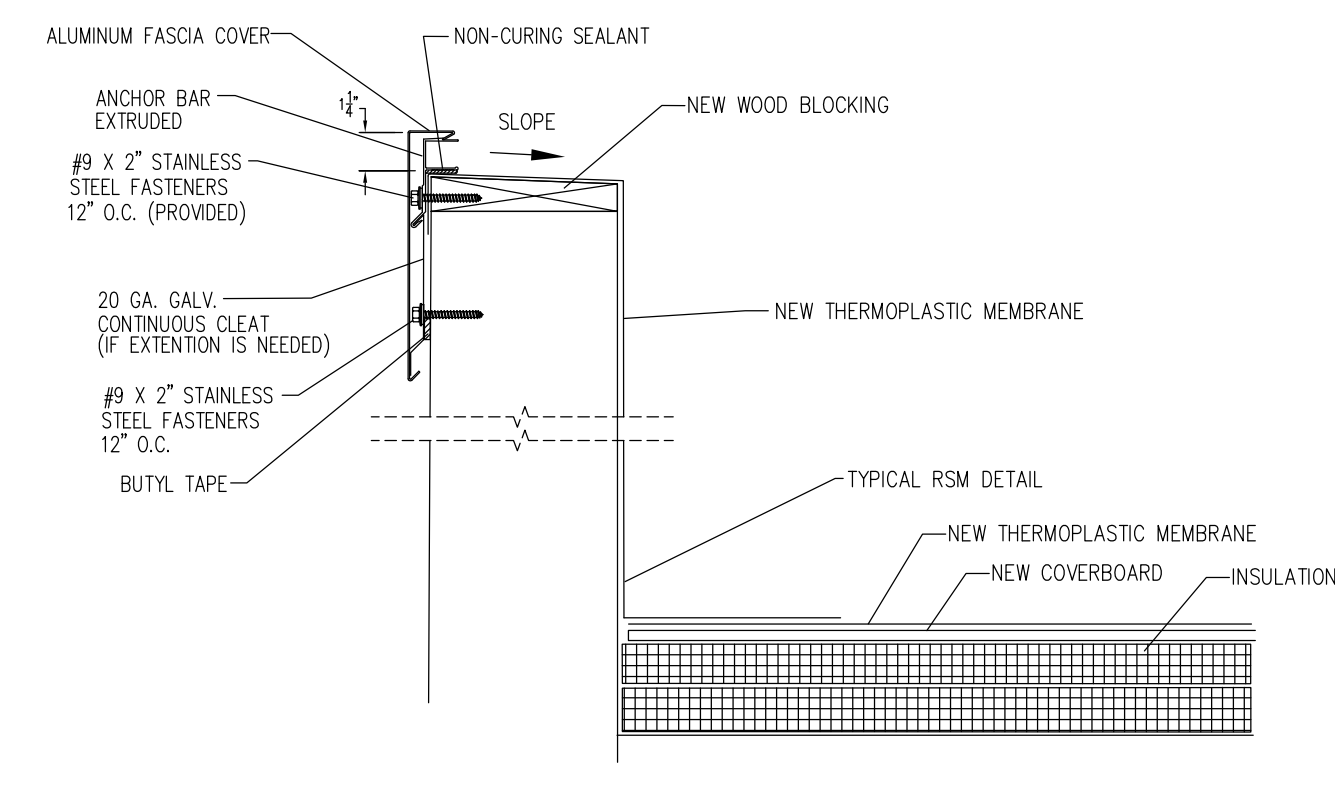

**RAISED METAL EDGE - DETAIL #5**

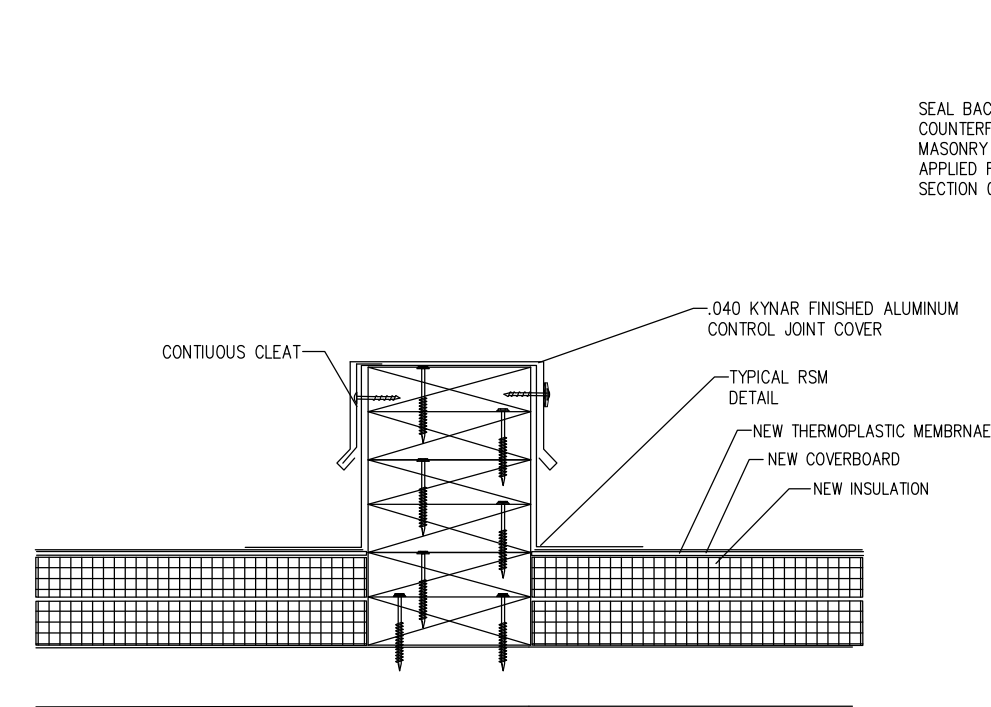

**KNEE WALL - DETAIL #6**

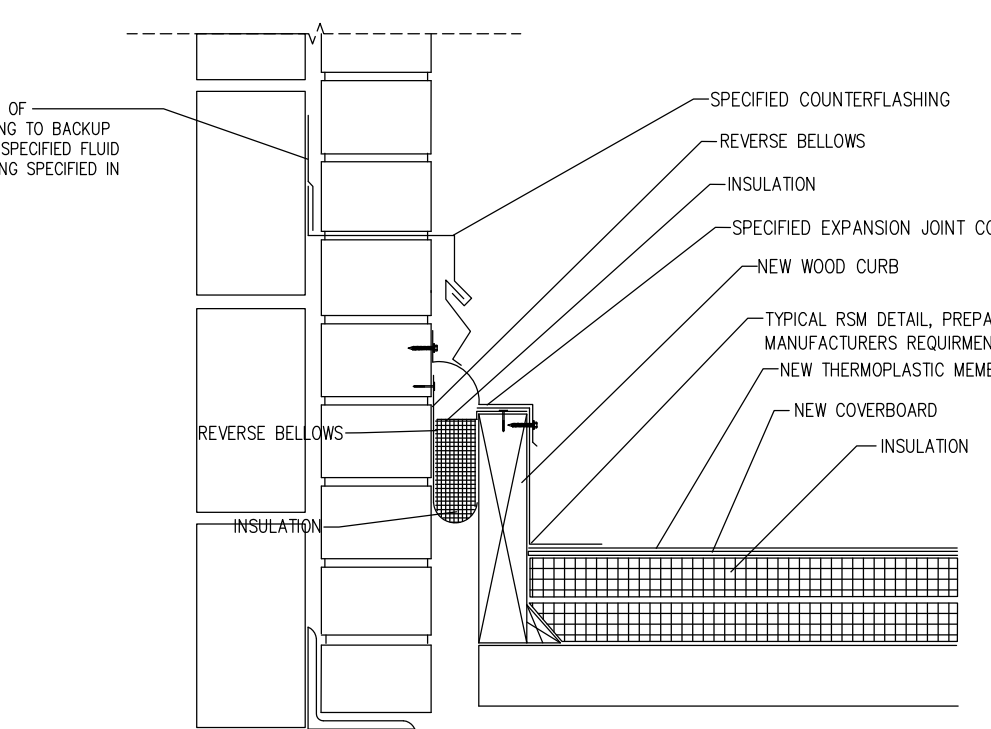

**ROOF TO WALL EXPANSION JOINT - DETAIL #7**

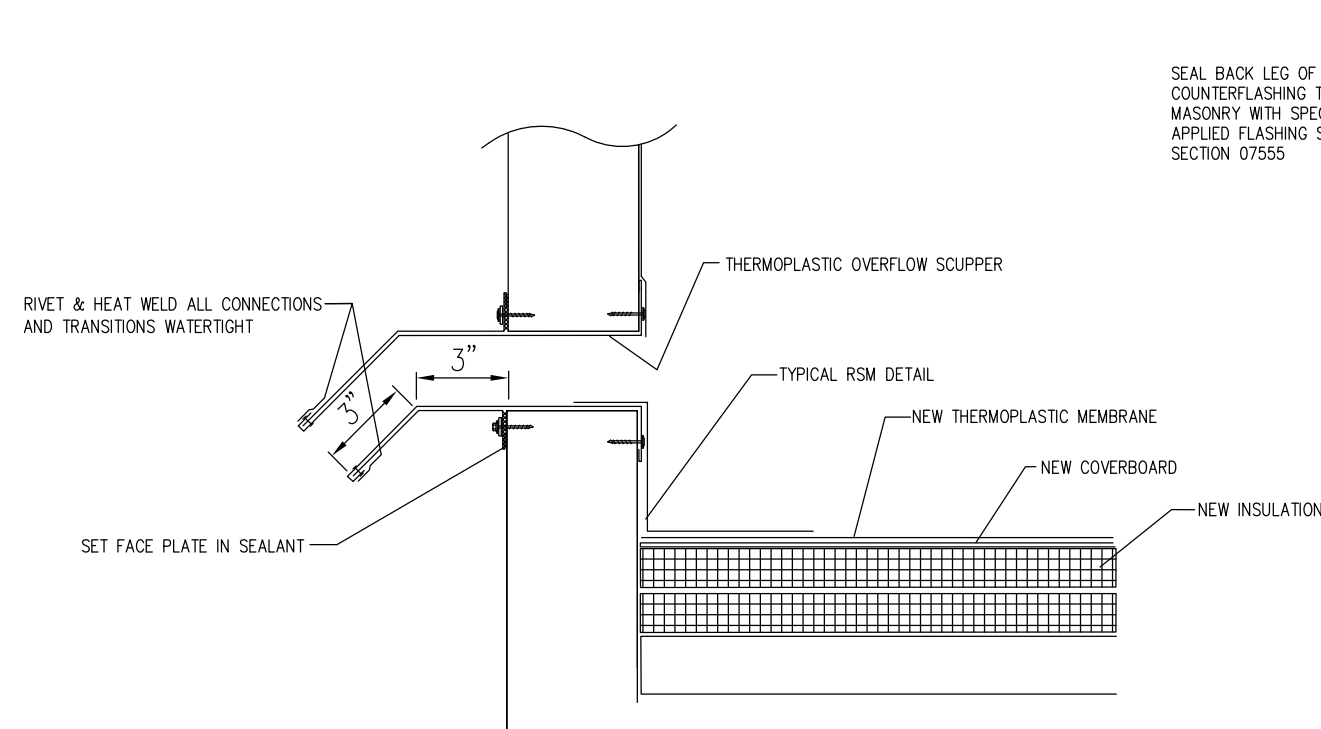

**OVERFLOW SCUPPER - DETAIL #8**

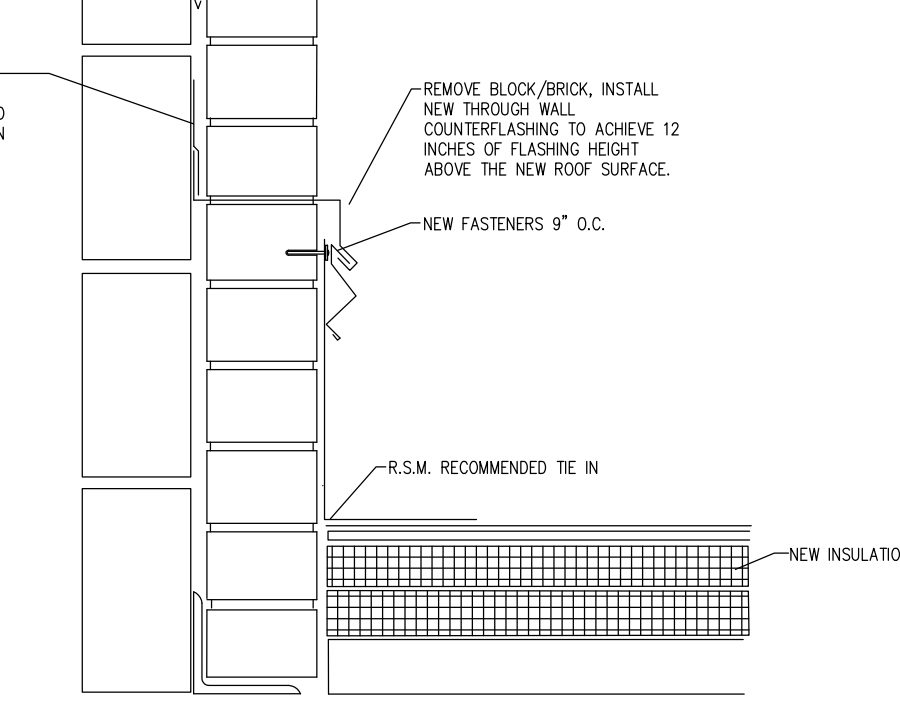

**COUNTERFLASHING - DETAIL #9**

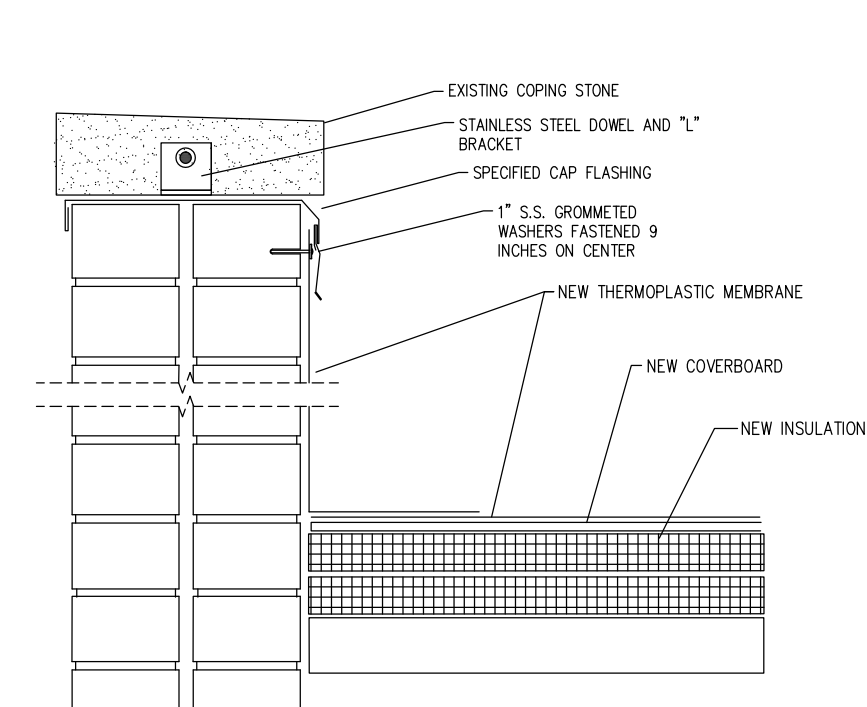

**NEW CAP FLASHING - DETAIL #10**

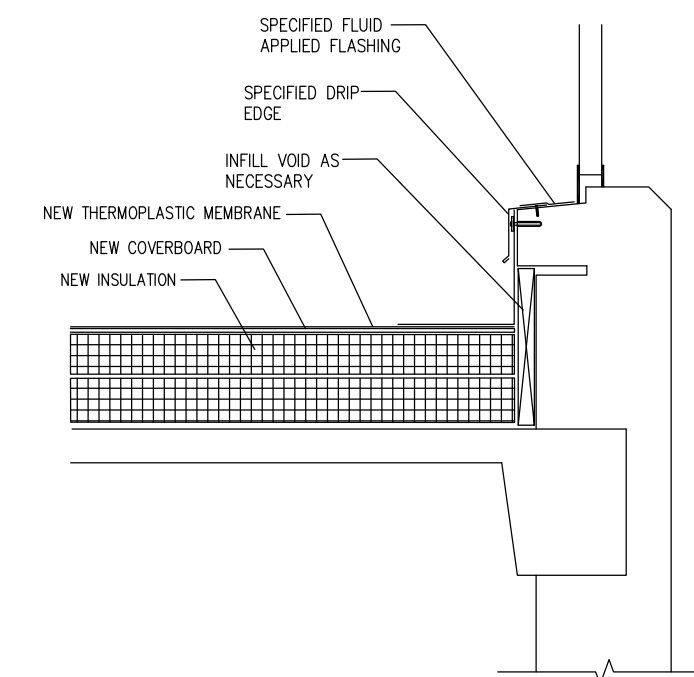

**CORNER CLOSURE - DETAIL #11**

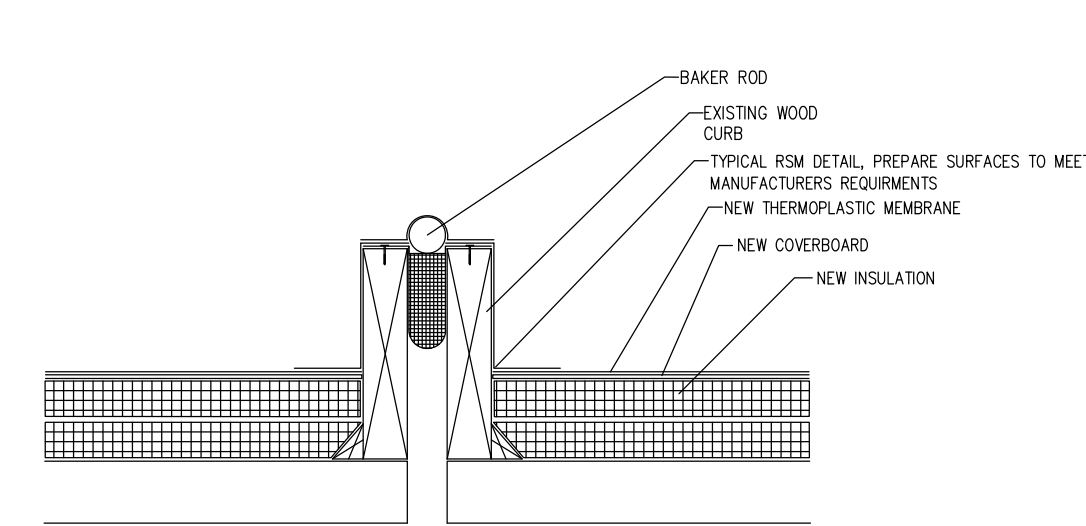

**ROOF TO ROOF EXPANSION JOINT - DETAIL #12**

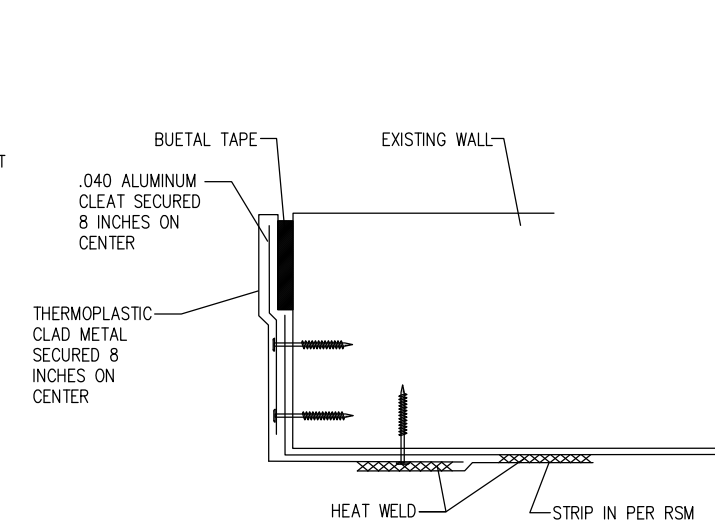

**MEMBRANE TERMINATION - CORNER PLAN DETAIL #13**

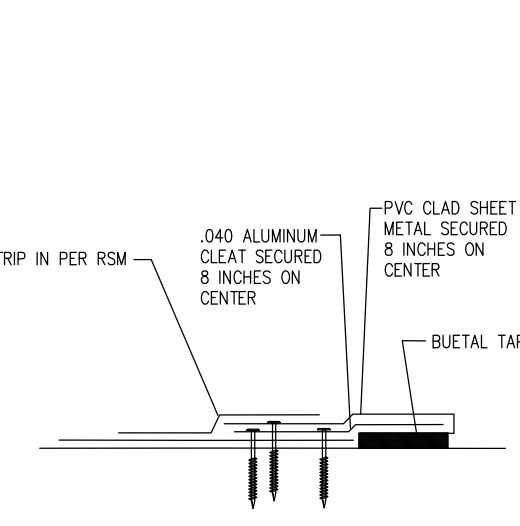

**MEMBRANE TERMINATION PLAN DETAIL #14**

PLAN DETAILS #13 & #14 INDICATE GENERAL VERTICAL MEMBRANE TERMINATIONS. TERMINATION BARS NOT ACCEPTABLE.

**THERMOPLASTIC ROOF DETAILS**

NOT TO SCALE

**Revisions**

3/8/2019	ISSUED
5/22/2019	REVISED PER STATE COMMENTS
6/4/2019	ISSUED FOR BID

**SNYDER ARCHITECTS, LLC**

Architecture . Planning . Construction Management  
Trumbull, CT 203-243-3346  
info@snyderarchitects.com

**Roofing Consultant**

M.A. CAPUTO ASSOCIATES  
1008 Quinnipiac Avenue  
New Haven, CT 06513  
(203) 469-3216

**Environmental Consultant**

AMC ENVIRONMENTAL, LLC  
P.O. Box 423  
Stratford, CT 06615  
(203) 378-5020

**Project**



Roof Replacement at:  
Stratford Academy - Johnson House

719 Birdseye Street  
Stratford, CT 06615

State Project No. 138-0105 RR

**Drawing Title**

**ROOF DETAILS**

Drawings Formatted for 24"x36" Paper

Issued	6/4/2019	Drawing No.
Scale	AS INDICATED	
Job No.	18-075	<b>A-201</b>