

NOTES:

DESIGN AND LOAD CONDITIONS:

VERTICAL LOAD:
 DEAD LOAD SHALL INCLUDE ENTIRE WEIGHT OF FLOATING STRUCTURE, GANGWAY & ANY OTHER ACCESSORIES
 FREEBOARD (UNDER DEAD LOAD): 15"
 FREEBOARD (UNDER DEAD LOAD & 30 PSF UNIFORMLY DISTRIBUTED LIVELOAD): 28"
 LIVELOAD SHALL BE EQUAL TO 30 PSF APPLIED TO THE FULL SURFACE AREA OF DECK

HORIZONTAL LOAD:
 DESIGN TO WITHSTAND STORM CONDITIONS UP TO 1.5' WAVE (PER IBC)

POINT LOAD:
 400 POUNDS AT ANY ONE POINT NOT CLOSER THAN 1 FOOT TO THE EDGE OF DECK SHALL NOT CREATE A DEFLECTION GREATER THAN 2%

WIND LOAD:
 25 POUNDS PER SQUARE FOOT

MATERIALS:

LUMBER:
 SOUTHERN YELLOW PINE, GRADE #1 OR BETTER, S4S KILN DRIED AFTER TREATMENT
 PRESSURE TREATED TO 0.6 #/FT (CCA)

DECK MATERIAL:
 DECK MATERIAL SHALL BE A WOOD POLYMER COMPOSITE (COLOR: GRAY)
 DECKING SHALL BE SECURED TO EACH SUPPORT WITH NOT LESS THAN TWO #12 (MNS)
 STAINLESS STEEL SQUARE DRIVE WOOD SCREWS (LENGTH: 3")
 SPACING BETWEEN THE PLANKS SHALL BE A MAXIMUM OF 1/4"

FLOATATION:
 SHELL SHALL BE HIGH STRENGTH, HIGH DENSITY PREMOULDED POLYETHYLENE
 MINIMUM WALL THICKNESS ON TOP SECTION: 0.100"
 0.250" ON BOTTOM SECTION (WATER CONTACT SURFACE)
 STRESS CRACKING: 800 HOURS F50
 COLOR: BLACK
 FLOATATION FOAM SHALL BE FACTORY PRE-FORMED EXPANDED POLYSTYRENE (EPS) WITH A DENSITY OF 2.10 #/FT³ PRIOR TO THERMO-FORMING PROCESS
 THE NUMBER SIZE OF PONTOONS MAY REQUIRE ADJUSTMENT DEPENDING ON FREEBOARD/LOADING CONDITIONS

STEEL COMPONENTS AND FASTENERS:
 ALL STEEL CONNECTORS, BRACKETS AND MISCELLANEOUS PARTS TO BE FABRICATED FROM ASTM A36 GRADE STEEL
 ALL BOLTS, NUTS & WASHERS SHALL BE FABRICATED ACCORDING TO ASTM A325
 ALL STEEL BOLTS, NUTS, WASHERS AND ANY OTHER HARDWARE SHALL BE HOT DIP GALVANIZED IN ACCORDANCE WITH ASTM A123 AND/OR ASTM A153, UNLESS STATED OTHERWISE
 ALL FASTENERS SHALL HAVE WASHERS, NUTS AND LOCK WASHERS WHERE SPECIFIED

CLEATS:
 CLEATS SHALL BE 10" MALLEABLE CAST IRON

DOCK BUMPER:
 DOCK BUMPER SHALL BE MANUFACTURED WITH A RECESSED TRACK BOTH SIDES TO ACCOMMODATE A ONE-PIECE WASHER LIKE STAINLESS STEEL STRIP FOR FASTENING PURPOSES. STAINLESS STEEL STRIP 5/8" WIDE AND 1/8" THICK SHALL BE PREDRILLED EVERY 2" WITH A 1/4" HOLE.
 DOCK BUMPER SHALL BE FASTENED TO DOCK USING THE STAINLESS STEEL STRIPS AND STAINLESS STEEL PANHEAD SCREWS. DOCK BUMPER SHALL BE INSTALLED VERTICALLY ON RAMP SIDES AND ON END OF WATERWARD DOCK WITH 2-FOOT SPACING. THE LENGTH OF THE DOCK BUMPER SHALL EXTEND TO COVER THE FULL HEIGHT OF THE DOCK FRAMING AND BE PROVIDED WITH TWO (2) 45 DEGREE BEVEL CUTS AT EACH END.

PILE GUIDES:
 HOOPS SHALL BE HDG 2" O SCHEDULE 40 PIPE
 MOUNTING PLATE SHALL BE HDG 1/2" THICK STEEL
 HOOP FASTENING PIPES SHALL BE HDG 1-1/2" SCHED 40 ROLLER SHALL BE 6" LONG UHMW POLYETHYLENE
 FASTENING BRACKET SHALL BE 3/8" HDG STEEL PLATE
 ROLLER ATTACHMENT SHALL BE 3/4" GALVANIZED THREADED ROD, WASHER & NUT WITH NYLON INSERT
 EACH 20' DOCK SECTION SHALL HAVE A MINIMUM OF ONE (1) PILE GUIDE AND THE MOST WATERWARD DOCK SECTION SHALL HAVE AN ADDITIONAL PILE GUIDE INSTALLED ON THE END

GANGWAY RESTING PLATE:
 GANGWAY RESTING PLATE SHALL BE ULTRA HIGH MOLECULAR WEIGHT, HIGH DENSITY POLYETHYLENE GREY (UHMW HOPE PLATE) - 48" x 48" x 1/2"
 PURPOSE: TO REDUCE THE COEFFICIENT OF FRICTION BETWEEN TWO POINTS OF CONTACT AND PROVIDE AN EVEN AREA FOR THE GANGWAY ROLLERS AND THE TRANSITION PLATE TO ROLL ON. GANGWAY RESTING PLATE SHALL BE SECURED TO THE DECK SURFACE WITH #12 STAINLESS STEEL SCREWS. EDGES OF THE RESTING PLATE SHALL BE BEVELLED. EXACT LOCATION OF THE PLATE SHALL BE FIELD DETERMINED

DOCK TO DOCK CONNECTION:
 THE DOCKS SHALL BE SECURED TO ONE ANOTHER WITH TWO MALE/FEMALE PIVOT CONNECTIONS
 THE PIVOT MECHANISM, AS WELL AS THE STRUCTURE, SHALL BE CAPABLE OF WITHSTANDING ALL APPLIED DESIGN LOADS
 THE SPACE BETWEEN THE DOCKS (AT THE DOCK TO DOCK CONNECTIONS) SHALL BE 1/2" MAXIMUM (ACCOMPLISHED BY OVERHANGING DECKING PIECES)

FOR REFERENCE PURPOSES ONLY

STATE OF CONNECTICUT
 DEPARTMENT OF ENERGY
 AND ENVIRONMENTAL PROTECTION
 ENGINEERING AND FIELD SUPPORT SERVICES

ENGINEERING UNIT
 163 GREAT HILL ROAD
 PORTLAND, CONNECTICUT
 PHONE: 860-344-2513
 FAX: 860-344-2560

PROJECT NAME & NUMBER:
 ITB FOR DESIGN AND FABRICATION SERVICES
 FOR STATE BOAT LAUNCH DOCK SYSTEMS

SHEET TITLE:
 DETAILS FOR STANDARD 20' X 8' FLOATING DOCK

DATE	DESCRIPTION	INITIALS

DATE: 2015 DESIGNED: 712 SHEET #: 1/2
 SCALE: NOT TO SCALE DRAWN: DC
 CAD FILE: S712DWZDOCKSDOCK.DWG

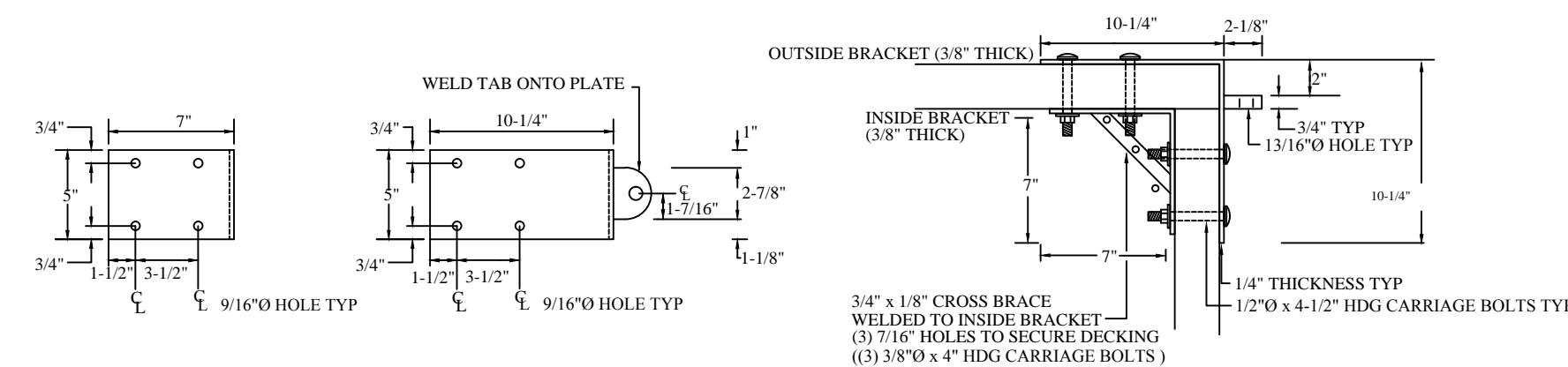

MALE CORNER BRACKET
NOT TO SCALE

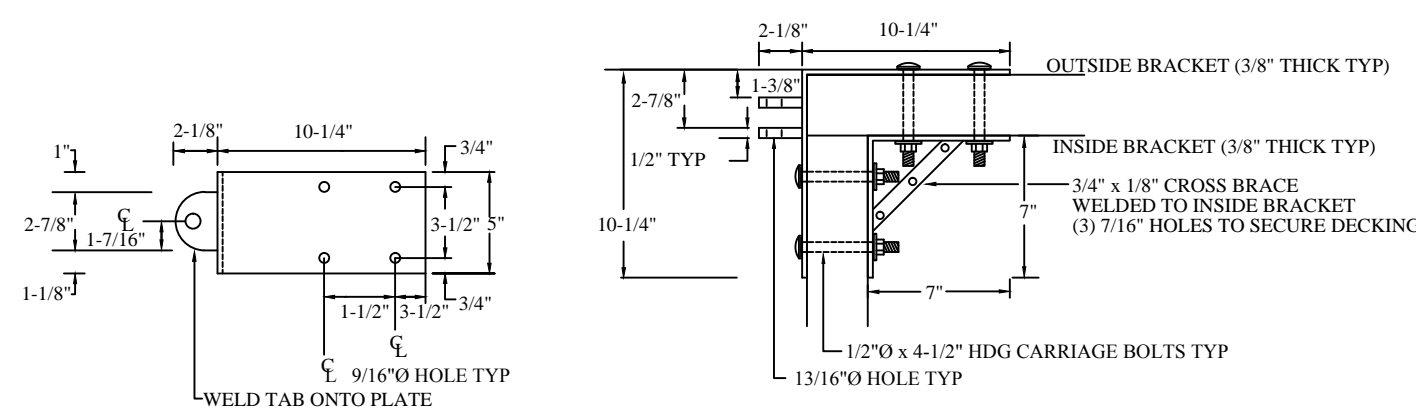

FEMALE CORNER BRACKET
NOT TO SCALE

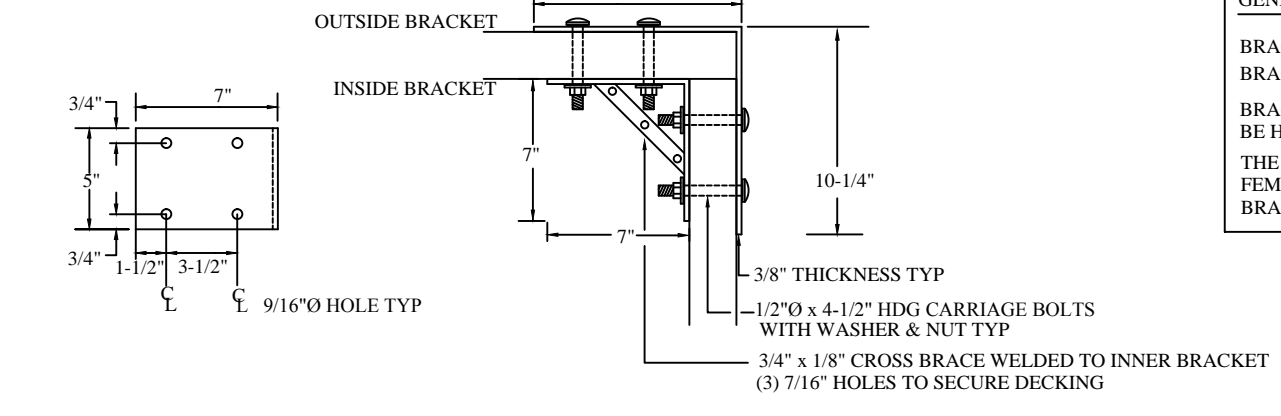

CORNER BRACKET
NOT TO SCALE

GENERAL NOTES FOR ALL CORNER BRACKETS:
BRACKETS SHALL BE READILY AVAILABLE FOR REPLACEMENT. BRACKETS SHALL NOT BE CUSTOMER MADE. BRACKETS (INSIDE AND OUTSIDE) AND ALL FASTENERS SHALL BE HDG. THE INSIDE BRACKETS ARE THE SAME FOR FEMALE AND MALE CORNER BRACKETS AND THE CORNER BRACKETS.

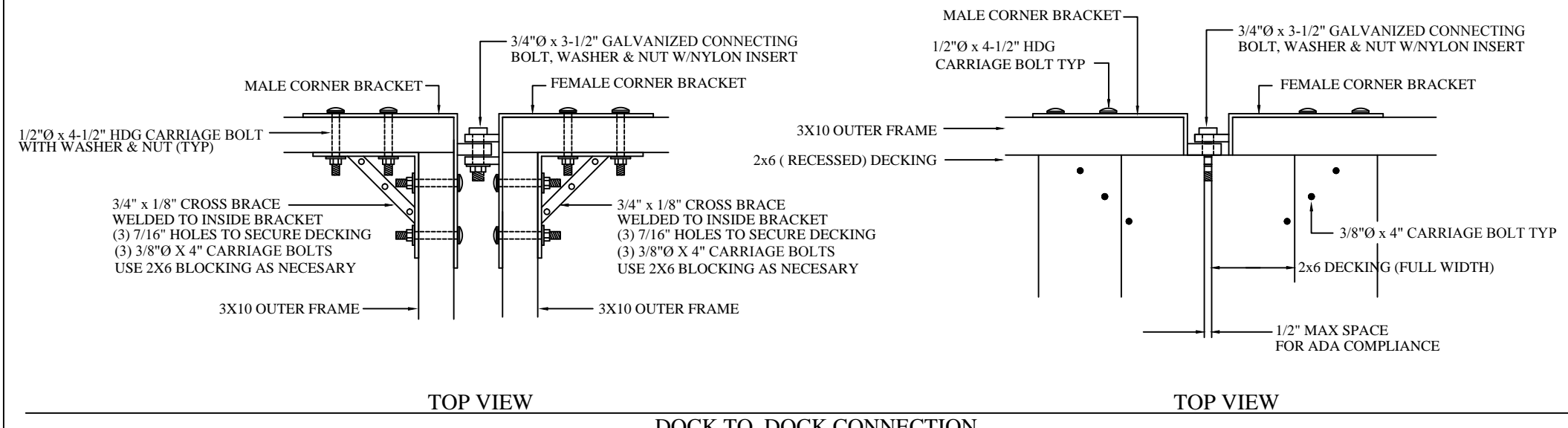

DOCK TO DOCK CONNECTION

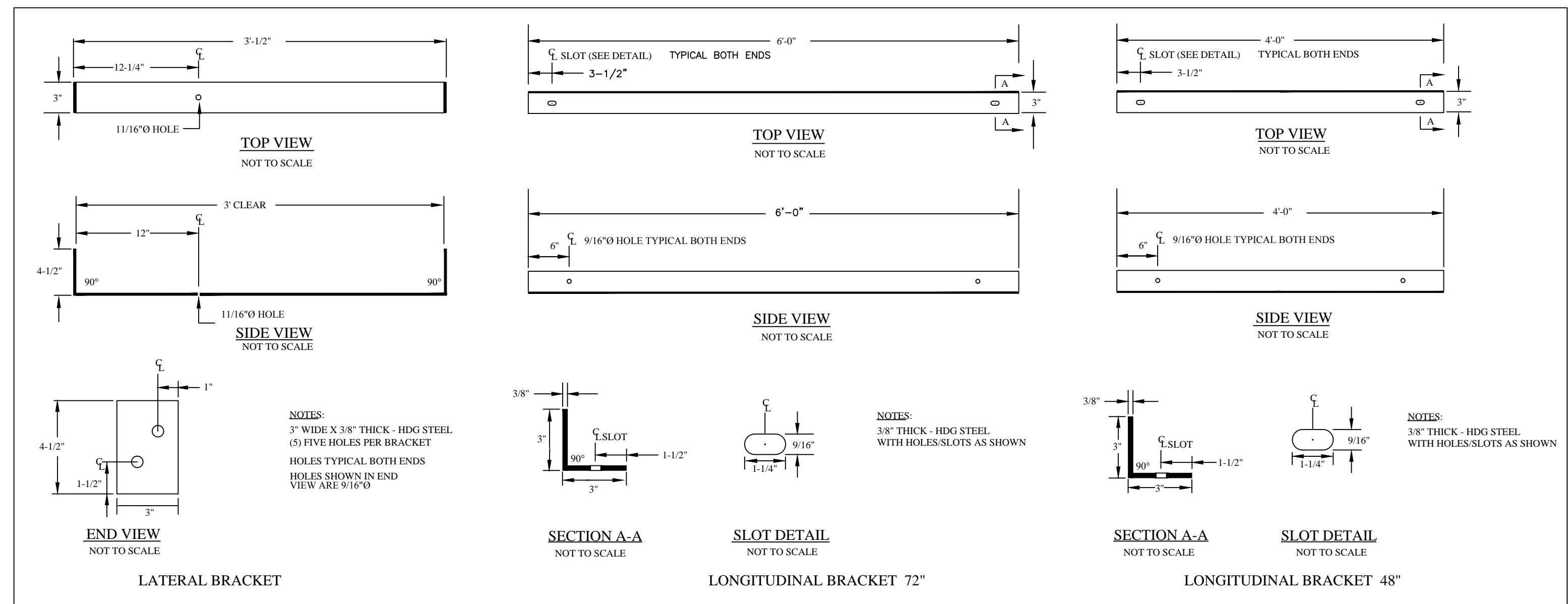

LATERAL BRACKET **LONGITUDINAL BRACKET 72"** **LONGITUDINAL BRACKET 48"**

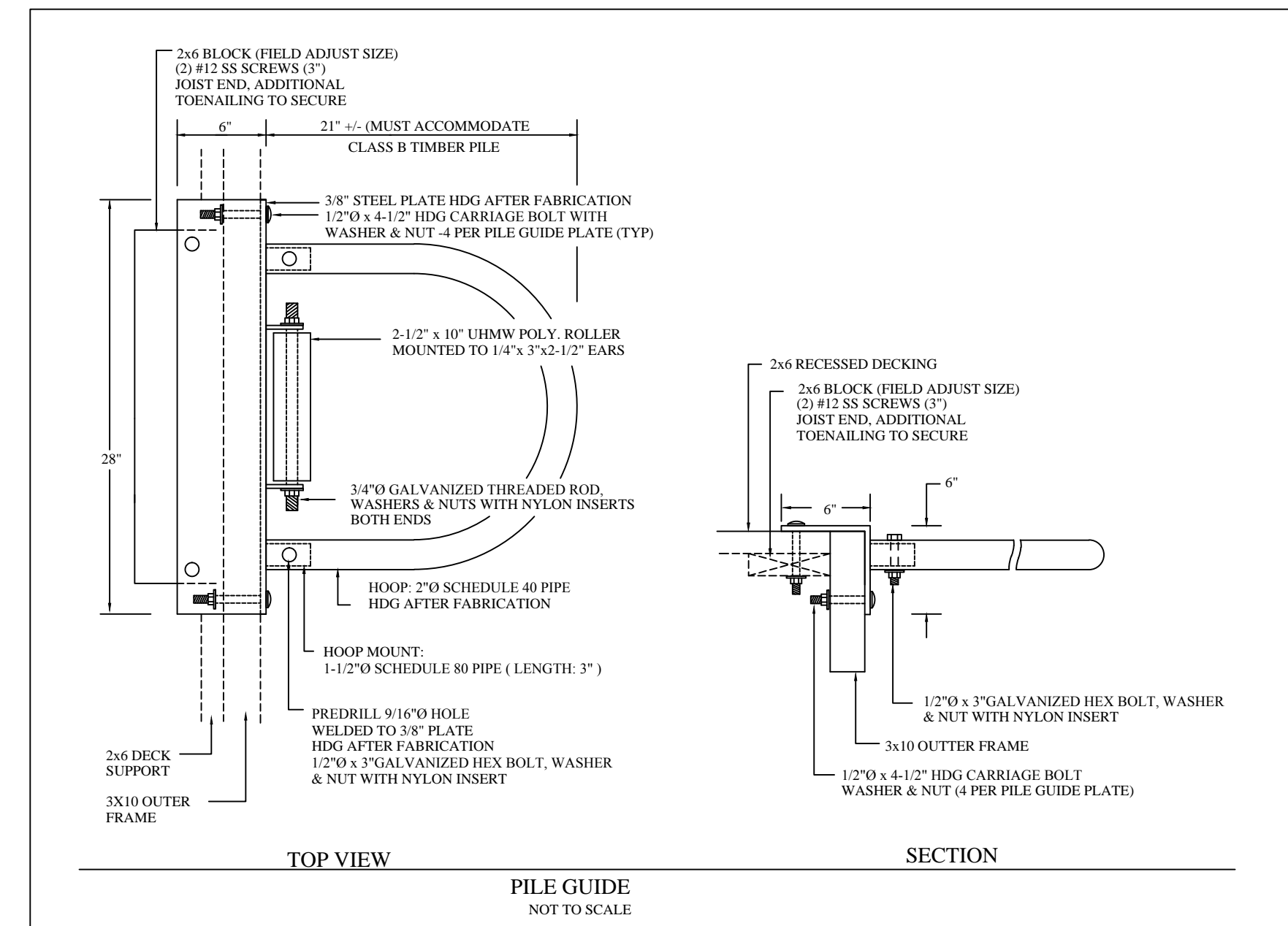

PILE GUIDE
NOT TO SCALE

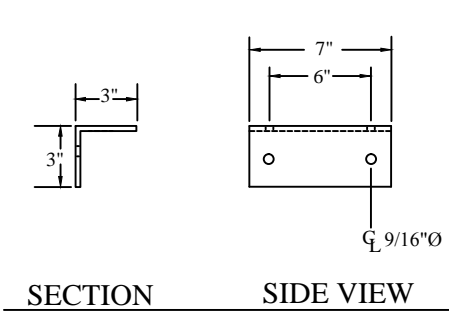

ANGLE BRACKET DETAIL
NOT TO SCALE

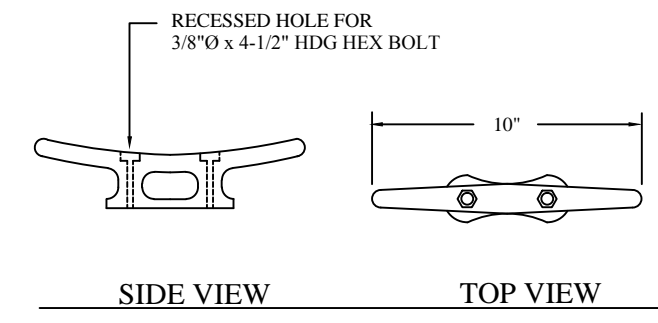

10\"/>

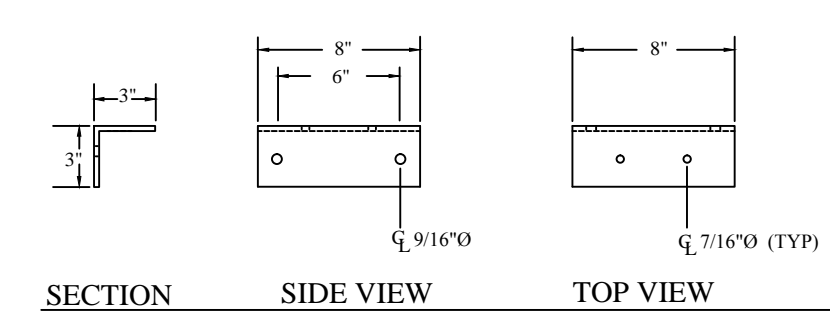

CLEAT BRACKET DETAIL

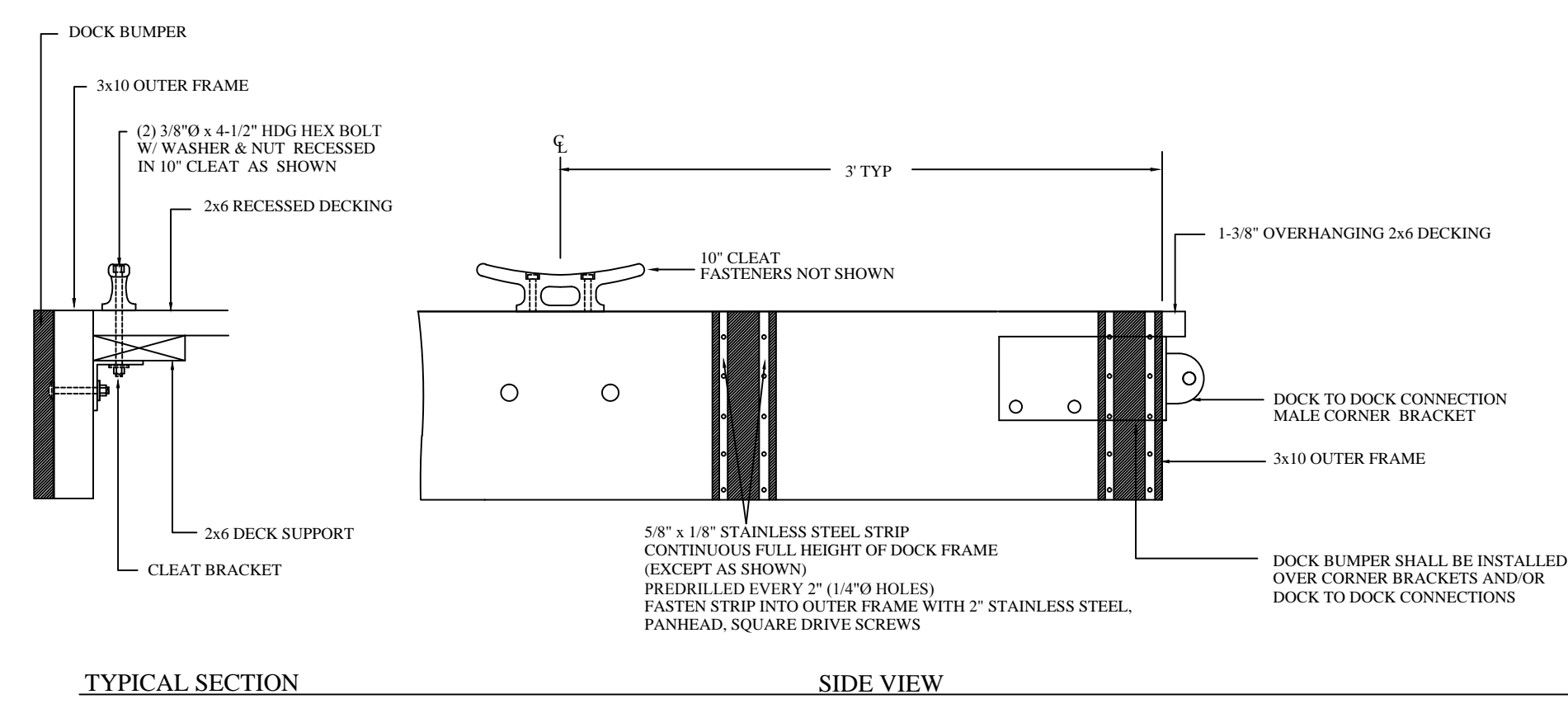

DOCK BUMPER & 10\"/>

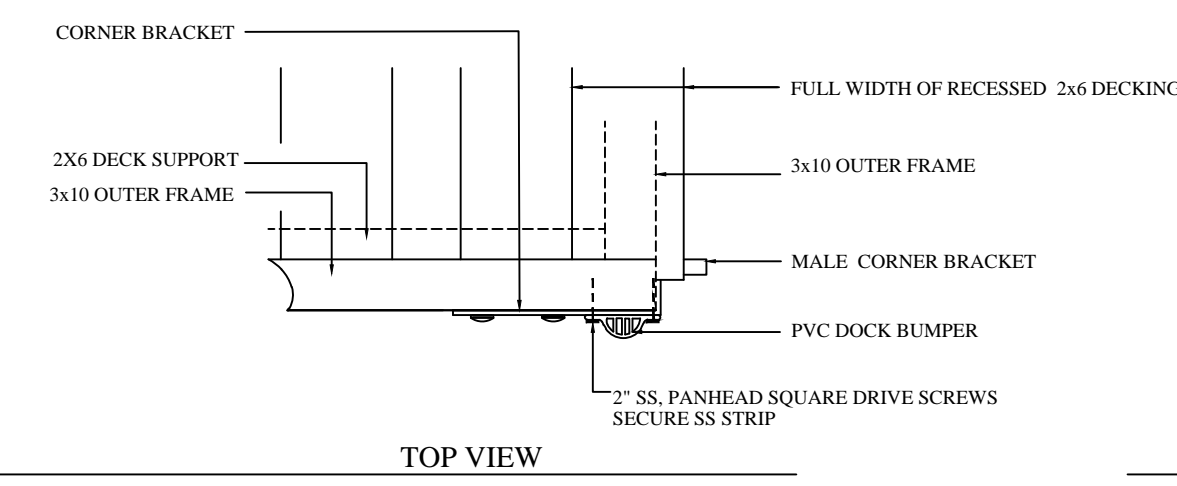

CORNER BRACKET

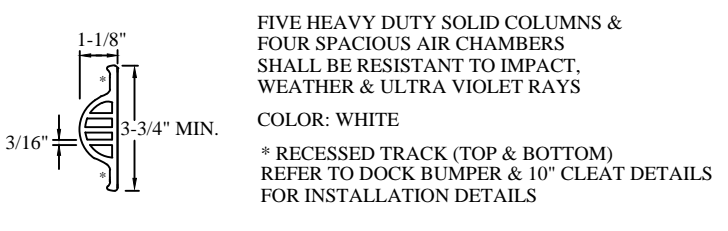

PVC DOCK BUMPER
NOT TO SCALE

FOR REFERENCE PURPOSES ONLY

STATE OF CONNECTICUT DEPARTMENT OF ENERGY AND ENVIRONMENTAL PROTECTION ENGINEERING AND FIELD SUPPORT SERVICES		
ENGINEERING UNIT 163 GREAT HILL ROAD PORTLAND, CONNECTICUT PHONE: 860-344-2513 FAX: 860-344-2560		
PROJECT NAME & NUMBER: ITB FOR DESIGN AND FABRICATION SERVICES FOR STATE BOAT LAUNCH DOCK SYSTEMS		
SHEET TITLE: DETAILS FOR STANDARD 20' X 8' FLOATING DOCK		
REVISIONS		
DATE	DESCRIPTION	INITIALS
DATE: 2018	DESIGNED: 712	SHEET #
SCALE: NOT TO SCALE	DRAWN: DC	2/2
CAD FILE: 8-11-18PWS.DWG		