



Addendum No.: 1

Date Of Addendum: 12/1/2020

CT DAS | Construction Services | Office of Legal Affairs, Policy, and Procurement

Roof & Masonry Replacement Bridgeport Superior Court

1061 Main Street

Bridgeport, CT

BI – JD – 364

Original Bid Due Date / Time:

January 6, 2021

1:00 PM

Previous Addendums: None

TO: Prospective Bid Proposers:

This Addendum forms part of the "Contract Documents" and modifies or clarifies the original "Contract Documents" for this Project dated November 10, 2020. Prospective Bid Proposers **shall** acknowledge receipt of the total number the Addenda issued for this Project on the space provided on Section 00 41 00 Bid Proposal Form.

Failure to acknowledge receipt of the total number the Addenda issued for this Project on the space provided on Section 00 41 00 Bid Proposal Form shall subject Bid Proposers to disqualification.

The following clarifications are applicable to drawings and specifications for the project referenced above.

Item 1:

Contact information for Deborah Levesque to be via email instead of by phone.

00 11 16 Invitation to Bid Contact Person - Deborah Levesque: Deborah.Levesque@jud.ct.gov

01 11 00 Summary of Work; 1.3 G, delete b, Phone and c. Fax. Use d. Email(s): Deborah.Levesque@jud.ct.gov

Item 2:

Contact information for Colliers: add Joseph Luciano.

00 11 16 Invitation to Bid Construction Administration – Joseph Luciano: joseph.luciano@colliers.com

01 11 00 Summary of Work; 1.3 I.d add joseph.luciano@colliers.com

Item 3:

Contact information for OakPark Architects: add Lori Donadio.

00 11 16 Invitation to Bid Architect/Engineer – Lori Donadio: lolid@oakparkarchitects.com

Item 4:

Scope Change:

A-101A: Seventh Floor Library High Ceiling Demolition and RCP

- RCP Demo: (8) locations noted with Hex Note 5B Abatement contractor will remove plaster at pendant light ceiling coffers.
- RCP Revised: (8) locations noted E.1 and G.1, GC to rebuild coffers, see SKA-01 attached.

Item 5:

Scope Clarification:

G-101 Phase floor Plan – 7th Floor

- The abatement contractor will be removing the ceilings, and ceiling mounted equipment. Abatement contractor will install the temporary platform and temporary wall and doors for egress.
- GC to provide temporary direction signs for building occupants and egress.
- Removal of temporary platform by Abatement contractor
- Restoration at temporary egress by GC

AD-101 First & Seventh Floor Demolition – Reflected Ceiling Plans

- Abatement contractor to remove ceilings and ceiling mounted equipment
- Drawing is reference for GC of conditions prior to abatement demo.
- Drawing indicates areas that are to remain or areas where ceiling is being removed and the GC will need to replace after fireproofing.

AD-102 Demolition Roof and Balcony Plans



Addendum No.: 1

Date Of Addendum: 12/1/2020

- By GC including any related abatement scope at the roof
 - A-100 First & Seventh Floor Demolition – Reflected ceiling plans
 - New fireproofing by GC
 - A-101A Seventh Floor Library High Ceiling Demolition and New RCP
 - Containment and demolition by Abatement contractor
 - New ceilings by GC
 - MD-101 Mechanical seventh floor demolition plan
 - Demolition and temporary relocation of diffusers, light fixtures, etc by Abatement contractor
 - ED-101 Seventh Floor Electrical Lighting Demolition Plan
 - Relocation of existing fixtures at temporary locations by Abatement contractor
 - Light fixtures after abatement to be replaced by GC
 - ED-102 Seventh Floor Library Mezzanine Electrical Lighting Demolition Plan
 - Relocation of existing fixtures at temporary locations by Abatement contractor
 - Light fixtures after abatement to be replaced by GC
- All work not reference above by GC

All questions must be **emailed** (not **verbal** or by **phone**) to the consulting Architect/Engineer (Lori L. Donadio, Email: lorid@oakparkarchitects.com) with copies sent to the DAS/CS Project Manager (Steve Udeh, Email: Steven.Udeh@ct.gov) and Construction Manager (Joseph Luciano, Email: joseph.luciano@colliers.com)

End of Addendum 1

Mellanee Walton

**Mellanee Walton, Associate Fiscal Administrative Officer
State of Connecticut
Department of Administrative Services, Construction Services
Office of Legal Affairs, Policy, and Procurement
450 Columbus Boulevard, Suite 1302
Hartford, CT 06103**

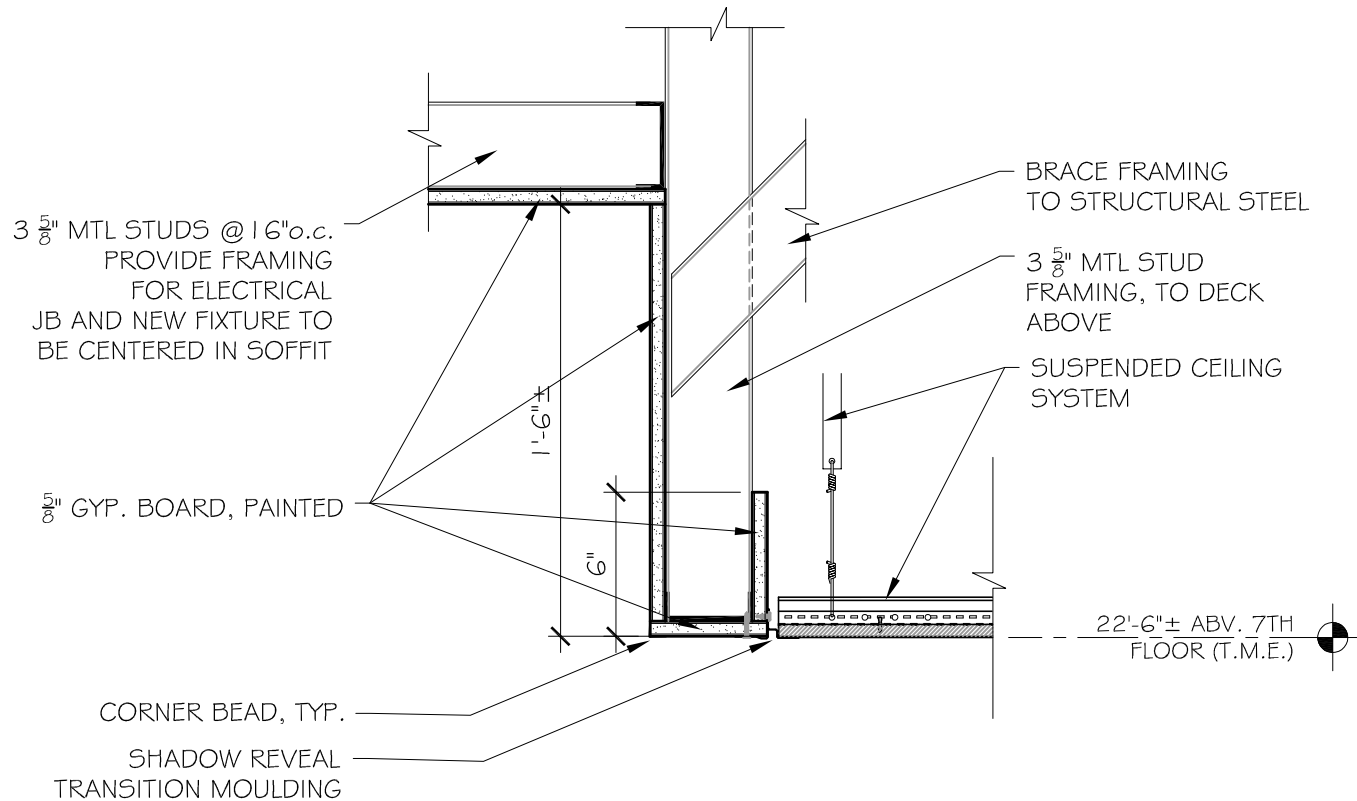

1
SKA-01

LIBRARY SOFFIT DETAIL

SCALE: 1 - 1/2" = 1'-0"

NOVEMBER 25, 2020

SKA-01

DRAWING REF: A-300

LIBRARY SOFFIT
Roof & Masonry Replacement
 Bridgeport Superior Court
 Bridgeport, CT
 Project No. BL-JD-364

OakPark Architects LLC
 312 Park Rd West Hartford CT 06119
 www.opaArch.com 860.232.6664

