

ADDENDUM #2

24 July 2012

RE: Eli Whitney CTHS
Additions & Renovations Project
71 Jones Road
Hamden, CT 06514
Job Nos.: Department of Construction Services – BI-RT-837 / Antinozzi Associates - 04210

FROM: ANTINOZZI ASSOCIATES, P.C.

TO: PROSPECTIVE BIDDERS

Page 1 of 16

This Addendum shall be part of the Contract Documents and modifies the original bidding documents. This Addendum is to be acknowledged by the bidders on the Bid Form. Failure to do so may subject the bidder to disqualification.

Changes to prior Addenda:

- 1) Various items throughout this Addendum.

General Items:

- 1) None.

Clarifications:

- 1) **Question:** *Sheet A-104.1 shows Theory Room D122 without any millwork. The other theory rooms in D-Wing have millwork. Please confirm that no millwork is required for Theory Room D122 as shown on sheet A-104.1.* **Answer:** There is no millwork in Theory Room D122.
- 2) **Question:** *Specification section 084113 calls for a 2 - 1/4" thick thermal door. Should this also apply to the interior aluminum doors? Please clarify* **Answer:** Wherever Aluminum Doors are required at an exterior glazed entry system, the interior vestibule doors shall meet the same specification as the exterior door within the glazed system.
- 3) **Question:** *Sheet A-110.0 includes Roof Demolition Note 15 which indicates to "Remove Existing Cant Curb Enclosure." Please clarify what a cant curb enclosure is and this scope of work. Is the intent to remove the existing parapet framing?* **Answer:** The note simply indicates to remove the existing cant and curb construction around the existing steel beam shown in detail 35/A110.7. The existing metal studs on the high parapet are to remain.
- 4) **Question:** *Sheet S102.1 shows three unidentified connected rectangles drawn between grid line xB-3 and xB-4 and between grid line xB-T and xB-U. What do these three unidentified connected rectangles represent?* **Answer:** They are objects on the architectural background. They are not structural items.

271 Bridgeport Avenue
Bridgeport, CT 06604
Tel: 203.377.1300 Fax: 203.378.3002



ANTINOZZI ASSOCIATES
ARCHITECTURE & INTERIORS

ADDENDUM #2 (continued)

24 July 2012

Eli Whitney CTHS
Additions and Renovations Project

Page 2 of 16

- 5) *The Demolition Drawings, sheet D-101 through D-111, General Demolition Note 8, indicates to disconnect, pack, and place approximately 20 SMART Board systems.*

Question: A. *Please confirm that bidders should include a quantity of 20 SMART Board systems to disconnect, pack, and place as described in the drawings and Scope of Work.* **Answer:** A) Bidders shall include a quantity of 20 smart boards to be disconnected, packed, and placed to be removed as indicated on the drawings.

Question: B. *What are the models and types of existing SMART Board systems that pertain to this work? Are these systems with projectors integral to the screens or are the projectors ceiling mounted separately? Are speakers, inputs and outputs, controls, or other accessories installed separately? Please clarify.*

Answer: B) There are various models and styles of smart boards existing throughout the building. Where ceiling mounted projectors or speakers are separate from the smartboard, the projector and all its accessories including speakers shall be disconnected, packed and placed for shipping. This does not apply to speakers that are not exclusively for the smartboard system.

- 6) **Question: A.** *When will the color schedule be issued? Will it be issued before or after the bid? Have the colors for the RES epoxy resinous flooring been selected as this may affect price?* **Answer:** The specific color selection will be determined after the bid. The full spectrum of colors should be available to choose from.

- 7) **Question: F.** *It appears that information is missing in the Hatch Description legend on sheet FI-101.1, FI-101.2, FI-101.3 and FI-101.4. Please confirm that the Hatch Description legend on sheet FI-101.1, FI-101.2, FI-101.3 and FI-101.4 should be the same as on sheet FI-102.1.* **Answer:** The Legend on FI 101.1, FI-101.2, FI-101.3 and FI 101.4 are all the same, and is exactly the same on sheets FI-102.1, FI-102.2, FI-104.1, FI-104.2, FI-104.3, FI-105.1, and FI-105.2. (Some of the graphic is missing on the first four sheets). The Legend on FI-103.1, FI-103.2, FI-103.3, is also exactly the same except the Terrazzo Legend is added, because the Terrazzo is in Wing C.

- 8) **Question:** *For acoustical ceilings types A-1 and K specification section 095113 calls for Armstrong TechZone. What type of Technical Panels should we include? Should we include Optima to match the 2x4 and 4x4 panels or metal panels perforated or un-perforated?* **Answer:** Ceiling types A-1 and K are Mineral Based Acoustical Panel 24" X 48" and 48" X 48" respectively, as specified, not metal panels.

- 9) **Question: B.** *Sheet A-103.1 indicates that Pot Wash C168A should have 1/4"/ft slope to the drain. Is the slope in the Pot Wash C168A in the concrete or in a thickset floor tile installation? Please confirm that a slope should be included and indicate if slopes to drain throughout the project are in the concrete or through a thickset floor tile installation.* **Answer:** Wherever sloping floors to drain are shown, the slope shall be in the Concrete. Slab.

- 10) **Question: E.** *Please confirm that no slope is required to the floor drain in Dish Room C181 or any other locations throughout the project not clarified above.* **Answer:** No slope-to-drain is required in Dish Room C181.



ADDENDUM #2 (continued)

24 July 2012

Eli Whitney CTHS
Additions and Renovations Project

Page 3 of 16

Changes to Bidding Requirements:

- 1) None.

Changes to Specifications:

PROJECT MANUAL VOLUME 2 OF 3

- 1) Section **08 14 16** – Flush Wood Doors.

a) *The Door Schedule, sheet A-901 through A-903, includes Remark 9 which reads "SEE SPEC SECTION 087112 FOR 'ACOUSTICALLY RATED DOORS'. FURNISH & INSTALL GASKETS @ EA. ACOUSTICALLY RATED DOOR & FRAME." This statement does not appear to be correct as it says to see specification 087112 for acoustically RATED doors and this specification section is for acoustically GASKETED doors. Doors that are acoustically rated and acoustically gasketed are not necessarily mutually exclusive. All of the doors with Remark 9 appear to be wood doors and it is not clear if they should be acoustically rated or gasketed or both. Further, specification section 081416 for Flush Wood Doors includes subsection 2.3, C, which refers to acoustical doors with an STC rating of 42. Specification section 083473, subsection 2.1, G, refers to acoustical doors with an STC rating of 49. The documents do not clearly indicate what doors are to be acoustically rated, acoustically gasketed, and what the STC rating should be for acoustically rated doors.*

Question: *What doors should be acoustically RATED per specification section 081416, FLUSH WOOD DOORS? Should these doors all have an STC rating of 42? Please clarify and update the Door Schedule. **Answer:** Delete paragraph 2.3.C. in its entirety.*

- 2) Section **08 34 73** – Acoustically Rated Doors

a) **Question:** *What doors should be acoustically RATED per specification section 083473, ACOUSTICALLY RATED DOORS? Should these doors all have an STC rating of 49? Please clarify and update the Door Schedule. **Answer:** Reference revised Door Schedule sheets A-901, A-902, and A-903 per Addendum #2.*

- 3) Section **08 71 12** – Acoustically Gasketed Doors

a) **Question:** *C. What doors should be acoustically GASKETED per specification section 087112, ACOUSTICALLY GASKETED DOORS? Please clarify and update the Door Schedule. **Answer:** Reference revised Door Schedule sheets A-901, A-902, and A-903 per Addendum #2.*

- b) Delete Paragraph 2.2.C. in its entirety.



ADDENDUM #2 (continued)

24 July 2012

Eli Whitney CTHS
Additions and Renovations Project

Page 4 of 16

4) Section 09 84 13 – Acoustical Panels

- a) **Question:** *What fabric should be used for the acoustical wall panels type AP-1, AP-2, AP-3 and sound absorptive ceiling material specified in section 098413? What fabric should be used for the acoustical ceiling panels?* **Answer:** Insert the following paragraph, “2.3 Fabric: Guilford of Maine – FR 101.”

5) Section 10 21 00 – Cubicles

- a) **Question:** *A. Specification section 102100, subsection 2.1, 1, indicates the cubicles should use Coral of Chicago's fabrics from book CPQ - 71/2 collection; however, this has been discontinued. Please update this reference to a current product or line as the prices of fabrics can range significantly.* **Answer:** Delete the following in paragraph 2.1.1 “Coral of Chicago. Full range of fabrics from book CPQ - 71/2 Collection,” and insert the following in lieu thereof, “Designtex. Style: Mid Town. Full Range of colors.”
- b) **Question:** *B. Specification section 102100, subsection 2.3, A, references Arc - Com Fabrics, Inc., Series Tea Garden, No. AC-32620; however, this has been discontinued. Please update this reference to a current product or line and coordinate the fabric between the various subsections in this specification section.* **Answer:** Delete the following in paragraph 2.3.A “Arc - Com Fabrics, Inc., Series Tea Garden, No. AC-32620,” and insert the following in lieu thereof, “Designtex. Style: Mid-Town.”

PROJECT MANUAL VOLUME 3 OF 3

- 1) Section 220000: In addition to the above, the entire section is to be replaced with revised section, to include the following:
- a) Change reference in 1.01.6 from “2.2 A, B, C, D, E, F, and G” to “2.01”.
 - b) 2.01 Pipe Materials, 15: Added Domestic CW piping over 4”size.
 - c) 2.08 Plumbing Fixtures, 22: Deleted Temporary Surgical Sink.
 - d) 2.12 Misc. Plumbing Specialties, 14: Revised Waste Oil Storage Tank spec .
 - e) Change reference in 3.03 from “Division 16” to “Division 26” – 2 cases..
- 2) Section 230000: Change reference in 1.01.5 from “2.2 A, B, C, D, E, F, and G” to “2.01”.
- 3) Section 230000: Change reference in 2.01.4 from “2.1 B, C” to “2.01.2, .3”.
- 4) Section 230513: Change reference in 1.01.2 from “2.2 A, B, C, D, E, F, and G” to “2.01”.
- 5) Section 230523: Change reference in 1.01.2 from “2.2 A, B, C, D, E, F, and G” to “2.01”.
- 6) Section 230523: Change reference in 2.03.1 under Condenser Water Supply and Return Piping from “schedule 40” to “Extra Strong (XS)”. Change reference in 2.03.1 under Condenser Water Supply and Return Fittings from “Class 300” to “Extra Strong (XS)”.

271 Bridgeport Avenue
Bridgeport, CT 06604
Tel: 203.377.1300 Fax: 203.378.3002



ANTINOZZI ASSOCIATES
ARCHITECTURE & INTERIORS

ADDENDUM #2 (continued)

24 July 2012

Eli Whitney CTHS
Additions and Renovations Project

Page 5 of 16

- 7) Section 230523: Delete Paragraph 3.02.2 in its entirety, and substitute the following:
- a) Piping installed in existing buildings (or in new buildings where additional supports are required), shall be hung from supplemental steel attached to and spanning the existing (or new, in new buildings) steel structure or as noted below. Where vertical support into masonry or concrete structure cannot be avoided, use supplemental steel as noted above, or vertical anchors rated for seismic and cracked concrete application, similar to:
 - i) Hilti torque-controlled expansion anchor, carbon steel, 304SS or 316 SS to match angle and rod material, or
 - ii) Hilti KWIK HUS EZ-1 3/8" internally threaded screw anchor.
 - iii) Vertical anchors shall be spaced so that maximum operating weight on any individual anchor is one-quarter of the manufacturer's published pullout resistance for cracked 2500 psi concrete for the anchor's diameter and embedment.
- 8) Section 230923: Change reference in 1.01.2 from "2.2 A, B, C, D, E, F, and G" to "2.01".
- 9) Section 230923: Change reference in 1.01.4 from "Division 50" to "Division 019000" – 2 cases.
- 10) Section 230923: Change reference in 2.01.4 from "230923 2.0 B, C" to "230000 2.01".
- 11) Section 230923: Change reference in 2.03.1 from "2.2 B through 2.2 I" to "2.03.2 through 2.03.9".
- 12) Section 230923: Delete reference in 3.33 to "SUPPLEMENTAL BID".
- 13) Section 232500: Change reference in 1.01.2 from "2.2 A, B, C, D, E, F, and G" to "2.01".
- 14) Section 233000: Change reference in 1.01.2 from "2.2 A, B, C, D, E, F, and G" to "2.01".
- 15) Section 235000: Change reference in 1.01.2 from "2.2 A, B, C, D, E, F, and G" to "2.01".
- 16) Section 235000: add the following at end of first sentence in 3.02.1: "from date of acceptance as required by Section 230000, 1.13."
- 17) Section 235000: Renumber paragraphs in 3.03 from "3, 4 and 5" to "1, 2 and 3."
- 18) Section 235000: In newly renumbered Paragraph 3.03.1, delete "3.02 of this specification" and replace with "230000, 3.02"
- 19) Section 235000: In newly renumbered Paragraph 3.03.2, delete "3.2 of this specification" and replace with "230000, 3.02"
- 20) Section 236000: Change reference in 1.01.2 from "2.2 A, B, C, D, E, F, and G" to "2.01".



ADDENDUM #2 (continued)

24 July 2012

Eli Whitney CTHS
Additions and Renovations Project

Page 6 of 16

21) Section 237000: The entire section is to be replaced with revised section, to include the following:

- a) Change reference in 1.01.2 from “2.2 A, B, C, D, E, F, and G” to “2.01”.
- b) Added abort damper and fire damper.
- c) Added sub section 2.29 “Spark Arrestance System (Dust Collection System)

22) Section 260500 – Basic Materials

- a) Replace paragraph 2.06.8.h with the following:
 - i) h. Poured-in-place floor boxes located in new slabs and chopped into existing slabs shown on drawings and specifically drawings E-103.2, E-105.1 and E-105.2 shall be provided in types as follows:

Label	Shape	Trim/Cover	Outlets	Description
Type 1	Square	Aluminum-AL	Two duplex receptacles and data. Provide with FPCTC** flanged cutout cover assembly for carpet/tile installation. Provide with FPBT.	Multi-service box for installation in new or chopped concrete slabs. Wiremold/Walker Series RFB4-CI. (3 7/16”D max.) Provide RFB4-SS series for shallow floors (2-7/16”D max.) Provide cast iron (CI) for slab on grade or wet locations unless otherwise noted.
Type 2	Square	Aluminum-AL	Power and data. Provide with FPFFTC flanged cover assembly for carpet/tile installation. Provide with FPFFT.	Multi-service furniture feed box for installation in new or chopped concrete slabs. Wiremold/Walker Series RFB4CI. (3-7/16”D max.) Provide RFB4-SS series for shallow floors (2-7/16”D max.) Provide cast iron (CI) for slab on grade or wet locations unless otherwise noted.

23) Section 260500 – Basic Materials

- a) Add the following paragraph:
 - i) Poke-thru floor boxes located in existing suspended slabs shown on drawings and specifically drawings E-102.3, E-102.2 and E-102.2 shall be provided in types as follows:



ADDENDUM #2 (continued)

24 July 2012

Eli Whitney CTHS
Additions and Renovations Project

Page 7 of 16

Label	Shape	Trim/Cover	Outlets	Description
Type 1P	Round	Anodized Aluminum	One 20 amp duplex receptacle and four data ports with thread-in (TC) cover, drop-in (DC) cover, hinged cover (HC) as required.	Completely-flush poke-thru power/data outlet for existing concrete floors. Does not require access from below for wiring connections. NOCOM Multiconnect #MOI-DP-COMM4. (4" round hole max.)
Type 2P	Round	Anodized Aluminum	Two 20 amp duplex receptacles and four data ports with thread-in (TC) cover, drop-in	Completely-flush poke-thru power/data outlet for existing concrete floors. Does not require access from below for wiring connections. NOCOM Multiconnect
Type 3P	Round	Anodized Aluminum	Four 20 amp receptacles with thread-in (TC) cover, drop-in (DC) cover, hinged cover (HC) as required.	Completely-flush poke-thru power outlet for existing concrete floors. Does not require access from below for wiring connections. NOCOM Multiconnect #MOI-PWR-4. (4" round hole max.)

24) Section 262200 – Dry Type Transformers

- a) Paragraph 2.02.1; Add the following paragraph:
 - i) d. General Electric

25) Section 262413 – Switchboards

- a) Paragraph 2.04.1; Add the following paragraph:
 - i) d. General Electric

26) Section 262200 – Panelboards

- a) Paragraph 2.03.1; Add the following paragraph:
 - i) d. General Electric

27) Section 275123 – Intercommunication System

- a) Paragraph 2.08.2; revise 'as identified as "CP" on plans' to read 'as identified as "CPI" on plans'.
- b) Paragraph 2.08.2; revise 'shall be manufactured by Cowell Manufacturing Company' to read 'shall be manufactured by Lowell Manufacturing Company'.
- c) Paragraph 2.13.2; revise 'Provide 4 Soundsphere 2212-1 speakers' to read 'Provide 4 Soundsphere 2212-1 speakers or approved equal'.

271 Bridgeport Avenue
Bridgeport, CT 06604
Tel: 203.377.1300 Fax: 203.378.3002



ANTINOZZI ASSOCIATES
ARCHITECTURE & INTERIORS

ADDENDUM #2 (continued)

24 July 2012

Eli Whitney CTHS
Additions and Renovations Project

Page 8 of 16

- d) Paragraph 2.14.2; revise 'Provide 12 Soundsphere 2212-1 speakers' to read 'Provide 12 Soundsphere 2212-1 speakers or approved equal'.
- e) Paragraph 2.15.2; revise 'Provide 12 Soundsphere 2212-1 speakers' to read 'Provide 12 Soundsphere 2212-1 speakers or approved equal'.
- f) Paragraph 2.17.2; revise 'Provide 4 Soundsphere 2212-1 speakers' to read 'Provide 4 Soundsphere 2212-1 speakers or approved equal'.
- g) Paragraph 2.18.2; revise 'System components shall be provided as follows and manufactured by Phonic Ear' to read 'System components shall be provided as follows and manufactured by Phonic Ear or approved equal'.

Changes to Drawings:

VOLUME 1 OF 3 – PHASE, CIVIL, ENVIRONMENTAL, HAZARDOUS MATERIAL, DEMOLITION, STRUCTURAL

- 1) **S-105.1** – Foundation and Slab-On-Grade Plan – Area E
 - a) **Question:** *Sheet S-105.1, S-105.2, and S-105.3 show a dimension of 10' - 2" for the length between grid line E-6 and grid line E-7; however, this distances scales to approximately 15' - 10". What is the correct length between grid line E-6 and grid line E-7? This same issue exists on sheet A-105.1 and may exist on other drawings. Please update the drawings as appropriate.* **Answer:** Dimension between grid line E-6 and grid line E-7 should be 15'-10" on S105.1, S105.2, S105.3, and A-105.1. Update these drawings accordingly.
 - b) **Question:** *Sheet S-105.1 references detail 12/S211 in a couple locations including near the intersection of grid line E-H and E10.2 and near the intersection of grid line E-H and E-14; however, sheet S211 does not exist. Please provide sheet S211 or clarify these references.* **Answer:** Detail reference at these two locations on drawing S105.1 should be 12/S210.
- 2) **S-105.2** – Second Floor Framing Plan – Area E
 - a) Revise per answer to Question "a)" from sheet S-105.1.
- 3) **S-105.3** – Roof Framing Plan – Area E
 - a) Revise per answer to Question "a)" from sheet S-105.1.
- 4) **S-302** – Framing Schedule and Typical Details
 - a) Detail 7: Delete new MC12x31, and insert new W12x40 in lieu thereof.

VOLUME 2 OF 3 – ARCHITECTURAL

- 1) **A-103.1** – Main Level Floor Plan (Area C1)
 - a) **Question:** *C. Sheet A-103.1 depicts a slope to a floor drain for Pot Wash C169B similar to C168A; however, no slope is labeled on this sheet. Should there be a slope to the drain in Pot Wash C169B? Please clarify.* **Answer:** Insert the following note at Pot Wash C169B, "1/4" Slope to Drain."

271 Bridgeport Avenue
Bridgeport, CT 06604
Tel: 203.377.1300 Fax: 203.378.3002



ANTINOZZI ASSOCIATES
ARCHITECTURE & INTERIORS

ADDENDUM #2 (continued)

24 July 2012

Eli Whitney CTHS
Additions and Renovations Project

Page 9 of 16

- b) **Question:** *D. Sheet A-103.1 indicates that Pot Wash C176B should have 1/4"/ft slope to the drain similar to C168A; however, no slope lines are depicted on this sheet. Should there be a slope to the drain in Pot Wash C176B which does not show slope lines but labels slope to drain? Please clarify. Answer:* Insert slope-to-drain lines at Pot Wash C176B.
- 2) **A-103.2** – Main Level Floor Plan (Area C2)
- a) **Question:** *Sheet A-103.2 shows the location of the operable panel partition in the Gymnasium Room C150 and references detail 3/A-201.2 for the partition; however, this detail does not exist. What is the height of the folding partition in the Gymnasium Room C150? Please specify the height, provide an accurate reference from the plan and a detail or elevation for this item. Answer:* Within gym partition annotation text on sheets A-103.2 and A-203.2, delete reference to detail "3/A-201.2" and replace with detail "3B/A-201.1" (note sheet number). Add new detail 3B to sheet A-201.1 per SKA-10 dated 24 JULY 2012 attached. Also see specification section 102226.
- 3) **A-105.1** – Main Level Floor Plan (Area E)
- a) Revise per answer to Question "a)" from sheet S-105.1.
- 4) **A-105.2** – Wing E Upper Level and Clerestory Plan
- a) **Question:** *Please clarify exactly how the straight linear millwork at the curved exterior project north walls of room E210, E211, E212 and E213 should interface with the curved walls at the top surfaces. Should top surfaces extend to the curved walls throughout these rooms? Answer:* Insert the following note at the north wall of Rooms E210, E211, E212, and E213: "Counter top above base cabinetry shall extend to the interior face of the exterior wall. Typical for four (4) Classrooms.
- 5) **A-110.7** – Roof Details
- a) **Question:** *Detail 22/A-110.7 calls for a '5/8" Base Board' over the steel deck and under the SBS-modified bituminous membrane roofing. What is the material of this '5/8" Base Board'? Please clarify. Answer:* Delete the following phrases, "Over 5/8" Base Board" and "Over 5/8" Dens Deck" wherever they appear on sheets A-110.7, and A-110.8.
- 6) **A-110.8** – Roof Details
- a) **Question:** *Detail 22/A-110.7 calls for a '5/8" Base Board' over the steel deck and under the SBS-modified bituminous membrane roofing. What is the material of this '5/8" Base Board'? Please clarify. Answer:* Delete the following phrases, "Over 5/8" Base Board" and "Over 5/8" Dens Deck" wherever they appear on sheets A-110.7, and A-110.8.
- 7) **A-201.1** – Main Level Reflected Ceiling Plan (Area C2)
- a) Revise per answer to Question "a)" from sheet A-103.2.
- 8) **A-202.2** – Main Level Reflected Ceiling Plan (Area B2)
- a) **Question:** *A. Room B178 and B179 show type B-1 on the Room Finish Schedule and sound absorptive mat on the Reflected Ceiling Plan. Please clarify. Answer:* Delete ceiling type "B-1" in Ceiling Type Column, for line item B178 and B179.



ADDENDUM #2 (continued)

24 July 2012

Eli Whitney CTHS
Additions and Renovations Project

Page 10 of 16

- 9) **A-203.1** – Main Level Reflected Ceiling Plan (Area C1)
a) **Question:** *F. Room E209A shows type A on the Room Finish Schedule and no ceiling on the Reflected Ceiling Plan. Please clarify.* **Answer:** Insert 24" X 48" Ceiling Grid in Room E209A
- 10) **A-203.2** – Main Level Reflected Ceiling Plan (Area C2)
a) Revise per answer to Question "a)" from sheet A-103.2.
- 11) **A-205.1** – Main Level Reflected Ceiling Plan (Building E)
a) **Question:** *Main Level Reflected Ceiling Plan sheet A-205.1 shows 24" x 24" acoustical panel ceilings (type B or B-1) at room E109 Toilet, E112 Waiting Area, and E114 Storage; however, the Room Finish Schedule sheet FI-905 indicates the ceilings should be type A which are 24" x 48" acoustical ceiling panels. Please indicate the ceiling type for E109, E112, and E114 and update the drawings as applicable.* **Answer:** Delete 24" x 24" ceiling in Room E114, and insert 24" x 48" ceiling in lieu thereof. **Clarification:** E112 will remain 24" x 24" – Type B, and E109 will remain 24" x 48" – Type A
- 12) **A-303** – Exterior Elevations "B" Building
a) Revise per answer to Question "a)" from sheet A-920.
- 13) **A-540** – Building E Wall Sections
a) **Question:** *Sheet A-105.2 shows straight linear millwork at the curved exterior project north walls of room E210, E211, E212 and E213 in E-Wing at the second floor. Sheet A-105.1 does not show millwork at the curved exterior project north walls of room E127 and E132 in E-Wing at the first floor. Detail 1/A-540 and 3/A-545 depict millwork on the first floor of E-Wing at the north curved walls with a note to see floor plans for millwork; however, millwork does not appear to be shown at any of the first floor locations that apply to this detail.*

Please confirm that sheet A-105.1 is correct and that no millwork is required at the north elevations of room E127 and E132 and that the millwork depicted on the first floor of detail 1/A-540 and 3/A-545 should be ignored. **Answer:** Delete Casework shown on the lower Lever in Wall Section Detail #1.

- 14) **A-545** – Building E Wall Sections
a) **Question:** *Sheet A-105.2 shows straight linear millwork at the curved exterior project north walls of room E210, E211, E212 and E213 in E-Wing at the second floor. Sheet A-105.1 does not show millwork at the curved exterior project north walls of room E127 and E132 in E-Wing at the first floor. Detail 1/A-540 and 3/A-545 depict millwork on the first floor of E-Wing at the north curved walls with a note to see floor plans for millwork; however, millwork does not appear to be shown at any of the first floor locations that apply to this detail.*

Please confirm that sheet A-105.1 is correct and that no millwork is required at the north elevations of room E127 and E132 and that the millwork depicted on the first floor of detail 1/A-540 and 3/A-545 should be ignored. **Answer:** Delete Casework shown on the lower Lever in Wall Section Detail #3.



ADDENDUM #2 (continued)

24 July 2012

Eli Whitney CTHS
Additions and Renovations Project

Page 11 of 16

15) A-901 – Door Schedule

- a) **Question:** *Sheet A901, Door Schedule, indicates that door number A100a should have a door frame type "2-HM"; however, Remark 21 is listed which states existing frame to remain. For other door frames listed in the schedule with existing hollow metal door frames to remain the frame type is listed as "EX-HM".*

Please clarify if an existing frame should remain for door number A100a or if a new frame should be installed. Answer: Delete Frame Type/Material designation "2-HM" at line item A100a and Column Frame Type/Material; and Insert the following in lieu thereof: "EX-HM"

- b) **Question:** *Sheet A901, Door Schedule, indicates that door number A126c is not to be a double leaf door as a dot is not included in this column; however, hardware set number 25 is listed which is for a pair of openings. Also, sheet A-101.2 depicts door A126c as a single leaf door.*

Should the hardware set for door A126c be changed to a set compatible with a single door leaf? Answer: Delete Hardware type "25" located at line items A126c, and A126d, and at Column Hardware Set No.; and insert Hardware Set No "29" in lieu thereof.

- c) **Question:** *3. Room B140 shows a door opening that is not on the schedule. Please specify size and type. Answer:* Adjust door sizes and remarks per revised drawing A-901 dated 24 JULY 2012 attached.

- d) Revise sizes for doors B108b, B114b, B158c, B170a, and B170b per revised drawing A-903 dated 24 JULY 2012 attached.

- e) Clarification: Sheet layout reorganized to place schedules in alphabetical order by wing from left to right (similar to A-903). Note that doors for Room B129 were moved to the bottom of first part of B-Wing schedule.

16) A-902 – Door Schedule

- a) **Question:** *The Door Schedule sheet A-902 indicates for door C200, C201, and C202 to be type A-AL aluminum doors. Sheet A-904 indicates for door type A to be a flush door. Should these doors be changed to FRP? Answer:* Delete "A-AL" in Door Schedule column Door Type/Material, for door numbers C200, C201, and C202, and insert "A-FRP" in lieu thereof.

- b) **Question:** *The Door Schedule sheet A-902 indicates for door C125H, C125I, C125J, and C125K to be type C-AL aluminum doors. Sheet A-904 indicates for door type C to be a flush door with vision lite. Should these doors be changed to FRP? Answer:* Delete "A-AL" in Door Schedule column Door Type/Material, for door numbers C125h, C125i, C125j, and C125k, and insert "C-FRP" in lieu thereof.

- c) Clarifications: Doors C147c through C151c were moved to the bottom of the third part of C-Wing schedule. "C-WING UPPER FLOOR DOOR SCHEDULE" schedule header added for clarity above upper floor doors.



ADDENDUM #2 (continued)

24 July 2012

Eli Whitney CTHS
Additions and Renovations Project

Page 12 of 16

17) A-903 – Door Schedule

- a) **Question:** 1. Drawing A 537 Garage 100 shows a 12' high door. Schedule calls for 8'-6". Please clarify.
2. D Wing doors 100b, 100c, & 114 are noted on the schedule as 10'-x 8'-6". Architectural drawing 4/A530 notes these doors as 12' high. Please clarify. **Answer:** Adjust door sizes per revised drawing A-903 dated 24 JULY 2012 attached.
- b) Revise sizes for doors G105b, G105c, and G104a thru G-104d per revised drawing A-903 dated 24 JULY 2012 attached.

18) A-920 – Window/Curtain Wall Schedule

- a) **Question:** Window Type D 3 on Addendum #1 SKA-08 calls for a 1 Hr. fire rated project-out unit. Project out operable units will only get a 3/4 Hr. fire rating. The only way to get a 1 Hr. rating is to provide a fixed unit. Please Advise. **Answer:** Replace SKA-08 with revised SKA-08 dated 24 JULY 2012 attached. Also, replace SKA-04 with revised SKA-04 dated 24 JULY 2012 attached.

19) FI-901 – Room Finish Schedule

- a) **Question:** B. Sheet FI-102.2, Finish Floor Plan, indicates for the flooring to be VCT in Lockers B106 and Tool Crib B107; however, sheet FI-901, Room Finish Schedule, indicates for the flooring to be existing wood that is refinished. Please clarify if the floor in B106 and B107 should be VCT or existing wood that is refinished and update the documents as applicable. **Answer:** The Room Finish Schedule shall be edited as follows:
- i) Lockers B106 – Floor Material: Delete “Ex. Wood”, and insert “VCT” / Floor Color: Delete “Refinish” and insert “VCT-A-1” / Base Material: Delete “Stl Angle” and insert “Rubber” / Base Color: Delete “P-“ and insert “RB-1” / Remarks: Delete “4, 7, 9” and insert “3”
 - ii) Tool Crib B107 – Floor Material: Delete “Ex. Wood”, and insert “VCT” / Floor Color: Delete “Refinish” and insert “VCT-A-1” / Base Material: Delete “Stl Angle” and insert “Rubber” / Base Color: Delete “P-“ and insert “RB-1” / Remarks: Delete “4, 7, 9” and insert “3”
 - iii) Carpentry B108 – Floor Material: “Ex. Wood / New Wood” / Floor Color: “Refinish/Finish” / Remarks: “4, 7, 9”
- b) **Question:** C. Sheet FI-102.2, Finish Floor Plan, indicates for the flooring to be concrete in Storage B110; however, sheet FI-901, Room Finish Schedule, indicates for the flooring to be existing wood that is refinished. Please clarify if the floor in B110 should be concrete or existing wood that is refinished and update the documents as applicable. **Answer:** The Room Finish Schedule shall be edited as follows:
- i) Storage B110 – Floor Finish: Delete “Ex. Wood”, and insert “Concrete” / Floor Color: Delete “Refinish” and insert “Sealer” / Base Material: Delete “Stl Angle” and insert “Rubber” / Base Color: Delete “P-“ and insert “RB-1” / Remarks: Delete “4, 7, 9.”



ADDENDUM #2 (continued)

24 July 2012

Eli Whitney CTHS
Additions and Renovations Project

Page 13 of 16

- c) **Question:** *E. The Room Finish Schedule on sheet FI-901 through FI-905 indicates for the flooring at the stairs to be "VCT/RUB.STAIR&TREAD". Should the landings in between the first and second floors at room A100, A101, A126, A201, A227, D169, D220, E135 and E215 be VCT or RUB-1? Answer:* Insert the following new Note 15 – “Intermediate landing at Stairs to be Rubber Tile,” in the Remarks column for line items A100, A101, A126, A201, and A227.

20) FI-903 – Room Finish Schedule

- a) **Question:** *B. Room C125 shows type D on the Room Finish Schedule and 2x4 grid and tile on the Reflected Ceiling Plan. Please clarify. Answer:* Delete “C” in Ceiling Type column, for line item C125, and insert “A” in lieu thereof.
- b) **Question:** *C. Room C166, C167, D128, D135, D138, E107, and E112 show type A on the Room Finish Schedule and 2x2 grid on the Reflected Ceiling Plan. Please clarify. Answer:* Delete “A” in Ceiling Type column, for line items C166, and C167, and insert “B” in lieu thereof.
- c) **Question:** *G. Room C151B shows type A-1 and E on the Room Finish Schedule but only shows type A on the Reflected Ceiling Plan. Please clarify. Answer:* Delete ceiling type “E” in Ceiling Type Column, for line item C151B.
- d) **Question:** *D. Sheet FI-103.2, Finish Floor Plan, indicates for the flooring to be refinished wood with new game lines in Gym C150; however, sheet FI-903, Room Finish Schedule, indicates for the flooring to be "EX". Please confirm that the existing wood flooring in C150 should be refinished and game lines should be added as indicated on sheet FI-103.2. Answer:* Insert the following existing Note 9 – “Existing wood floor to be refinished,” and new Note 14 – “Add new game lines as shown on Sheet FI-103.4.” in the Remarks column for line item Gym C150.
- e) **Question:** *A. Sheet FI-903 does not list Pot Wash C168A in the Room Finish Schedule. This room is located off of Culinary Kitchen Room 168. Please confirm that Pot Wash C168A should have quarry floor tile and base. Answer:* Insert the following Room line item into the Room Finish Schedule:
- i) C168A / Pot Wash / Floor Material: Quarry Tile / Floor Color: QT-1 / Base Material: Quarry Tile / Base Color: QTB-1 / North, South, East Walls-Finish: CMU-EP1 / Ceiling Type: C.

21) FI-904 – Room Finish Schedule

- a) **Question:** *C. Room C166, C167, D128, D135, D138, E107, and E112 show type A on the Room Finish Schedule and 2x2 grid on the Reflected Ceiling Plan. Please clarify. Answer:* Delete “A” in Ceiling Type column, for line items D128, D135, and D138, and insert “B” in lieu thereof
- b) **Question:** *D. Room D220 shows type B-1 on the Room Finish Schedule and 2x4 grid and tile on the Reflected Ceiling Plan. Please clarify. Answer:* Delete “B-1” in Ceiling Type column, for line item D220, and insert “A” in lieu thereof.

271 Bridgeport Avenue
Bridgeport, CT 06604
Tel: 203.377.1300 Fax: 203.378.3002



ANTINOZZI ASSOCIATES
ARCHITECTURE & INTERIORS

ADDENDUM #2 (continued)

24 July 2012

Eli Whitney CTHS
Additions and Renovations Project

Page 14 of 16

- c) **Question:** *E. The Room Finish Schedule on sheet FI-901 through FI-905 indicates for the flooring at the stairs to be "VCT/RUB.STAIR&TREAD". Should the landings in between the first and second floors at room A100, A101, A126, A201, A227, D169, D220, E135 and E215 be VCT or RUB-1? Answer:* Insert the following new Note 15 – “Intermediate landing at Stairs to be Rubber Tile,” in the Remarks column for line items D169, and D220.
- 22) **FI-905** – Room Finish Schedule
- a) **Question:** *C. Room C166, C167, D128, D135, D138, E107, and E112 show type A on the Room Finish Schedule and 2x2 grid on the Reflected Ceiling Plan. Please clarify. Answer:* Delete “A” in Ceiling Type column, for line items E107, and E112, and insert “B” in lieu thereof
- b) **Question:** *E. Room E119 shows type A on the Room Finish Schedule and gypsum board on the Reflected Ceiling Plan. Please clarify. Answer:* Delete “A” in Ceiling Type column, for line item E119, and insert “D” in lieu thereof.
- c) **Question:** *E. The Room Finish Schedule on sheet FI-901 through FI-905 indicates for the flooring at the stairs to be "VCT/RUB.STAIR&TREAD". Should the landings in between the first and second floors at room A100, A101, A126, A201, A227, D169, D220, E135 and E215 be VCT or RUB-1? Answer:* Insert the following new Note 15 – “Intermediate landing at Stairs to be Rubber Tile,” in the Remarks column for line items E135, and E215.
- 23) **EQ-106** – Equipment Plans – Manufacturing / Cosmetology
- a) **Question:** *Sheet EQ-106, Shop Equipment - Cosmetology, item 2, is described as "Shampoo Station With Seating" and references Belvedere model HP14; however, this model is for a shampoo chair only. Should stations also be provided or just chairs? Please update the description or add a model number for the shampoo stations. Answer:* See additional equipment listed in the Cosmetology Shop Equipment Schedule on revised Sheet EQ-106 attached.

VOLUME 3 OF 3 – MECHANICAL, ELECTRICAL, PLUMBING FIRE PROTECTION, SECURITY

1) **ES-102**

- a) Add note #22 as follows:
- i) 22. “Provide concrete base for fixture type S-6 similar to Detail 3 except base dimensions shall be 18” base width x 24” deep.”

2) **E-001;**

- a) Add note #39 as follows:
- i) 39. “In each of the following Data Closets A121B, A238, B167, C124B, D205, E138, and E217 provide ¾” type AC plywood mounted from floor to ceiling covering all of the walls. Plywood to be painted with flame retardant gray paint. Coordinate installation with all trades.”



ADDENDUM #2 (continued)

24 July 2012

Eli Whitney CTHS
Additions and Renovations Project

Page 15 of 16

3) E-202.2;

a) Detail #3; Add the following:

- i) Provide ceiling mounted occupancy sensor in addition to the switching for control of lights in this area.

4) E-701;

a) Detail #8; Make corrections to the following room numbers:

- i) Service ground boxes to be located in rooms B148A and C133.
- ii) TMGB to be located in room A121B.
- iii) Fire Alarm Panel is in room C102B.
- iv) PA system is in room C118A.

5) M-102.2 (Issued);

- a) Added spark detection and spray nozzle to dust collection system. Duct rerouting was necessary for this addition.
- b) Added abort damper at dust collection system discharge.

6) M-401 (Issued);

- a) Changed the plate frame the exchanger schedule so the Propylene Glycol was on the hot side in lieu of the cold side.

7) P-101.3 (Issued);

- a) Removed temporary Science Room work.

8) P101.4 (Issued);

- a) Removed temporary Surgical Tech Suite.

9) P104.2 (Issued);

- a) Revised waste oil collection tank.



ADDENDUM #2 (continued)

24 July 2012

Eli Whitney CTHS
Additions and Renovations Project

Page 16 of 16

Attachments:

- 1) 22 00 00 – Plumbing
- 2) 23 70 00 – Air Handling & Treatment
- 3) Drawing SKA-04 – Revised Partial B-Wing – West Elevation (Partial)
- 4) Drawing SKA-08 – Revised Window Types (Partial)
- 5) Drawing SKA-10 – Detail at Gym Folding Partition
- 6) A-901 – Door Schedule
- 7) A-902 – Door Schedule
- 8) A-903 – Door Schedule
- 9) EQ-106 – Equipment Plans – Manufacturing / Cosmetology
- 10) M-102.2 – Area B2 Main Level Mechanical
- 11) M-401 – Mechanical Schedule Sheet #1.
- 12) P-101.3 – Area A1 Upper Level Plumbing
- 13) P-101.4 – Area A2 Upper Level Plumbing
- 14) P-104.2 – Area D2 Main Level Plumbing

END OF ADDENDUM #2

271 Bridgeport Avenue
Bridgeport, CT 06604
Tel: 203.377.1300 Fax: 203.378.3002



ANTINOZZI ASSOCIATES
ARCHITECTURE & INTERIORS

SECTION 22 00 00 - PLUMBING

PART 1 – GENERAL

1.01 GENERAL REQUIREMENTS

1. Work of this section shall be governed by the Contract Documents. Provide materials, labor, equipment and services necessary to furnish, deliver and install all work of this Section as shown on the drawings, as specified herein, and/or as required by job conditions.
2. Mechanical, Electrical, Plumbing, and Fire Protection removals shall be performed during each phase of the project. Occupied areas shall be operational for the use by the owner at all times during the project. At no time shall the area be without the required Mechanical, Electrical, Plumbing, and Fire Protection services. The contractor shall provide all temporary connections to maintain these services.
3. Refer to specification Division 019100. The Commissioning services for Division 220000 systems are specified within Division 019100 Commissioning. The General Contractor, the GC's Subcontractors and the Division 26 Contractor shall include all manpower, time, parts, labor, and resources required to accomplish the commissioning as specified.
4. The contractor shall refer to specification 01110 for timing and phasing coordination. It is the intent of the documents that the contractor coordinate systems, so that, they remain active during the construction and renovation of the phased project.
5. Refer to Section 230000, 1.13 for all warranty requirements.
6. Refer to Section 230000 **2.01** for Video recording of material, equipment, operation and training.
7. Due to the phasing of this project the contractor shall provide all tie-ins, live or otherwise required to provide functional systems for this project.
8. Refer to Section 230000, 3.2 for all maintenance requirements. This contractor provides a complete maintenance log for each piece of equipment.

1.02 REFERENCES

1. Perform the work in accordance with the requirements of the Contract General Conditions, Section 230000 General Provisions, Section 230500 Removals, applicable division 23 sections and with the provisions of all applicable Local, State, and Federal Codes and laws including the 2003 IPC (International Plumbing Code).

1.03 SCOPE OF WORK

1. The work under this Section shall include all incidentals, labor, material, equipment, appliances, services, hoisting, scaffolding, supports, tools, consumable items, fees, licenses, and administrative tasks required to complete and make operable the plumbing work shown on the drawings and specified herein, including the International Plumbing Code.

2. The Contractor shall furnish and install all equipment as necessary to provide a complete installation including system check out and start up on each item and system. The following equipment shall be provided:
 - a. Sanitary, waste, and vent systems.
 - b. Building sanitary drain to 5'-0" outside building.
 - c. Storm and roof drainage systems.
 - d. Building storm drain to 5'-0" outside building.
 - e. Domestic hot and cold water system.
 - f. Fire protection water service from point of connection within the building.
 - g. Gas systems.
 - h. Kitchen equipment plumbing support systems and connections.
 - i. Pipe materials
 - j. Pipe hangers and supports
 - k. Insulation
 - l. Valves
 - m. Cross connection protection devices.
 - n. Pipe sleeves and seals.
 - o. Drains
 - p. Cleanouts
 - q. Plumbing fixtures
 - r. Water heating equipment
 - s. Pumps
 - t. Grease interceptors
 - u. Hose bibbs.
 - v. Access panels.
 - w. Misc. plumbing specialties.

1.04 WORK BY OTHER DIVISIONS

1. Division 26 shall provide power wiring to electrical devices. Section 220000 shall provide and install all control wiring required for equipment operation. Section 220000 shall provide motor starters for installation by Division 16.

2. Plumbing devices, faucets, valves and fittings required for food service equipment including gas solenoid shut-off valves for kitchen equipment shall be provided by other divisions. Section 220000 shall provide and install piping connections. Coordinate requirements. Food service equipment shall be assembled by other divisions.

3. Piping and related excavation and backfilling for services (except the fire protection service) from the utility connections to a connection point 5'-0" outside of the building line.
4. Piping and related excavation and backfilling for fire protection service from the water supply source to a connection point 5'-0" outside of the building line.

1.05 MATERIALS, EQUIPMENT AND SYSTEM

1. Factory wiring of components shall conform to all State, Local, and Federal Codes and Laws.
2. The criteria of design and performance to produce the required operation are based on equipment of the named manufacturers. Equipment of other manufacturers shall be considered, subject to its acceptability in the Engineer's judgement and opinion. The equipment must conform to the operational characteristics and dimensions established by specified item and the drawings for mechanical spaces and other clearances.
3. The following manufacturers, vendors or materials, when provided in accordance with requirements of this Division, are approved for use. Materials supplied shall comply with specification requirements and be of a product of approved manufacturers. No deviations from this list shall be permitted unless specifically approved, in writing, after submission of satisfactory evidence relative to compliance with specification requirements.

1.06 ADDITIONAL WORK UNDER THIS SECTION

1. All existing sanitary and storm piping indicated on the plumbing drawings to be re-used shall be routed clean and inspected via camera probing system inside piping to determine condition and location prior to being re-used. Existing domestic water piping to remain to be visually inspected and if any problems report to engineer/architect.
2. Sawcutting, excavating, backfilling, compacting, rough patching, and prime painting shall be provided under this section. Coordinate requirements.

PART 2 - PRODUCTS

2.01 PIPE MATERIALS

1. Sanitary, waste, kitchen waste, vent, and storm piping above ground (up to and including 10" size) within building: Hubless cast iron pipe with no hub fittings CISPI301 and 4 & 6 band "Huskey Series 4000" clamps.

Manufacturers: Charlotte Pipe
 Tyler Pipe
 ABI Foundry

2. Sanitary, waste, kitchen waste, vent, and storm piping below ground (all sizes) within building: service weight cast iron pipe and fittings with hub and spigot ends, ASTM A74. Seal: one-piece neoprene rubber gaskets matching the internal configuration of the hub.

Manufacturers: Charlotte Pipe
 Tyler Pipe
 ABI Foundry
3. Indirect waste piping above ground: hard drawn seamless Type L, copper tubing ASTM B88 with wrought copper solder fittings ANSI B16.22 and "Bridgit" or other no lead content solder joints ASTM B32-83, alloy Grades SN96 or SB5. Solder flux lead content – zero percent.
4. Domestic hot and cold water piping underground (up to 2" size): Type K soft copper tubing ASTM B88 with Flared fittings for copper ASA A40.2, with ½" Armaflex SSA 2000 insulation. No joints are permitted below concrete slabs.
5. Fire protection water service piping above ground: Refer to Section 210000 for specification requirements.
6. Gas piping up to and including 2" size: shall be TracPipe Corrugated Stainless Steel Tubing (CSST) by Omegaflex, Inc. or pre-approved equal. Pressure carrier shall be series 300 stainless steel per ASTM A240; no annealing or heat-treating permitted after corrugating operation. Fittings shall be AutoFlare mechanical attachment fittings, material: yellow brass with series 300 stainless steel insert. Fittings shall terminate in cleanly cut taper pipe threads conforming to the Standard for Pipe Threads, General Purpose, ANSI/ASME B1.20.1. A flared metal-to-metal seat shall be used to accomplish gas sealing. No elastomer sealing rings or fiber gaskets permitted. Non-metallic jacket shall be colored yellow to visibly indicate conveyance of fuel gas. Jacket material shall be non-halogenated, fire-retardant polyethylene. Polyvinyl chloride (PVC) is not permitted. ASTM E84 Ratings shall be less than 14 for flame spread and smoke. Pipe installation requirements shall be per TracPipe Design and Installation Guide.
7. Gas piping (over 2" size): schedule 40 black steel ASTM A106, with schedule 40 but weld fittings.
8. Acid waste and vent piping shall be manufactured from Corzan® CPVC Type IV Grade I compounds, ASTM Cell Classification 23447 for fittings and 24448 for pipe. All pipe shall be schedule 40 dimensions per ASTM F441. All fittings shall be drainage pattern per ASTM D3311. One-Step solvent cement shall be specially formulated for chemical waste applications and conform to ASTM F493. All pipe, fittings and cement shall be supplied as a system by a single manufacturer and shall be certified by NSF International for use in corrosive waste drainage systems as a Special Engineered (SE) product and shall bear the NSF mark. Acid waste and vent piping shall be the ChemDrain™ system as manufactured by Charlotte Pipe and Foundry Co. Installation to be in accordance with manufacturer's instructions and all applicable local code requirements.

9. Fire water service, domestic water service piping below ground (3" size and larger): Class 52 (exterior coated), cement lined ductile iron mechanical joint pipe, ANSI A21.51/AWWA C151 with 350 psi cement lined ductile iron mechanical joint fittings ANSI A21.10/AWWA C110 and ANSI A21.11/AWWA C111. Double cement lining on interior shall be in accordance with ANSI A21.4/AWWA C104. Provide and install tie-rods and clamps at each fitting. Coat rods and clamps, with an environmentally safe exterior corrosion protection coating. Provide thrust blocks at changes of direction.
10. Fire service piping (Interior) – Standard weight black steel (Schedule 40), seamless or welded mild steel ASTM A-135 or A-53 with welded fittings.
11. Compressed air piping above slab: Schedule 40 Black steel ASTM A106, threaded end ANSI B1.20.1 with class 150 malleable iron threaded fittings ANSI B16.3.
12. Radon piping: Schedule 40 PVC, Type DWV, ASTM D 2665, with chemically fused joints.
13. Underground gas service piping: plastic piping conforming with "standard specifications for thermoplastic gas pressure pipe, tubing, and fittings" ASTM D2513. Pipe shall be marked "GAS" and "ASTM D2513". Piping shall be installed in accordance with NFPA 54, and manufacturer's requirements.
14. Domestic hot water, cold water and hot water recirculating piping above ground.

a. SUMMARY

- 1) Copper Tubing and Fitting System for Hot and Cold Water Distribution

b. DEFINITIONS

- 1) ASME: American Society of Mechanical Engineers
- 2) ASTM: American Society for Testing and Materials
- 3) EPDM: Ethylene-propylene-diene-monomer
- 4) IAPMO: International Association of Plumbing & Mechanical Officials
- 5) ICC: International Code Council
- 6) MSS: Manufacturers Standardization Society
- 7) AWWA: American Water Works Association
- 8) NSF: National Sanitation Foundation
- 9) UL: Underwriters Laboratory
- 10) NFPA: National Fire Protection Association
- 11) FM: Factory Mutual

c. REFERENCES

- 1) ASME A13.1: Scheme for the Identification of Piping Systems
- 2) ASME B1.20.1: Pipe Threads, General Purpose (inch)
- 3) ASME B16.18: Cast Copper Alloy Solder Joint Pressure Fittings
- 4) ASME B16.22: Wrought Copper and Copper Alloy Solder-Joint Pressure Fittings
- 5) ASME B16.26: Cast Copper Alloy Fittings for Flared Copper Tube
- 6) ASME B31.9: Building Services Piping

- 7) ASTM B75: Standard Specification for Seamless Copper Tube
- 8) ASTM B88: Standard Specification for Seamless Copper Water Tube
- 9) ASTM B813: Standard Specification for Liquid and Paste Fluxes for Soldering Applications of Copper and Copper Alloy Tube
- 10) ASTM B828: Standard Practice for Making Capillary Joints by Soldering of Copper and Copper Alloy Tube and Fittings
- 11) AWWA C651: Standard for Disinfecting Water Mains
- 12) ICC: International Plumbing Code
- 13) ICC: International Mechanical Code
- 14) MSS-SP-58 Pipe Hangers and Supports Materials, Design and Manufacturer
- 15) MSS-SP-69 Pipe Hangers and Supports Selection and Application
- 16) NSF 61 Drinking Water System Components –Health Effects
- 17) NFPA 54 National Fuel Gas Code

d. **QUALITY ASSURANCE**

- 1) Installer shall be a qualified installer, licensed within the jurisdiction,
- 2) and familiar with the installation of ProPress copper press joint systems.
- 3) ProPress copper press fittings shall be installed using the proper tool,
- 4) actuator, jaws and rings as instructed by the press fitting manufacturer.
- 5) The installation of copper tubing for hot and cold water distribution systems shall conform to the requirements of the ICC International Plumbing Code or IAPMO Uniform Plumbing Code.
- 6) The installation of copper tubing in sprinkler or standpipe systems shall conform to NFPA 13, 13D, 13R and 14.
- 7) The installation of copper tubing in Hydronic systems shall conform to the requirements of the ICC International Mechanical Code or the IAPMO Uniform Mechanical Code.
- 8) ASME Compliance: ASME B31.9 for building services piping valves.

e. **DELIVERY, STORAGE AND HANDLING**

- 1) Copper tubing shall be shipped to the job site on truck or in such a manner to protect the tubing. The tubing and fittings shall not be roughly handled during shipment. Tubing and fittings shall be unloaded with reasonable care.
- 2) Protect the stored product from moisture and dirt. Elevate above grade. When stored inside, do not exceed the structural capacity of the floor.
- 3) Protect fittings and piping specialties from moisture and dirt.

f. **PROJECT CONDITIONS**

- 1) Verify length of tubing required by field measurements.

g. **WARRANTY**

- 1) The tubing and fittings manufacturer shall warrant that the tubing and fittings are free from defects and conform to the designated standard. The warranty shall only be applicable to tubing and fittings installed in accordance with the manufacturer's installation instructions.

- 2) The manufacturer of the fittings shall not be responsible for the improper use, handling or installation of the product.
- h. MANUFACTURES
- 1) Press Fittings: Viega, 301 N. Main, Floor 9, Wichita, KS
Telephone: (316) 425-7400, Website: www.viega-na.com.
- i. MATERIAL
- 1) Tubing Standard: Copper tubing shall conform to ASTM B 75 or ASTM B88.
 - 2) Fitting Standard: Copper fittings shall conform to ASME B16.18, ASME B16.22 or ASME B16.26.
 - 3) Press Fitting: Copper and copper alloy press fittings shall conform to material requirements of ASME B16.18 or ASME B16.22 and performance criteria of IAPMO PS 117. Sealing elements for press fittings shall be EPDM. Sealing elements shall be factory installed or an alternative supplied by fitting manufacturer. Press ends shall have SC (Smart Connect™) feature design (leakage path). In ProPress ½”to 4” dimensions the Smart Connect Feature assures leakage of liquids and/or gases from inside the system past the sealing element of an unpressed connection. The function of this feature is to provide the installer quick and easy identification of connections which have not been pressed prior to putting the system into operation.
 - 4) Threaded Fittings: Pipe Threads shall conform to ASME B1.20.1.
 - 5) Hanger Standard: Hangers and supports shall conform to MSS-SP-58.
- j. SOURCE QUALITY CONTROL (for FM approved projects see notation D)
- 1) All fittings in contact with drinking water shall be listed by a third party agency to NSF 61.
 - 2) All fittings used in Fuel Gas Applications shall be listed by a third party agency as being acceptable for fuel gas piping systems.
 - 3) All fittings used in Fire Sprinkler Applications shall be UL listed.
 - 4) All fittings used in Fire Sprinkler Applications shall be FM approved.
- k. EXAMINATION
- 1) The installing contractor shall examine the copper tubing and fittings for defects, sand holes or cracks. There shall be no defects of the tubing or fittings. Any damaged tubing or fittings shall be rejected.
 - 2) The installing contractor shall insure that sealing elements are properly in place and free from damage. For Sizes 2-1/2”to 4”, installer should insure that the stainless steel grip ring is in place.
- l. PREPARATION
- 1) Copper tubing shall be cut with a wheeled tubing cutter or approved copper tubing cutting tool. The tubing shall be cut square to permit proper joining with the fittings.

- 2) Remove scale, slag, dirt and debris from inside and outside of tubing and fittings before assembly. The tubing end shall be wiped clean and dry. The burrs on the tubing shall be reamed with a deburring or reaming tool.

m. **INSTALLATION GENERAL LOCATIONS**

- 1) Plans indicate general location and arrangement of piping systems. Identified locations and arrangements are used to size tubing and calculate friction loss, expansion, pump sizing and other design considerations. Install piping as indicated, except where deviations to layout are approved on coordination drawings.

n. **INSTALLATION**

- 1) Pressure Rating: Install components having a pressure rating equal to or greater than the system operating pressure.
- 2) Install piping free of sags, bends and kinks.
- 3) Change in Direction: Install fittings for changes in direction and branch connections. Where approved, changes in direction may also be made by bending of Types K and L tube.
- 4) Solder Joints: Solder joints shall be made in accordance with ASTM B 828. The temperature of the joint during soldering shall not be raised above the maximum temperature limitation of the flux.
- 5) Threaded Joints: Threaded joints shall have pipe joint compound or Teflon tape applied to the male threads only. Tighten joint with a wrench and backup wrench as required.
- 6) Flared Joints: Flared copper tube joints shall be made by the appropriate use of cast copper alloy fittings. Flared ends of copper tube shall be of the 45-degree flare type and shall only be made with a flaring tool designed specifically for that purpose.
- 7) Press connections: Copper and copper alloy press connections shall be made in accordance with the manufacturer's installation instructions. The tubing shall be fully inserted into the fitting and the tubing marked at the shoulder of the fitting. The fitting alignment shall be checked against the mark on the tubing to assure the tubing is fully engaged (inserted) in the fitting. The joints shall be pressed using the tool(s) approved by the manufacturer.
- 8) Pipe Protection: Provide protection against abrasion where copper tubing is in contact with other building members by wrapping with an approved tape, pipe insulation or otherwise suitable method of isolation.
- 9) Penetration Protection: Provide allowance for thermal expansion and contraction of copper tubing passing through a wall, floor, ceiling or partition by wrapping with an approved tape or pipe insulation or by installing through an appropriately sized sleeve. Penetrations for fire resistant rated assemblies shall maintain the rating of the assembly.
- 10) Backfill Material: Backfill material shall not include any ashes, cinders, refuse, stones, boulders or other materials which can damage or break the tubing or promote corrosive action in any trench or excavation in which tubing is installed.

- 11) Horizontal Support: Install hangers for horizontal piping in accordance with MSS-SP-69 or the following maximum spacing and minimum rod sizes.
- 12) Vertical Support: Vertical copper tubing shall be supported at each floor.
- 13) Galvanic Corrosion: Hangers and supports shall be either copper or vinyl coated to prevent galvanic corrosion between the tubing and the supporting member.
- 14) Seismic Restraint: In seismic areas, copper tubing shall be installed to withstand all seismic forces.
- 15) Piping Identification: Copper tubing systems shall be identified in accordance with the requirements of ASME A13.1.

o. FIELD QUALITY CONTROL

- 1) Water Testing: The copper tubing system shall be water tested for joint tightness. The piping system shall be filled with water. The system shall be pressurized to the maximum pressure and length of time required by the code or standard. The system shall have no leaks at the rated pressure.
- 2) Air Testing: The copper tubing system shall be air tested for joint tightness. The piping system shall be pressurized with air to the maximum pressure of the system or to the code or standard required minimum for the required length of time. The system shall have no leaks at the rated pressure.

p. CLEANING (potable water systems)

- 1) Disinfection: The copper hot and cold water distribution system shall be disinfected prior to being placed in service. The system shall be disinfected in accordance with AWWA C651 or the following requirements:
 - a) The piping system shall be flushed with potable water until discolored water does not appear at any of the outlets.
 - b) The system shall be filled with a water chlorine solution containing at least 50 parts per million of chlorine. The system shall be valved off and allowed to stand for 24 hours or the system shall be filled with a water chlorine solution containing at least 200 parts per million of chlorine. The system shall be valved off and allowed to stand for 3 hours.
 - c) Following the standing time, the system shall be flushed with water until the chlorine is purged from the system.

15. ***Domestic cold water above ground (over 4" size): hard drawn seamless Type L copper tubing ASTM B88 with wrought copper solder fittings ANSI B16.22 and "Bridgit" or other no lead content solder joints ASTM B32-83, alloy Grades SN96 or SB5. Solder flux lead content-zero percent.***

2.02 PIPE HANGERS, SUPPORTS, SEISMIC RESTRAINT, AND VIBRATION ISOLATION

1. Pipe hangers and supports: Refer to Section 230523.
2. Seismic restraint: Refer to Section 230000 and Section 230548.

3. Vibration isolation: Refer to Section 230700.

2.03 INSULATION

1. Insulation: Refer to Section 230700. Existing piping to be re-used to be re-insulated after asbestos abatement.

2.04 VALVES

1. General: Refer to section 230523 for general plumbing service valves.
 - a. Domestic water systems up to 2-1/2" size: Nibco T-595-Y, 3 piece, full port, bronze threaded, 600 psi WOG.
 - b. Domestic water systems size 3" and over: Class 125, IBBM, gate valve.
 - c. Check valves for domestic water systems up to 2-1/2" size: class 125 all bronze, silent type, threaded.
 - d. Check valves for domestic water systems sizes 3" and over: class 125 IBBM flanged, silent check valve.
 - e. Balancing valve (domestic hot water circulation): All bronze, threaded end, calibrated stem, balancing ports, Armstrong CBVT series.
 - f. Fire Protection Water Service Valve - UL listed and FM approved, 6" grooved-end butterfly valve equipped with built-in tamper switch. Victaulic series 708-W.
2. Reduced pressure backflow preventers (rpz) - sizes 3/4" through 2": UL listed, AWWA, USC, and SBCCI/IAPMO approved bronze body reduced pressure zone air gap equipped with stainless steel relief and check valves, oversized copper funnel for pressure relief discharge piped to drain, bronze test cocks, integral body unions, bronze strainer and inlet and outlet ball valves. Manufacturer: Watts 909 series.
3. Fire Protection backflow preventer: UL/FM approved Watts 909DCDA doublecheck detector assembly 6" size.
4. Hose end drain valve NIBCO Fig. No. T-113-HC, all bronze gate (Watts #B-6000-cc, all bronze ball valve) with 3/4" hose thread outlet, threaded cap, rubber gasket and safety chain.
5. Gas service valves (exterior): UL listed, for gas service, lubricated, semi-steel plug type, 100% pipe area, with threaded end ANSI B16.10 for up to 2" size, and 125 lb. ANSI B16.1 flanged for sizes over 2", 200 psi WOG, Manufacturer Homestead 6111/612 series.

6. Domestic water reduced pressure zone backflow preventers (RPZ) – sizes 2-1/2” to 4”:
UL listed, AWWA, USC and SBCCI/IAPMO approved iron body reduced pressure zone
air gap equipped with bronze relief and check valves, oversized copper funnel for
pressure relief discharge piped to drain, bronze test cocks, complete with F.D.A.
approved epoxy coated strainer and resilient wedge inlet and outlet gate valves.

Manufacturer: Watts 909 series
Febco 825Y series.
Zurn/Wilkins 975 series.

7. Gas pressure regulating valves: Pilot controlled, and actuated. Located at gas meter on
site.

Manufacturer: Maxitrol RV series
Rockwell 243-RPC series.

Gas Outlet Valve (GOV): Deck mounted single laboratory ball valve.

Manufacturer: Water Saver Faucet Co.
Model #L4200-131WS

8. Air Admittance Valve
(AAV/Chem Vent): Vent termination for individual vent.

Manufacturer: Studor, Inc., Mini-Vent.
Item #20301 Chem-vent in labs

9. Emergency gas shut-off valve assembly (EGV)

- a. Solenoid valve: UL listed, FM approved for gas service, explosion proof, two-way normally closed. Solenoid valve shall be compatible with specified Relay Panel, ASCO #8215, or as required.
- b. Master control station: Provide one key-operated (reset), normally open switch and normally closed push button mounted on a common stainless steel face plate for flush installation. “Gas Valve Control” inscribed on the faceplate and switches labeled. Include 4-inch square wall box. Master control station: ASCO #216B89.
- c. Auxiliary control stations: Provide auxiliary control stations, in addition to the master control station, where indicated on the drawings. ASCO#173A19.
- d. Relay panel: UL listed relay panel circuit with control transformer, relay switch, and block terminal. Relay assembly housed in a NEMA 1, 16 gauge flush wall cabinet with secured cover. Relay panel: ASCO 108D10C for valves up to 2”; ASCO 108D90C for valves over 2”.

10. Water pressure regulating valve (PRV): the valve type shall be a fluid actuated pilot controlled pressure regulating valve equipped with a pressure sustaining feature that will cut out flow at a pre-set minimum pressure. The cut-off minimum pressure shall be set in the field after a documented flow test and water supply curve is performed and plotted. The valve shall incorporate:
 - a. Bronze Body
 - b. Sealed FDA approved elastomer diaphragm
 - c. Stainless steel spring and stem
 - d. Quad-ring flow throttling retainer
 - e. Brass hydraulic control pilots
 - f. Copper control tubing
 - g. Full size FDA approved strainer and blow down valve.
 - h. Inlet and outlet pressure gauges with bleed shut off valves on the gauge stem.

Manufacturer: Watts 115-2 series
Watts Regulator Co. ACV Div., Houston, TX
Cla-Val 92-01 series

2.05 PIPE SLEEVES AND SEALS

1. Masonry walls and slabs: Schedule 40 galvanized steel pipe with integral water stop.
2. Piping seal: (interior walls contact with earth): interlocking expandable synthetic rubber links, assembled with corrosion resistant bolts, nuts and pressure plates; "Link type seal."
3. Piping seal: (interior floor slabs in contact with earth): seal between pipe and sleeve with a flexible elastomeric caulk listed specifically as a pipe sealant.
4. Sleeve adapters: coated cast iron, equipped with flashing clamp.
5. Fire and smoke seal: UL listed, approved and tested fire and/or smoke sealing material installed in all fire and/or smoke rated floor and partitions in accordance with manufacturer's recommendations. Refer to Section 230000.

2.06 DRAINS

1. General:
 - a. Provide all poured in place drains with 24" x 24" vinyl flashing.
 - b. All sanitary drains to be provided with trap guard insert as manufactured by Proset in lieu of trap primers.
2. Floor drain toilet rooms and kitchens (FD): cast iron body, bottom outlet, 7" diameter nickel bronze top, trap primer connection, seepage pan and combination membrane flashing clamp.

Manufacturer: Zurn ZN-415- type B strainer.
Smith 2010.
Wade 1100STD

3. Floor drain mechanical rooms (FD): heavy duty floor drain with, cast iron body, bottom outlet, 9" diameter cast iron top, trap primer connection, seepage pan and combination membrane flashing clamp, and funnel.

Manufacturer: Zurn Z-508.
Smith 2120.
Wade 1310.

4. Roof drain (RD): heavy duty drain with, 15" diameter cast iron body, bottom outlet, 12" diameter cast iron dome, roof sump receiver, under-deck clamp, extension collar (as required), and combination membrane flashing clamp/gravel guard.

Manufacturer: Zurn Z-100 series.
Smith 1010 series.
Wade 3000 series.

5. Floor Sink (FS): 8" square x 6" deep cast iron flanged receptor with acid resistant coated (ARC) interior, sediment bucket, ½ grate, seepage holes and flashing clamp.

Manufacturer: J.R. Smith 3411Y
Wade 9110
Zurn Z1910

6. Trench Drain (TD-ADA): Multiple section trench drain with bottom outlet, flange, extra heavy duty top with security screws. Grating shall be ADA compliant with spaces no greater than ½" wide. If grating has elongated openings, then they shall be placed so that the long dimension is perpendicular to the dominant direction of travel.

Manufacturer: Wade 2950 series
Mifab T1330-FL-4
Zurn Z866 series

7. Areaway drain (AD): Heavy duty drain with, cast iron body, bottom outlet, 12" x 12", bronze finish, seepage pan and combination membrane flashing clamp.

Manufacturer: Josam 37810 series
J. R. Smith
Zurn

8. Overflow Roof Drain (ORD): Heavy duty drain with 15" diameter cast iron body, polyethylene dome, underdeck clamp, combination membrane flashing clamp/gravel guard with 2" high integral PVC standpipe.

Manufacturer: J. R. Smith 1070 series
Josam
Zurn

9. Storm overflow nozzle: Stainless steel downspout cover with hinged strainer
Manufacturer: Zurn ZS-199-DC – sizes indicated on plan.
J. R. Smith
Josam
10. Shower Drain: Round top, cast iron body, adjustable strainer head.
Manufacturer: J. R. Smith Fig. 2005Y
Josam
Zurn
11. Downspout Boot (DB): Cast iron transition piece connecting exterior downspouts to cast iron piping in ceiling. 4” round, provide flashing.
Manufacturer: J.R. Smith 1787
Josam
Zurn
12. Roof Drain (RD2): Heavy duty drain with 15” diameter cast iron body, side outlet, 12” diameter cast iron dome roof sump receiver, under deck clamp, extension collar (as required) and combination membrane flashing clamp/gravel guard.
Manufacturer: J.R. Smith 1020Y
Zurn Z100 Series
Wade 3000 Series

2.07 CLEANOUTS

1. General: Provide all poured in place cleanouts with 24" x 24" vinyl flashing.
2. Floor cleanout (DPCO): areas incorporating floor finishes, adjustable round scoriated heavy duty nickel bronze secured top, cast iron body, flashing flange and clamp, tapered bronze plug.
Manufacturer: Zurn ZN-1400 series.
Smith 4020 series.
Wade 6000Z series.
3. Floor cleanout (DPCO): exposed concrete floor areas, adjustable round scoriated heavy duty cast iron secured top, cast iron body, flashing flange and clamp, tapered bronze plug.
Manufacturer: Zurn Z-1400 series.
Smith 4020 series.
Wade 6000Z series.
4. Floor cleanout (DPCO): carpeted areas, adjustable round scoriated heavy duty nickel bronze secured top, carpet marker, cast iron body, flashing flange and clamp, tapered bronze plug.

Manufacturer: Zurn ZN-1400 series.
Smith 4020 series.
Wade 6000 series.

5. Wall plate cleanout cover (WPCO): provided at cast iron cleanouts with tapered bronze plug a 6" x 6" chrome/nickel plated bronze square frame and plate secured with vandal proof screws.

Manufacturer: Zurn ZANB-1460 series.
Smith 4730 series.
Wade 8480ST series.

2.08 PLUMBING FIXTURES – note that fixture types indicated are subject to change as they are selected by Architect. Fixture types are indicated here only to establish a general level of quality.

1. Fixtures: new, complete with trimmings and fittings, including faucets, carriers, supplies, stops, traps, tailpieces, waste plugs, casings, hangers, plates, brackets, anchors, supports, hardware and fastening devices.
2. Stainless steel: Type 302, 304, 316, or 317, as noted, sound deadened.
3. Trimmings and fittings: construct of forged, cast, rolled or extruded brass or bronze with monel and other suitable non-corrosive parts: designed with easily renewable parts that are subject to wear or deterioration. No die castings and stampings other than brass or stainless steel. Plumbing trim shall consist of:

Exposed surfaces: chrome plated.
Pipe: copper type L.
Pipe fittings: threaded bronze.
Supply stops: chrome plated bronze, stuffing box, renewable seat washer.
Waste tailpiece: minimum #17 gauge brass.
Escutcheons: one-piece chrome plated cast brass or stainless steel.

4. Water closets (WC and HC WC): flush valve, standard and handicapped (ADA compliant), vitreous china, wall hung, 1.5 gpf low flow, elongated, siphon jet, with 1-1/2" top spud. Seat: heavy-duty solid plastic elongated open front complete with flush valve (include trap primer on 1 flush valve in each toilet room equipped with floor drain) combined and concealed carrier and support with heavy duty EPDM gasketing. Color: white. Provide (2) extra water closets to the owner and all listed components of 2.8 D for educational purposes. They will be used for the student plumbing shop.

Fixture: American Standard "Afwall" 2257.103.
Kohler "Kingston lite" K-4330.
Eljer "Auburn" 111-1505.

Seat: Church #9500C.
Olsonite #95.

Flush valve: Optima 111 ES-S or pre-approved equal.
Zurn Z-6000-WS-1 series.
Delany 402-1 series.

5. Urinal (UR, HC UR): standard and handicapped (ADA compliant), vitreous china, wall hung, 1.0 gpf low flow, washout, with 3/4" top spud complete with Flush Valve. Concealed carrier support. Color: white. Provide (2) extra urinals to the owner and all listed components of 2.8 E for educational purposes. They will be used for the student plumbing shop.

Fixture: American Standard "Washbrook" 6501.010.
Kohler "Bardon Lite" K-4960-T.
Eljer "Correcto" 161-1030.

Flush valve: Sloan Royal Optima 186 ES-S or pre-approved equal.
Zurn
Delany

6. Wall hung lavatories (LAV), (HC LAV): vitreous china, standard and handicapped (ADA compliant), 20-1/2" x 18-1/4" x 6-1/2" deep, concealed arm carrier, drilled for 4" O.C. faucet, 1-1/2" chrome plated cast brass P trap with cleanout plug, chrome plated brass angle stops with loose key operator, grid drain and tailpiece. Insulate trap and hot water and cold piping below handicap lav with insulation kit. Color: white. HC rim height 34", knee clearance 27"H, 30"W, 19"Deep. Provide (2) extra wall hung lavatories to the owner and all listed components of 2.8 F for educational purposes. They will be used for the student plumbing shop.

Fixture: American Standard "Lucerne" 0356.041.
Kohler
Eljer

Faucet: Sloan ETF-80-P-BDT with mixing valve and transformer.
(electric sensor)
Symmons
Delta

Insulation: TRUEBRO Model 101
McGuire Pro Wrap
HW & Drain pipes under HC Lav.

7. Single compartment sink (S1) (HC S1)(HC AS2): standard, single compartment 25" x 21" x 6" deep, left or right offset drain, 18 gauge, type 302 stainless steel, self-rimming sink with (3) hole rear deck, 2-piece strainer assembly and tailpiece, 1-1/2" chrome plated cast brass P-trap with cleanout plug, chrome plated brass angle stops with loose key operator. Chrome plated brass single lever faucet. Provide chrome plated brass cover for third sink hole on rear ledge. 6" bowl depth. HC rim height 34", knee clearance 27"H, 30"W, 19"Deep. ADA compliant.

- Fixture: Elkay LRAD-2521. L or R
Just
Dayton
- Drain: Elkay LK-35
- Faucet: Delta 710 WFHDF
Symmons
Moen
- Insulation: TRUEBRO Model 101
McGuire Pro Wrap
HW & Drain pipes under HC S1 & AS2
8. Mop receptors (MR): 24" x 24" x 12" deep, terrazzo basin drain fitting and strainer, edge guard. Faucet: Wall mounted with bucket hook, vacuum breaker and wall bracket and hose thread end. Hose and bracket and mop hanger.
- Fixture: Fiat TST-100 series
Stern Williams SB-900 series
Florestone Model 80 series
- Faucet: Chicago 897 series
T&S B-66655-BSTR series
- Accessories: Hose Fiat 832-AA, mop hanger Fiat 899-CC, bumper guard
Fiat 1239-BB, and strainer Fiat 1453-BB
9. Salon Sink (S2): Porcelain enamel cast iron shampoo bowl complete with vacuum breakers, fixture, sprayer and strainer. 1-1/2" chrome plated cast P-trap with cleanout plug. Chrome plated brass angle stops with loose key operator. Color by architect.
- Manufacturer: Belvedere 3100 Cameo Bowl or pre-approved equal
- Hair Interceptor: Zurn Z1175
J.R. Smith
Josam
10. Electric Water Cooler Wall-mounted (HC DF2): Self-contained, electric refrigerated wall-mounted water cooler. ADA compliant, NSF/ANSI 62 certified and meet the requirements of the Safe Drinking Water Act. Unit provides 8 gph of 50°F water at 90°F ambient and 80°F inlet water. Provide water filter accessory, selected by Architect. Remote Chiller: Halsey Taylor SJ5-Q. Drinking Fountain Locker Rooms (HC DF): Halsey Taylor HAC8FS-WF-QSS ADA Compliant.
- Manufacturer: Halsey Taylor HTV8-Q
Elkay
Sunroc

11. Electric water cooler – recessed (HC DF): ADA compliant oval shape B1-level, stainless steel fountain with integral chiller recessed in wall.

Manufacturer: Halsey Taylor OVL-II series bi-level SER-Q
Elkay
Sunroc

12. Shower Valve (SH, HC SH): Symmons Model 96-500-B30-X-L-V Temptrol 2000 pressure balancing valve with lever handle, internal volume control and stops, wall/hand shower with 5' metal hose, wall connection and flange, 30" slide bar and inline vacuum breaker, diverter with volume control and shower head with arm and flange. ADA compliant.

Manufacturer: Symmons
Speakman
Moen

Shower Valve: Symmons Model 96-1-X Temptrol Mixing Valve with shower head.

Shower Floor: Swanstone Model STS-3738, size 37" x 38". Color – Swanstone with ½" curb. ADA Complaint

13. Handicap Accessible Eye Wash/Shower Combinations (HC ESC)

Handicap Accessible Emergency Eye Wash/Shower Combination HAWS Model 8320CRP with 10" diameter polished stainless steel head and piping. Extra long ADA compliant, 48" max. above floor, pull down spreader rod attached to a stainless steel stay open ball valve. Emergency sign. ADA compliant.

Manufacturer: Haws
Fischer Hamilton
Speakman

Provide thermostatic mixing valve: Lawler 911E with cabinet

14. Three Compartment LAV (HC LAV3): Three person wash basin, ADA Compliant, Polyester resin bowl and pedestal, infrared sensors with stainless steel spray heads, thermostatic mixing valve. Set at 105°F, checkstop and strainer assemblies in stainless steel bottom enclosure with soap dispenser. Plug in transformer.

Manufacturer: Acorn 3793-SO-DV-MXT
Willoughby WAW-2333
Bradley

Two compartment LAV (HC LAV2): Similar to 3

Manufacturer: Acorn 3792-SO-DV-MXT
Willoughby WAW-2322
Bradley

15. Lab Sink (LS-ANT): Epoxy Resin Single Basin Drop-In Sink, 24" x 16" x 6" deep. ADA compliant. Complete with strainer, P-trap and overflow. Chrome plated, brass angle stops with loose key operator. Add acid tank and vac. breakers. HC rim height 34", knee clearance 27"H, 30"W, 19"Deep
- Manufacturer: Sheldon Laboratory Systems or pre-approved equal.
- Faucet: Sheldon Labs Unimix Hot & Cold Water Only
- Insulation: PROVIDE Truebro Insulation Kit on all handicap sinks.
HW & Drain pipes under Handicapped
- Point of Use Acid
Neutralizing Tank: Orion Style 8 Point of Use 1-1/2 gallons
16. Art Room Sink (AS): Just Mfg. Model NSFB-172, 72" L x 14" W x 12" Deep
One compartment stainless steel sink on legs with backsplash.
(2) 8" o.c. holes
- Manufacturer: Elkay
Just
Dayton
- Faucet: (2) Elkay Model LK940AT08L2H 8" o.c.
17. Insulation Kit: Truebro insulation kit models 102W & 105W
Install on all handicapped sinks
18. Solids Interceptor (SI): Cast aluminum body with sediment bucket and removable stainless steel screens. Install where indicated on plans.
- Manufacturer: Wade 5730
J.R. Smith 8760
Zurn Z1176
19. Scrub Sinks: Three station stainless steel sinks with sensor operated goose neck faucets, thermostatic mixing valves.
- Manufacturer: Acorn 4103-MC-PDM-SA.
Future Health Concepts FHC 5596
Skytron
20. Hand Sink (Food Service): Eagle Group #HSA-10-FDP complete with splash mount gooseneck faucet, C-fold towel dispenser, soap dispenser and basket drain. Provide point of use thermostatic mixing valve (TV) on 140°F hot water supply. (Lawler #TMM1000)
- Manufacturer: Eagle
Elkay
Just

21. Wash fountain (HC WF): ADA compliant. Polyester resin bowl and pedestal, 4 station, stainless steel spray heads with infrared sensors, thermostatic mixing valve, checks, stops, strainers and flexible stainless steel supply hoses. 3/8" solenoids, plug in transformer. ADA rim height 34".

Manufacturer: Willoughby WAF - 4400
Bradley MF-2944
Acorn

22. Free-standing stainless steel sink (S3): Just mfg. Model NSFB-124 24" x 27" x 12" deep. One compartment stainless steel sink on legs with back splash.

Manufacturer: Elkay
Just
Dayton

Faucet: Elkay LK940AT08L2H 8" o.c.

23. Watercloset (W2) for student plumbing shop: floor mounted, flush tank, standard, vitreous china, 1.5 gpf low flow, elongated, pressure assisted siphon jet with chrome plated trip lever. Seat heavy duty solid plastic open front, chrome plated brass angle supply with loose key stop.

Fixture: American Standard "Cadet" 2292.100
Kohler "Wellworth" K-3458
Eljer "Preserver II" 091-4855 (gravity fed)

Seat: Olsonite 95
Church 9500C

2.09 WATER HEATING EQUIPMENT

1. General: Water heaters shall conform to all applicable A.S.M.E. Standards and if gas fired Design Certified by the A.G.A. under Volume II "Tests for Commercial Heaters for Delivery of 140 Degrees F. Water", approved by the National Sanitation Foundation, and in compliance with ASHRAE 90 (latest edition).
2. Water Heaters WH#1 and WH#2: P.V.I. model 800 P 250A-PV Power VT gas, vertical, single module, 250 gal. tank. Interior of tank shall be coated with polyshield. Units shall be complete with all standard equipment including P & T relief valve, drain valve, and warranty. Heater shall be capable of heating 800 gallons per hour at 100 degrees Fahrenheit temperature rise with 565,000 BTU's per hour ea. propane gas.

Manufacturers: PVI
Aerco
Fulton

3. Water Heaters WH#3 and WH#4 (Food Service): P.V.I. model 800 P 125A-PV Power VT, 565,000 BTU, 640 GPH@100°F temperature rise ea. 125 Gallon Capacity. Blower motor, circ. pump, gas train and air pump to be removed for installation.

Manufacturers: PVI
Aerco
Fulton

4. Domestic Water Blending Valve: All bronze thermostatic type and threaded connections.

Manufacturer: Lawler Model 802
Symmons
Leonard

2.10 PUMPS

1. Domestic hot water circulating pumps: UL listed, all bronze, in-line centrifugal pump, close coupled.

Manufacturer: Bell & Gossett PR series, 1/6 hp, 120V, 1 phase.

2. Circulator controllers: UL listed, automatic immersion aquastat, adjustable temperature range, and differential immersion well. Electrical rating 115 VAC.

Manufacturer: Honeywell L4006A.

3. Motor starters: UL listed, manual starting switch in NEMA 1 enclosure with "Hands-Off-Auto" selector switch. Refer to section 230513.

4. Air Compressors:

- a. In Garage B140 serving carpentry, electrical and plumbing shops shall be duplex 15 hp compressors mounted on 120 gallon receiver tank with control panel and desiccant dryer. Unit shall be capable of delivering 55 cfm @ 120 psi. 230v, 3ph.

Manufacturer: Ingersoll Rand UP6-15C-125/120-230-3
Air Dryer: Ingersoll Rand Drystar DS75

- b. On Equipment Platform B206 serving manufacturing shop shall be a 15 hp compressor mounted on 120 gallon receiver tank with integrated air dryer and control panel. Unit shall be capable of delivering 50 cfm @ 120 psi. 200v, 3ph.

Manufacturer: Ingersoll Rand UP6-15CTAS-150/120-200-3

- c. In Equipment Storage Room G107 serving auto shop shall be duplex 10 hp compressors mounted on 200 gallon receiver tank with control panel and desiccant dryer. Unit shall be capable of delivering 68 cfm @ 120 psi. 230v, 3ph. Control panel located remotely in auto shop.

Manufacturer: Saylor Beall X-755-200

5. Duplex Sump Pumps (SP1):

- a. Pumps: Goulds model 3885, Series WE0318M 1/3 HP, 208V, 1ph, 60CY, 1750 RPM, UL listed, submersible non-clog pumps with cast iron body, cast iron impeller, sealed oil-filled motor, stainless steel shaft, ceramic/carbon seal, heavy duty upper and lower ball bearings, sealed power cord and 2" threaded discharge. Capacity: 25 gpm at 20Ft. TDH.
- b. Controls: Goulds model A6-2012, automatic duplex control system panel with NEMA 1 steel enclosure, circuit breakers, magnetic starters, alternator circuit, run indicator lights, H.O.A. switches, terminal blocks and high water alarm circuit (Wired to BMS) with alarm bell, indicator light and silencing switch. Provide with four N.O. mechanical tilt float switches for off, lead, lag and high water alarm sequencing Warrick series M-BLU-20 provide tether tie-down and weight and an extra set of dry contacts for remote annunciation. Provide float switch mounting bracket Model FSB1.

6. PIT Covers: Federal style PF-1 square angle iron pit frame and steel cover, gas-tight, drilled for control wiring, 2" discharge and 3" vent connections. Coordinate cover size with size of pits.

7. Sump Pump (SP-2): Simplex Pump in basin. ½ HP, 110V, 1 ph.
Manufacturer: Little Giant 105 series.

2.11 INTERCEPTORS

1. Grease Interceptor

- a. Proceptor Model GMC 2000 grease and solids interceptor having a capacity of 2000 US gallons, or a pre-approved equal. The interceptor shall have a grease storage capacity of 1025 US gallons and a solids storage capacity of 850US gallons.
- b. The interceptor shall be designed to remove from process wastewater grease and other floatable material(s). The Proceptor model shall be designed to treat commercial effluent as a maximum gravity flow rate of 200 usgpm. The effluent shall have no degreasers, surfactants, or emulsifiers. The Proceptor system shall provide adequate treatment time to limit effluent discharge levels of non-emulsified solvent extractable matter of animal or vegetable origin to 100 PPM and total suspended solids (TSS) to 350 ppm.

- c. The interceptor shall minimize turbulence, promote centrifugal separation and settling and prevent re-suspension and scouring of collected materials. Temporary backwater conditions shall not cause trapped contaminants to be re-suspended or scoured from the interceptor. Each interceptor shall comprise two cells or chambers of circular cross section in the horizontal plane, providing integral baffling. Wastewater shall enter below the normal liquid level and tangential to the interceptor wall. The manufacturer shall provide each interceptor with cleanout, sample, and ventilation ports together with an extension collar and frame and cover to allow access for removal of grease and solids.
- d. The interceptor shall be of glass-fiber construction using a thixotropic polyester resin specifically for the manufacture of reinforced products. The resulting material shall be inert, non-corrosive and impervious to retained wastes. The interceptor shall be suitable for underground installation in a non traffic area with a concrete hold down pad and the rods and brackets. Provide vents and access covers and installed as per the manufacturer's recommendations.

Manufacturer: Proceptor
Containment Solutions
Xerxes, Inc.

2. Oil Interceptor

- a. Proceptor Model OMC-1000 or pre-approved equal. The separator shall be designed to remove from process wastewater oil and other floatable material(s), and sediment, sand and other settleable material(s). The effluent shall have no degreasers, surfactants, or emulsifiers. The Proceptor™ system shall provide adequate treatment time to limit effluent discharge levels of non-emulsified solvent extractable matter of mineral or synthetic origin to a maximum of 10 ppm and total suspended solids (TSS) to a maximum of 350 ppm to avoid penalties and retrofit as enforced by local pretreatment officials.

Manufacturer: Proceptor
Containment Solutions
Xerxes, Inc.

2.12 MISCELLANEOUS PLUMBING SPECIALTIES

- 1. Mechanical mixing valves (kitchen hand sink): bronze body, chrome plated, 3/8" inlet and outlet connections.

Manufacturer: Lawler Model 526
Symmons #4-10 series
Leonard

- 2. Water hammer arrestors: all stainless steel, mechanical-pneumatic type, hermetically sealed bellows, threaded inlet; 150 psi WWP. Use in lieu of air chambers on all supplies to fixtures.

Manufacturer: Watts SG series.
PPP SC Series
Josam

3. Air vent: bronze body, stainless steel trim and float, threaded inlet and outlet; 150 psi WWP.
Manufacturer: Sarco 13W series or pre-approved equal.
4. Pressure gauge - PG: direct mounting, liquid filled, constructed with non-corrosive internal mechanism, recalibrator adjustment, assembled on 4-1/2" black phenolic turret type case with blow out plug, gasket sealed glass faced with dial, 0 to 200 psig range. Gauge accurate to 1% of scale range.
Manufacturer: Terice 450LFB series or pre-approved equal.
 - a. Gauge valve: all bronze needle valve, 150 psi WWP.
5. Water Filter Scale Inhibitor: scale inhibitor water conditioner, constructed of high impact strength plastic for 125 psi WWP, equipped with integral by-pass and replaceable cartridge filter element, 1 to 6 gpm flow range. Equip on cold water make-up supply to all HVAC equip.
Manufacturer: Filterite SI-4 series or pre-approved equal.
6. Vacuum beaker (non-pressure type): brass body, silicone disc. To be used on lab & food service sinks.
Manufacturer: Watts 288 series.
Febco
T & S
7. Freeze proof hose bibb (FPHB): surface mounted wall hydrant with polished bronze face plate and bronze casing with "T" handle key and internal vacuum breaker. Size 3/4".
Manufacturer: Zurn Z-1310 series.
Smith 5609 series.
Wade 8600 series.

Hot & cold water FPHB: J.R. Smith 5560QT or pre-approved equal.
8. Hose bibb (HB): unfinished areas, bronze body, removable valve seat and stem assembly, threaded end and Watts NF8 vacuum breaker.
Manufacturer: Nibco #64 with Watts NF8 series or pre-approved equal.
9. Acid neutralization tank (ANT): Point of Use, 1-1/2 gallon capacity
Manufacturer: Orion Style 8, or pre-approved equal
PHIX Cartridge System
(provide media as required)
10. Expansion Tank: Precharged diaphragm-type vessel. 125 PSI, 240°F. 30 gallons.
Manufacturer: Bell & Gosset Model D-60V, or pre-approved equal

11. Compressed air quick connect couplings: Brass coupling.
Manufacturer: Rectus 14 KA series or pre-approved equal .
12. Air hose reel: Retractable air hose reel, spring loaded, corrosion resistant housing, 50 ft of 3/2" PVC hose with fitting, 12 month warranty.
Manufacturer: Reelworks Model #L816153-P
Install per manufacturer's instructions.
13. Expansion Joints: Fabricated weld on ends with limit rods, double end. Constructed of stainless steel.
Expansion Joints (water piping):
Manufacturer: JCM Industries JCM802 or pre-approved equal,
Expansion Joints (no-hub storm and sanitary):
Manufacturer: Wade 3900 NH, or pre-approved equal
14. ***Auto shop waste oil collection tank shall be Snyder Industries (or approved equal) #100500N89102 275 gallon capacity, double wall polyethylene construction, debris strainer basket and tank level indicator.***

2.13 ACCESS DOORS IN WALLS AND CEILINGS

1. At each valve, cleanout or plumbing device requiring access, furnish an access door for installation by other sections. Rigid construction with two hinges and a latch. In plenum ceilings, provide felt between the door and frame to make an airtight seal. Panels/doors shall be flush mounted, prime coated with rust inhibitive paint, concealed frame, flush screwdriver operated locks with metal cams and anchors as required. Refer to division 8 for additional requirements.
Access door sizes shall be:
12" X 12" at easily accessible items.
16" X 16" where partial body access is required.
24" X 24" where full body access is required.
Manufacturer: Milcor type M series.
Cesco series.
or pre-approved equal

2.14 TRACERS FOR FREEZE PROTECTION

1. To be provided on all new outdoor piping. (2) 16 AWG copper bus wires embedded in parallel in a self regulating polymer core that varies its power output to respond to temperature along its length. The system shall permit crossing of cable without overheating. The heater cable shall be covered by a radiation cross linked modified polyolefin dielectric jacket.

2. All components shall be U.L. listed. See Electrical Drawings for location.
3. Rating: Adequate to maintain minimum 40°F in lines protected.
4. Cable manufacturer: Raychem XL-Trace or the pre-approved equal of Chemelx.
5. Control: The heater cable shall have a self-regulating turn down factor of 90%.
6. Thermostat manufacturer: Chromalox Type PIT-15 raintight thermostat.
7. Form a loop and wrap tracer cable around piping, fittings and valves according to manufacturer's recommendations with the following required length of cable allowed for each size gate/globe valve or strainer as listed.

1" valve = 3'-0" tracer cable
4" valve = 8'-0" tracer cable
8" valve = 15'-0" tracer cable

Minimum watt density

<3":	5.0 watts/ft.
4":	5.0 watts/ft.
6":	8.0 watts/ft.
8":	(2) @ 5.0 watts/ft.
up to 14":	(2) @ 8.0 watts/ft.

For further installation details of cable and controls refer to manufacturer's recommendations

PART 3 - EXECUTION

3.01 GENERAL

1. Drawings are diagrammatic and indicate a general arrangement of work. General design concepts indicated must be followed or bettered. Do not scale drawings. Consult Architectural and Structural drawings for space conditions. Develop and submit coordination drawings as outlined in Section 230000.
2. Manufacturer's qualifications: firms regularly engaged in the manufacturer of fixtures, appliances, pipes and pipe fittings of types and sizes required, whose products have been in satisfactory use in similar service for not less than 5 years.
3. Material qualifications: shall conform to all local, state, and national/federal codes and regulations which may apply and nothing in these specifications shall be interpreted as an infringement of such codes or regulations.
4. Welding: qualify welding procedures, welders, and operators in accordance with ASME B31.1, or ASME B31.9, as applicable. Certify welding of piping work using Standard Procedure Specifications by, and welders tested under supervision of, National Certified Pipe Welding Bureau (NCPWB).

5. Brazing: certify brazing procedures, brazers, and operators in accordance with ASME Boiler and Pressure Vessel Code, Section IX, for shop and job-site brazing of piping work.

3.02 DELIVERY, STORAGE, AND HANDLING

1. Except for concrete, corrugated metal, hub-and-spigot, clay, and similar units of pipe, provide factory-applied plastic end-caps on each length of pipe and tube. Maintain end-caps through shipping, storage and handling, as required to prevent pipe-end damage, and eliminate dirt and moisture from inside of pipe and tube.
2. Where possible, store pipe and tube inside and protected from weather. Where necessary to store outside, elevate above grade and enclose with durable, waterproof wrapping.
3. Protect flanges and fittings from moisture and dirt by inside storage and enclosure, or by packaging with durable, waterproof wrapping.

3.03 ELECTRICAL CONNECTIONS AND WIRING

1. Power wiring to electrical devices shall be installed by Division **26**. The Plumbing Contractor shall be responsible to furnish all motor starters for installation by Division **26** and provide and install miscellaneous control and power wiring required by the equipment for proper and safe operation not specifically outlined in Division **26**.

3.04 EQUIPMENT IN OTHER DIVISIONS AND/OR BY THE OTHERS

1. Kitchen equipment shall be provided, set, assembled, and installed by Kitchen, Laboratory, Laundry, and Darkroom Contractor, except as noted below or on drawing.
2. Faucets and tailpieces and laboratory fittings shall be provided and set by other divisions. Piping connections shall be provided by Section 220000.
3. Section 220000 shall provide and/or install traps, stops, faucets, fittings, tailpieces, including any miscellaneous trim and/or components not furnished by others but required for safe and proper operation, and connect the service.
4. Obtain certified and approved prints of roughing drawings of equipment before starting work.
5. Coordinate and verify all equipment locations, connections, and equipment requirements with the Kitchen Contractor. Provide and install all piping and equipment necessary to operate all equipment properly and safely whether specifically shown or not.
6. All exposed piping, stops, cocks, and wastes which are visible to occupants shall be chrome plated.
7. Install gas piping, and gas piping specialties in accordance with NFPA 54, NFPA 58, and authorities having jurisdiction.

3.05 COORDINATION OF WORK

1. Carefully coordinate space requirements with other trades to insure that all materials can be installed in spaces allotted thereto, including finished suspended ceilings.
2. Prepare and submit coordination drawings as outlined in section 230000.
3. Provide and install concrete housekeeping pads for all floor mounted plumbing equipment.

3.06 PIPING GENERAL

1. The word "piping" in this Specification shall mean pipe, fitting, flanges, nipples, and valves. Install underground piping as soon as possible so that trenches may be closed as quickly as possible.
2. No piping shall be covered until tested approved by the Authorities having jurisdiction.
3. Install all piping in correct relation thereto and the finished grades indicated on the drawings, and as required for coordination.
4. All piping shall be run perpendicular and/or parallel to floors, interior walls, etc. Piping and valves shall be grouped neatly and shall be run as to maximize headroom or passage clearance. All valves, controls and accessories concealed in furred spaces and requiring access for operation and maintenance shall be arranged to assure the use of a minimum number of access doors.
5. All pipe lines made with screwed fittings must be provided with a sufficient number of flanges and/or unions to allow for easy and convenient dismantling of the system without breaking fittings.
6. Check the drawings for space limitations permitted for the installation of piping such as shafts, chases, and furred ceilings.
7. All piping shall run concealed in furred spaces of occupied areas or chases wherever construction permits. Contractor shall obtain permission from the Contracting Officer to run any exposed pipes.
8. All pipes shall be reamed to full area before installation and blown clear of chips and dirt. With threaded pipes apply compound to the male thread only.
9. Cap all pipe and equipment outlets during construction and keep lines and inside of equipment free of foreign materials. Provide for expansion without warping or dislocating lines or straining connected equipment. Install piping to clear building construction and to avoid interference with other work.
10. Provide and erect in a workmanlike manner, according to the best practices of the trade, all piping shown on the drawings or required to complete the installation intended by these specifications.

11. The drawings indicate schematically the size and location of piping. Piping shall be set up and down and offset as required to meet field conditions.
12. This Contractor shall inform himself from the general construction specifications and plans, of the exact dimension of finished work and of the height of finished ceilings in all rooms where equipment or pipes are to be placed and arrange his work in accordance with the schedule of interior finishes, as indicated on the architectural drawings.
13. All piping below grade or building slab shall be coated with coal tar enamel.
14. Provide and install identification of piping and valves. Refer to other Division 23 Sections for installation requirements.
15. Provide and install additional pipe protection (ie. concrete encasement, and /or laying condition, bedding type and methods...) for underground piping subject to excessive loading by depth of bury, traffic or other sources.

3.07 PRESSURIZED PIPING

1. Exterior water piping shall be installed at least 5'-0" below grade to top of pipe.
2. Water piping shall be run free of traps and unnecessary bends. Any traps formed shall be provided with hose end drain valves with threaded cap and chain to completely drain the system.
3. Install water hammer arrestors on water systems in accordance with manufacturer's recommendations.
4. Provide section cut-off valves on all main branches or as shown. Pitch and valve all water piping for convenient drainage.
5. Wherever dissimilar metals are joined together an approved dielectric fitting shall be used.
6. Each sectional shut-off shall have a brass tag and copper wire with a number. A chart shall be made up for each system setting forth the number of valves and what fixture it controls. Chart to be placed in glass frame and hung in Mechanical Equipment Room. Refer to Section 230000 for piping and valve identification requirements.
7. Balance domestic hot water recirculation systems to maintain temperature throughout entire system.

3.08 DRAINAGE PIPE INSTALLATION

1. Run all soil, waste and vent piping shown or required by local codes. Piping shown is minimum and in accordance with State and Federal codes. If local codes require additional venting or larger sizes, same shall take precedence.

2. Make all connections through traps. Each trap to be vented, either by circuit, loop, or individual vent, as required, but not less than shown, or as required by local code.
3. Install exterior underground sanitary and storm drainage piping at least 48 inches below grade to top of pipe unless otherwise specifically indicated.
4. Vent pipes shall be graded to free themselves of any water or condensation. Pitch vents not less than 1/8" per foot up toward stack.
5. Install exterior cleanouts with an 18" square x 6" thick concrete apron.
6. Pitch horizontal storm water and drains within or buried under the building not less than 1/8" per foot unless otherwise indicated on drawings.
7. Pitch horizontal sanitary and waste piping at 1/2" per ft. slope for piping 1-1/2" or less; 1/4" per ft. slope for piping 2" diameter; and 1/8" per ft. slope for piping 3" to 6" diameter.
8. Piping shall be laid true to line and grade as shown on the drawings, and in such a manner that a true and even surface at the invert is made over joints and throughout the entire length of the line. Piping shall be graded by the tripod level and measuring rod method assuring a uniform slope of the pipe.
9. All underground piping shall be laid on 6" sand and backfilled with clean fine earth compacted to 12" above pipe. Complete backfill with available earth free of large boulders and sharp rocks. Tamp backfill in 6" elevations and overfill to allow for settlement.

3.09 PIPING SUPPORT

1. General
 - a. Refer to Sections 230000, 230523, and 232000 for general requirements.
 - b. Protection shields shall be provided under all horizontally insulated piping at each hanger.
 - c. Provide necessary structural members, hangers and supports of approved design to keep piping in proper alignment and prevent transmission of injurious thrusts and vibrations.
2. Horizontal piping support
 - a. Cast iron soil pipe shall be supported at not more than 5-foot intervals. Supports shall be of ferrous material.
 - b. Copper tubing shall be supported at approximately 6-foot intervals for piping 1-1/2" and smaller and 10-foot intervals for piping 2" and larger. Supports shall be of copper material.

3. Vertical piping support
 - a. Cast-iron soil pipe. Cast iron soil pipe shall be supported at not less than every story height and at its base. Supports shall be of ferrous material.
 - b. Bases of cast iron soil stacks shall be supported on concrete, or metal brackets attached to the building structure, or any other methods designed to eliminate stress at the base of stacks and leaders approved by the local administrative authority.
 - c. Copper tubing shall be supported at each story for piping 1-1/2" and over and not more than 4-foot intervals for piping 1-1/4" and smaller. Supports shall be of copper material.

3.10 INSULATION

1. Refer to section 230700 for installation requirements.

3.11 VALVES INSTALLATION

1. Refer to section 230523 for general requirements.
2. Do not install air gap backflow preventers in concealed spaces or in areas where splashing water will damage finishes. Provide and install an oversized copper funnel with air gap directly below RPD pressure relief port. Pipe funnel to spill as an indirect waste to an approved drain location.
3. Install all trap primer valves in an accessible location. Provide and install access panels and doors where required to gain access in concealed construction.

3.12 SLEEVE INSTALLATION

1. Refer to Section 230000 and 230523 for general requirements.
2. All piping through walls, floors or ceilings shall have sleeves and escutcheons.
3. All piping penetrating a slab on grade or foundation wall below grade and in contact with earth shall be provided with a poured in place schedule 80 galvanized steel water tight sleeve with integral water stop and seal equal to "link seal".
4. Furnish and set steel pipe sleeves of schedule 40 black steel for all locations of interior partitions, walls and floors providing at least 1/2" clearance between pipe insulation and sleeve or pipe and sleeve. Wall sleeves shall be smooth cut and set flush with finished walls. Floor sleeves shall extended 2" above the finished floor. Provide a two-piece chrome escutcheon where piping passes through walls or floors of finished spaces.
5. Fill void spaces between piping and pipe sleeves penetrating fire/smoke walls and floors with an approved UL listed and fire tested sealing material.

3.13 DRAIN AND CLEANOUT INSTALLATION

1. General: Provide and install all drains and cleanouts with 6# 24" x 24" PVC flashing.
2. Make all connections through traps. Each trap to be vented, either by circuit, loop, or individual vent, as required, but not less than shown, or as required by local code.
3. Cleanouts shall be installed at the base of all stacks, at all changes of directions greater than 45 degrees and in runs to provide means of cleaning lines at maximum 50' intervals.
4. Coordinate floor drain locations with respect to equipment housekeeping pads. Place drains such that edge of the floor grate extends no further than 2 inches from the side of the pad.

3.14 PLUMBING FIXTURES

1. The fixtures shall be furnished complete with chrome plating on exposed piping or trim. Provide anchor bolts, hangers, strainers, faucets and other incidental items furnished as standard. Provide loose key stops at every fixture. All supply fittings and exposed fixture trim shall be all brass, chrome plated.
2. All fixtures are to be new, free of cracks, blemishes or other imperfections and to be "acid-resisting" quality.
3. Set and properly connect all fixtures with hot and cold water, vent and drainage piping, as required and protect fixtures until acceptance and test. Clean all flush valves after two weeks of operation.
4. All piping through walls, floors or ceilings shall have sleeves and escutcheons.
5. Provide all fixture mounting supports and carriers as required to suit field conditions. Carriers and supports shall be floor mounted type except as noted.
6. Examine roughing-in work of potable water and waste piping systems to verify actual locations of piping connections prior to installing fixtures. Correct any incorrect location of piping, and other unsatisfactory conditions for installation of plumbing fixtures. Do not proceed with work until unsatisfactory conditions have been corrected in a manner acceptable to the engineer. All rough-in to plumbing fixtures shall conform to fixture manufacturer published rough-in dimensions, and requirements.
7. Adjust all plumbing fixtures, faucets and flush valves to meet the maximum water consumption requirements listed herein.

Water closets:	1.6 gallons per flush
Urinals:	1.0 gallons per flush
Lavatory:	0.5 gpm flow restrictor
Showers:	2.5 gpm

8. Upon completion of installation of plumbing fixtures and after units are water pressurized, test fixtures to demonstrate capability and compliance with requirements. Correct malfunctioning units at site, then retest to demonstrate compliance; otherwise, remove and replace with new units and proceed with retesting.
9. Inspect each installed unit for damage to finish. If damaged, restore and match finish to original at site to the satisfaction of the Architect/Engineer; otherwise, remove fixture and replace with new unit. Remove cracked or dented units and replace with new units.
10. Clean plumbing fixtures, trim, and strainers of dirt and debris upon completion of installation.
11. Adjust water pressure at drinking fountains, faucets, shower valves, and flush valves to provide proper flow stream and specified gpm.
12. Exercise care in handling of fixtures, trim, pipe, and fittings. Use tools designed to prevent damage to surface finishes.
13. Set fixtures level and uniformly, with connections at right angles to wall and properly centered. Lay out roughing accurately and in coordination with space and finish requirements. If field cut-outs and holes are required use proper cutting and drilling tools to maintain integrity of finished surface. Provide cut-out templates for countertop insert or undermount items.
14. Locate waste outlets and water supplies at constant horizontal levels, with waste outlet centered on fixture drain connection and water supplies spaced equally to right and left.
15. Support wall hung fixtures rigidly from building construction, not from piping, by means of concealed metal supporting members designed to carry weight of fixture under conditions of unusual loading, with no stress placed on waste connection or any other part of system.
16. Secure floor mount supports to slab. Secure wall mount supports to 1/4 inch thick metal backup plate secured to wall construction. Do not use wire, nails, or other makeshift devices to secure supporting members. Secure recessed and inserted items to supporting surface.
17. Use vandal-proof devices to secure fixtures, trimmings and fittings to deter unauthorized removal. Provide chrome plated brass washers and cap nuts for exposed bolt ends.
18. Provide escutcheons, threaded or held in place with threaded part or set screw, on piping and fixture supports protruding from wall or floor, and on visible connections to fixtures.
19. Make connection between integral trapped fixtures and drainage piping with an approved prepared gasket that shall be a germicide, absolutely gas and fume-proof, watertight, stainproof, containing neither oil or asphaltum, and which will not rot, harden, or dry under any extreme of climatic change, and must adhere on wet surfaces.

20. Use non-ferrous spacing devices to support and stabilize water piping.
21. Paint non-coated ferrous metal surfaces of fixtures, including brackets, hangers, and plates with prime coat of paint.
22. Upon completion of work, remove protective covers and thoroughly clean surfaces, traps and strainers. Check all items for proper operation. Tighten packings and retaining devices.
23. Adjust flush valves to provide minimum flow consistent with cleaning requirements of fixtures. Adjust supplies to provide adequate flow without splashing, and with flow rate of hot and cold water equal in velocity, except as otherwise required.

3.15 INDIVIDUAL SIZES OF BRANCHES TO FIXTURES

	COLD	HOT	WASTE	VENT
Water closets(tank)	1/2"	---	4"	2"
Water closets(flush val)	1-1/4"	---	4"	2"
Urinals (flush valve)	1"	---	2"	1-1/2"
Lavatories	1/2"	1/2"	1-1/2"	1-1/2"
Electric water coolers and drinking fountains	1/2"	---	1-1/2"	1-1/2"
Hose bibbs	3/4"	--	---	---
Clothes washer	1/2"	1/2"	2"	1-1/2"
Service sink or mop receptor	3/4"	3/4"	3"	1-1/2"
Sinks	1/2"	1/2"	2"	1-1/2"
Showers	1/2"	1/2"	2"	1-1/2"
Tubs	1/2"	1/2"	1-1/2"	1-1/2"

3.16 ROUGHING HEIGHTS

1. Above Finished Floor

Lavatories	31" to top of rim
Urinals	24" to top of rim
Water closets	15" to top of rim
Electric water coolers and drinking fountains	33" to top of rim
Hose bibbs	24" to bottom of spout
2. Handicap fixtures shall be set in accordance with ADA and local requirements.

3.17 EQUIPMENT IN OTHER DIVISIONS AND/OR BY OWNER

1. Kitchen equipment - Equipment will be provided and set by Kitchen Equipment Contractor (K.E.C.), except as noted below or on drawing.
2. Faucets and tailpieces will be provided but not set by K.E.C.

3. Plumber shall provide and install traps and stops and install faucets and tailpieces and connect the service as required.
4. Plumber shall obtain certified prints of roughing drawings of equipment before starting work.

3.18 GAS SYSTEMS

1. General: Conform to the requirements of NFPA 54.
2. Provide dirt trap, gas cock, and union at each connection to each piece of equipment.
3. Locate gas piping with adequate separation between electrical cables, equipment, and conduit.
4. Slope gas piping to low points without traps. Provide drips (pipe tee, nipple, and cap) at bottom of all vertical risers and drops.
5. Make branch connections to mains from top or side, not from bottom of main.
6. Extend unthreaded portions of piping at least 2 inches through finished wall surfaces, floors, ceilings and sleeves.
7. Provide and install gas shut-off valves for the proper and safe control of the system.
8. DO NOT locate gas valves in spaces used as air plenums.
9. Verification: before making a gas connection, verify that equipment is compatible with the type and pressure of gas being supplied.
10. Purging: purge gas to safe location.

3.19 PENETRATIONS THROUGH FIRE SEPARATIONS

1. Refer to specifications section 230000.3.14 for firestopping.

3.20 DISINFECTION OF POTABLE WATER SYSTEM

1. Potable water systems shall be disinfected in accordance with State and Local codes but by not less than one of the following methods before it is placed in operation.
2. The system, or part thereof, shall be filled with a solution containing 50 parts per million of available chlorine and allowed to stand 24 hours before flushing and returning to service.
3. The system, or part thereof, shall be filled with a solution containing 200 parts per million of available chlorine and allowed to stand 3 hours before flushing and returning to service.

3.21 TESTS

1. General: Test plumbing systems to satisfaction of Building Official. Do not close in, conceal, or cover up any plumbing work until it has been tested, inspected, and approved.
2. Flush piping, prior to testing, to remove foreign materials which may have entered during course of installation. Clean filters and strainers after flushing.
3. Test all piping except drainage and vent piping, including valves, fittings and joints hydrostatically at a pressure equal to at least 1-1/2 times the normal working pressure of the system under which it is to be used, but no less than 100 psig for a minimum of four hours. Blank off or remove all elements or equipment which may be damaged by the pressure. Open but do not back-seat valves. Inspect all joints and connections.
4. Test rough plumbing drainage and vent system with water or air at least as follows:
 - a. Water test: apply water test to drainage system either in its entirety or in sections. If applied to entire system, tightly close all openings in piping, except highest, and fill system with water to point of overflow. If system is tested in sections, tightly plug each opening except highest opening of section under test, and fill section with water. In testing successive sections at least upper 10 feet of next preceding section shall be tested, so that no joint or pipe in building (except uppermost 10 feet of system) shall have been submitted to a test of less than a 10 foot head of water. Keep water in system or in portion under test, for at least 15 minutes before inspection starts; system shall then be tight at all points.
5. Final test for gas and water tightness to be as follows:
 - a. Smoke test: fill all traps with water, and then introduce into the system a pungent thick smoke produced by one or more smoke machines. When the smoke appears at stack openings on the roof, they shall be closed, and a pressure equivalent to one inch water column shall be held for the test and inspection period.
6. Test all gas piping in accordance with NFPA 54 Section 4 with no leakage noted. Coordinate test procedure and requirements with local utility company.
7. Repair all leaks, defects or damage revealed by the results of the testing and re-test the system.
8. Do not insulate or conceal piping until the system has been tested and the results approved.
9. Perform tests in the presence of the Authority Having Jurisdiction. Notify Architect and/or Engineer.

10. Contractor is responsible for hiring a testing service to test the odorant levels of the above ground gas piping within the building and bear the cost of odorizing the gas piping if the odorant level in the piping system is not 0.10% or above gas in air. Contractor to forward the report to the owner.

3.22 TRAINING

1. Provide field training course for Owner's designated personnel. Provide video taping as required.
2. Training shall be provided for a total period of at least (8) hours of normal working time and shall start after the system is functionally complete but prior to final acceptance tests.
3. Field training shall cover all of the items contained in the operation and maintenance manuals.

3.23 RENOVATION OF AREAS NOT IN PRESENT PHASE OF PROJECT

1. In unrenovated areas, areas not in the present phase of work, that will require any kind of work including but not limited to the installation of new pipe, ductwork, and/or conduit entering, penetrating and/or passing through due to the phasing of the project. This contractor shall be responsible for the covering, moving, relocation, replacing and protecting of the owner's property.

The owner's property shall include but not be limited to furniture, equipment, furnishings, walls, floors and ceilings. This contractor shall be responsible for the cleaning of the room to the level and condition that the room was prior to the commencement of work. A representative of the owner shall review the existing condition of the room prior to work commencing. The cleaning shall include the whipping off, washing of the walls, floors, counter tops, desktops and any and all surfaces that are affected by the installation. After the work has been completed the owner's representative shall provide confirmation that the room has been cleaned to the level that it was prior to the work commencing.

The contractor shall be responsible for the moving, relocation and putting back in place any and all equipment that will be in the area of work.

If this contractor does not clean the room to the level to which it was found, the contractor shall pay any and all costs associated with the room clean up and cleaning.

If this contractor does not put back in place any and all equipment that will be in the area of work, the contractor shall pay any and all costs associated with the room set up.

END OF SECTION

SECTION 23 70 00 - AIR HANDLING AND TREATMENT

PART 1 - GENERAL

1.01 RELATED DOCUMENTS

1. Drawings and applicable provisions of the Contract, including General and Supplementary Conditions, Division 1 - General Requirements, and the General Provisions, Section 230000, govern the work of this Division.
2. Refer to specification 230000 2.1 A, B, C, D, E, F, and G for Video recording of material, equipment, operation and training .
3. Requirements given herein may be affected by other related requirements of the project specification. Correlation of the contract requirements is the responsibility of the contractor.

1.02 REFERENCES

1. Perform the work in accordance with the requirements of Section 230000, General Provisions, and with the provisions of all applicable codes and laws.
2. The installation and equipment is to conform to ANSI B9.1 Safety Code for Mechanical Refrigeration.
3. Air Moving and Conditioning Association (AMCA) Standards - Air performance of all air moving devices, shall be rated in accordance with AMCA Standard Test Code 210 and shall be licensed to bear the AMCA certified rating. Sound ratings specified in Section 230000 shall be obtained in accordance with the AMCA Standard 300. They shall be published in accordance with AMCA Standard 301, and the products should bear the AMCA sound certified ratings seal.
4. The quantity and performance criteria for each type of equipment is listed in the equipment schedules.

1.03 SUBMITTALS

1. Procedure
 - a. Prepare and make the submissions listed below and in Section 230000 in accordance with the procedure specified in Section 230000.
2. Shop Drawings
 - a. Air Handling Equipment and all Related Equipment
 - b. Fans
 - c. Fan Performance Curves

- d. Heating and cooling coils
 - e. Filters
 - f. Variable volume, constant volume, fan terminal units
 - g. Fan coil units
 - h. Cabinet and Unit Heaters
 - i. Dust Collection Equipment
 - j. Automobile Exhaust System
 - k. Fume Hood Exhaust System
 - l. Fume Extraction System
 - m. Air Door
3. System Testing
- a. Perform operating tests and instruct Owner's personnel as specified in Section 230000. Produce and maintain ventilation and air conditioning under operating criteria determined in advance by agreement with the Architect.

PART 2 - EQUIPMENT

2.01 GENERAL REQUIREMENTS

- 1. Construct all apparatus of materials suitable for the conditions encountered during operation.
- 2. All factory applied acoustical and thermal insulation, including facing and adhesives, sealants and paint, to be fire-resistant or non-combustible, and shall conform to the requirements of NFPA and local codes.
- 3. Construct all equipment in accordance with requirements of the local and state codes. Construct all pressure vessels that fall within the scope of ASME Code for unfired pressure vessels to conform to the code and bear the code stamp. Furnish three copies of National Board Inspection and Test Report.
- 4. Match and balance all system components to achieve compatibility of equipment for satisfactory operation and performance throughout the entire operating temperature and control range.
- 5. Provide all controls, wiring, piping, valves, tubing, accessories and other components necessary to make a complete operating assembly.
- 6. Test and rate all fans in accordance with the standards of AMCA. All fans must bear the AMCA rating seal.

7. Mount grease fittings directly on bearings unless the bearings are not visible or inaccessible. Then provide easily accessible extensions to bearing lubrication fittings.
8. Balance all fan wheels and other moving components statically and dynamically. Drill all fan shafts on the center line to receive a tachometer point.
9. Submit to the Engineer for approval complete curves of fan performance at the operating speed.
10. Provide coil covers on all coil headers which are installed outside of the air stream.
11. All filters shall be U.L. Class I.
12. Certify unit performance in accordance with ARI standard 410-72.
13. Submit to the Engineer for approval complete sound power data at the operating speed.
14. Motors to be premium high efficiency type with guaranteed minimum efficiency rated in accordance with IEEE standard 112, method B. Refer to Specification Section 230513 for required motor efficiencies and acceptable manufacturers.
15. Fans scheduled for variable speed duty shall be equipped with motors compatible with and specifically designed for variable speed operation. Coordinate with the manufacturer of the variable speed drive as specified in Section 230513.

2.02 ROOFTOP AIR HANDLING UNIT (AC-1, 2, 3, 4, 5, 6, 11, 13 & HV-1)

1. Description
 - a. Air Handler - Factory assembled and tested; designed for roof or slab installation; and consisting of chilled water cooling coils, steam heating coils, fans, energy recovery section, filters, starters, disconnects, dampers and damper operators.
2. Construction:
 - a. Unit shall be completely factory assembled, piped and wired and shipped in one section.
 - b. Unit shall be specifically designed for outdoor roof top application with a fully weatherproof cabinet.
 - c. All cabinet walls, access doors, roof and floor shall be a high performance composite panel constructed with G90 galvanized steel on both sides and a closed cell polyurethane foam interior core providing a rigid, impact resistant surface.

- 1) The walls of the coil and air tunnel compartments shall be 2 inches thick with a minimum R value of 12.5.
 - 2) The roof of the air tunnel compartments shall be sloped at a minimum of ¼ inch per foot and shall be an average of 2 ½ inches thick and an R value of 15.7.
 - 3) The entire base or floor shall be 1 inch thick with a minimum R value of 6.25.
 - 4) The access doors shall be 2 inches thick with a minimum R value of 12.5. The perimeter cross section shall be stepped to allow an overlap of the panel wall and compression of a full perimeter gasket within the cabinet panel wall.
 - 5) The foam shall have a minimum density of 2 pounds per cubic feet.
 - 6) All foam material shall be tested in accordance with ASTM D-1929 for a minimum flash ignition temperature of 610 degrees F.
 - 7) All panels shall have a thermal break with no metal path from inside to outside.
- d. Paint finish shall be capable of withstanding at least 2000 hours, with no visible corrosive effects, when tested in a salt spray and fog atmosphere in accordance with ASTM B 117-95 test procedure.
- e. Unit specific color coded wiring diagrams shall match the unit color coded wiring and will be provided in both point-to-point and ladder form.
- f. Diagrams shall also be laminated in plastic and permanently affixed inside the control compartment.
- g. Access to filters, heating and cooling sections, and other items needing periodic checking or maintenance shall be through hinged access doors with quarter turn lockable latches. Door fastening screws are not acceptable. The blower access door shall be bolted closed.
- h. Access doors shall have stainless steel hinges and full perimeter gasketing.
- i. All openings through the base pan of the unit shall have upturned flanges of at least 1/2" in height around the opening through the base pan.
- j. Air side service access doors shall have rain break overhangs.
- k. Unit shall have decals and tags to indicate unit lifting and rigging, service areas and caution areas. Installation and maintenance manuals shall be supplied with each unit.

1. Unit shall be furnished with 304 stainless steel drain pans.

3. Supply Fans:
 - a. The fan shall be direct drive single width single inlet un-housed airfoil centrifugal, plenum fans. Supply fans shall have all aluminum construction. Each air handler shall be equipped with a minimum of two independent direct drive supply fans; each fan to have its own motor and VFD. Fans attached to 1760 rpm motors shall be rated for a minimum of 1800 RPM maximum speed. Fans attached to 1170 rpm motors shall be rated for a minimum of 1200 RPM maximum speed. Direct drive fans shall be directly connected to and supported by the motor shaft. Motor bearings shall be rated for 200,000 hours service and shall have external lubrication connections. Fan(s) and motor(s) shall be dynamically balanced, and the entire fan assembly mounted on rubber isolators. Supply air shall be from the bottom of the cabinet. Motors shall be premium efficiency inverter rated only.

4. Outside Air:
 - a. Shall be a fully modulating enthalpy-based economizer for control by others with a DDC signal. The outside air damper and return air damper assembly shall be constructed of extruded aluminum, hollow core, air foil blades with rubber edge seals and aluminum end seals. Damper blades shall be gear driven and designed to have no more than 15 CFM of leakage per sq. ft. of damper area when subjected to 2 in. w.g. air pressure differential across the damper. Damper motor shall be spring return to ensure closing of outdoor air damper during periods of unit shut down or power failure.

5. Additional Fan Sections:
 - a. Power Return Fans
Axial flow direct drive fans shall be constructed of a polymeric material with fiberglass reinforcement and adjustable blade pitch. Direct drive fans shall be directly connected to and supported by the motor shaft. Motor bearings shall be rated for 200,000 hours service and shall have external lubrication connections. Fan(s) and motor(s) shall be dynamically balanced. (For Variable Volume Systems VFD drive(s) shall be factory mounted and wired to the fan motor(s).)

6. Energy Recovery:
 - a. The rooftop unit shall have a factory mounted and tested energy recovery wheel(s). The energy recovery wheel(s) shall be mounted in a rigid frame containing the wheel drive motor, drive belt, wheel seals and bearings.
 - b. The energy recovery component shall incorporate a rotary wheel in an insulated cassette frame complete with seals, drive motor and drive belt.

- c. Total energy recovery wheels shall be coated with silica gel desiccant permanently bonded by a process without the use of binders or adhesives, which may degrade desiccant performance. The substrate shall be lightweight polymer and shall not degrade nor require additional coatings for application in marine or coastal environments. Coated segments shall be washable with detergent or alkaline coil cleaner and water. Desiccant shall not dissolve nor deliquesce in the presence of water or high humidity.
- d. The wheel shall be wound continuously with one flat and one structured layer in an ideal parallel plate geometry providing laminar flow and minimum pressure drop-to-efficiency ratios. The layers shall be effectively captured in stainless steel wheel frames or aluminum and stainless steel segment frames that provide a rigid and self-supporting matrix.
- e. Wheels shall be provided with removable energy transfer matrix. Wheel frame construction shall be a welded hub, spoke and rim assembly of stainless, plated and/or coated steel and shall be self-supporting without matrix segments in place. Segments shall be removable without the use of tools to facilitate maintenance and cleaning. Wheel bearings shall be selected to provide an L-10 life in excess of 400,000 hours. Rim shall be continuous rolled stainless steel and the wheel shall be connected to the shaft by means of taper locks.
- f. All diameter and perimeter seals shall be provided as part of the cassette assembly and shall be factory set. Drive belts of stretch urethane shall be provided for wheel rim drive without the need for external tensioners or adjustment.
- g. The energy recovery cassette shall be an Underwriters Laboratories Recognized Component for electrical and fire safety. The wheel drive motor shall be an Underwriters Laboratory Recognized Component and shall be mounted in the cassette frame and supplied with a service connector or junction box. Thermal performance shall be certified by the manufacturer in accordance with ASHRAE Standard 84, Method of Testing Air-to-Air Heat Exchangers and ARI Standard 1060, Rating Air-to-Air Energy Recovery Ventilation Equipment. Cassettes shall be listed in the ARI Certified Products
- h. The exhaust fan(s) shall be backward inclined type. Fan(s) and motor(s) shall be dynamically balanced. A back draft damper shall be included with the exhaust fan. Outside air filters shall be 4" thick fiberglass pleated with an ASHRAE efficiency of 30%.
- i. Exhaust fan motors shall be premium efficiency inverter rated only. Motors shall have ball bearings rated for 200,000 hours service and external lubrication connections.
- j. Each unit shall be fitted with two independently operable fans for reliability and redundancy.

7. Filters:
 - a. Filters shall be 4" thick fiberglass pleated filters with an ASHRAE efficiency of 65% and a MERV rating of 11.
 - b. 5/16" lint screen pre filters upstream of the standard filters
 - c. Clogged filter switch
 - d. Direct dial reading Magnehelic gauge mounted in the controls compartment.
8. Cooling Coils (not on HV-1):
 - a. Shall be copper tube with aluminum fins mechanically bonded to the tubes.
 - b. Chilled water coil fin design shall be sine wave rippled.
 - c. Drain pan(s) shall be fabricated of 304 stainless steel.
 - d. Coils shall have galvanized steel end casings.
 - e. Coils shall be furnished with a double sloped drain pan for the positive drainage of condensate.
 - f. A drain connection shall be provided on each side of the unit. The manufacturer shall provide a P-trap condensate drain fitting for field installation to the drain connections.
 - g. Provide space for future cooling in the heating and ventilation only units.
9. Glycol Hot Water Heating Coils
 - a. Coils shall be certified in accordance with AHRI Standard 410 and be leak tested.
 - b. Coil shall be constructed of copper tubes with aluminum fins mechanically bonded to the tubes and galvanized steel end casings. Fin design shall be sine wave rippled.
 - c. Coil shall be located in the reheat position downstream of the supply fans.
 - d. Control valves shall be field supplied and field installed.
10. Controls:
 - a. Field Installed DDC Controls – refer to Section 230923.

11. Power Option:
- a. Unit shall be provided with a factory installed and wired internal disconnect.
 - b. Unit shall be provided with a factory installed and wired 115 volt, 15 amp ground fault service receptacle powered with a 1.5 KVA transformer.
12. Roof Curbs
- a. Roof curbs shall be constructed of minimum 14 ga. galvanized steel exterior. Curbs are to be fully gasketed between the curb top and unit bottom using 1.5” thick neoprene foam isolation gasket, with the curb providing full perimeter support, cross structure support and air seal for the unit. Curb gasketing shall be furnished within the control compartment of the rooftop unit to be mounted on the curb immediately before mounting of the rooftop unit.
 - b. Curb shall conform to the applicable seismic code, as required by Section 230000.
 - c. Curb shall be equipped with 2” deflection spring and rubber isolation. Refer to Section 230548 for requirements.
 - d. Curb shall be solid bottom with 2” double wall construction with perforated galvanized metal interior and acoustical fill between inner and outer wall on all sides and bottom.
 - e. Curb supplier shall submit acoustical performance analysis showing unit fan performance by octave band and effect of curb and duct appurtenances on room acoustic level.
13. Manufacturer: Model/Series
- | | | |
|----------|----|----------------|
| AAON | RN | |
| Trane | | Climate Master |
| Annexair | | ERP |

2.03 Rooftop Air Handling unit (AC-7, 8, 9, 10A, 10B, 12, 15, 16, HV-2, HV-3 & HV-4)

- 1. Description: Factory assembled and tested; designed for roof or slab installation; and consisting of chilled water coil, steam coils exhaust fan), return fans, filters, electrical starting gear and appurtenances, dampers and damper operators.
- 2. Construction:
 - a. Unit shall be completely factory assembled, piped and wired and shipped in one section.
 - b. Unit shall be specifically designed for outdoor rooftop application with a fully

weatherproof cabinet.

- c. Cabinet shall be constructed entirely of G90 galvanized steel with the exterior constructed of 20 gauge or heavier material.
- d. Paint finish shall be capable of withstanding at least 2500 hours, with no visible corrosive effects, when tested in a salt spray and fog atmosphere in accordance with ASTM B 117-95 test procedure. Unit exterior shall be "Gray" in color.
- e. The unit roof shall be sloped or cross-broken to assure drainage.
- f. Unit specific color coded wiring diagrams shall match the unit color coded wiring and will be provided in both point-to-point and ladder form.
- g. Diagrams shall also be laminated in plastic and permanently affixed inside the control compartment.
- h. Access to filters, blower, heating section, and other items needing periodic checking or maintenance shall be through hinged access doors with quarter turn handles. Door fastening screws are not acceptable.
- i. Access doors shall have full-length stainless steel hinges and full perimeter gasketing.
- j. All openings through the base pan of the unit shall have upturned flanges of at least 1/2" in height around the opening through the base pan.
- k. Air side service access doors shall have rain break overhangs.
- l. All air tunnel doors on 16-30 ton model sizes shall be 1" thick high performance composite panel constructed with G90 galvanized steel on both sides and a closed cell polyurethane foam interior core with a minimum R value for the doors of 6.25.
- m. Control cabinet doors on 16-30 ton model sizes and all access doors on 2-15 ton model sizes shall have an internal metal liner to protect the 1/2" thick, 1 1/2 lb. density fiberglass door insulation.
- n. The interior air side of the cabinet on 2-15 ton models shall be entirely insulated on all exterior panels with 1" thick, 1 1/2 lb. density fiberglass insulation enclosed by double wall galvanized insulation liners.
- o. Unit shall have decals and tags to indicate unit lifting and rigging, service areas and caution areas. Installation and maintenance manuals shall be supplied with each unit.
- p. Unit shall be furnished with 304 stainless steel drain pans.

3. Supply Fan:
 - a. Blower shall be entirely self-contained on a slide deck for service and removal from the cabinet.
 - b. All belt drive blowers shall have backward inclined blades.
 - c. Adjustable V-belt drive shall be provided with a minimum rating of 140% of the motor nameplate brake horsepower when the adjustable pulley is at the minimum RPM.
 - d. Blowers, drives and motors shall be dynamically balanced.
 - e. VFD drive(s) shall be factory mounted and wired to the fan motor(s).
 - f. Motors shall be premium efficiency inverter rated only. Motors shall have ball bearings rated for 200,000 hours service and external lubrication connections.

4. Outside Air Management:
 - a. Units shall have a 0-100% economizer consisting of a motor operated outdoor air damper and return air damper assembly constructed of extruded aluminum, hollow core, airfoil blades with rubber edge seals and aluminum end seals. Damper blades shall be gear driven and designed to have no more than 15 CFM of leakage per sq. ft. of damper area when subjected to 2" w.g. air pressure differential across the damper. Damper motor shall be spring return to ensure closing of outdoor air damper during periods of unit shut down or power failure. Barometric relief dampers shall be provided as part of the economizer option.
 - 1) Economizer shall be furnished with a DDC actuator for control by others.
 - b. Power Exhaust/Relief Fans (Where No Energy Recovery is Scheduled)
 - 1) Shall use belt drive backward inclined fan(s).
 - 2) The control shall be on-off (with a VFD factory mounted and wired to the fan motor).
 - 3) Exhaust air relief dampers shall be sized for 100% relief.
 - 4) Fan(s) and motor(s) shall be dynamically balanced.
 - 5) Motors shall be premium efficiency inverter rated only. Motors shall have ball bearings rated for 200,000 hours service and external lubrication connections.

5. Energy Recovery:
- a. Where scheduled on the drawings, the rooftop unit shall have a factory mounted and tested energy recovery wheel. The energy recovery wheel shall be mounted in a rigid frame containing the wheel drive motor, drive belt, wheel seals and bearings.
 - b. The energy recovery component shall incorporate a rotary wheel in an insulated cassette frame complete with seals, drive motor and drive belt.
 - c. The total energy recovery wheel shall be coated with silica gel desiccant permanently bonded by a process without the use of binders or adhesives, which may degrade desiccant performance. The substrate shall be lightweight polymer and shall not degrade nor require additional coatings for application in marine or coastal environments. Coated segments shall be washable with detergent or alkaline coil cleaner and water. Desiccant shall not dissolve nor deliquesce in the presence of water or high humidity.
 - d. The wheel shall be wound continuously with one flat and one structured layer in an ideal parallel plate geometry providing laminar flow and minimum pressure drop-to-efficiency ratios. The layers shall be effectively captured in stainless steel wheel frames or aluminum and stainless steel segment frames that provide a rigid and self-supporting matrix.
 - e. Wheels greater than 25" in diameter shall be provided with removable energy transfer matrix. Wheel frame construction shall be a welded hub, spoke and rim assembly of stainless, plated and/or coated steel and shall be self-supporting without matrix segments in place. Segments shall be removable without the use of tools to facilitate maintenance and cleaning. Wheel bearings shall be selected to provide an L-10 life in excess of 400,000 hours. Rim shall be continuous rolled stainless steel and the wheel shall be connected to the shaft by means of taper locks.
 - f. Wheels 25" and less in diameter shall be provided with a monolithic removable energy transfer matrix. Wheel frame construction shall be a welded hub and rim assembly of stainless, plated and/or coated steel. Monolithic wheel shall be removable and replaceable from the cassette frame when the cassette frame is taken out of the unit. Wheel bearings shall be selected to provide an L-10 life in excess of 400,000 hours. Rim shall be continuous rolled stainless steel and the wheel shall be connected to the shaft by means of taper locks.
 - g. All diameter and perimeter seals shall be provided as part of the cassette assembly and shall be factory set. Drive belts of stretch urethane shall be provided for wheel rim drive without the need for external tensioners or adjustment.
 - h. The energy recovery cassette shall be an Underwriters Laboratories Recognized Component for electrical and fire safety. The wheel drive motor shall be an Underwriters Laboratory Recognized Component and shall be mounted in the

cassette frame and supplied with a service connector or junction box. Thermal performance shall be certified by the manufacturer in accordance with ASHRAE Standard 84, Method of Testing Air-to-Air Heat Exchangers and ARI Standard 1060, Rating Air-to-Air Energy Recovery Ventilation Equipment. Cassettes shall be listed in the ARI Certified Products

- i. The exhaust fan(s) shall be backward inclined type. Fan(s) and motor(s) shall be dynamically balanced. A back draft damper shall be included with the exhaust fan. Outside air filters shall be 4" thick fiberglass pleated with an ASHRAE efficiency of 30%.
 - j. Exhaust fan motors shall be premium efficiency. Motors for use with a VFD shall be premium efficiency inverter rated only. Motors shall have ball bearings rated for 200,000 hours service and external lubrication connections.
6. Filters:
- a. 4" thick fiberglass throwaway filters with an ASHRAE efficiency of 65% and a MERV rating of 11.
 - b. 5/16" lint screen pre filters upstream of the standard filters.
 - c. Clogged filter switch
 - d. Direct dial reading Magnehelic gauge mounted in the controls compartment.
7. Glycol Hot Water Heating Coils
- a. Coils shall be certified in accordance with AHRI Standard 410 and be leak tested.
 - b. Coil shall be constructed of copper tubes with aluminum fins mechanically bonded to the tubes and galvanized steel end casings. Fin design shall be sine wave rippled.
 - c. Coil shall be located in the reheat position downstream of the supply fans.
 - d. Control valves shall be field supplied and field installed.
8. Chilled Water Coils (not on HV-2, -3 or -4):
- a. Unit shall be provided with a 4 (6) row chilled water cooling coil, with copper tubes with aluminum fins mechanically bonded to the tubes.
 - b. Chilled water coil fin design shall be sine wave rippled.
 - c. Chilled water coils shall have galvanized steel end casings.
 - d. Chilled water coils shall be furnished with a double sloped drain pan for the

positive drainage of condensate.

- e. Chilled water coil drain pan shall be fabricated of 304 stainless steel.
- f. Provide space for future cooling in the heating and ventilation only units.

9. Controls: Field Installed DDC Controls – Refer to Section 230923.

10. Power Accessories:

- a. Unit shall be provided with a factory installed and wired 115 volt, 12 amp ground fault service receptacle powered by a 1.5 KVA transformer.
- b. Unit shall be provided with a factory installed and wired internal disconnect.

11. Roof Curbs

- a. Roof curbs shall be constructed of min 14 ga. galvanized steel exterior. Curbs are to be fully gasketed between the curb top and unit bottom using 1.5” thick neoprene foam isolation gasket, with the curb providing full perimeter support, cross structure support and air seal for the unit. Curb gasketing shall be furnished within the control compartment of the rooftop unit to be mounted on the curb immediately before mounting of the rooftop unit.
- b. Curb to be double wall solid bottom acoustical design min 2” thick with perforated galvanized interior enclosing acoustical batting over all sides and bottom.
- c. Curb to be fitted with 2” deflection (min) spring isolation rail. Refer to Section 230548 for requirements.
- d. Entire assembly shall be certified to meet prevailing local seismic code. Vendor to provide certification documents stamped and signed by an engineer licensed in CT.

12. Manufacturers:	Model/Series:
AAON	RN
Trane	Climate Master
Annexair	ERP

2.04 ROOFTOP AIR HANDLING UNIT – 100% OUTSIDE AIR (AC-14)

1. General:

- a. Units shall be completely cleaned and vacuumed. All pipe and duct openings shall be plugged or covered in such a manner to prevent entrance of foreign matter. Units shall be delivered with factory installed shipping skids or lifting lugs. Items/Components that are shipped loose shall be packed in separate protective packages.

- b. The Air Handling Unit sections shall be shrink-wrapped prior to shipment using 10 mil. plastic sheet. All openings shall be suitably protected during shipping. Prior to the shipment from the factory, the manufacturer shall inspect the insides of each unit and clean inside surfaces that have visual appearance of oil, dirt, dust, rust, chips or grease.
- c. Store Air Handling Units in safe, clean and dry place and away from construction traffic.

2. Unit Base

- a. The entire unit shall be assembled on 6" high Channel out of structural steel with integral cross support members designed to carry the component load. The base cross members shall be sized to keep the structural integrity of the base frame during rigging and handling. After construction the base shall be cleaned and painted with a rust inhibitor paint. The base frame shall have properly located lifting lugs, which are an integral part of the channel allowing ease of rigging and insuring the unit frame does not deflect more than 1 inch for 15 ft. of span.

3. Cabinet / Housing.

- a. The unit shall be constructed out of 2" thick wall and roof panels. The panel will be insulated with 2" thick – 3.5 lb/cft mineral wool insulation (Insulation to have facing erosion resistant up to 5000 fpm where there is a perf. liner). The panels' outer skin shall be made out of painted 18G Solid Satin Coat Steel Sheet in accordance with ASTM-653, Commercial quality, and inner skin to be 20G- G90. Fan Sections to have 20G G-90 Perf liner – 23%, 3/32" openings @3/16" staggered. The inner skin shall be hemmed on all four sides to eliminate any sharp edges. (Unhemmed inner skins are not acceptable) The panels are to be internally joined together with self tapping screws with 100% solid cross linked butyl preformed rubber sealant type Tremco 440 tape between each panel and then caulked to prevent water and air leakage. The housing panel deflections are limited to 1/200th of the span dimension while under positive and negative pressure.
- b. The exterior panels shall be fastened to the base through Rain Lip Type Z strip hemmed at the exterior end. (Unhemmed Z-strips are not acceptable) installed around the perimeter. The Z strips will be stitch welded to the base floor with Tremco 440 tape between Z strip and base of panel. This will be continuously caulked with Vulkem 116 gun grade polyurethane sealant conforming to US Federal & ASTM specifications in water and humid areas like drain pan & humidifiers, and with Thermoplastic Elastomeric sealant Tremco 830 sealant in general areas. Z strip to be mitred at time of assembly before being clamped into position for assembly. Sections or modules shall be designed to be fastened together in the field with closed cell neoprene gasketing.
- c. Coil Removable Panels: All coils shall have bolted removable panels to facilitate easy access and removal of coils. The panel shall be made similar to wall panels.

- d. Unit Floor: The unit floor shall be constructed of 16Ga G-90 galvanized steel sheet. The unit floor shall be screwed to the base channel. The supply air and return air openings shall have 2 inch duct connecting flanges. Underneath the unit, floor shall have 20 Gauge liner Steel Sheet in accordance with ASTM-653, Commercial quality, Hot dip Galvanized steel with G90 Zinc- Coating to Triple Spot test Method with 3" thick-3/4 lb/cft density unfaced fiberglass insulation behind.
 - e. Extruded Aluminum Frame Access Doors with one piece side mounted santoprene gaskets:
 - 1) Hinged access doors shall be wide enough to allow easy access for service maintenance and minimum of 18" wide. The door, frame & outer skin shall be of minimum 18 Gauge galvanized steel whereas inner skin shall be 20G G90. The door will be fitted with stainless steel Piano hinges and a minimum of two (2) Ventlock VL-260 Handles, the door gasket shall be of bulb type. Access doors shall be placed at locations as shown in the drawing and shall have 1/4" tempered wired reinforced windows 8" X 12" if indicated on the drawings. The doors will open inward or outward according to positive or negative pressure in the respective sections. Doors shall be fully gasketed with one piece santoprene gaskets installed on side of the frame. Gaskets installed at the edge is not acceptable. All doors shall be ETL Tested and have compliance to UL1995 safety standard for heating and cooling.
 - 2) Removable panels shall be provided for heating and cooling coils. Access doors and panels shall be of the same thickness and construction as the wall panels.
4. Coil Racks, Drain & Drip Pans.
- a. Drain pan shall be made out of 16 G Stainless Steel S/S 304 2B Finish material, continuously welded and positively sloped for drain on side as shown on the drawing with 1 1/2" NPT drain connection with a minimum depth of 3" at drain. Drain piping shall be 304 stainless steel with each drip pan individually piped to the drain pan.
 - b. For ease of removal the coil shall be supported on individual racks. The racks shall be made of formed 16Ga Galvanized steel channel. One side of the coil shall have a removable panel for coil pull out and removal and shall be designed to permit the removal of individual coil sections without disturbing remaining coils.
5. Inner skin at Drain Pan
- a. The inner skin at coil, drain pan section, humidifier section shall be 20G solid Hot Dip Galvanized Steel Sheet in accordance with ASTM-653, Commercial quality, G90 coating equivalent to Z275 measured in accordance with Triple Spot Test Method.

6. Paints: The exterior of the indoor unit shall be cleaned and painted with Amerlock 400 capable of 5% salt spray test of 3000 HOURS AS PER (ASTM B117), with a top coat of Amershield Polyurethane.
7. Magnehelic Filter Gauge: A differential Pressure Gauge for measuring the pressure drop across each filter bank shall be provided. The gauge shall be diaphragm-actuated dial type series 2000, 3 7/8" dia. white dial with black figures & graduations, 0 to 1" water gauge operating ranges and will have two static pressure taps and vent valves. Static Pressure taps shall be factory piped.
8. Filters
 - a. Filters shall be sized according to 500 FPM face velocity and include 2" prefilters
 - b. Pre Filter media shall have an average efficiency of 25-30% on ASHRAE Test Standard 52-76
 - c. Holding frames shall be face loading type, 16Ga galvanized steel and shall be equipped with gaskets and four spring type positive fasteners.
 - d. Filters shall be equal to Farr 30/30 and type 8 holding frames and springs.
9. Dampers & Louvers
 - a. Provide unit with factory mounted outside, relief and return air dampers (where required) of galvanized steel blades, with silicone blade seals in galvanized frame, in opposed blade arrangement with non-slip keyed connecting rods and linkages. Permanently secure damper blades on a single shaft with self-lubricating nylon bearings. Position damper blades across short air opening dimension. Maximum leakage shall not exceed 2 percent at 4 inch water gauge differential pressure when sized for 2000 fpm face velocity
 - b. Provide unit with factory mounted stationary drainable blade louvers where shown. Louvers frame shall be constructed from heavy gauge 6063-T5 aluminum 4" deep with a 0.081" nominal wall thickness. Blades: Drainable design, heavy gauge extruded 6063-T5 aluminum, 0.081 in. nominal wall thickness, positioned at 37° and 45° angles on approximately 4 in. centers. Birdscreen to be 3/4 in. x 0.051 in. flattened expanded aluminum in removable frame, inside mount (rear).
10. Centrifugal Fans
 - a. The fan shall be a Double-Width Double Inlet type designed with scroll housing and having aerodynamically designed spun inlet cones incorporating a non-overloading type backward inclined airfoil Aluminum blades continuously welded around all edges to a wheel shroud and heavy gauge reinforced steel back plate. The assembly shall have structural steel frame. The fan shall have inlet plate incorporating removable spun inlet cone designed for smooth airflow into the accompanying inlet retaining ring of the fan wheel.

- b. All wheels shall be statically and dynamically balanced on precision electronic balancer to a level of G6.3 (Per ANSI 2-19 or better). All shafts shall be solid steel accurately turned, ground, polished and ring gauged for accuracy. Shaft shall have first critical speed at least 1.35 times the maximum speed of the fan.
- c. All fans shall have heavy duty, grease lubricated, anti friction ball or roller bearing, self aligning, pillow block type bearing selected for minimum average life ABMA L50 of 200,000 hrs and fitted with regreasable fittings with option of extending the lube lines for easy re-lubrication.
- d. Each fan component shall be thoroughly degreased before application of rust-preventive blue primer. After complete assembly, a finished coat shall be applied to the assembly.
- e. Fan performance shall be based on test conducted in accordance with AMCA standard test code for air moving devices and shall be licensed to bear AMCA seal. Drives shall be V-belt and sized for 1.5 times the fan motor horsepower. The fan shall have an OSHA belt guard.

11. Chilled Water Cooling Coil.

- a. Primary surface shall be round seamless 5/8 inch O.D. by .020 inch thick copper tube on 1.5 inch centers, staggered in the direction of airflow. All joints shall be brazed. Secondary surface shall consist of .0075 inch rippled aluminum plate fins for higher capacity and structural strength. Fins shall have full drawn collars to provide a continuous surface cover over the entire tube for maximum heat transfer. Bare copper tube shall not be visible between fins and the fins shall have no openings punched in them to prevent the accumulation of lint and dirt. Tubes shall be mechanically expanded into the fins to provide a continuous primary to secondary compression bond over the entire finned length for maximum heat transfer rates.
- b. Casings shall be constructed of continuous galvanized steel. Coil side plates shall be of reinforced flange type. Coils shall have equal pressure drop through all circuits. Coils shall be circuited for counter flow heat transfer to provide the maximum heat transfer rates. Headers on coils shall be seamless copper tubing. The headers shall have intruded tube holes to provide a large brazing surface for maximum strength and inherent flexibility. Supply and return connections on water coils shall be copper with male pipe threads. The complete coil core shall be tested with 315 psig air pressure under warm water and be suitable for operation at 250 psig working pressures. Individual tube tests and core tests before installation of headers shall not be considered satisfactory. Water cooling coils shall be circuited for drain ability. Use of internal restrictive devices to obtain turbulent flow shall not be acceptable. Vents and drains shall be furnished on all water coils. Coils shall be rated in accordance with ARI.

- c. Coils shall be mounted in galvanized holding racks. Water coil supply and return connections shall be extended to the unit exterior. Water coil drain and vent connections shall be accessible from the interior of the Unit and shall not be extended through the unit casing. Cooling coils shall be mounted in an insulated pitched 304 stainless steel condensate pan.
12. Air-to-air heat exchanger
- a. Air-to-air heat exchanger shall be a stationary aluminum flat plate type. Heat transfer surface shall be formed aluminum plates 0.008" thick with enhanced surface corrugation for increased performance. Exchanger frame profiles shall be all aluminum with coated sheet metal end plates. Exchanger shall be capable of withstanding a pressure difference between airflows of up to 7.2" w.g. without deforming air passages. Unit shall be capable of operating in temperatures up to 190°F standard construction. Standard cell construction shall have a maximum cross contamination between airflows of 0.01% of total airflow. The entire cell shall be capable of being visibly inspected and cleaned as required.
13. Glycol Hot Water Heating Coils
- a. Coils shall be certified in accordance with AHRI Standard 410 and be leak tested.
 - b. Coil shall be constructed of copper tubes with aluminum fins mechanically bonded to the tubes and galvanized steel end casings. Fin design shall be sine wave rippled.
 - c. Coil shall be located in the reheat position downstream of the supply fans.
 - d. Control valves shall be field supplied and field installed.
14. Roof Curb: 12" high, insulated, made with minimum 14G galvanized steel sheet. Includes Z-strip for weatherproofing.
15. Vibration: The overall vibration level on any of the bearing housings on the fan and motor taken in horizontal, vertical or axial direction shall not exceed 0.10 in/sec peak to peak . Any discreet frequency shall not have an amplitude exceed 0.03 in/sec peak to peak. Any discreet frequency above 15 times the rotating speed shall not exceed 0.098 in /sec. All vibration spectra to be taken with a maximum frequency of 120,000 cycle
16. Casing leakage: Tests shall verify that casing leakage for air unit is less than 1% of design airflow when tested at 1.5 times fan shut off pressure. Determine leakage using the testing methods as described in SMACNA HVAC Air Duct Leakage Test Manual. Provide temporary sealing of openings as required for leakage testing.

17. Electrical Specification and Tests

- a. Wiring and Disconnect: The electrical panel shall be NEMA 3R rated and mounted on the unit exterior as shown on the General Arrangement Drawing. The electric panel shall consist of a non-fused disconnect, Electrical panels shall bear an ETL label. All wiring 120 volt and higher and wire size #8 and smaller shall be run in MC Cable. All wire size #6 and larger shall be run in EMT. Fan motors requiring wire run in EMT shall have a 2' length of seal tight at the motor junction box. Low voltage wiring shall use plenum cable, installed external to the conduit. Starter coils shall be 24 volt AC for contactors rated 75 amps or less and 120 volt AC for contactors rated greater than 75 amps.
- b. Lights & GFI Receptacle - Vapor tight lights shall be provided in access compartments as shown on the General Arrangement drawing. Lights shall be wired to a single switch on the unit exterior. A GFI receptacle shall be mounted next to the light switch. A separate 120 volt power connection shall be required at the GFI receptacle to provide power for the lights and receptacle.
- c. Controls: AHU manufacturer will factory mount all the controls including sensors & actuators to be supplied by temperature control contractors. These controls shall be wired and terminated to a termination strip at the outer casing of the AHU.
- d. Test: Energize and run test for not less than ½ hr all electrical components to prove satisfactory operation, and that all circuits are free from short circuits and unspecified ground. Each Variable speed drive unit shall be completely functionally tested under actual motor load. Test that the insulation resistance to ground of all non-grounded circuits is not less than one mega ohms at 1000 volts DC. Arrange to have units factory inspected and perform other testing as required to obtain ETL Label.

18. Testing & Commissioning

- a. Unit manufacturer shall provide the services of a trained technician to supervise the installation of the unit and to perform the start up of the unit. After the unit is installed, perform inspection, start-up and checkout of the equipment. Do not start up equipment until the following operations are complete:

19. Roof Curbs

- a. Roof curbs shall be constructed of min 14 ga. galvanized steel exterior. Curbs are to be fully gasketed between the curb top and unit bottom using 1.5" thick neoprene foam isolation gasket, with the curb providing full perimeter support, cross structure support and air seal for the unit. Curb gasketing shall be furnished within the control compartment of the rooftop unit to be mounted on the curb immediately before mounting of the rooftop unit.
- b. Curb to be double wall solid bottom acoustical design min 2" thick with perforated

galvanized interior enclosing acoustical batting over all sides and bottom.

- c. Curb to be fitted with 2" deflection (min) spring isolation rail. Refer to Section 230548 for requirements.

Entire assembly shall be certified to meet prevailing local seismic code. Vendor to provide certification documents stamped and signed by an engineer licensed in CT.

20.	Manufacturer:	Model:
	MAFNA Air Technologies Inc. 519-624-4622	Custom
	AAON	Custom Rooftop
	Cambridgeport	Custom Rooftop

2.05 GAS FIRED MAKEUP AIR HEATER

1. Unit shall be factory fabricated, direct fired makeup air unit, with: fan; motor and drive; filter; outside air damper; natural gas heating section; filter; access doors; remote control panel with indicator lights; fuel burning safety equipment; temperature control system; gas piping and control valve with ductstat; vented extension; interlock control panel with starter, fusing, interlock relay and transformer; and all accessories and hardware.
2. Unit shall be UL listed, and conform to requirements of ANSI Z83.4, NFPA 54 and the National Fuel Gas Code.
3. Cabinet - galvanized steel formed panels with external channel reinforcing. Finish external surfaces with primer base coat and finish coat of enamel.
4. Fan - centrifugal, forward curved type, double inlet. Wheel - keyed to steel shaft. Permanently lubricated bearings. All components exposed to the air stream shall be constructed of galvanized steel or coated with an enamel coating. Blower section to be fully insulated with UL listed Class 1 foil faced fiberglass insulation, 1" thick.
5. Bearings - self-aligning split pillow block with grease lines extended to the outside of the casing. Bearings shall be rated for a minimum of 200,000 hours.
6. Adjustable V-belt drives.
 - a. A complete matched set to transmit the power to the driven equipment; not less than two belts per drive. Provide one spare set of belts for each size drive supplied.
 - b. Sheaves: Adjustable plus or minus 10%. When motor is 15 HP or over, use companion type sheaves.
 - c. Belts: Reinforced rubber or neoprene.
 - d. Service rating: Not less than 200% of the maximum estimated load; greater if specified for particular apparatus.

- e. Minimum efficiency: 95%.
- 7. Motors - Premium efficiency type with guaranteed minimum efficiency as stated in Section 230513. General Electric Co. "Energy Saver" or the approved equal of Westinghouse or Marathon.
- 8. Burner
 - a. Burner shall be a direct fired, draw through type, consisting of non-clogging, stainless steel combustion baffles attached to a cast iron gas supply section with no moving parts. The burner shall be capable of 100% thermal efficiency, with a maximum turndown ratio of 30 to 1.
 - b. An ultraviolet flame detection system shall be used to prove flame.
 - c. A spark igniter shall be provided to initiate combustion.
 - d. Gas train shall consist of pressure regulator, solenoid gas valve, modulating gas valve, manual shut off, manifold pressure tap. Gas pressure regulator shall be factory set to regulate gas flow to main burner.
 - e. Ignition system shall be a stepped direct ignition system, with spark ignited proved pilot before full burner operation. System shall comply with ANSI Z83.4.
 - f. Electrical controls shall include motor contactor/overload, grounding lugs, terminal blocks, Heat/No Heat switch, flame safety device, airflow switch, transformer, modulating amplifier, ignition module, high temperature limit control, and temperature selector.
- 9. Accessories.
 - a. Intake section with 1" thick, UL listed, cleanable Class 2 filter.
 - b. A discharge sensor to measure discharge air temperature, and send signal to controller, for modulation of gas valve to maintain discharge temperature.
- 10. Manufacturer: Model/Series:
 - Greenheck DGX
 - Carroll Manufacturing Co. ARES
 - Trane DFOA

2.06 FANS: ROOF MOUNTED UTILITY SET

- 1. Roof exhaust fans shall be of the centrifugal belt-driven or direct-drive type as indicated on Drawings. Fans shall be of capacities and characteristics as scheduled on Drawings and specified herein.

2. Construction of the fan housing shall be of heavy-gauge aluminum.
3. All spun parts shall have a rolled bead for added rigidity and shall be specially spun so as to seal the pores of the aluminum providing greater resistance against oxidation and deterioration.
4. The fan wheel shall be all-aluminum of the centrifugal blower type featuring backward-inclined blades and a tapered inlet shroud. Wheels shall be statically and dynamically balanced. Inlet cone shall be aluminum and of the centrifugal blower type. Motor and drives shall be enclosed in a weathertight compartment, separate from the exhaust air stream. Air for cooling the motor shall be supplied to the motor compartment by way of an air passage from an area free of contaminated exhaust fumes. Motors shall be of the duty, permanently lubricated, sealed ball-bearing type. Drives shall be sized for 165 percent of motor horsepower capabilities and of the cast-iron type, keyed to the fan and motor shafts. Variable pitch drives shall be standard. Fan shaft shall be of steel construction, turned, ground, and polished to precise tolerances in relationship to the hub and bearings. Drive belts shall be of the oil-resistant, non-static, non-sparking type with life expectancy of over 24,000 hours.
5. Bearings shall be flanged and of the permanently lubricated, permanently sealed, ball-bearing type capable of over 200,000 hours bearing life. The entire drive assembly and wheel shall be removable, as a complete unit, from the support structure without disassembling the external fan housing. The complete drive assembly shall be mounted on rubber vibration isolation.
6. Fans shall be licensed to bear the AMCA ratings seal for air and sound performance.
7. Fans shall be furnished with pre-fabricated 12” roof curbs. Roof curbs shall have 2-inch raised cant strip and wood nailer. Curb shall be aluminum construction. Fans shall be furnished with automatic backdraft damper and weather hoods to protect motor and drive components.
8. Fans shall have chemical-resistant heresite finish and spark-proof construction.
9.

Manufacturers:	Model/Series:
New York Blower	GP
Greenheck	SWB
Loren Cook	CP Series

2.07 FUME HOOD EXHAUST FAN - HIGH PLUME LABORATORY EXHAUST

1. General
 - a. Base fan performance at standard conditions (density 0.075 Lb/ft³).
 - b. Fans selected shall be capable of accommodating static pressure and flow variations of +/-15% of scheduled values.
 - c. Each fan shall be belt driven.
 - d. Fans to be equipped with lifting lugs.
 - e. Fan to be coated steel with a minimum of 4 mils of HiPro Polyester Resin
 - f. Fasteners to be 316 stainless steel.

2. Fan Housing And Outlet
 - a. Fan housing to be aerodynamically designed with high-efficiency inlet, engineered to reduce incoming air turbulence.
 - b. Fan housing shall be welded steel with a minimum of 4 mils of HiPro Polyester Resin. No uncoated metal fan parts will be allowed.
 - c. A high velocity conical discharge nozzle shall be supplied by the fan manufacturer and be designed to efficiently handle an outlet velocity of up to 6000 FPM. Discharge stack caps or hinged covers, impeding exhaust flow shall not be permitted.
 - d. Provide housing drain for removal of rain and condensation.
 - e. An access door shall be supplied in the housing allowing for impeller inspection or removal of impeller, shaft and bearings without removal of the fan housing.
 - f. Standard finish color to be ivory.

3. Fan Impeller
 - a. Fan impeller shall be centrifugal, backward inclined, with non-stall characteristics. The impeller shall be electronically balanced both statically and dynamically Grade G6.3 per AMCA Standard.
 - b. Fan impeller shall be manufactured of aluminum, fully welded and coated with a minimum of 4-6 mils of HiPro Polyester resin.

4. Fan Bypass Air Plenum
 - a. For constant volume systems, the fan shall be connected directly to the exhaust duct without the need of bypass damper.
 - b. For variable volume systems, a bypass air plenum shall be provided as shown on drawings. The plenum shall be equipped with a bypass air damper and intake air hood with birdscreen for introducing outside air at roof level upstream of the fan. The plenum shall be constructed of fully welded galvanized steel, and coated with 4-6 mils of HiPro Polyester resin, and mounted on roof curb as shown on the project drawings. Flexible connectors shall not be permitted.
 - c. Bypass air damper shall be opposed-blade design, and shall be fabricated of aluminum.

- d. A fan isolation damper fabricated of aluminum and coated with HiPro Polyester resin shall be provided as shown on the project documents.

5. Fan Motors And Drive

- a. Motors to be premium efficiency, standard NEMA frame, 1800 RPM, TEFC with a 1.15 service factor. A factory mounted NEMA 3R disconnect switch shall be provided for each fan. Motor maintenance shall be accomplished without fan impeller removal or requiring maintenance personnel to access the contaminated exhaust components.
- b. Fans submitted that use 900 RPM, 1200 RPM, or are C-Face motors, shall include one spare motor per fan system, in accordance with ANSI Z9.5, section 4.14.7.4, CRITICAL SERVICE SPARES.
- c. Drive belts and sheaves shall be sized for 150% of the motor horsepower, and shall be readily and easily accessible for service, if required.
- d. Fan shaft shall be 316 stainless steel.
- e. Fan shaft bearings shall be Air Handling Quality, ball or roller pillow block type and be sized for an L-10 life of no less than 100,000 hours. Bearings shall be fixed to the fan shaft using concentric mounting locking collars, which reduce vibration, increase service life, and improve serviceability. Bearings that use set screws shall not be allowed. Bearings shall have extended lube lines with Zerk fittings.

6.	Manufacturer:	Model/Series
	Greenheck	TCB-LE
	Strobic Air	Tri-Stack
	Twin City	TFE

2.08 FAN: CENTRIFUGAL INLINE - SQUARE CONSTRUCTION

- 1. Factory assembled with all components mounted on a reinforced steel stand.
- 2. Casing: heavy gauge steel, square design, rigidly reinforced and supported, seams permanently sealed airtight. Flanged outlet connection. Provide access doors on two sides for easy access. All components shall be enamel primed and finish painted with enamel.
- 3. Wheel: all aluminum centrifugal backwardly included blades welded or riveted to the side and hub plates. Matching inlet cone.
- 4. Shaft: hot rolled steel, ground, keyed to the wheel.
- 5. Bearings
 - a. Self-aligning, grease lubricated, split pillow block type.

6. Drive: adjustable v-belt, factory set. Drives shall be rated for 165% of rated horsepower.
7. Open drip-proof motor and drive enclosure.
8. Accessories:
 - a. Insulated housing
 - b. Integral disconnect switch
 - c. Companion flanges
 - d. Motorized Backdraft Damper
 - e. Motor cover
 - f. Variable speed controller
 - g. Inlet guards
 - h. Outlet guard
 - i. Inlet vane damper
9. Manufacturer: Model/Series:
Loren-Cook SQIB
Greenheck BSQ
PennBarry SX

2.09 FAN: CENTRIFUGAL - ROOF MOUNTED - ROUND DOME - ALUMINUM

1. Motor driven centrifugal fan unit built into removable all aluminum weather tight housing; belt drive, designed for roof curb mounting.
2. Fan motor - drip-proof, with disconnect switch. Mount motor driven on vibration isolators.
3. Screen air discharge with removable aluminum (.047") bird screen.
4. Mount fans on prefabricated, double wall aluminum acoustically lined base, with integral sound baffles, minimum 12 inches above the roof.
5. Provide anti-condensate coating or baked epoxy coating on housing.
6. Accessories
 - a. Unit mounted disconnect switch
 - b. Anti condensate coating
 - c. Motorized back draft damper
 - d. UL listing
 - e. Solid state speed controller

7.	Manufacturer:	Model/Series
	Acme Engineering Co.	PR, PN
	Greenheck Fan Corp.	G, GB
	Loren Cook	ACEB, ACED
	Penn Ventilator Co.	DOMEX

2.10 FAN: CENTRIFUGAL - ROOF MOUNTED - UPBLAST - KITCHEN

1. Roof exhaust fans shall be a vertical discharge type. Construction of fan housing shall be heavy gauge spun aluminum. The fan wheel and inlet cone shall be high performance, centrifugal blower.
2. The motor and drive housing shall be completely sealed from the exhausted air and fumes. A felt shaft seal shall be provided. Air for cooling the motor shall be taken into the motor chamber by means of air tubes from a location free of discharge contaminates.
3. The entire drive assembly and wheel, as a unit, shall be removable through the support structure without dismantling the fan housing in any way.
4. The wheel shall be directly connected to the motor shaft.
5. The entire drive assembly shall be mounted on rubber vibration isolators.
6. Fans shall be AMCA approved for sound and air performance.
7. Fans shall be U.L. and N.F.P.A. rated for kitchen exhaust.
8. Mount ventilator on prefabricated, double wall aluminum base, and minimum 12 inches above the roof.
9. Accessories:
 - Pre-fab roof curb (less acoustical baffles).
 - Extended base (fan bottom min. 18" above roof, fan discharge min. 40" above roof).
 - Bird screen.
 - Grease trough.
 - Manual starter.
 - Grease collection container
10. Manufacturer:

Acme Engineering Co.	PUB
Greenheck Fan Corp.	CUBE
Loren Cook	VCR
Penn Ventilator Co.	FUMEX

2.11 FAN: CENTRIFUGAL - CEILING CABINET

1. Centrifugal, with fan wheel direct connected to a 1075 RPM motor, mounted in an acoustically lined cabinet. Top horizontal discharge.
2. U.L. and AMCA rated.
3. Manufacturer: Model/Series:
Acme Engineering Co. MASTER-ETTE
Greenheck Fan Corp. SP, CSP
Loren Cook GEMINI
Penn Ventilator Co. ZEPHYR

2.12 AIR INTAKE / RELIEF HOOD: ROUND DOME - ALUMINUM

1. Gravity intake with all aluminum weathertight housing; designed for roof curb mounting.
2. Screen air inlet with removable aluminum (.047") bird screen.
3. Mount ventilator on prefabricated, double wall aluminum acoustically lined base, minimum 12 inches above the roof.
4. Anodize all visible aluminum components natural aluminum.
5. Manufacturer: Model/Series:
Greenheck Fan Corp. GRS
Loren Cook TR
Twin City

2.13 AIR INTAKE / RELIEF HOOD: LOW PROFILE - ALUMINUM

1. Gravity intake with all aluminum weathertight housing; designed for roof curb mounting.
2. Screen air inlet with removable aluminum (.047") bird screen.
3. Mount ventilator on prefabricated, double wall aluminum acoustically lined base, minimum 12 inches above the roof.
4. Anodize all visible aluminum components natural aluminum.

- | | | |
|----|-----------------------------|---------|
| 5. | Manufacturer: Model/Series: | |
| | Acme Engineering Co. | EV/EI |
| | Greenheck Fan Corp. | FHR/FHI |
| | Loren Cook | VR/VI |
| | Penn Ventilator Co. | AIRETTE |

2.14 VAV UNIT: LOW PRESSURE

1. Cabinet shall be constructed of zinc coated steel with 1" internal insulation. Insulation shall meet standards of specification section 230700.
2. Air volume damper shall be constructed of extruded aluminum components with nylon fitted bearings. Air leakage shall not exceed 2% at 1" W.G. inlet pressure.
3. Damper operator shall be factory mounted and compatible with space thermostats specified in specification section 230923. Units shall be of the pressure independent type capable of operating with inlet pressures between 1.0 and 3.0 inches of water.
4. Unit shall be factory tested prior to shipment.
5.

Manufacturer:	Model/Series:
Titus	DESV
Trane	VariTrane
Anemostat	EZT

2.15 VAV UNIT: LOW PRESSURE - HOT WATER REHEAT

1. Cabinet shall be constructed of zinc coated steel with 1" internal insulation. Insulation shall meet standards of specification section 230700.
2. Air volume damper shall be constructed of extruded aluminum components with nylon fitted bearings. Air leakage shall not exceed 2% at 1" W.G. inlet pressure.
3. Damper operator shall be factory mounted and compatible with space thermostats specified in specification section 230923. Units shall be of the pressure independent type capable of operating with inlet pressures between 1.0 and 3.0 inches of water.
4. Unit shall be factory tested prior to shipment.
5. Heating Coil

6. Seamless copper tubes with brazed copper return bends and without internal turbulence inducers. Aluminum plate or helical fins. Red brass headers each with drains and vents.
7. Flanged minimum 16 gauge galvanized steel casings with mounting holes.
8. Mount and arrange components to permit expansion without strain on tubes, headers or casing and with all guides and supports necessary to assure proper alignment and drainage.
9. Support - All units shall be independently suspended from the building structure. Provide auxiliary steel for hanging where required. Resting the units on ceiling structure will not be permitted.
10.

Manufacturer:	Model/Series:
Titus	DESV
Anemostat	EZT
Carrier	35E
Trane.	VariTrane

2.16 FAN COIL UNIT: CABINET - 4 PIPES

1. Vertical cabinet centrifugal type.
2. Cabinet: 18 gauge, nominal with 16 gauge front panels; channel formed edges around entire perimeter.
3. Chassis: Minimum 18 gauge galvanized steel, reinforced with flanged edges lined with 1/2" thick, 1 lb. density neoprene faced fiberglass. Galvanized steel drain pan with insulating liner.
4. Fan: Double inlet, double width, forward curved, galvanized steel wheel and scroll. Fan, motor and drain pan assembly shall be removable as a unit.
5. Coils:
 - a. Cooling/heating coil: 5/8" O.D. seamless copper tubes, with aluminum fins, mechanically bonded.
 - b. Test coils at the factory for maximum working pressures of up to 300 PSI.
6. Motors: Multispeed permanent split capacitor type directly connected to an extension of fan shaft. Maximum fan motor speed 1100 RPM. Provide integral thermal overload protection. Unit mounted fan speed switch. Provide special motors for all units scheduled with external static pressures of 0.10 inches or greater. Motors shall be capable of delivering scheduled CFM at static pressures

indicated.

7. Filter: 1" disposable woven glass.
8. Accessories:
 - a. Two-pipe valve package with automatic summer/winter changeover (Trane H-37).
 - b. Four pipe valve package, including two way control valves for hot and chilled water, two stop valves for each service and an air vent on each service. Provide three way chilled water control valves where indicated on plans or in equipment schedules. Control valves shall be provided in conformance with Specification Section 230923
 - c. Tamper proof panel
 - d. Unit sub-base.
 - e. Extended motor oiler lines.
9. Manufacturer: Model/Series:

Trane	Unitrane
Carrier	42V
International	FXY

2.17 DUCTED TYPE FAN COIL FOR CONCEALED OR EXPOSED MOUNTING

1. Factory assembled unit including fans, cooling/heating coil, filter, fan, multi-speed motor, drain pan, wiring and controls. Units shall be UL listed.
2. Cabinet - galvanized steel with 1/2" of faced fiberglass insulation. Provide collars for supply and return duct connections. Horizontal units shall have a removable bottom access grille.
3. Fan - centrifugal, forward curved, double width. Wheel - keyed to steel shaft. All components exposed to the air stream shall be constructed of galvanized steel.
4. Motors - High efficiency type, three speed permanent split capacitor type with sleeve bearings and an oil reservoir.
5. Chilled/Hot Water coil - 1/2" O.D. copper tubes with aluminum fins arranged to handle 100% of the air quantity without bypass. No internal turbulence inducers. Coils shall be factory tested at 250 PSI. Coil headers of C.I. or copper. Coil casing of galvanized steel. Provide a manual air vent for each coil section. Provide an overflow drain pan connection.
6. Accessories.
 - a. Magnehelic 2002AF filter gauge by Dwyer, Inc.
 - b. Extended grease fittings.
 - c. Remote three speed, four position switch for remote mounting
 - d. Drain pan extension

- e. Control valve package.
- f. Isolation and balancing valve assembly.
- g. 24 volt thermostat for wall mounting.

7.	Manufacturer:	Model/Series:
	Carrier Corp.	42D series
	Trane	Unitrane
	International	CXB/CPY

2.18 UNIT HEATER: HOT WATER/STEAM

- 1. Horizontal mounted with propeller fan direct connected to electric motor.
- 2. Coil: Copper tubes with aluminum fins mechanically bonded to the tubes.
- 3. Casing: Minimum 18 gauge steel with steel fan guard and horizontal deflection or outlet cone louvers. Finish in baked enamel.
- 4. Motor: Permanent split capacitor with built-in thermal overload protection.
- 5. Manufacturer: Model/Series:
 - Modine HS
 - Sterling HS
 - Trane UHS

2.19 CABINET UNIT HEATER: HOT WATER

- 1. Vertical or horizontal centrifugal cabinet type.
- 2. Cabinet: 16 gauge removable front with 18 gauge side and back panels. Bonderize metal surfaces, and apply one coat of baked on primer. Finish with baked on enamel. Finish color to match samples to be provided by the Architect.
- 3. Fan: Forward curved centrifugal type, constructed of fiberglass reinforced thermoplastic.
- 4. Coil: 5/8" O.D. copper tubes with mechanically bonded aluminum fins.
- 5. Motor: Multispeed permanent split capacity type, connected to an extension of the fan shaft.
- 6. Filter: 1" disposable woven glass.
- 7. Manufacturer: Model/Series
 - Trane Force-Flo
 - McQuay CHF
 - Sterling W/RW

2.20 AIR DOORS

1. General: factory-assembled units of sufficient structural strength to be supported from ends without intermediate support. Ship units completely assembled.
2. Cabinet:
 - a. Material: Minimum 16-gage aluminized steel with gray colored powder coat finish with mill aluminum inlet screen, all welded construction. Tamper-resistant construction; parts cannot be disassembled without special tool provided by manufacturer.
 - b. Mounting: Provide for top of wall mounting.
 - c. Removable top and bottom panel for access.
3. Motors: 1/2-HP, three (3) phase, 1 speed, double extended shafts with sealed bearings.
4. Fans: Balanced forward curved centrifugal type, double inlet, double width design, mounted in matched fan housings with aerodynamically formed air inlet venturis. Manufacture wheels and housings from galvanized steel.
5. Discharge Nozzles:
 - a. Provide uniform velocity across width of air door.
 - b. Aperture: 3-1/2 inches slot by width of air door.
6. Vanes: 1-1/2 inches minimum height; constructed of airfoil-shaped aluminum extrusions; adjustable plus or minus 20 degrees to deflect airflow.
7. Location: Front
8. Screen: Perforated pattern [mill aluminum] [stainless steel] with border.
9. Air Inlet Filter: Flat-faced recleanable aluminum with screen.
10. Heating Elements
 - a. Glycol Hot Water Coil: Certified in accordance with ARI 410; constructed from 5/8-inch (15.8 mm) outside diameter copper tube with aluminum fins.
 - b. Characteristics: Design to operate at maximum 250-psig (1720-kPa) and 300 degrees F (149 degrees C) hot water.
 - c. Leak-test under water at 350-psig (2410-kPa) dry nitrogen.
 - d. Factory mount coil on air intake and protect with perforated metal screen.

11. Controls

a. Control Panel:

- 1) UL listed, industrial type, pre-wired, with components consisting of motor starter, terminal strip, motor overloads, and control transformer with 120 volt fused secondary.
- 2) Single power supply.
- 3) Enclosure: Oil-tight and dust-tight NEMA Type 4 enclosure with neoprene door gasket.
- 4) Mounting: Unit mounted.
- 5) Time Delay Relay: Adjustable in field from 0.1 second to 10 hour delay.
- 6) Disconnect Switch: Provide units with non-fused toggle disconnects based on number of power supplies required.
- 7) HAND-OFF-AUTOMATIC Switch: Switch allows manual on-off operation or operation controlled by automatic door switch that activates unit when door opens and deactivates unit when door closes.
- 8) START-STOP Switch: Provide START-STOP push button operation.
- 9) ON-OFF Switch: Allows manual on-off operation.

12. Manufacturer:

Berner
Mars Air Systems
Marley

2.21 ADJUSTABLE V-BELT DRIVES

1. For all belt-driven equipment: A complete matched set to transmit the power to the driven equipment; not less than two belts per drive.
2. Sheaves: Adjustable plus or minus 10%. When motor is 15 HP or over, use, companion type sheaves.
3. Belts: Reinforced rubber or neoprene.
4. Service Rating: Not less than 200% of the maximum estimated load; greater if specified for particular apparatus.
5. Minimum efficiency: 95%.
6. Manufacturer:
Browning Mfg. Co.
T.B. Wood's Sons Co.
Maska

2.22 MACHINERY GUARDS

1. Guard all visible moving parts of machinery, including fan belt drives, by barriers constructed of properly supported and easily removed 1-1/4" x 1-1/4" x 1/8" galvanized angle iron frames and 3/4" No. 16 galvanized expanded metal mesh. Round and finish all guard edges.
2. Provide openings equal to twice the diameter of the shaft for the insertion of a tachometer in all machinery guards covering the ends of motor or equipment to allow adjustment of belt tension.

2.23 FILTER GAUGES

1. At each filter bank, provide a mounted 4-1/2" diameter dial gauge with brass valved connection tubing to brass static pressure sensing tips upstream and downstream of the filter bank.
2. Scale: Clean filter drop at mid scale
Graduated in 0.2" W.G. increments.
3. Manufacturer: Model/Series:
F.W. Dwyer Mfg. Co. Magnehelic Series 2000 or approved equal

2.24 AUTOMOBILE EXHAUST SPRING RETRACTABLE HOSE REEL

1. The vehicle exhaust extraction system shall consist of an Automatic Spring Hose Reel, designed for manual extension and spring return of high temperature flexible exhaust hose. System shall also include a 6" diameter, 25'-0" length of high temperature exhaust hose and tailpipe nozzle.
2. The hose reel side plate mounting support frame shall be constructed of 11 gauge cold rolled steel.
3. Exhaust hose shall be double ply with an inner liner ply of woven fiberglass coated silicone rubber. A helically wound spring steel wire shall be imbedded between the inner liner ply and an exterior ply of woven Nomex coated with silicone rubber. The assembly shall be double wound with a treated Nomex cord and heat vulcanized to provide a greater strength and serviceability. The hose shall be rated for 1250 deg F for intermittent use, an interior temperature of 1000 deg F and a 600 deg F continuous duty baking test.
4. The side plates shall be drawn securely together and retained by heavy gauge "J" channel steel support braces. These support braces keep the side plates square and solid.

5. The hose reel drum shall be constructed of 16 gauge cold rolled steel. The drum shall be formed and rolled to an 18" diameter and strengthened by four inner support bars. These bars are secured to the drum end flanges and pull the drum tightly against the end flange. The drum end flanges shall be constructed of 16 gauge cold rolled steel. The end flange outer edge shall be rolled to provide strength and rigidity. Each end flange shall have a center pressed 18" diameter groove. This groove allows the reel drum and end flange to mate so the drum's inner support bars draw the end flange securely to the drum.
6. The hose reel shall have a hose to drum connection fitting allowing for use of either 4", 5", 6", or 8" hose. The connection fitting supports an inner 6" or 8" diameter tube that completes the connection from the connection of 6" or 8" diameter discharge duct.
7. The hose reel drum shall also be supplied with a hose tracking bar to guide the hose during the recoiling function.
8. The hose reel function shall consist of a spring cassette housing containing a high carbon drive spring. The activation of the manual extension and spring return is by a Lock and Latch feature. The necessary length of hose desired can be locked in place and the hose is automatically retracted after use.
9. The hose reel functions of uncoiling and recoiling of the hose shall be by direct pulling on the extraction hose. The reel shall have an adjustable hose stop to set the hose at the desired recoiling height. This stop shall be mounted to the extraction hose.
10. The 6" diameter nozzle shall be rubber coated metal with a handle, locking hand damper, metal screen, sleeve and Vise Grip type clamping system.
11. Manufacturer shall be Monoxivent, Car-Mon, Nederman or approved equal.

2.25 FUME EXTRACTION SYSTEM

1. The fume extractor system shall consist of a single exhaust fan, a ducted exhaust network, and individual bench top fume extractor arms.
2. The fume extractor arm shall have a 360° swivel elbow, support flange, jointed elbows of polypropylene with glass fiber reinforcement and knurled adjusting knobs, internal spring support, pre-set joints with wear discs that can be adjusted if required, thin-walled anodized aluminum arm sections (anodization 10 microns), mini polycarbonate hood at the end of the arm, quiet thermoplastic elastomer damper with positive seal, anodized aluminum damper handle, external rings of polypropylene with glass fiber reinforcements, axial locking rings of polypropylene

with glass fiber reinforcements, stainless steel threaded shaft inside of joints, stainless steel internal spring, swivel bearings of polypropylene with glass fiber reinforcements, aluminum swivel, and aluminum bearings.

3. The exhaust fan shall be a N-Series Fan, centrifugal low pressure blower type with a 16 blade modified radial tip impeller and a direct drive motor.
4. Motors shall be, TEFC with 460V/3ph/60Hz electrics. Blower wheel shall be direct drive operating at 3450 rpm.
5. Blower housing shall be 14 gauge. A polyester epoxy lacquered galvanized sheet metal housing shall provide round outlet for easy flange, pipe or hose connection. Blower shall have dynamically balanced steel plate impeller.
6. All motors shall be continuous duty type and exceed IP54 protection standards.
7.

Manufacturer:	Model:
Nederman	BT2 plus N 40 Series fan
Plymo-Vent	KUA
Vent-A-Kiln	Place-A-Vent

2.26 DUST COLLECTOR

1. Dust collector shall be suitable for wood working dust control. It shall be a freestanding weatherproof self-contained unit, mounted on structural frame of heavy gauge steel construction, with fan, filter cartridges, and prewired motors, timer, and starter.
2. Fan shall be rated at 20,054 CFM/10" TSP, and shall be backward inclined blades, TEFC motor, 60 HP, 1750 RPM, 460V/60 Hz/3 phase. Fan wheel shall be non-sparking. Under normal operation the fan will be operating at 18,000 cfm.
3. Filter section shall have hinged access door(s) for walk-in to filter section. Filters shall be Polyester bags, 8" dia. (washable) by 7' long, and shall have filter shaker rack and two TEFC 1 HP motors with gear reducers. Shaker motor drive(s) shall be located inside filter section on clean air side. Sprinkler head and connection shall be provided in filter cabinet. An inlet backdraft damper shall be provided.
4. Hopper below filter section shall contain minimum 1,000 cubic feet of storage. Unit shall have manually operated discharge slide gate, 42" x 42", for truck waste removal.

5. Unit shall be constructed with a structural steel frame, complete with all required platforms and railings, OSHA guards and a safety ladder. Unit shall be prime and finish painted at the factory.
6. Unit shall be provided with pre-wired control panel, mounted in NEMA 4 enclosure. All wiring shall be terminated on terminal blocks, with matching terminal blocks and knockouts for external field-provided power and control wiring.
7. ***Provide abort damper at system outlet with supports, foundation, service platform, ladder and OSHA cage.***
8. ***Provide fire damper at outlet of dust collector.***
9. Manufacturer: Model/Series:
Kraemer Type A, Arrangement 1 or acceptable equivalent.
AAF Millennium
Torit Baghouse

2.27 SOUND ATTENUATORS

1. Outer casing of 22 gauge stainless steel and to shall be continuously welded.. Lock formed seams, mastic filled. 26 gauge perforated stainless steel interior partitions.
2. Filler material: No media
3. Seal joints airtight in the field. Casing shall not fail structurally when subject to 8.0 inches internal static.
4. Provide mating flanges for connection to ductwork.
5. Submit certification of acoustical performance from an independent testing laboratory.
6. Performance: Refer to plans for schedule of attenuator characteristics.
7. Manufacturer:
Industrial Acoustics
Aerosonics
Vibro-Acoustics

2.28 AIR PURIFIERS (COSMETOLOGY)

1. Cabinet: 18 gauge steel, polyurethane powder painted outside and inside.

2. Blower: High performance, UL certified for US and Canada
3. Electrical: Remote speed control with 7'-0" long cord and 7'-0" long power cord with plug.
4. Noise Level: 58-60 dBA @ 6'-0"
59-61 dBA @ 12'-0"
5. Filters
 - a. Prefilter: Multi-Density Polyester Panel
 - b. Primary Filter: High efficiency rigid cell
 - c. Final Filter: Polyester panel impregnated with activated charcoal
 - d. Neutralizer: Non-woven fiber element impregnated with an odor neutralizing compound.
6. Provide low profile caster base.
7. Manufacturer: Air Impurities Removal Systems, Inc or approved equal.

2.29 **SPARK ARRESTANCE SYSTEM (DUST COLLECTION SYSTEM)**

1. ***Provide each dust collection system with a spark detection & extinguishment system to National Fire Protection Association standards (NFPA), 69, 664, and 72 guidelines. The system shall be a single zone control system, as manufactured by Hansentek or approved equal. All components shall be Factory Mutual (FM) approved.***
2. ***The system shall comprise of the following components:***
 - a. ***The AN100 programmable microprocessor panel shall include programmable shutdown, built-in automatic and manual detector sensitivity checking. The system shall provide supervision on all input and output circuits. Fan shutdown relay shall be included, as well as alarm and trouble relays. The system shall have a battery backup power supply & Model #910 24 VDC alarm horn.***
 - b. ***Two Model #100-1W addressable infrared direct optic spark detectors with built-in test light for calibrated through the lens sensitivity checking & quick release brackets.***
 - c. ***Model #900-1S Spray assembly with spring-loaded, chrome plated nozzle, 24VDC solenoid, water strainer, mounting flange and gasket.***
3. ***The spark detection & extinguishing system shall be installed indoors and located on and penetrating into a straight horizontal section of the main duct, in the area between the first branch and the dust collector. Based on an air &***

dust velocity of 4000 fpm in the main duct, the sensor (spark detector) to solenoid valve (spray nozzle) distance (SVD) must be a minimum of 20'. Allow for additional straight duct 1-1/2 duct diameter before and after the detectors & spray nozzle. Flow rate shall be a minimum of 19 GPM at 50 psi. Coordinate installation with sheet metal, plumbing and electrical contractor.

4. *System must be installed in accordance with the manufacturer's installation requirements, in the installation manual and tested before placing the system in operation.*

PART 3 - EXECUTION

3.01 GENERAL

1. Install equipment in conformance with manufacturer's recommendations.
2. Provide adequate service access and clearances around roof top equipment as per 2003 IMC section 306.5.

3.02 WARRANTY

1. The contractor shall provide to the owner an equipment warranty of no less than 18 months. The warranty period shall begin at the time of substantial compliance of a given phase as provided by the commissioning agent. The contractor shall refer to the phasing documents for installation and start of equipment.
2. The contractor shall furnish and install parts and labor as required for maintenance during the Warranty period.

3.03 MAINTENANCE

1. The contractor shall maintain the air handling equipment during the warranty period. Air handling equipment shall include items listed in this specification and, vav and fan powered units, cabinet unit heaters, exhaust fans etc. The maintenance shall be in accordance with manufacturers recommendations. The contractor shall furnish and install parts and labor during the warranty period at no additional cost to the owner. The contractor shall change the filters every 60 days.
2. The contractor shall maintain the air handling equipment until the project completes the last phase of construction. Refer to the phasing documents for time durations. The maintenance shall be in accordance with manufacturers recommendations. The contractor shall furnish and install the required maintenance of the equipment at no additional cost to the owner.

3. The maintenance shall include but not be limited to monthly greasing, equipment checks, 60 day filter changes (filters as specified), motor belts, coil cleaning every 6 months, phasing test for the addition of new equipment and piping, and cleaning.

END OF SECTION

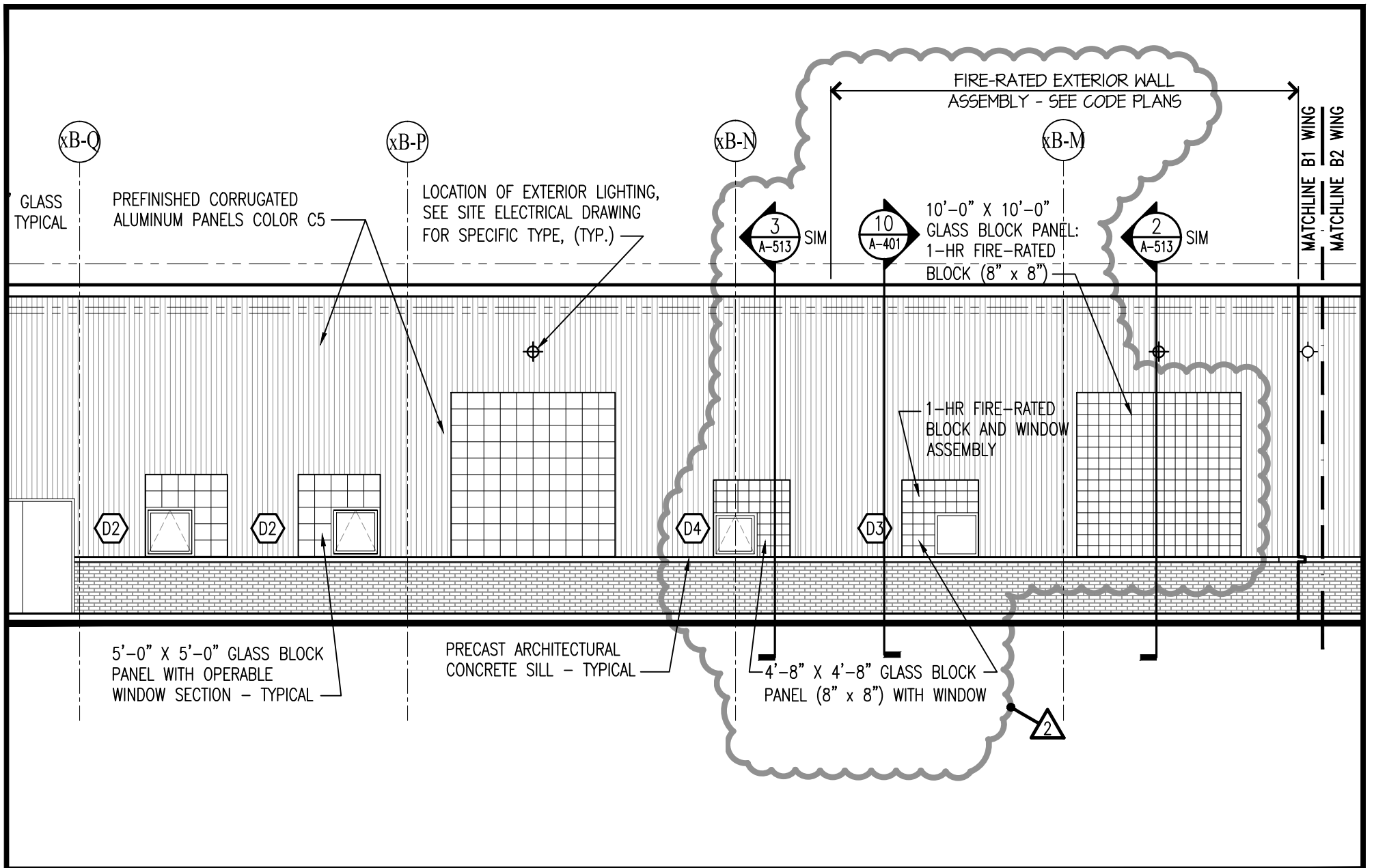

ANTINOZZI ASSOCIATES
ARCHITECTURE & INTERIORS

ELI WHITNEY CTHSS
ADDITIONS AND RENOVATIONS
STATE PROJECT NUMBER: BI-RT-837
71 JONES ROAD
HAMDEN, CONNECTICUT

DRAWING TITLE:
REVISED PARTIAL "B" WING - WEST ELEVATION (PARTIAL)

DRAWING NO.

SKA-04

REF. DET.: 2A/A-303 (PART OF ADDENDUM - 02)

SCALE: 1/8" = 1'-0"	DRAWN BY: JDS	REVIEWED BY: DCF	DATE: 24 JULY 2012	JOB NUMBER: 11025
------------------------	------------------	---------------------	-----------------------	----------------------

ALL SCHEDULE - (NEW OPENINGS)

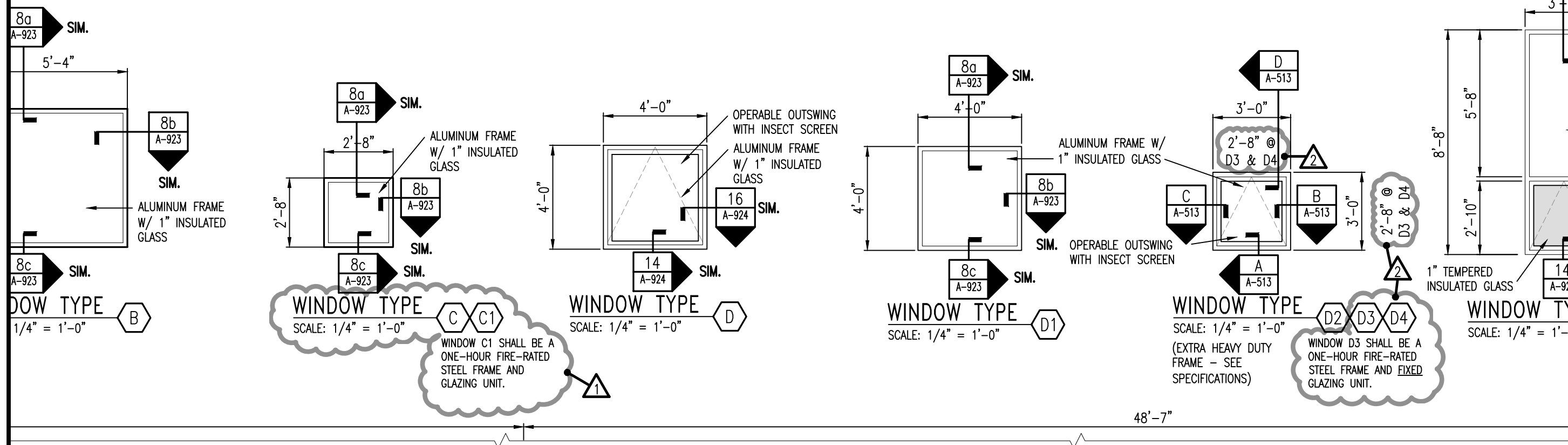

<p>ANTINOZZI ASSOCIATES ARCHITECTURE & INTERIORS</p>	<p>ELI WHITNEY CTHSS ADDITIONS AND RENOVATIONS STATE PROJECT NUMBER: BI-RT-837 71 JONES ROAD HAMDEN, CONNECTICUT</p>		<p>REVISED WINDOW TYPES (PARTIAL)</p>	<p>SKA-08</p>
	<p>DATE: 24 JULY 2012</p>	<p>REVIEWED BY: DCF</p>	<p>DRAWN BY: JDS</p>	<p>JOB NUMBER: 11025</p>

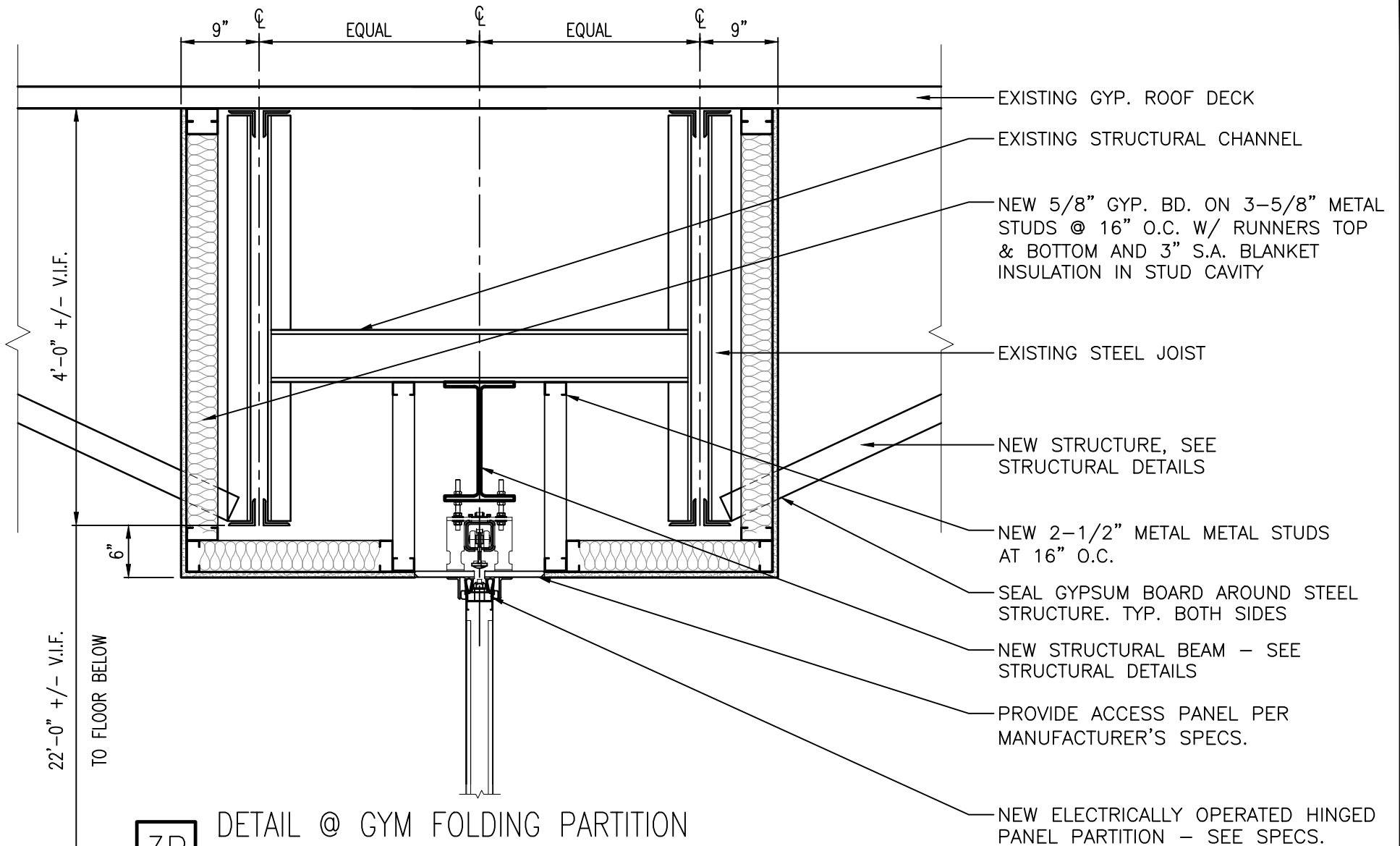

3B

DETAIL @ GYM FOLDING PARTITION

SCALE: 3/4" = 1'-0"



ANTINOZZI ASSOCIATES
ARCHITECTURE & INTERIORS

ELI WHITNEY CTHSS
ADDITIONS AND RENOVATIONS
STATE PROJECT NUMBER: BI-RT-837
71 JONES ROAD
HAMDEN, CONNECTICUT

DRAWING TITLE:
DETAIL @ GYM FOLDING WALL PARTITION

DRAWING NO.

SKA-10

REF. DWG.: NEW DETAIL ON A-201.1 (PART OF ADDENDUM - 02)

SCALE:	DRAWN BY:	REVIEWED BY:	DATE:	JOB NUMBER:
AS NOTED	FJR	DCF	24 JULY 2012	11025